

TRAMPOLINE

USER MANUAL



TRAMPOLINE WITH SAFETY NET

INTRODUCTION

Before you begin to use this trampoline. You must read all the information in this manual. Just like any other type of physical recreational activities, participants can be injured. To reduce the risk of injury be sure to follow the appropriate safety rules and tips.

- Misuse and abuse of this trampoline is dangerous and can cause serious injury!
- Trampolines are rebounding devices which propel the performer to unaccustomed heights through a variety of movements. So always use caution when playing on a trampoline.
- Always inspect the trampoline before each use.
- Proper assembly, care and maintenance of product, safety tips, warnings, and proper techniques in jumping and bouncing are all included in this manual. All users and supervisors must read and familiarize themselves with these instructions. Anybody who chooses to use this trampoline must be aware of their own limitations in regards to performing various jumps and bounces with this trampoline.

Initially, you should get accustomed to the feel and bounce of the trampoline. The focus must be on your body position and you should practice each fundamental bounce until you can do each skill with bounce before moving on to more difficult and advanced bounces. Do not bounce recklessly on the trampoline, emphasis must be made on good control and the mastering of various bounce techniques

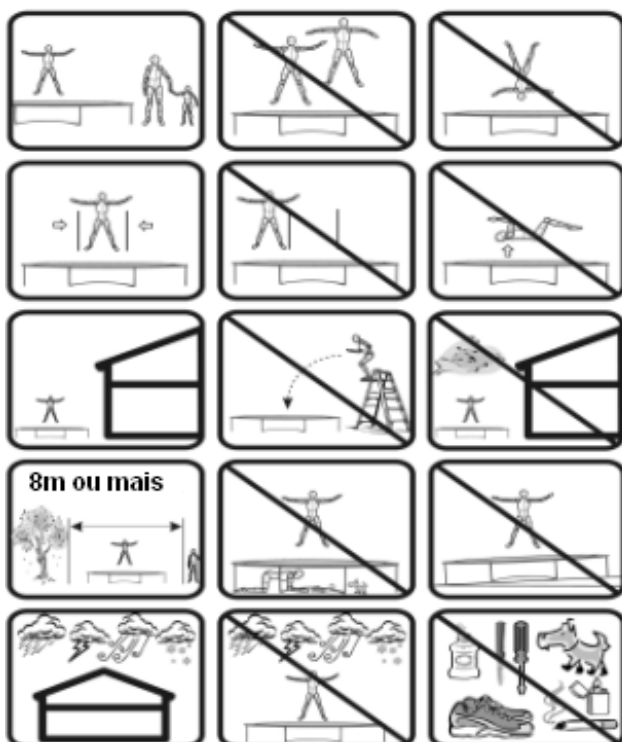

No more than one person is allowed on the trampoline! Multiple jumpers increase the risk of injury resulting from mid-air collisions.



Do not perform somersaults (flops) as this will increase the chances of landing on your head or neck. Paralysis or even death can result

TRAMPOLINE GUIDELINES

1. GENERAL INSTRUCTIONS

1.1 PURPOSE

- The product is intended for home/domestic use only and is not suitable for professional or medical uses.
- The maximum weight is 150kg. Overloading the trampoline above the recommended user weight will cause damage to the trampoline which is not covered by the warranty

1.2 DANGER FOR CHILDREN

- Do not let unsupervised children near this product. Carry out the necessary safety precautions and supervise all trampoline activities. Be aware that the packaging material is not suitable for children. There is a danger of suffocation!
- Trampolines over 51cm (20inches) in height are not recommended for children under 6 years of age. Children do not recognize potential dangers from this product. Keep children away from this product, it is not a toy. The product has to be stored out of reach of children and pets.

1.3 ATTENTION – PRODUCT DAMAGES

- Do not alter the product. Only use original spare parts. Repairs should only be carried out by qualified technicians. Improper repairs can compromise the safety of your trampoline. Use this product only as described in this manual
- Protect the product against humidity and high temperatures.

1.4 ADDITIONAL TIPS

- For additional stability you can place sand bags on the trampoline legs. This will prevent the trampoline from tipping over in the event of any sideways force.
- Do not use during pregnancy.
- Do not use when suffering from high blood pressure.
- Jump with bare feet. Do not wear shoe, this will damage the jumping mat which is not covered by the warranty.
- No smoking
- Do not put cigarettes, pets, sharp objects, or any other foreign objects, or any other foreign objects on the trampolines.
- Do not use the trampoline while under the influence of alcohol or drugs.
- Do not sit or lean on cover pads as it needs to be flexible so it can move with the jumping mat. Please do not allow small children to pull themselves up the trampoline by using the cover pads. Tears in stitching caused by obstructing frame pads are not covered by warranty.
- Place trampoline on level ground. Preferably on grass. Locating the trampoline on hard surface will add stress to the frame and overtime cause damage which is not

covered by the warranty. Placing the trampoline on an uneven surface may result in the trampoline tipping over.

- Do not expose the trampoline to direct contact with open flames.
- Secure the trampoline against unauthorized use.
- Do not use if trampoline is wet.
- Trampoline should be tied down with anchors during windy conditions or dismantled and stored away.

WARNING

1. Please ensure that the safety enclosure net zipper is 100% closed and all three entrance hooks are re-hooked before jumping.
2. Do not intentionally jump into the safety net, it is only designed to stop persons from falling off the trampoline. Intentional jumping into the safety net may cause the trampoline to tip over, or may damage your net. Abuse of the safety net is considered negligent use which is not covered by the warranty, please refer to the disclaimer.









2. SAFETY INSTRUCTIONS FOR TRAMPOLINES

- All users of the trampoline need a supervisor regardless of the age and the experience of the user.
- The safety instructions of the trampoline should always be considered and obeyed.
- Somersaults must be avoided. Incorrect landings on the trampoline can lead to injuries, particularly to the back, neck or head. Injuries may include paralysis. Or even death.
- Only one person should use the trampoline at a time. Multiple users on the trampoline will increase the risk of collision.
- The trampoline has to be examined for damaged, wearing or defective part before each usage, as it can impair the overall safety of the trampoline. The damaged, worn or defective parts should be replaced immediately. In the meantime the trampoline must be restricted from use.
- No clothes with hooks or parts may be worn when jumping on the trampoline, in order to avoid hooks getting caught.
- The trampoline must be set up only on a flat ground and non-slippery surfaces.
- Strong wind can blow the trampoline away. If strong winds are predicted the trampoline must be moved to a protected place, and taken apart. Or fastened to the ground with anchors and tie downs. At least three anchors are necessary. It is not enough to anchor the pennants in the ground since they can tear out of the patch cords.
- Try to avoid moving the assembled trampoline, because it could bend during transportation. Should it be necessary to move the trampoline, please consider the following: at least four people must be evenly spaced around the frame to lift the trampoline off the ground. The trampoline must be carried horizontally, and if the frame

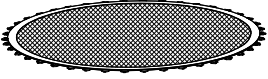
shifts position use four people to draw the trampoline in shape.

- Trampolines are jumping devices, enabling the user to jump to unusual heights as well as into a multiplicity of body movements. Jumping into the trampoline, hitting the frame, cover pads or incorrect landing on the trampoline can lead to injury.
- Users should be familiar with the user manual. This manual contains assembly instructions... selected precautionary measures as well as recommendations for servicing and maintenance of the trampoline in order to ensure a secured and fun use of the trampoline.
- It is the responsibility of the owner to guarantee that all users of the trampoline are informed to stay a safe distance away from trampoline as a safety precaution.
- Never use it near water and keep sufficient space around it as a safety precaution.
- Beware of moving parts which could catch your arms and legs?
- Do not stick any foreign objects in to the trampoline,
- Do not allow anyone or any object to go under the trampoline while someone is jumping on the mat. The jumping mat is flexible and downwards force created by someone jumping can cause serious injury to a person.
- Implement all safety rules and make yourself familiar with the information in the user manual
- The trampoline can only be used, if the jumping mat is clean and dry. Worn or damaged jumping mats should immediately be replaced.
- Keep all foreign objects away from trampoline.
- Avoid unauthorized and unsupervised use of the trampoline.
- Do not use the trampoline under influence of alcohol or drugs (incl. medicines)
- Learn the fundamental jumping techniques thoroughly before trying difficult jumps. For more information see section on fundamental bounce techniques in owner's manual.
- Climb on the trampoline. Do not jump on it directly. Do not use the trampoline as a jumping board for other articles. For more information, see section-accident categories: mounting and dismounting
- For further information or exercise information consult a trained trampoline teacher.

TRAMPOLINE PARTS LIST

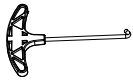
ITEM	Image	MODEL	6'-3	8'-3	10'-3	10'-4	12'-4	12'-5	13'-4	13'-6	14'-4	14'-6	15'-5	16'-6
A		Top Rail	6	6	6	8	8	10	8	12	8	12	10	12
B		Cover Pads	1	1	1	1	1	1	1	1	1	1	1	1
C		Jumping Mat	1	1	1	1	1	1	1	1	1	1	1	1
D		Spring	36	42	54	64	72	70	80	84	80	84	90	108
E		Leg Extension	6	6	6	8	8	10	8	12	8	12	10	12
F		Leg Base	3	3	3	4	4	5	4	6	4	6	5	6
G		Screws	12	12	12	16	16	20	16	24	16	24	20	24
H		Washer	12	12	12	16	16	20	16	24	16	24	20	24
I		Spring Fixing Tool	1	1	1	1	1	1	1	1	1	1	1	1

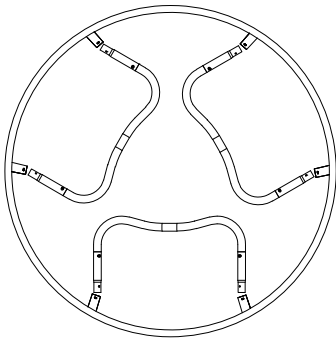

6FT-3, 8FT-3, 10FT-3
Trampoline (3 legs)

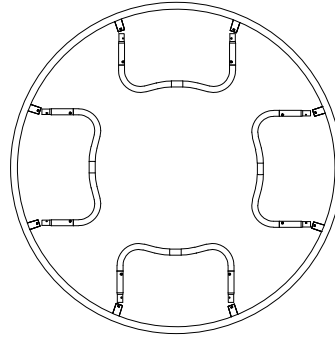

10FT-4, 12FT-4, 13FT-4, 14FT-4,
Trampoline (4 legs)

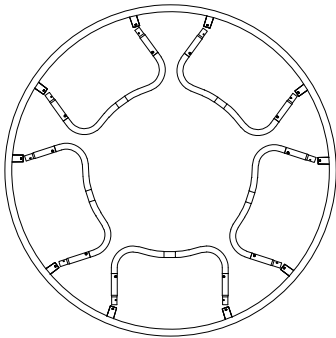

12FT-5, 12FT-5,
Trampoline (5legs)

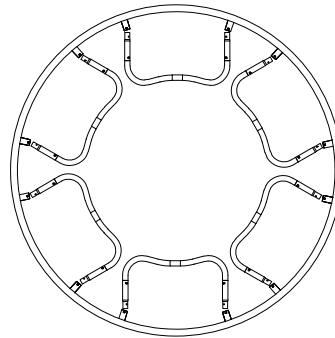

13FT-6, 14FT-6, 16FT-6,
Trampoline (6legs)

TRAMPOLINE ASSEMBLY

STEP 1

Frame Layout

Lay out the trampoline parts on the ground so that you start to form a circle with the top rail sections. Make sure to keep all the tubes in the same direction all around the trampoline frame.

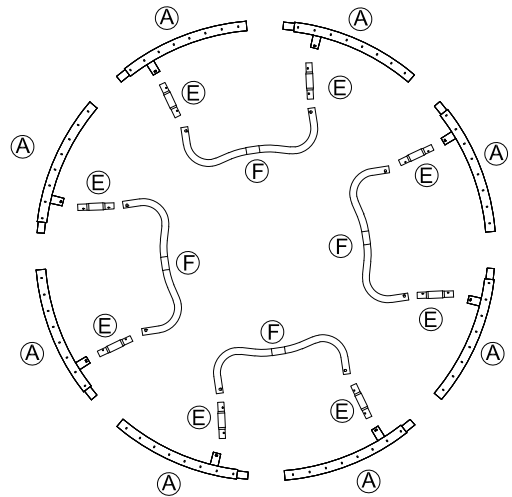

STEP 2

Assemble The Legs

Assemble each of the Leg base to the Leg Extension. Attach the leg extensions to the leg base and tightly secure together with the screws. Repeat this step for all legs.

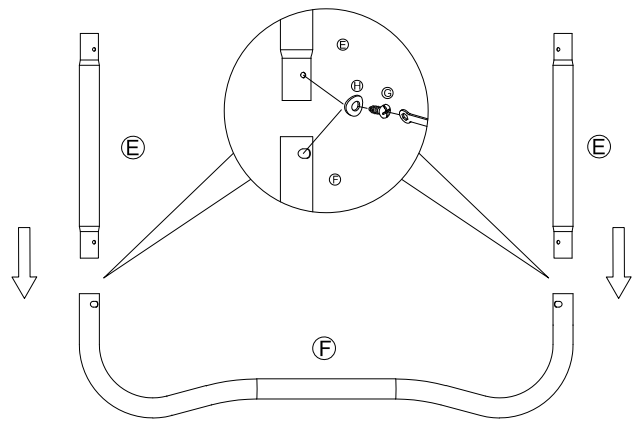

STEP 3

Assemble The Top Rail Tubes

Connect top rail tubes together one by one until you form a large circle. Joining the last bar may require two or more adults in good physical condition. With a second person holding the opposite end, bring both sides of circle together and have them secured. If your frame does not seem sturdy this should not worry you, for the trampoline mat will tighten it up.

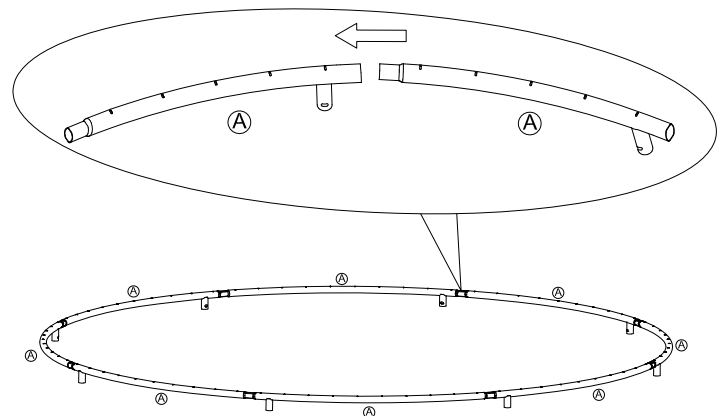

STEP 4

Connect The Legs Bases To The Top Rail Circle.

Attach the leg supports you assembled in step 2 to the top rails like the picture shown. Repeat this step until you have the full frame standing. Tightly secure the leg extension to the top rail frame with screws.

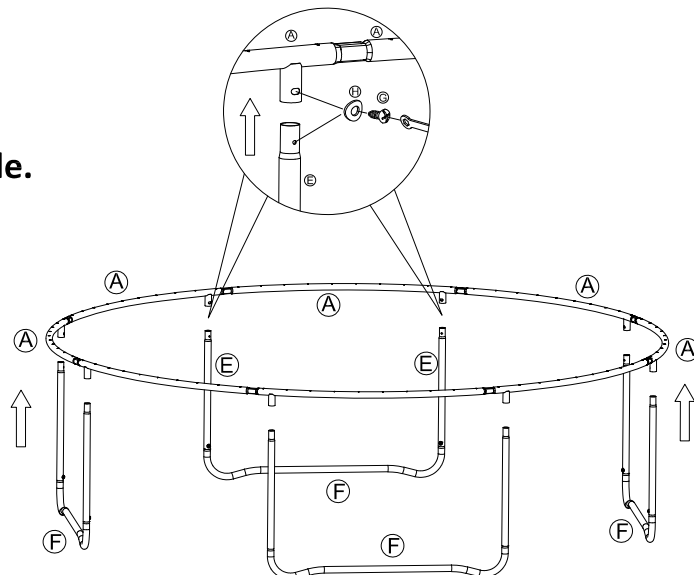

STEP 5

Jumping Mat Assembly

Warning: Be careful where you place your hands during spring assembly as connector points can pinch!

Lay out the Jumping Mat inside the frame.

1. First connect the 4 springs 1/4 circle apart from each other

2. Connect all middle springs as figure

4. Complete the rest of the springs

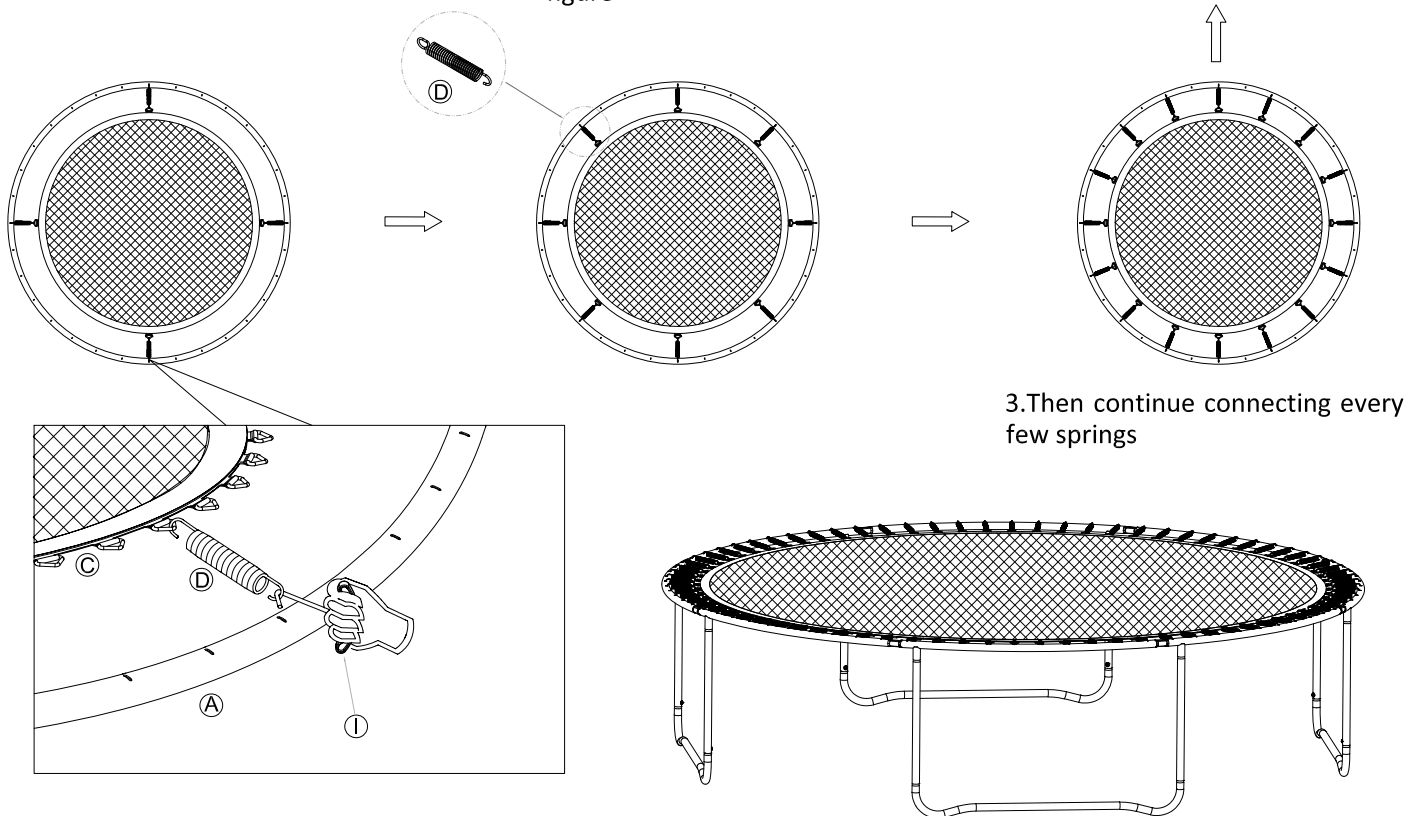

How To Use The Spring Fixing Tool

Step I: Hook the more rounded end of the spring onto the Jumping mat's triangular rings.

Step II: Extend the spring fixing tool and link it up with the other end of the spring. Pull the tool in the direction of the trampoline frame until the spring head is lined up with the hole in the trampoline frame. Slide the spring end into the hole as you remove the tool.

STEP 6 Cover Pads Assembly

Lay out the safety pad around the outer edge covering all the springs as shown on right.

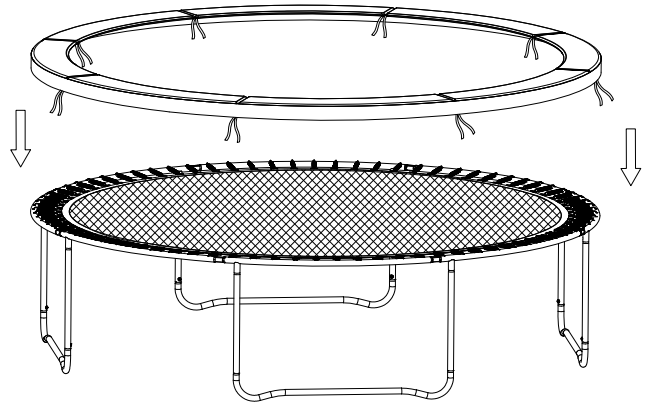



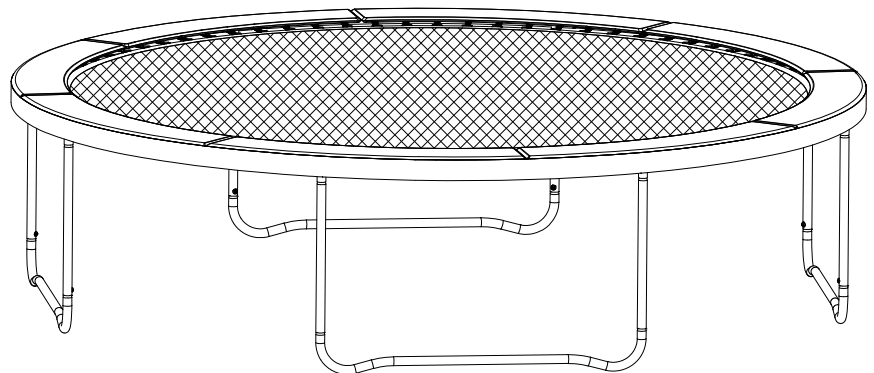
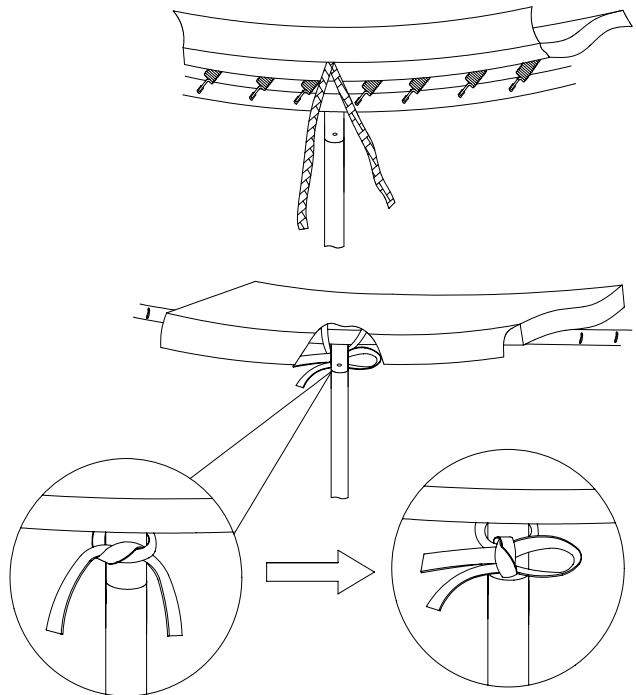

The safety pad has a few sets of straps all around the pad. Attach the straps to the V-rings of the mat or frame tube. Refer to the figure at the side to see how to attach it correctly.

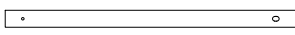
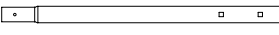

This is how your trampoline should look now.

ENCLOSURE PARTS LIST

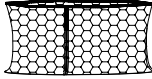
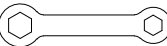
ITEM	Image	MODEL	6'-3	8'-3	10'-3	10'-4	12'-4	12'-5	13'-4	13'-6	14'-4	14'-6	15'-5	16'-6
A		Quick Clamp	12	12	12	16	16	10	16	12	16	12	20	24
B		Pole cap	6	6	6	8	8	5	8	6	8	6	10	12
C		Pole Bottom Plug	6	6	6	8	8	5	8	6	8	6	10	12
D		Upper Pole Tube	6	6	6	8	8	5	8	6	8	6	10	12
E		Lower Pole Tube	6	6	6	8	8	5	8	6	8	6	10	12
F		Foam Tube	12	12	12	16	16	10	16	12	16	12	20	24
G		Safety Net	1	1	1	1	1	1	1	1	1	1	1	1
H		Spanner	1	1	1	1	1	1	1	1	1	1	1	1

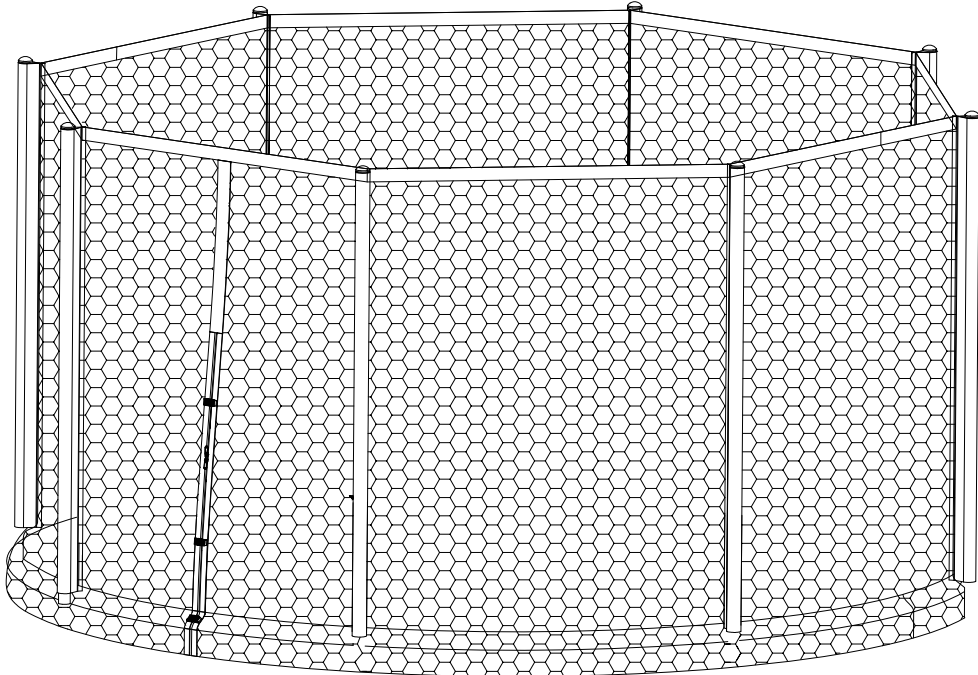

SAFETY ENCLOSURE ASSEMBLY

STEP 1

Enclosure Pole Assembly

Warning : 2 adults in good physical condition are required for the following assembly. Wear proper shoes and maintain balance to prevent a fall. Failure to follow all instructions and warnings exactly may result in serious injury.

1, Connect all Upper pole tube to the Lower pole tube as show on the picture (Note: the Upper/Lower pole tube comes with foam tube assembled)

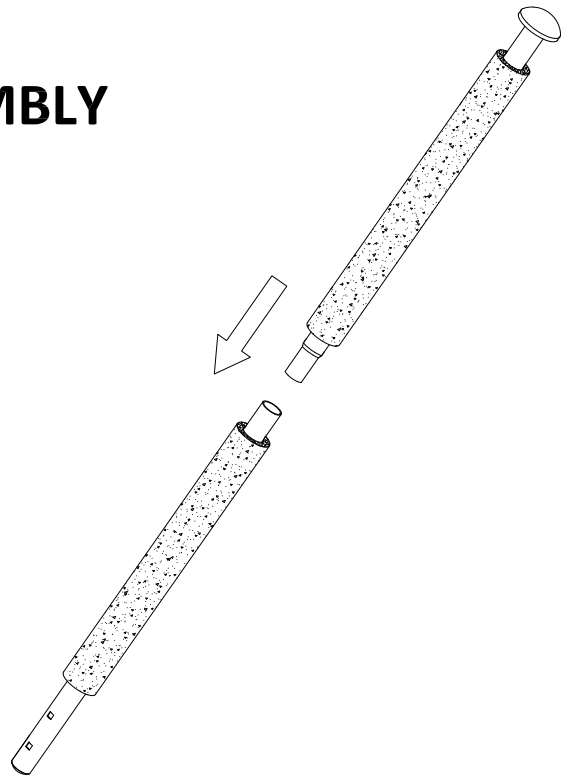

2, Align holes, secure the poles with Long Bolt, Plastic Spacer, Washer and Nut to the trampoline frame. For this step, we recommend you get help from another person ; otherwise, too difficult to hold the tube and fasten the tube.

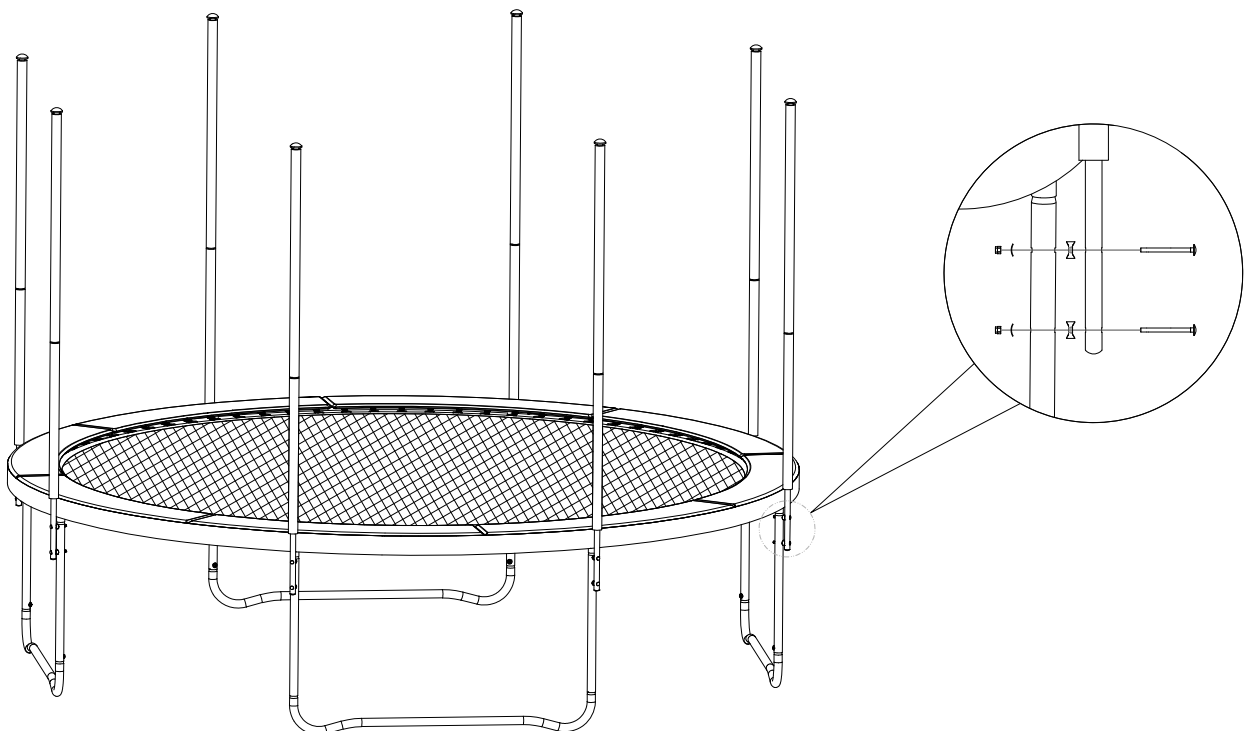

STEP 2

Safety Net Assembly

Ensure that the entrance is located between two trampoline support legs, then place the safety net pole cover into the installed pole tubes. Starting from the entrance, go left in a clockwise direction from one tube to the net. Repeat the same to secure all the Pole Tubes like picture shown.

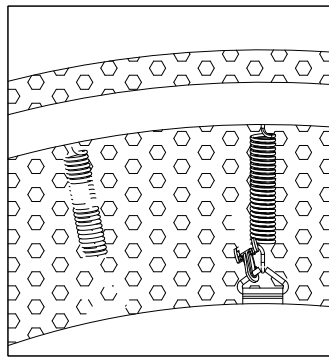
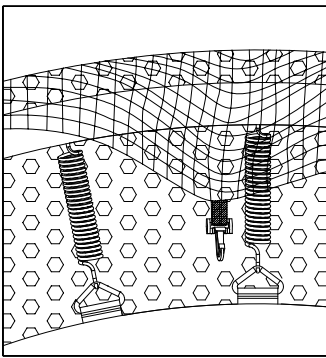
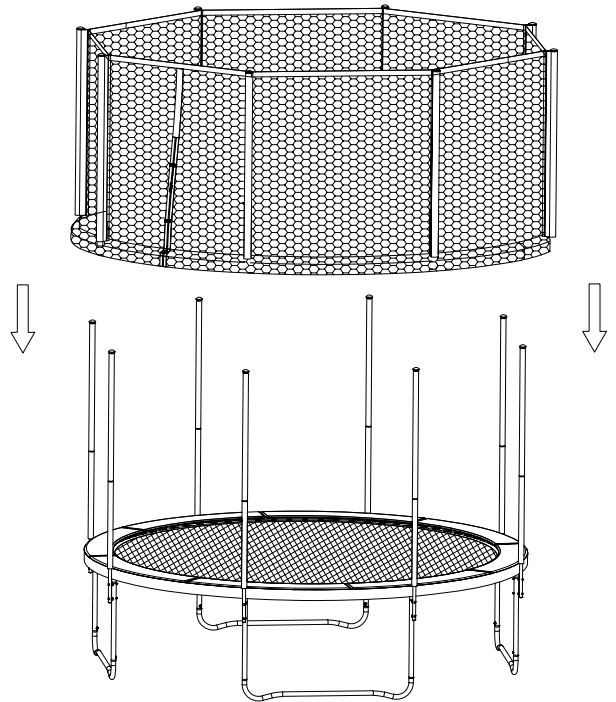

Pull the elastic with buckle at the ends of the safety net over the edge of the trampoline and hook this over the end of a trampoline jumping mat eyelet as shown in the following illustrations. Do this so that all elastic is evenly distributed and the net is stretched out.

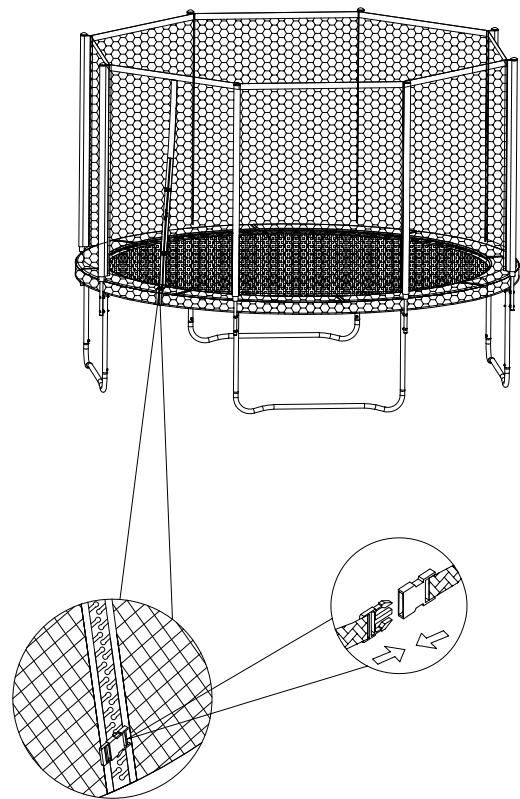

TESTING THE TRAMPOLINE

After assembling the trampoline, it is important that you perform the following safety checks:

Trampoline Safety Checks:

- Using a screw driver, check if all the screws are tightly secured.
- Look underneath the trampoline and check all the springs are hooked securely to the frame and triangle rings.
- Move the trampoline around and check the sturdiness of the frame.
- Using your two hands, put your body weight on one section of the trampoline and release to check that the floor is even.
- Inspect the cover pads and check if they completely cover the springs and frame.
- Make sure the strings of the pads are tied securely.

- **Enclosure Net Safety Checks:**
- Hold onto pole net jacket and check that all the enclosure poles are sturdy by shaking it.
- Check the enclosure net and pole jacket for any tearing in the stitching or material.
- Check the enclosure net zipper and entrance hooks function properly.
- Check to see if all safety enclosure hooks are attached to the triangle ring underneath the trampoline

Once all the checks are performed and the trampolines have passed all the initial test (above), then your trampoline has one person test the trampoline by jumping on the center continuously for 5 minutes. If the trampoline feels sturdy then your trampoline passes the test. Congratulations, you have completed the trampoline assembly! Remember to abide by all the safety rules. Have fun, play safe...

PLEASE NOTE:

AS ALREADY MENTIONED IN THE INSTRUCTION MANUAL CERTAIN WEAR AND TEAR PARTS HAVE TO BE REPLACED FROM YOUR SUPPLIER.

FUNDAMENTAL BOUNCES TECHNIQUES

All trampoline users are recommended to understand and perfect these fundamental bounces.

THE BASIC BOUNCE

- Start from a standing position, feet shoulder width apart with head and eyes on the mat
- Swing your arms forward and up and around in a circular motion.
- Bring feet together while in mid-air and point toes downward.
- Keeping feet shoulder width apart when landing on mat.

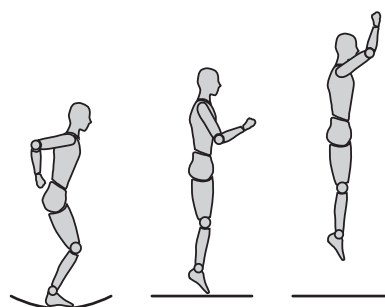

THE BRAKING MANOEUVRE

- Occasionally they may lose control of their jump and bounce wildly. Performing the braking maneuver will allow the user to regain control of the jump and their balance.
- Start with a basic bounce.
- As you land, bend your knees sharply and this will allow you to stop your jump.

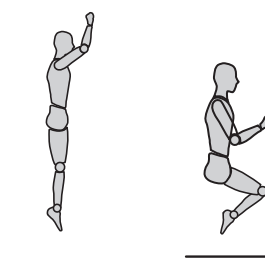

THE HANDS AND KNEES BOUNCE

- Start with a low controlled basic bounce.
- Land on your hands and knees keeping your back straight.
- Emphasis should be directed at a good four-point landing. And not on jumping height.

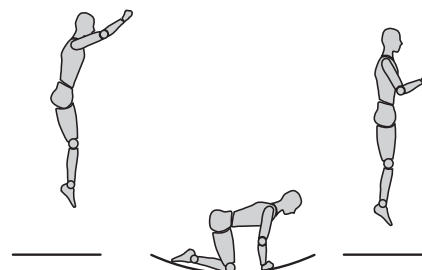

KNEE BOUNCE

- Start with a low controlled basic bounce.
- Land on your knees keeping back straight. body erect and use your arms to maintain balance.
- Bounce back to the basic bounce position by swing your arms up.

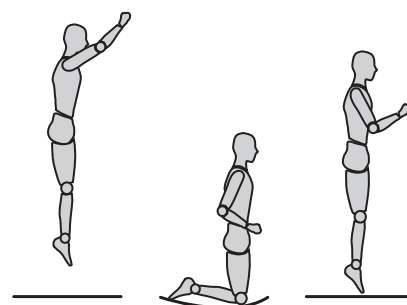

SEAT BOUNCE

- Land in a flat sitting position.
- Place hands on mat beside your hips.
- Return to erect by pushing with your hands.

