

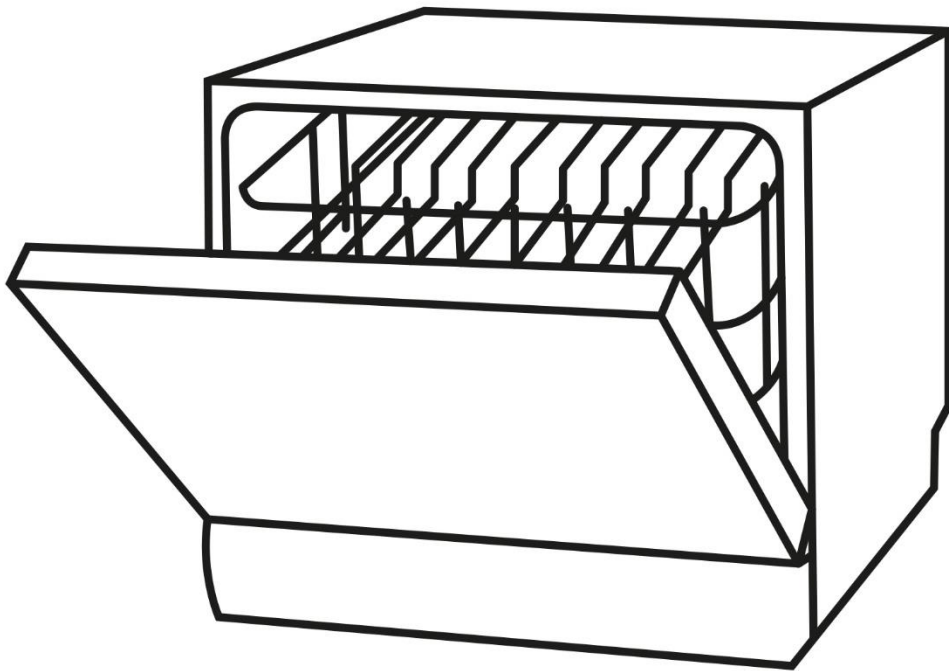

Russell Hobbs

Compact Dishwasher Instruction Manual



Model number(s):
RHTTDW6 (W) (B) (S)

IMPORTANT:
RETAIN FOR FUTURE REFERENCE

Contents

Safety instruction	3-4
Water & electrical connection	5-6
Disposal of old electrical appliances	6
Saving energy & water	7
Unpacking the dishwasher	8
Product overview	9
Unit	9
Control panel	10-11
Pre-installation	12
Water Hardness & setting the salt	12-13
Loading the salt into the container	13-14
Rinse aid dispenser	14-16
Detergent	16-19
Loading the dishwasher	20-24
Washing programs	25
Washing cycles	26-27
Installation	28-29
Drain hose connection	30-31
Water connection	32
Maintenance & Cleaning	33-37
Trouble Shooting	38-41
Connection to the Mains Supply	42
Guarantee	43
Technical Specification	44
Product Fiche	45
Notes	46-47

Safety Instructions

The appliance was designed and manufactured in compliance with current international safety standards. The following information has been provided for safety reasons and should therefore be read carefully. Keep this instruction manual in a safe place for future reference. If the appliance is sold, given away or moved, please ensure the manual is kept with the machine, so that the new owner may benefit from the advice contained within it.

Please read this instruction manual carefully: it contains important information regarding the safe installation, use and maintenance of the appliance.

- The appliance was designed for domestic use inside the home and is not intended for commercial or industrial use.
- Use the dishwasher only for its intended function.
- This appliance is not intended for use by persons (including children) with reduced physical, sensory or mental capabilities, or lack of experience and knowledge, unless they have been given supervision or instruction concerning use of the appliance by a person responsible for their safety.
- Children should be supervised to ensure that they do not play with the appliance.
- DO NOT allow children to play with the appliance or tamper with its controls.
- The appliance must be used by adults only, to wash domestic crockery according to the instructions in this manual.
- If the appliance breaks down, do not under any circumstances touch the internal parts in an attempt to carry out the repair work yourself.
- It is hazardous for anyone other than a competent person to carry out any service or repair operation that involves the removal of the cover.
- Do not tamper with the controls.
- If the supply cord is damaged, it must be replaced by the manufacturer, its service agent or similarly qualified persons in order to avoid a hazard.
- During installation, the power supply cable must not be excessively or dangerously bent or flattened.
- The appliance must not be installed outdoors, even in covered areas. It is extremely dangerous to leave the machine exposed to rain and storms.
- Do not touch the appliance when barefoot.
- When unplugging the appliance always pull the plug from the mains socket, do not pull on the cable.
- The water supply tap must be shut off and the plug should be removed from the electrical socket before cleaning the appliance or carrying out any maintenance work.
- The door should not be left open as it may create a dangerous obstacle.
- Do not operate your dishwasher unless all enclosure panels are properly in place. Open the door very carefully if the dishwasher is operating, there is a risk of water squirting out.
- Do not allow the control panel to become wet. Clean with a soft, damp cloth.

Safety Instructions

- If your family includes children:
 - Keep detergents and rinse aids away from children.
 - Keep children away from the open door of a dishwasher, there could still be some detergent left inside.
- Do not use detergents, abrasives or spray-on cleaners on the control panel.
- Dishwasher detergents are strongly alkaline, they can be extremely dangerous if swallowed. Avoid contact with skin and eyes and keep children away from the dishwasher when the door is open.
- Do not use detergents not designed for an automatic dishwasher. Never use soap, laundry detergent, or hand washing detergent in your dishwasher. Keep these products out of the reach of children.
- Ensure you do not use any corrosive chemicals or vapours in the appliance. It is not designed for industrial or laboratory use.
- You should clean your dishwasher with a damp cloth. Don't allow water to seep into any openings.
- Do not lean or sit on the open door of the appliance: this may cause the appliance to overturn.
- Never put any objects into the openings on the outer case.
- Knives and other utensils with sharp points must be loaded in the basket with their points down or placed in a horizontal position.
- Do not place any heavy objects on or stand on the door when it is open. The appliance could tip forward.
- When loading items to be washed, position sharp items so that they are not likely to damage the door seal.
- Check that the detergent compartment is empty after completion of the wash cycle.
- Do not wash plastic items unless they are marked dishwasher safe or the equivalent. For plastic items not marked, check the manufacturer's recommendations.
- The packaging material should not be used as a toy: it can become a choking or suffocation hazard.
- Packaging material could be dangerous for children!
- This appliance is intended to be used in household and similar applications such as:
 - staff kitchen areas in shops, offices and other working environments;
 - Farm houses;
 - by clients in hotels, motels and other residential type environments;
 - bed and breakfast type environments.

Important notes:

- **Any technical checks should be conducted exclusively by a trained and authorised technician: Repairs carried out by unauthorised persons will invalidate the guarantee, as well as posing a potential hazard to the user.**
- **The manufacturer declines all responsibility for damage to persons or property resulting from failure to observe the above precautions, from tampering with even a single component or from the use of non-original spare parts.**

Water and Electrical Connection

Important note: Connection to the water and electricity supplies should only be performed by a qualified technician.

Electrical Connection

Before inserting the plug into the electrical socket, make sure that:

- The socket is earthed and complies with current regulations;
- The socket can withstand the maximum load of the appliance, which is indicated on the appliance's rating
- The power supply voltage falls within appliance's rating
- The socket is compatible with the plug of the appliance. If this is not the case, ask an authorised technician to replace the plug
- Do not use extension cables or multiple sockets.
- Once the appliance has been installed, the power supply cable and the electrical socket should be easily accessible.
- The cable should not be bent or compressed.

Important notes:

- **If the power supply cable is damaged, it must be replaced by the manufacturer or its Technical Assistance Service in order to prevent all potential hazards.**
- **This appliance must be earthed.**
- **Your appliance comes fitted with a plug and a 13A fuse. If you need to replace the fuse, only those rated at 13A and ASTA approved to BS1362 should be used. Correct replacement is identified by colour coding or the marking on base of plug.**
- **DO NOT use the plug unless the fuse cover is fitted.**

Water connection

- The dishwasher should not stand on top of the water hoses or the electricity supply cable.
- If the inlet hose is not long enough, contact a specialist store or an authorised technician
- The hose should not be bent or compressed.
- The appliance must be connected to the water supply network using new hoses. Do not use old hoses.
- Ensure that the new hose supplied is connected and the old hose is disposed of safely.
- **DO NOT** overtighten the hose connector, hand tight is sufficient.
- Ensure the fill hose is not kinked.

Water and Electrical Connection

- Tap connections*: A range of adaptors are available to suit your tap.
- DO NOT connect the dishwasher to a single outlet instantaneous water heater or an electric heater.
- It MUST NOT be connected to a surface water drain.
- The maximum permissible inlet water pressure is 1Mpa.
- The minimum permissible inlet water pressure is 0.04Mpa.
- Do not abuse, sit on, or stand on the door or dish rack of the dishwasher.
- Do not obstruct any ventilation openings.

If the appliance must be moved at any time, keep it in an upright position; if absolutely necessary, it may be tilted onto its back.

Disposal of old electrical appliances

- The European Directive 2012/19/EU on Waste Electrical and Electronic Equipment (WEEE), requires that old household electrical appliances must not be disposed of in the normal unsorted municipal waste stream. Old appliances must be collected separately in order to optimise the recovery and recycling of the materials they contain and reduce the impact on human health and the environment. The crossed out “wheeled bin” symbol on the product reminds you of your obligation, that when you dispose of the appliance it must be separately collected. Consumers should contact their local authority or retailer for information concerning the correct disposal of their old appliance. Saving energy and respecting the environment.
- Please dispose of packaging and old appliances carefully.
- To minimise risk of injury to children, remove the door, plug and cut mains cable off flush with the appliance.
- Dispose of these parts separately to ensure that the appliance can no longer be plugged into a mains socket and the door cannot be locked shut.

Saving water and energy

- Only start a wash cycle when the dishwasher is full.
- While waiting for the dishwasher to be filled, prevent unpleasant odours with the Rapid Wash.
- Select a wash cycle that is suited to the type of dishes/crockery and to the soil level of the dishes/crockery using (see the washing program section): - for dishes with a normal soil level, use the Eco wash cycle, which guarantees low energy and water consumption levels.
 - if the load is smaller than usual, activate the Half load function.
- If your electricity supply contract gives details of electricity saving time bands, run wash cycles during the periods when a lower tariff is applied.
 - use the Time Delay start function to help you organise the wash cycles accordingly.
- We strongly recommend that you use detergents that do not contain phosphates or chlorine, as these products are harmful to the environment. We recommend Phosphate-free and chlorine-free detergents containing enzymes.
- Enzymes provide a particularly effective action at temperatures around 50°C, and as a result detergents containing enzymes can be used in conjunction with low-temperature wash cycles in order to achieve the same results as a normal 65°C wash cycle.
- To avoid wasting detergent, use the product in appropriate quantities based on the manufacturer's recommendations, the hardness of the water and the soil level and quantity of the crockery. Even if they are biodegradable, detergents contain substances that may alter the balance of nature.

- Recycling & Disposal Information: As part of our continued commitment to helping the environment, we reserve the right to use quality recycled components to keep down customer costs and minimise material wastage.
- Please dispose of packaging and old appliances carefully.

Unpacking the appliance

1. Remove the appliance from all packaging and check that the product has not been damaged during transportation. If it has been damaged, contact the manufacturer or the retailer and do not proceed any further with the installation process. Below are key areas to check:
 - A misaligned door
 - Damage to the door
 - Dents or holes in side panels and the top panel.
 - Dents in the inside
 - If you can see any damage **do not use the dishwasher**

Before using your dishwasher for the first time:

Before using the dishwasher for the first time you must complete the following, as failure to do so will invalidate the guarantee:

1. Connection to the water and electricity supplies should only be performed by a qualified technician.
2. Set the water softener
3. Add 1.0Kg dishwasher salt and then fully fill the salt container with water
4. Fill the rinse aid dispenser
5. Fill the detergent dispenser
6. Run the unit empty on the intensive cycle to clean out any impurities caused by the manufacturing process.

Product Overview

Front view

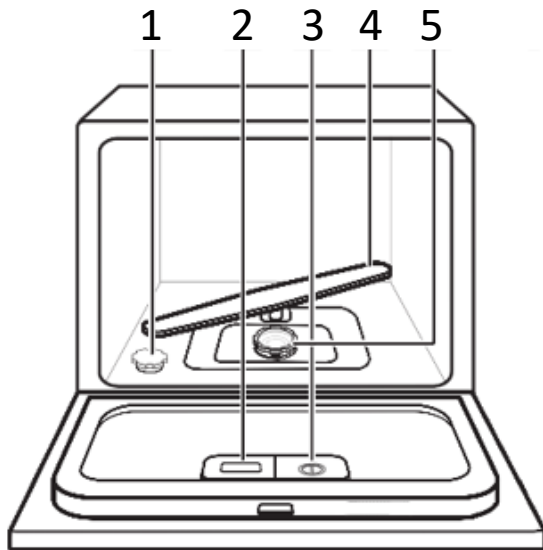

Rear view

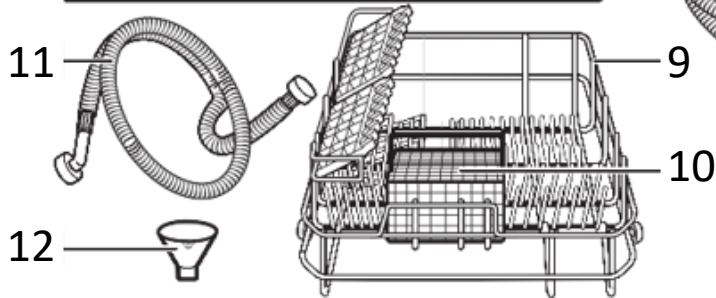
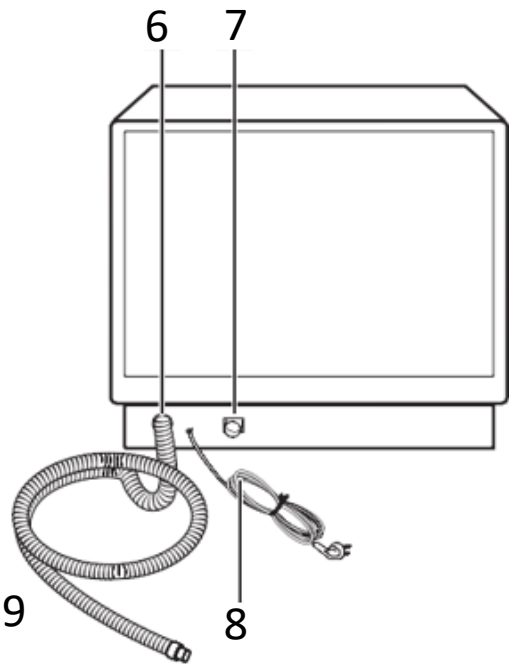

- 1. Salt aid container
- 2. Detergent dispenser
- 3. Rinse aid dispenser
- 4. Spray arm
- 5. Filter
- 6. Drain pipe

- 7. Inlet pipe connector
- 8. Power cord
- 9. Basket
- 10. Cutlery basket
- 11. Inlet hose
- 12. Salt funnel

Control Panel

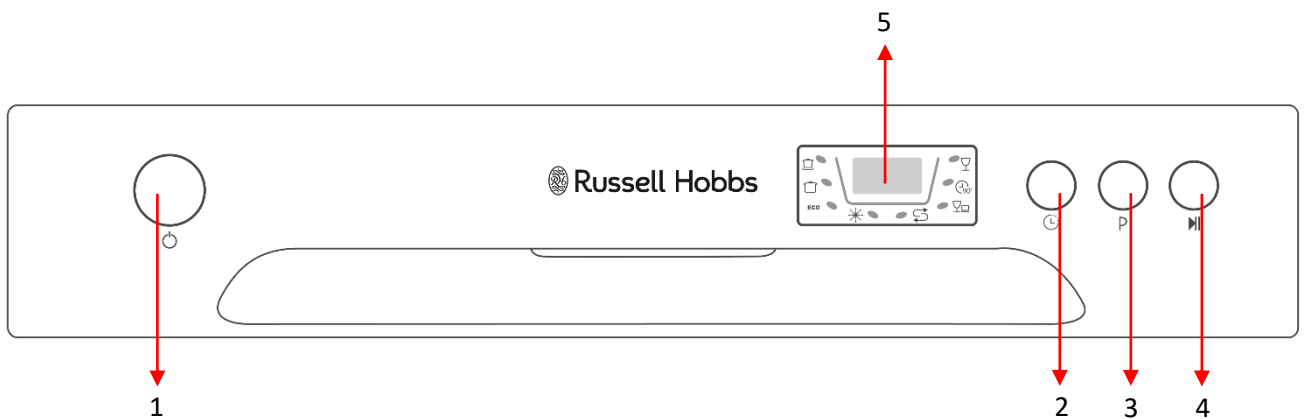

1. On/off button
2. Time delay button
3. Program button
4. Start/pause button
5. Program indicator lights, display & rinse aid + dishwasher salt warning indicator lights (when lit it needs refilling)

Control Panel Functions and Indicators

On/off button

Press to turn appliance on and off

Time delay button (1 - 24hours)

Press to select time you wish to delay the start of the wash program by (press after selecting the required program but prior to pressing the start button)

Program button

Press to select the program you wish to select, these are:

- Intensive 
- Normal 
- Eco 
- Glass 
- 90' 
- Rapid 

Please see washing programs section for the full details of the washing programs.

Control Panel

Start/pause button

Press to start the selected program or pause the washing program that is running.

Salt aid warning & rinse aid warning indicator lights

Light up when the salt container and/or rinse aid dispenser need to be refilled

Time delay indicator lights (1 - 24hours)

Light to show which delay time has been selected

Program indicator lights

Light to show which program has been selected

Pre-Installation

Important Note: Prior to installation and first use the following 4 steps must be followed, failure to do so will void your guarantee:

1. Set the water softener level
2. Add 1.0kg dishwasher salt and fill the salt container with water
3. Add rinse aid to the rinse aid dispenser
4. Fill the detergent dispenser with detergent powder or a detergent tablet

Water Hardness & Setting the Salt

The water softener must be set digitally, using the water hardness setting function. The water softener is designed to remove minerals and salts from the water, which would have a detrimental or adverse effect on the operation of the appliance. The higher the content of these minerals and salts, the harder your water is. The softener should be adjusted according to the hardness of the water in your area. Your local Water Authority can advise you on the hardness of the water in your area.

Adjusting Salt Consumption

The dishwasher is designed to allow for adjustment in the amount of salt consumed based on the hardness of the water used. This is intended to optimise and customise the level of salt consumption.

Please follow the steps below for adjustment in salt level/consumption:

1. Within 60 seconds after the appliance was switched on press and hold the 'Program' button for more than 5 seconds to start the water softener setting function. The salt warning lights will flash periodically during the water setting function.
2. Press the 'Program' button to select the required softener level in accordance with your local water hardness level. The display will show the different softener levels (please see the table on the following page). The softener levels will change in the following sequence: H1->H2->H3->H4->H5->H6 (H1 is the lowest setting and H6 is the highest setting).
3. Press the 'Program' button to set the softener level. Without any operation in five seconds, the machine will exit from set mode and going into standby mode.

Note: The hardness of the water varies from place to place. If hard water is used in the dishwasher, deposits will form on the dishes and utensils. The appliance is equipped with a special softener that uses a salt container specifically designed to eliminate lime and minerals from the water.

Water Hardness & Setting the Salt

It is recommended that adjustments should be made in accordance with the following scheme:

Softener level	Setting on the water softener	Water Hardness (Clarke)
H1	1	0-5
H2	2	6-11
H3	3	12-17
H4	4*	18-22
H5	5	23-34
H6	6	35-55

*factory setting

Note: Contact your local water board for information on the hardness of your water supply.

Loading the salt into the container

Important Note:

- Only use salt specifically designed for use in dishwashers. Every other type of salt not specifically designed for use in a dishwasher, especially table salt, will damage the water softener. In case of damage caused by the use of unsuitable salt the manufacturer do not give any warranty and we are not liable for any damage caused.
- Only fill with salt just before starting one of the complete washing programs.
- This will prevent any grains of salt or salty water, which may have been spilled, remaining on the bottom of the machine for any period of time, which may cause corrosion.

The salt container is located beneath the basket and should be filled as explained in the following section:

1. Remove the basket and then unscrew and remove the cap from the salt container. See diagram 1 on the following page.
2. Place the salt funnel that is provided into the hole and pour approximately 1.0kg of dishwasher salt into the salt container
3. Fully fill the salt container with water. It is normal for a small amount of water to come out of the salt container. See diagram 2 on the following page.
4. After filling the container, screw the cap tightly back clockwise.
5. Usually, the salt warning indicator light will stop being illuminated within 2-6 days after the salt container has been filled.

6. Immediately after filling the salt into the salt container, a washing program should be started (We suggest to use the rapid programs) Otherwise the filter system, pump or other important parts of the machine may be damaged by salty water. This may affect the guarantee.

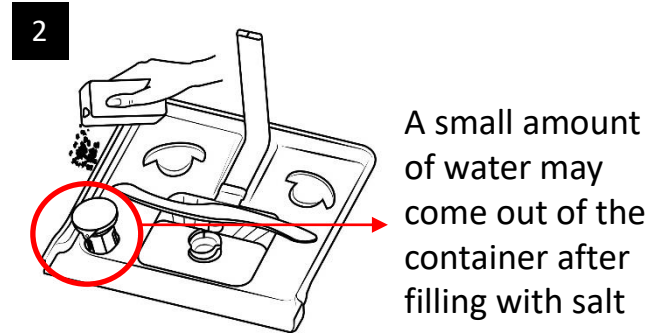
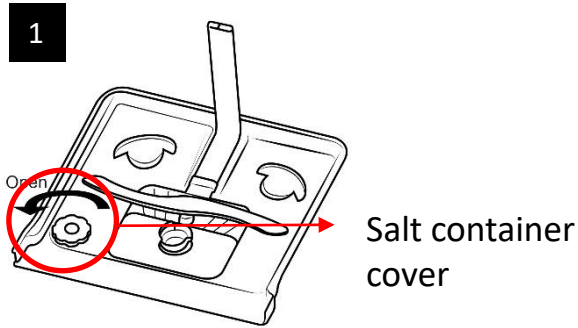

Note:

- The salt container must only be refilled when the salt warning light in the control panel comes on. Depending on how well the salt dissolves, the salt warning light may still be on even though the salt container is filled.
- If there are spills of salt, a soak or a Rapid program should be run to remove the excessive salt.

Rinse Aid Dispenser

Rinse Aid dispenser

The rinse aid is released during the final rinse to prevent water from forming droplets on your dishes, which can leave spots and streaks. It also improves drying by allowing water to roll off the dishes. Your dishwasher is designed to use liquid rinse aids. The rinse aid dispenser is located inside the door next to the detergent dispenser.

To fill the dispenser, open the cap and pour the rinse aid into the dispenser until the level indicator turns completely black. The volume of the rinse aid container is about 110ml.

Function of Rinse Aid

Rinse aid is automatically added during the last rinse, ensuring thorough rinsing, and spot and streak free drying.

Important note:

Only use branded rinse aid for dishwasher. Never fill the rinse aid dispenser with any other substances (e.g. Dishwasher cleaning agent, liquid detergent). This may damage the appliance.

When to Refill the Rinse Aid Dispenser

There is a rinse aid warning indicator light in the control panel which will light when there is no or little rinse aid in the rinse aid dispenser. Alternatively you can manually check/estimate the amount of rinse aid in the rinse aid dispenser from the colour of the optical level indicator located next to the cap. When the rinse-aid container is full, the whole indicator will be darker. As the rinse-aid diminishes, the size of the dark dot decreases. You should never let the rinse aid level fall 1/4 full.

As the rinse aid diminishes, the size of the black dot on the rinse aid level indicator changes, as illustrated below:

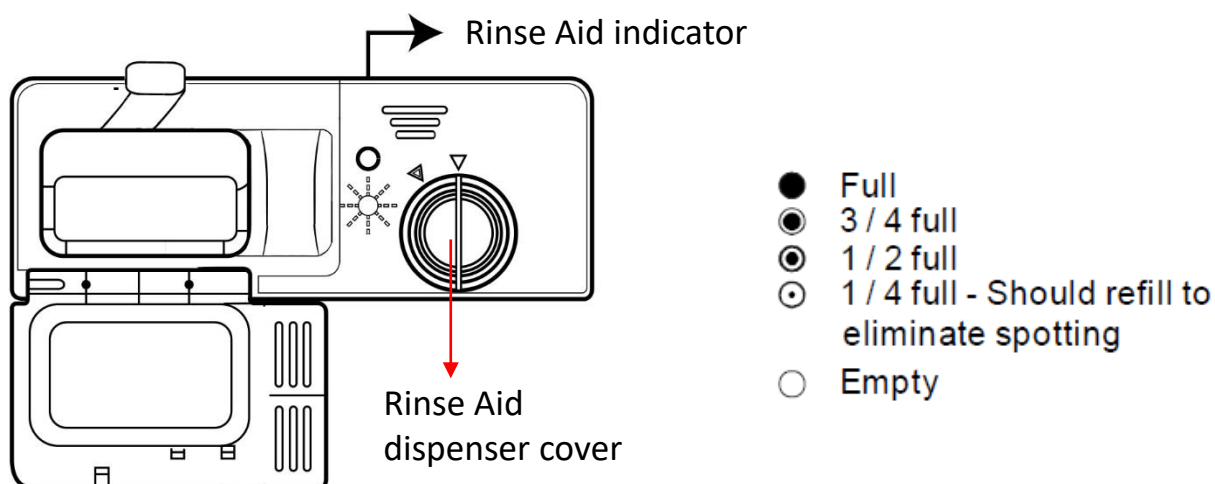

1. To open the dispenser, turn the cap to the "open" (left) arrow and lift it out.
2. Pour the rinse aid into the dispenser, being careful not to overfill.
3. Replace the cap by inserting it aligned with "open" arrow and turning it to the closed (right) arrow.

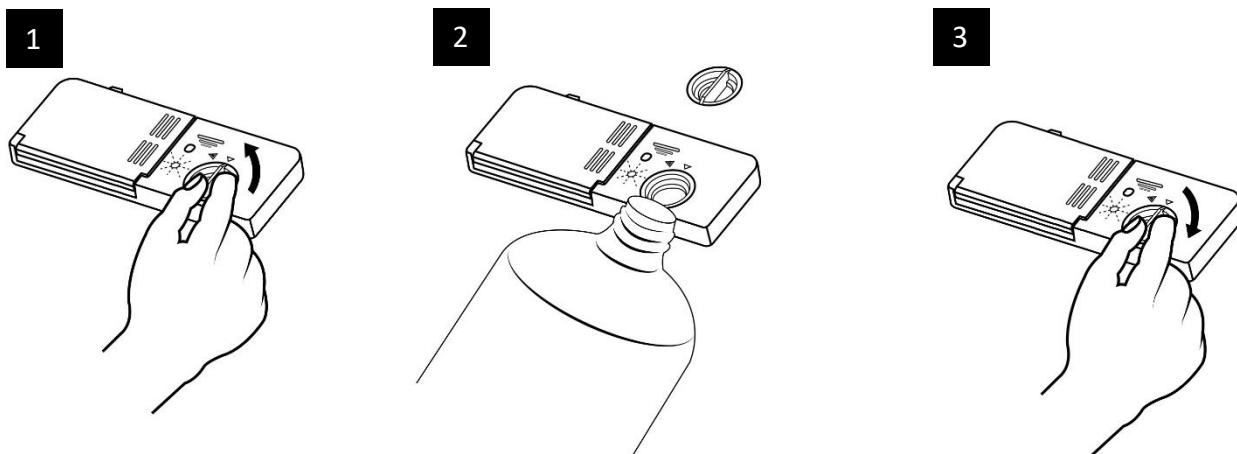

NOTE: Clean up any rinse aid spilled during filling with an absorbent cloth to avoid excessive foaming during the next wash. Don't forget to replace the cap before you close dishwasher door.

Rinse Aid Dispenser

The rinse aid dispenser has six settings. Always start with the dispenser set on "4". If spots and poor drying are a problem, increase the amount of rinse aid dispensed by removing the dispenser cover and rotating the dial to "5". If the dishes still aren't drying properly or have spots on them, adjust the dial to the next higher lever until your dishes are spot-free. The recommended setting is "4" (Factory setting is "4".)

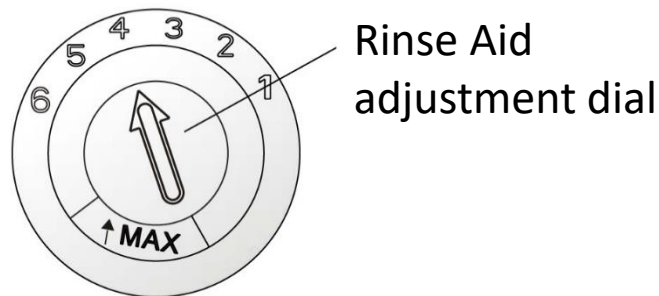

Note: Increase the dose if there are drops of water or lime spots on the dishes after washing. Reduce it if there are sticky whitish stains on your dishes or a bluish film on glassware or knife blades.

Detergent

Detergent with its chemical ingredients are necessary to remove dirt, crush dirt and transport it out of the dishwasher.

Important notes:

- Only use detergent specifically made for use in dishwashers.
- Keep your detergent fresh and dry.
- Don't put powder detergent into the dispenser until you're ready to wash dishes.
- Dishwasher detergent is corrosive! Keep it out of reach of children.

Detergents

There are 3 sorts of detergents:

1. With phosphate and with chlorine
2. With phosphate and without chlorine
3. Without phosphate and without chlorine

Detergent

Normally new pulverised detergent is without phosphate. Thus the water softener function of phosphate is not given. In this case we recommend to fill salt in the salt container even when the hardness of water is only 7*clarke. If detergents without phosphate are used in the case of hard water often white spots appear on dishes and glasses. In this case please add more detergent to reach better results. Detergents without chlorine do only bleach a little. Strong and coloured spots will not be removed completely. In this case please choose a program with a higher temperature.

Concentrated Detergent

Based on their chemical composition, detergents can be split in two basic types:

- conventional, alkaline detergents with caustic components
- low alkaline concentrated detergents with natural enzymes

Detergent Tablets

Detergent tablets of different brands dissolve at different speeds. For this reason some detergent tablets cannot dissolve and develop their full cleaning power during short programs. Therefore please use long programs when using detergent tablets, to ensure the complete removal of detergent residuals.

Detergent Dispenser

The dispenser must be refilled before the start of each wash cycle following the instructions provided in the wash cycle table. Generally, only one tablespoon of detergent is needed for a normal wash load. More heavily soiled items will need more detergent. Always add the detergent just before starting the dishwasher, otherwise it could get damp and will not dissolve properly if added mid cycle.

Detergent

Detergent Dispenser

The detergent dispenser is located on the inside of the dishwasher door and is approximately halfway up the door. The dispenser can be filled with either detergent powder or a detergent tablet, compartment A can be loaded with detergent powder or a detergent tablet and compartment B can be loaded with Pre-wash cycle detergent

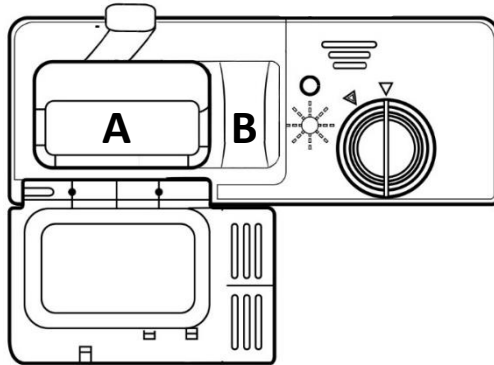

Filling the Detergent Dispenser

Note: observe the dosing and storage recommendations that are stated on the detergent packaging.

1. The detergent dispenser will automatically open during a washing cycle to release the detergent powder or detergent tablet into the appliance. However should you need to manually open the dispenser you can do this by pushing the latch on top of the dispenser, the dispenser door will spring open

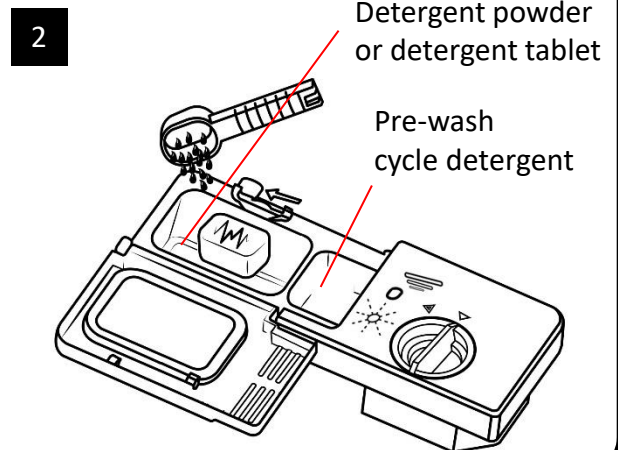
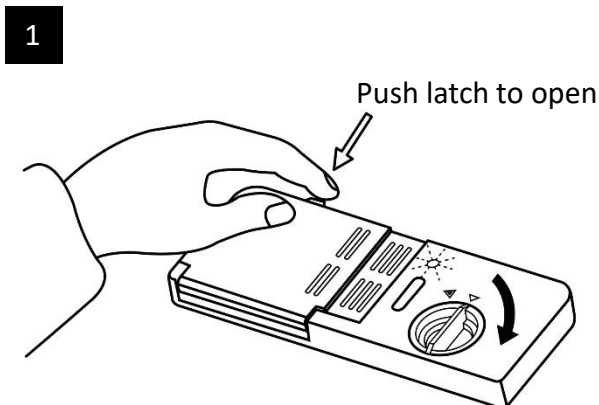

Detergent

2. Fill the detergent dispenser with the correct amount of detergent powder in compartment A or 1 detergent tablet. If the dishes are heavily soiled, place an additional detergent dose in compartment B, this detergent will take effect during the pre-wash phase (this is not required if using a detergent tablet).

Information about the amount of detergent for each program can be located in the program information section. Please be aware that the amount of detergent that is to be used can be affected by the level soiling of your dishes and the water hardness of the area you live in. Please observe the manufacturer's recommendations on the detergent packaging.

Note:

- **Only use detergent specifically made for use in dishwashers.**
- **Observe the dosing and storage recommendations that are stated on the detergent packaging.**
- **Don't put powder detergent into the dispenser until you're ready to wash dishes.**
- **Dishwasher detergent is corrosive! Keep it out of reach of children**

3. Close the lid and press until it locks in place.

Loading the Dishwasher

Notes:

- Only purchase and wash utensils which are identified as dishwasher safe.
- Use a mild detergent that is described as 'kind to dishes'. If necessary, seek further information from the detergent manufacturers.
- For particular items, select a program with as low a temperature as possible.
- To prevent damage, do not take glass and cutlery out of the dishwasher immediately after the program has ended.

Items not suitable for the dishwasher

- Cutlery with wooden, horn china or mother-of-pearl handles
- Plastic items that are not heat resistant
- Older cutlery with glued parts that are not high temperature resistant
- Bonded cutlery items or dishes
- Pewter or copper items
- Crystal glass
- Steel items are subject to rusting, specifically knife steel.
- Wooden platters
- Items made from synthetic fibres

Items that may not be suitable for the dishwasher

- Some types of glasses can become dull after a large number of washes
- Silver and aluminium parts have a tendency to discolour during washing
- Glazed patterns may fade if machine washed frequently

Before Loading the Dishwasher

For best performance of the dishwasher, follow these loading guidelines (Features and appearance of baskets and cutlery baskets may vary from your model):

1. Scrape off any large amounts of left over food from dishes/crockery
2. Soften remnants of burnt food in pans and other crockery.
3. Place objects in the dishwasher in the following way:
 - a. Items such as cups, glasses, pots/pans, etc. are faced downwards.
 - b. Curved items, or ones with recesses, should be loaded at an angle so that water can run off.
 - c. All utensils are stacked securely and can not tip over.

Loading the Dishwasher

- d. All utensils are placed in the way that the spray arms can rotate freely during washing.
 - e. Load hollow items such as cups, glasses, pans etc. with the opening facing downwards so that water cannot collect in the container or a deep base.
 - f. Dishes and items of cutlery must not lie inside one another, or cover each other.
 - g. To avoid damage to glasses, they must not touch.
 - h. Long and/or sharp items of cutlery such as carving knives must be positioned horizontally in the basket. Long bladed knives stored in an upright position are a potential hazard!
4. Do not overload your dishwasher. This is important for good results
 5. Very small items should not be washed in the dishwasher as they could easily fall of the basket
 6. Long items, serving cutlery, salad servers and knives should be placed on the shelf so that they do not obstruct the rotation of the spray arms.
 7. Pots, serving bowls, etc. must always be placed top down.
 8. Deep pots should be slanted to allow water to flow out.
 9. The basket features folding spikes so that larger or more pots and pans can be loaded.

Loading the Dishwasher

Loading the Basket

The rows of the prongs in the basket can be lowered to load pots and bowls.

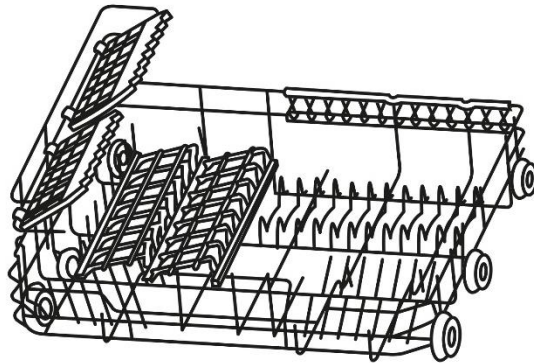

Position the dishes and cookware so that they will not get moved by the spray of water. It is preferable to place serving dishes and lids on the side of the racks in order to avoid blocking the rotation of the top spray arm.

The below diagram is an example of how to load the basket:

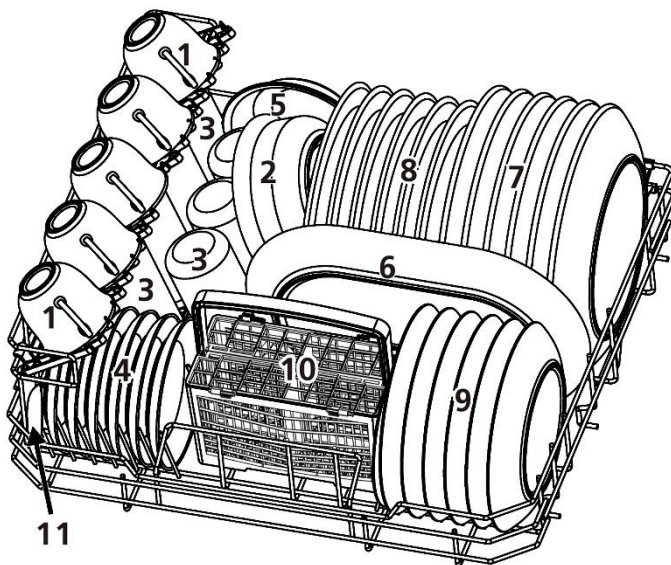

Number	Item
1	Cups
2	Medium serving bowl
3	Glasses
4	Saucers
5	Dish
6	Oval platter
7	Dinner plates
8	Soup plates
9	Dessert dishes
10	Cutlery basket
11	Serving spoons

Notes:

- Pots, serving bowls, etc., must always be placed top down
- Deep pots should be slanted to allow water to flow out
- The basket features folding spikes so that larger/more pots and pans can be loaded.

Loading the Dishwasher

Cutlery Basket

Cutlery should be placed in the cutlery basket with the handles at the bottom, except for knives and other utensils with sharp points must be loaded in the basket with their points down or placed in a horizontal position. Long utensils should be placed in the horizontal position at the front of the basket as shown in the picture.

For the best cleaning performance place the cutlery in the basket separately, you must make sure that they do not nest/group together.

Loading the Dishwasher

The compartments of the cutlery basket can be adjusted by folding over the 2 separating covers:

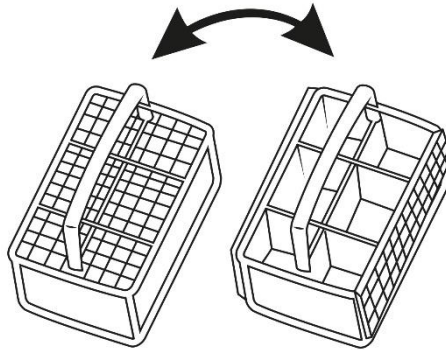





Do not let any item extend through the bottom.



Removing the dishes

- It is normal that the dishwasher is wet inside.
- It is recommend to wait for the drying cycle (if the program that has been selected has this) to finish and for the dishes/crockery to cool before removing them

Washing Programs

Program	Cycle information	Cycle stages	Detergent dosage	Running time (mins)	Energy cons. (Kwh)	Water cons. (litres)	Rinse aid required	Delay timer function
 Intensive	for heavily soiled crockery and normally soiled pots, pans, glasses and dishes (can be used for dishes with dried on soiling)	Pre-wash (50°C) Wash (70°C) Rinse Rinse Rinse (70°C) Drying	Powder: 4g/10g or Tablet: 3 in 1	140	1.2	9.6	Yes	Yes
 Universal	for normally soiled loads such as pots, dishes, glasses and lightly soiled pans	Pre-wash Wash (60°) Rinse Rinse (70°C) Drying	Powder: 4g/10g or Tablet: 3 in 1	120	1.05	7.7	Yes	Yes
*Eco Eco	for normally soiled loads such as pots, dishes, glasses and lightly soiled pans. This is the most efficient program for water consumption and energy	Pre-wash Wash (45°C) Rinse (65°C) Drying	Powder: 14g or Tablet: 3 in 1	230	0.613	6.5	Yes	Yes
 Glass	for normally soiled loads that need a quick wash	Wash (45°C) Rinse Rinse (60°C) Drying	Powder: 14g or Tablet: 3 in 1	75	0.65	5.8	Yes	Yes
 Quick 90'	A quick wash for lightly solid loads	Wash (65°C) Rinse Rinse Rinse (70°C) Drying	Powder: 14g or Tablet: 3 in 1	90	1.1	6.6	Yes	Yes
 Rapid 30'	for lightly soiled loads that don't need drying	Wash (40°) Rinse Rinse	Powder: 12g	30	0.5	5.8	No	Yes

Washing Cycles

Turning on the appliance

Starting the wash cycle

1. Pull out the basket, load the dishes (see the loading the dishwasher section).
2. Pour in the detergent powder or put in the detergent tablet into the detergent dispenser (see the detergent section) and close the detergent dispenser cover.
3. Insert the plug into the socket. The power supply must be 220-240 AC / 50Hz,
4. Make sure that the water supply is turned on to full pressure.
5. Close the door and press the ON/OFF button.
6. Select your required program by pressing the PROGRAM button (the indicator light of the program you have selected will light up).
7. If required select the delay timer function.
8. Press the start button, the machine will beep and the washing cycle will begin.

Change the program

A cycle that is underway can only be modified if it has only been running for a short time. Otherwise, the detergent may have already been released, and the appliance may have already drained the wash water. If this is the case, the detergent dispenser must be refilled (see the Detergent section).

If you wish to change the program and it is possible, then press the start/pause button, then press and hold the PROGRAM button for more than 3 seconds. The machine will enter the standby state, at this point you can now select the program you require by pressing the PROGRAM button. Once this has been done press the start/pause button and the wash cycle will begin.

Note: If you open the door during a wash cycle, the machine will pause. The buzzer will beep every minute unless you close the door. After you close the door, the machine will continue to work after 10 seconds.

Time delay

The starting time of a washing programme can be delayed, please follow the steps below:

1. Open the dishwasher door, load your soiled dishes/crockery and add detergent and then close the door.
2. Press the on/off button to turn on the dishwasher and select your preferred program.

Washing Cycles

3. Press the Time Delay button and set the required delay start time (this will be shown by time delay the indicator lights).
4. Press the start button, the unit will start the programme at the assigned time automatically.

Adding a dish during a cycle

If you have forgotten to load a dish then it can be added at any time before the detergent is dispensed. Please follow the below steps when adding a forgotten dish:

1. Open the door slightly to stop the washing.
2. After the spray arms stop working, you can open the door completely.
3. Load the forgotten dish or dishes.
4. Close the door, the dishwasher will start running again after 10 seconds.

Note: It is dangerous to open the door when washing, because the hot water may scald you.

At the end of the wash cycle

When a program has finished, the buzzer of the dishwasher will sound for 8 seconds, after this duration it will stop. Turn off the appliance using the ON/OFF button and open the door of the dishwasher. Turn off the water tap if necessary

Note: The appliance will switch off automatically 30 minutes after the program has finished.

Open the door carefully

Hot dishes are sensitive to knocks. The dishes therefore must be allowed to cool down for approximately 15 minutes before removing from the appliance. Open the dishwasher's door, leave it ajar and wait approximately 15 minutes before removing the dishes. In this way they will be cooler and the drying will be improved.

Unloading the dishwasher

It is normal that the dishwasher is wet inside. It is recommend to wait for the drying cycle (if the program that has been selected has this) to finish and for the dishes/crockery to cool before removing them.

Installation

- This appliance can be installed as a freestanding unit only.
- We recommend that 2 people handle the dishwasher during installation.
- Avoid damaging the product during installation, positioning of the appliance requires two people in order to avoid injuries or damage to the appliance.
- Be sure to wear gloves when installing the appliance to avoid personal injury, edges of the door and other parts of the appliance are sharp.
- Your appliance should not be located in direct sunlight or exposed to continuous heat or extremes of temperature (e.g. next to a radiator, boiler or cooker). If this is not feasible, then you should install an insulation plate between the appliance and the adjacent heat source.
- You should check whether there is an electrical socket available, which will be accessible after your appliance is installed.
- Place the appliance flatly and firmly on a solid base.
- All parts removed must be saved to do the reinstallation in the future. Ensure the dishwasher is unplugged and empty.
- Be sure to leave enough space for the opening of the door, to avoid damage to the appliance or personal injury.
- The installation position of dishwasher should be near the existing inlet and drain hoses and power point.
- The side of the cabinet that is adjacent to the water supply and drainage should be chosen to facilitate the connection of water inlet hose and drain hose of the dishwasher.
- For personal safety: Do not use an extension cord or an adapter plug with this appliance.
- Do not, under any circumstances, cut or remove the earthing connection from the power cord
- Ensure the power cord is not underneath any of the appliances feet or trapped by any part of the appliance.

Positioning the appliance

Position the appliance in the desired location. The back should rest against the wall behind it, and the sides, along the adjacent cabinets or walls. The dishwasher is equipped with water supply and drain hoses that can be positioned either to the right or the left sides to facilitate proper installation.

Make sure to position the appliance with minimum space of 50mm on both sides of the fully open door.

Keep 5 mm distance between both sides of the appliance and the cabinet.

Installation

If the dishwasher is going to be slotted in to a cabinet then the minimum aperture dimensions have to be: (H)458 x (W)555 x (D)550mm:

Note: To facilitate a proper installation, position the power cord, drain hose and water supply line hole to the right or the left of the appliance.

Power cord, drain hole & water supply cut out

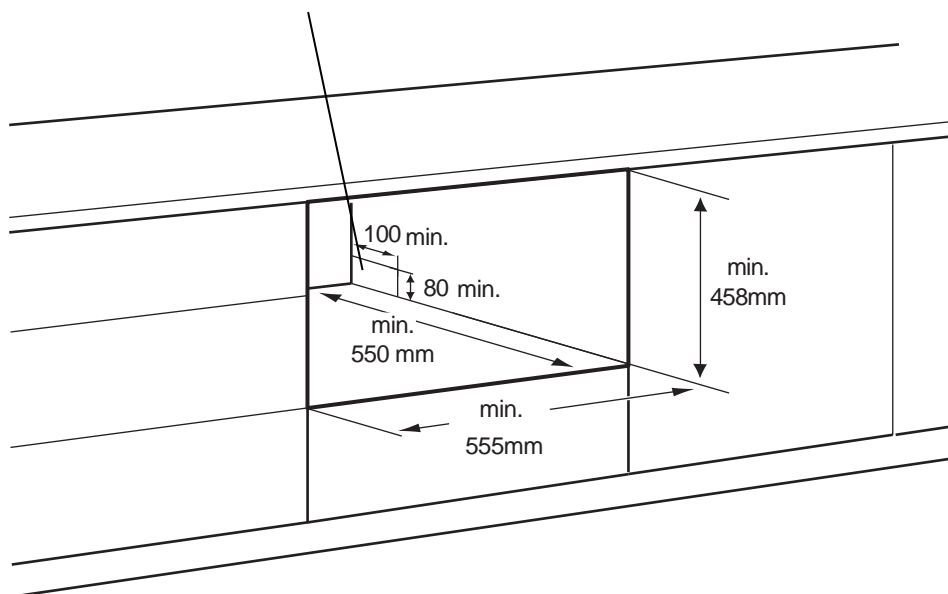

Connection of the Water Supply & Drain Hose

Important notes:

- Connection to the water and electricity supplies should only be performed by a qualified technician.
- The dishwasher should not stand on top of the water hoses or the electricity supply cable. The water inlet and outlet hoses and the electricity supply cable may be positioned towards the right or the left in order to achieve the best possible installation.

Connection of the Drain hose

Important notes:

- Before connecting the drain hose, remove any internal restrictions; this will prevent a build up of debris which could cause a blockage, remove any restrictions from the waste spigot and ensure that the sealing bung is removed.
- It **MUST NOT** be connected to a surface water drain.
- Do Not connect the dishwasher to the drain with an extended drainage hose (use the ones supplied with the appliance), if an extension hose is needed then a pump must be installed to pump the drainage through and out.

Insert the drain hose into a drain pipe that has a minimum diameter of 4cm (40mm) making sure to avoid bending or crimping it. The free end of the hose must be at a height lower than 60cm/600mm and must not be immersed in water to avoid the back flow of it. The top of the hose must be at a height between 20cm/200mm (B on the diagram) and 60cm/600mm (A on the diagram). The free end of the hose must not be immersed in water to avoid the back flow of it.

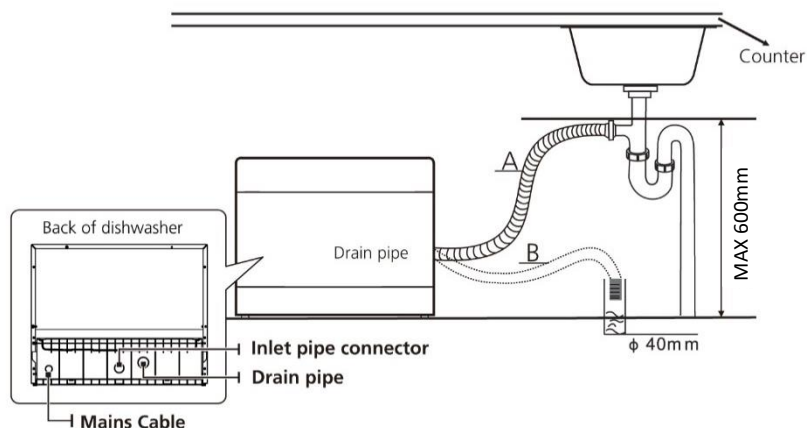

Connection of the Water Supply & Drain Hose

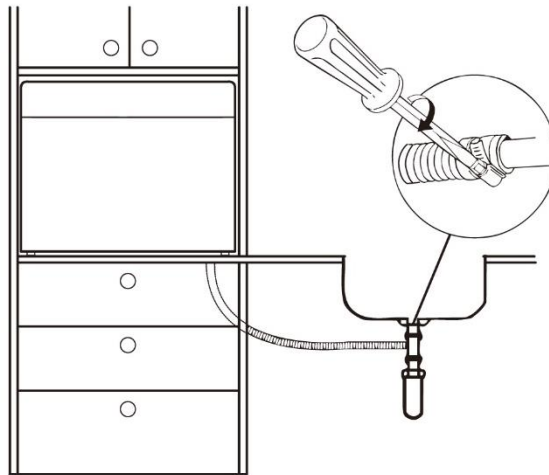

- Ensure the drain hose is securely attached, to prevent it coming away while the machine is in use and causing a flood.
- Fit the end drain hose that is connected to the waste pipe securely by using a “Jubilee” type clip.
- If the sink is 1000 higher from the floor, the excess water in hoses cannot be drained directly into the sink. It will be necessary to drain excess water from hoses into a bowl or suitable container that is held outside and lower than the sink.
- The water drain hose must be less than 600 mm from the bottom of the appliance to prevent problems during the draining phases.
- Remove the sink plug when the appliance drains water to prevent that the water goes back into the appliance.
- If you connect the water drain hose to a trap spigot under the sink, remove the plastic membrane (A). If you do not remove the membrane, remaining food can cause a blockage in the drain hose spigot.

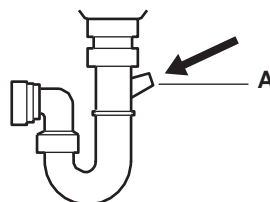

Connection of the Water Supply & Drain Hose

Connection of the Water Supply

Important note: Before attaching the water inlet hose, run the water until it is perfectly clear so that any impurities that may be present in the water do not clog the appliance. This precaution is needed to avoid the risk of the water inlet getting blocked and damaging the appliance.

Connect the water inlet hose to a threaded 3/4(inch) connector and make sure that it is fastened tightly in place. The water inlet hose must be connected to a cold water supply.

Notes:

- If the inlet hose is not long enough, contact a specialist store or an authorised technician.
- The maximum permissible inlet water pressure is 1Mpa.
- The minimum permissible inlet water pressure is 0.04Mpa.
- The hose should not be bent or compressed.
- The appliance must be connected to the water supply network using new hoses.
- Do not use old hoses.
- Ensure that the new hose supplied is connected and the old hose is disposed of safely.
- DO NOT overtighten the hose connector, hand tight is sufficient.
- Ensure the fill hose is not kinked.
- DO NOT connect the dishwasher to a single outlet instantaneous water heater or an electric heater.

Before First Use

Before the first use of the dishwasher after installation you must check for the following points:

1. All packing materials and printings have been removed from the dishwasher
2. The dishwasher is level and fixed properly
3. The water inlet valve is open
4. There is no leakage at the connections water inlet hose and the water inlet valve or the drain hose and the drain.
5. The inlet and drain hoses are knotted
6. The wires are tightly connected and not trapped
7. The power is switched on

Maintenance & Cleaning

Filtering System

The filter prevents larger remnants of food or other objects from getting inside the pump. The residue may block the filter, in this case they must be removed.

The filter system consists of a coarse filter, a flat (Main filter) and a micro filter (Fine filter).

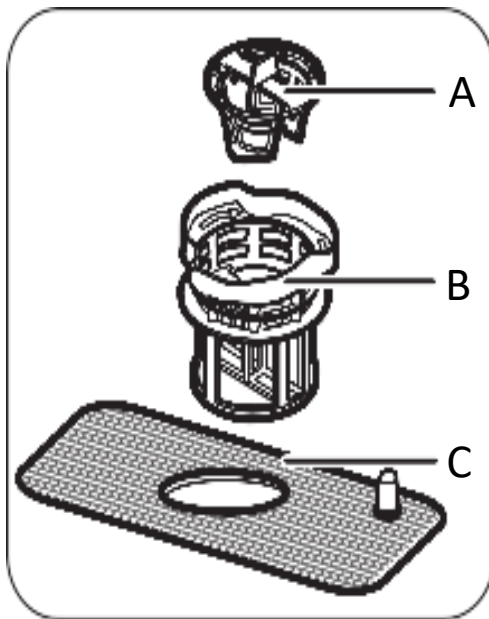

A) Coarse Filter

Larger items, such as pieces of bones or glass, that could block the drain are trapped in the coarse filter. To remove the items caught by the filter, gently squeeze the tap on the top of this filter and lift out.

B) Fine filter

This filter holds soil and food residues in the sump area and prevents it from being redeposit on the dishes during wash cycle.

C) Main Filter

Food and soil particles trapped in this filter are pulverized by a special jet on the spray arm and washed down to drain.

Filter Assembly

Important notes:

- **The dishwasher must never be used without the filters.**
- **Improper replacement of the filter may reduce the performance level of the appliance and damage dishes and utensils.**
- **Do not over tighten.**

The filter efficiently removes particles of food from the wash water, allowing it to be recycled during the wash cycle. For best performance and cleaning results, the filter must be cleaned regularly. For this reason, it is recommended to remove the larger food particles trapped in the filter after each use by removing all debris from all parts of the filter (you may need to use a cleaning brush to remove all debris from the coarse and fine filters) and rinse all parts of the filter under running water.

Maintenance & Cleaning

To remove the filter device, twist the coarse filter (B) and pull it in a upwards direction. All parts of the filter will lift away from the bottom of the appliance

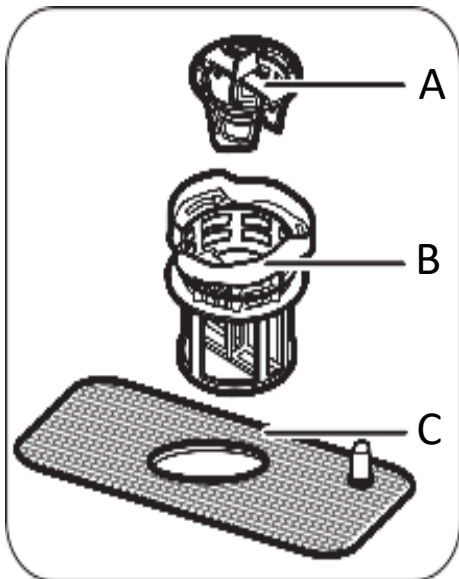

1. Turn the fine filter (B) in anti-clockwise direction, then pull it in a upwards direction
2. Remove the coarse filter (A) by pulling it from the fine filter (B)
3. Remove the main filter (C) by pulling it from the base of the cavity
4. To replace the filter reverse steps 1, 2 and 3.

Important notes:

- Inspect the filters for blocking after every use
- The filter system must be cleaned at least once a week
- When cleaning the filters, don't knock/tap them. Otherwise, the filters could be contorted and the performance of the dishwasher could be affected.

Maintenance & Cleaning

Cleaning the door

Important note:

Never use a spray cleaner to clean the door panel as it may damage the door lock and electrical components.

Abrasive agents or some paper towels should not be used because of the risk of scratching or leaving spots on the stainless steel surface.

The control panel can be cleaned by using a lightly dampened cloth. After cleaning, make sure to dry it thoroughly.

Never use sharp objects, scouring pads or harsh cleaners on any part of the dishwasher.

To clean the edge around the door, you should use only a soft warm, damp cloth. To avoid penetration of water into the door lock and electrical components, do not use a spray cleaner of any kind.

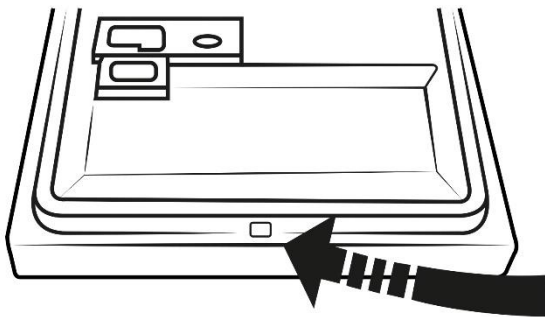

door lock and electrical components

Protect Against Freezing

Important note:

If your dishwasher cannot work because of the ice, please contact professional service persons.

You must take frost protection measures for the dishwasher in winter, if it is used in a cold environment. Every time after washing cycles, please operate as follows

Maintenance & Cleaning

1. Cut off the electrical power to the dishwasher.
2. Turn off the water supply and disconnect the water inlet pipe from the water valve.
3. Drain the water from the inlet pipe and water valve. (Use a bowl to catch the water)
4. Reconnect the water inlet pipe to the water valve.
5. Remove the filter at the bottom of the tub and use a sponge to soak up water in the sump

Cleaning the Spray Arms

It is necessary to clean the spray arm regularly for hard water chemicals, as these will clog the spray arm jets and bearings.

To remove the spray arm, pull the spray arm upward.

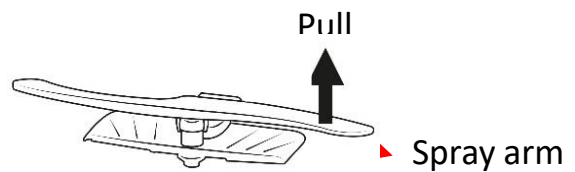

Wash the arm in warm soapy water and use a soft cleaning brush to clean the jets. Replace it after rinsing them thoroughly in clean water

How to Keep your Dishwasher in the Correct Condition

After Every Wash

After every wash, turn off the water supply to the appliance and leave the door slightly open so that moisture and odours are not trapped inside.

Remove the Plug from the socket

Before cleaning or performing maintenance, always remove the plug from the socket.

Maintenance & Cleaning

No Solvents or Abrasive Cleaning

To clean the exterior and rubber parts of the dishwasher, do not use solvents or abrasive cleaning products. Only use a cloth with warm soapy water.

To remove spots or stains from the surface of the interior, use a cloth dampened with water and a little vinegar, or a cleaning product made specifically for dishwashers.

When not in use for a long time

It is recommended that you run a wash cycle with the dishwasher empty and then remove the plug from the socket, turn off the water supply and leave the door of the appliance slightly open. This will help the door seals to last longer and prevent odours from forming within the appliance.

Moving the Appliance

If the appliance must be moved, try to keep it in the vertical position. If absolutely necessary, it can be positioned on its back but cannot be left in this position.

Seals

One of the factors that cause odours to form in the dishwasher is food that remains food debris and moisture in the seals. Periodic cleaning these with a damp sponge will prevent this from occurring.

Trouble Shooting

Problem	Causes	Solution
Dishwasher doesn't start	Power supply is not turned on	Make sure the power cord is properly plugged into the wall socket. Make sure the dishwasher is turned on and the door is closed securely.
	Fuse blown, or the circuit breaker acted	Replace fuse or reset circuit breaker. Remove any other appliances sharing the same circuit with the dishwasher
	Water supply is not turned on	Check that the water supply is connected properly and the water is turned on.
	Water pressure is low	Check that the water pressure is within the required level, please see water connection section.
	Door of dishwasher not properly closed.	Make sure to close the door properly/full.
	A fault has occurred	Switch of the appliance by pressing the ON/OFF button , switch it back on after approximately one minute and reset the program. If this does not work unplug the appliance and leave for 5 minutes, then put the plug back in and turn on the appliance.
Water has not drained for the dishwasher	Wash program has not finished	The wash program may not have finished, close the door and wait for the wash program to complete in full
	Drain hose is bent	Check drain hose.
	Filter clogged/blocked	Check all parts of the filter and clean if necessary, please see filter section.
	Drains clogged/blocked	Check the drains to make sure they are draining well. If they aren't you will need to get them unblocked and may need a plumber to do this. If the dishwasher still won't drain then a service engineer may be needed.
The dishwasher does not take any water	There is no water in the mains supply	Check the water supply has not been cut off or if there is a fault in your area.
	Water inlet pipe is bent	Water inlet pipe.
	Turn on the water tap and/or vale	Turn on the water tap/valve and the appliance will start after a few minutes.

Trouble Shooting

Problem	Causes	Solution
Suds in the tub	Improper detergent	Use only the dishwasher detergent to avoid suds. If this occurs, open the dishwasher and let suds evaporate. Pour 1 gallon of cold water to the tub, then close the dishwasher and select any cycle. The first part of the cycle will see the dishwasher drain out the water (you will be able to hear this taking place). When the draining has finished open the door and check if the suds is disappeared. Repeat if necessary.
	Spilled rinse-aid	Always wipe up rinse-aid spills immediately, because if left in the tub then suds will be produced.
Stained tub interior	Detergent with colourant was used	Make sure that the detergent is the one without colourant.
White film on inside surface	Hard water minerals	To clean the interior, use a damp sponge with dishwasher detergent and wear rubber gloves. Never use any other cleaner than dishwasher detergent for the risk of foaming or suds.
There are rust stains on cutlery	The affected items are not corrosion resistant	Purchase dishwasher safe cutlery or hand wash the cutlery that isn't dishwasher safe
	A program was not run after dishwasher salt was added. If this is done then traces of salt will get into the wash cycle and cause corrosion	Always run the quick wash program after adding dishwasher salt without any crockery in the dishwasher.
	The lid of the water softener is loose	Check the lid and ensure it is fitted correctly and tight.
Knocking noise in the wash cabinet	A spray arm is knocking against an item in a basket	Interrupt the program, and rearrange the items which are obstructing the spray arm.
Rattling noise in the wash cabinet	Items of crockery are loose in the wash cabinet	Interrupt the program, and rearrange the items of crockery.
Knocking noise in the water pipes	This may be caused by on-site installation or the cross-section of the piping	This has no influence on the dishwasher function, if in doubt, contact a suitably qualified plumber.

Trouble Shooting

Problem	Causes	Solution
The dishes are not clean	Dishwasher has been overloaded	Arrange the dishes correctly or wash in 2 separately loads, please see the Loading the Dishwasher section.
	The dishes were not loaded correctly	Arrange the dishes correct, please see the Loading the Dishwasher section.
	The program was not powerful enough	Select a more intensive program, please see the Wash Program section.
	Not enough detergent was dispensed.	Use more detergent, or change your detergent.
	Too much detergent was dispensed or the incorrect detergent has been used	The detergent has not been measured out correctly or it is not suitable for use in dishwashers
	Items are blocking the path of spray arms	Re-arrange the items so that the spray can rotate freely.
	The filter in the base of wash cabinet is not clean or is not correctly fitted. This may cause the spray arm jets to get blocked	Clean and/or fit the filter correctly. Clean the spray arm jets, please see the Cleaning the Spray Arms section
	Insufficient dishwasher salt and Rinse aid need to be refilled	Dishwasher salt and Rinse-aid need to be refilled, please see the Dishwasher Salt and Rinse Aid sections.
	The lid on the rinse-aid dispenser was not shut correctly	Shut correctly and re-wash
The dishes and glasses are streaked or have a bluish tinge	The rinse-aid dosage is too high.	Reduce the rinse-aid dosage
Cloudiness on glassware	Combination of soft water and too much detergent	Use less detergent if you have soft water and/or select a shortest cycle to wash the glassware and to get them clean. The Glass Wash program could be used.
Black or grey marks on dishes	Aluminium utensils have rubbed against dishes	Use a mild abrasive cleaner to eliminate those marks.
Detergent left in dispenser cups	Dishes block cups or cups incorrectly loaded	Re-loading the dishes properly.

Trouble Shooting

Problem	Causes	Solution
The dishes are not drying	Improper loading	Load the dishwasher as suggested in the directions.
	Too little Rinse-aid	Increase the amount of rinse-aid and/or refill the rinse-aid dispenser.
	Dishes are removed too soon	Do not empty your dishwasher immediately after washing cycle has ended. Open the door slightly so that the steam can escape. Only begin unloading the dishwasher when the dishes are cool to the touch.
	Wrong program has been selected or a program without a drying cycle	In short programs the drying time is shorter or the program won't have a drying cycle at all. Choose a program with a long washing time.
	The crockery is made from non-stick material or plastic	Remove from dishwasher and leave to dry or dry with a dish cloth.
	Use of cutlery with a low-quality coating	Water drainage is more difficult with these items. Cutlery or dishes of this type are not suitable for washing in the dishwasher.

Error codes

Error codes	Meanings	Possible causes
E1	Water inlet problem/fault	Water intake is restricted or water pressure is too low
E3	Not reaching required temperature	Heating element fault
E4	Overflow	The dishwasher is leaking
Ed	PCB fault	Software or PCB board fault

Note: If overflow occurs, turn off the main water supply before calling a service engineer. If there is water in the base of the tub because of an overflow or small leak, the water should be removed before restarting the dishwasher.

Connection to the Mains Supply

WARNING- THIS APPLIANCE MUST BE EARTHED

This appliance is designed to operate from a mains supply of AC220V - 240V; 50Hz. Check that the voltage marked on the product corresponds with your supply voltage.

For UK use only – Plug fitting details (where applicable):

As the colours of the wires in the mains lead of this appliance may not correspond with the coloured markings identifying the terminals in your plug, proceed as follows:

The GREEN/YELLOW wire is the EARTH and must be connected to the terminal which is marked with the letter E or by the earth symbol or coloured GREEN or GREEN/YELLOW.

The BLUE wire is the NEUTRAL and must be connected to the terminal marked with the letter N or coloured BLACK.

The BROWN wire is the LIVE wire and must be connected to the terminal marked with the letter L or coloured RED.

Always ensure that the plug cord grip is fastened correctly.

If a 13A (BS1363) fused plug is used it must be fitted with a 13amp fuse conforming to BS1362 and be BSI or ASTA approved.

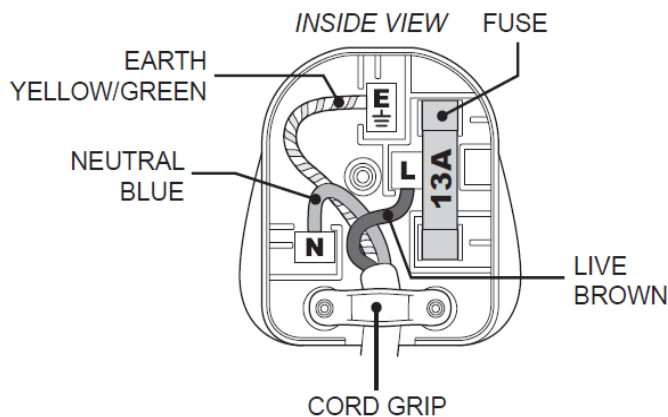

Guarantee

This product is guaranteed for 12 months from the date of the original purchase. If any defect arises due to faulty materials or workmanship you must contact Customer Services with the original proof of purchase so a replacement or refund can be arranged.

Refund or replacement is at the discretion of Customer Services.

The following conditions apply:

- Customer Services will require a valid proof of purchase at the point of replacement or refund.
- The product must be installed and used in accordance with the instructions contained in this instruction guide and any other instructions for use which has been supplied.
- It must be used for domestic purposes only and for its intended use.
- This guarantee does not cover wear and tear, damage, misuse or consumable parts.

This does not affect your statutory rights.

Technical Specification

Model number	RHTTDW6 (W) (B) (S)
Rated Voltage	220V – 240V ~ 50Hz
Capacity	6 place settings
External Dimensions(HxWxD)	438mm x 550mm x 500mm

Product Fiche

Model	RHTTDW6W/B/S
Rated capacity (number of place settings)*	6
Energy efficiency Index*	61.9
Energy efficiency class*	F**
Cleaning performance index*	1,125
Drying performance index*	1,065
Energy consumption in kWh [per cycle], based on the eco programme using cold water fill. Actual energy consumption will depend on how the appliance is used.	0,613
Water consumption in litres [per cycle], based on the eco program. Actual water consumption will depend on how the appliance is used and on the hardness of the water.	6.5
Program duration* (h:min)	3:50
Airborne acoustical noise emissions* (dB(A) re 1 pW)	52
Off-mode (W)	0.49
Delay start (W) (if applicable)	1,00
Type	Freestanding
Airborne acoustical noise emission class*	D**
Standby mode (W)	N/A
Networked standby (W) (if applicable)	N/A
Water pressure (flow pressure)	0.04-1.0 MPa = 0.4 – 10 bar
Rated input / frequency	220V-240V ~ 50Hz
Product Dimensions CMs (H x W x D)	(H)43.8 x (W)55 x (D)50

*for the eco program.

**if the product database automatically generates the definitive content of this cell the supplier shall not enter these data.

- Commission Regulation (EU) 2019/2022 of 1 October 2019 laying down eco design requirements for household dishwashers pursuant to Directive 2009/125/EC of the European Parliament and of the Council amending Commission Regulation (EC) No 1275/2008 and repealing Commission Regulation (EU) No 1016/2010 (see page 267 of this Official Journal).

Notes

Notes



Russell Hobbs

Made by Product Care Trading Limited under license from Spectrum Brands (UK) Limited. Product Care Trading Ltd, Unit 1, Green Bank Business Park, Swan Lane, Hindley Green, Wigan, WN2 4AY, United Kingdom

Product Care (Ireland) Ltd, Unit 3D North Point House, North Point Business Park, New Mallow Road, Cork, T23 AT2P, Ireland. Russell Hobbs is the registered trademark of Spectrum Brands (UK) Ltd.

**UK
CA**

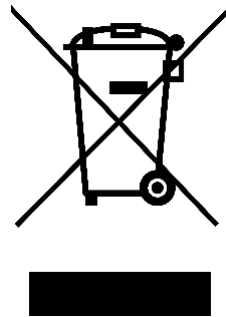

The 'wheellie bin' symbol is known as the 'Crossed-out wheellie bin Symbol'.

When this symbol is marked on a product/batteries, it means that the product/batteries should not be disposed of with your general household waste. Only discard electrical/electronic/battery items in separate collection schemes, which cater for the recovery and recycling of materials contained within. Your co-operation is vital to ensure the success of these schemes and for the protection of the environment. For your nearest disposal facility, visit www.recycle-more.co.uk or ask in store for details.

SEDEX – Connecting businesses and their global suppliers to share ethical data and enabling improvement in ethical performance. Visit www.sedex.org.uk for further information.

We reserve the right, due to possible changes to design, to alter the instruction manual without prior notice.

Revision 5.7