

SINGLE SIZE

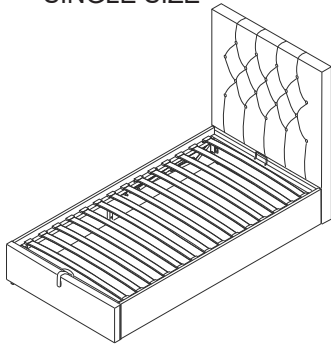

SMALL DOUBLE,
DOUBLE & KING SIZE

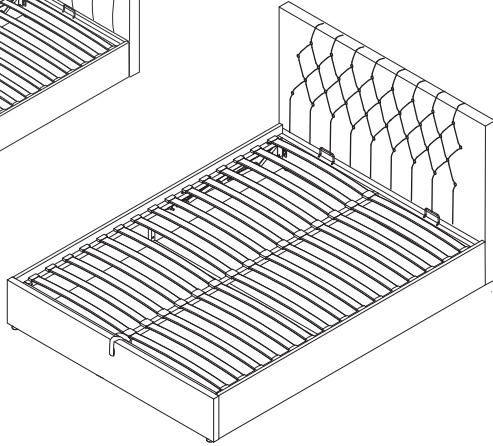

PLEASE READ this sheet prior to assembly to familiarise yourself with the various stages of construction. Carefully open the pack supplied and check the contents against the parts and fittings check list.

Do not destroy any of the packaging until you are certain that you have all the necessary parts for the assembly.

Please ensure that the packaging is disposed of in a safe environmentally friendly way.

CAUTION: There are small components used in the construction of this unit. These loose items should be kept away from young children during assembly, to avoid the danger of choking.

IMPORTANT: BEFORE STARTING TO ASSEMBLE THE BED - PLEASE READ THESE INSTRUCTIONS CAREFULLY.

Parts Identification

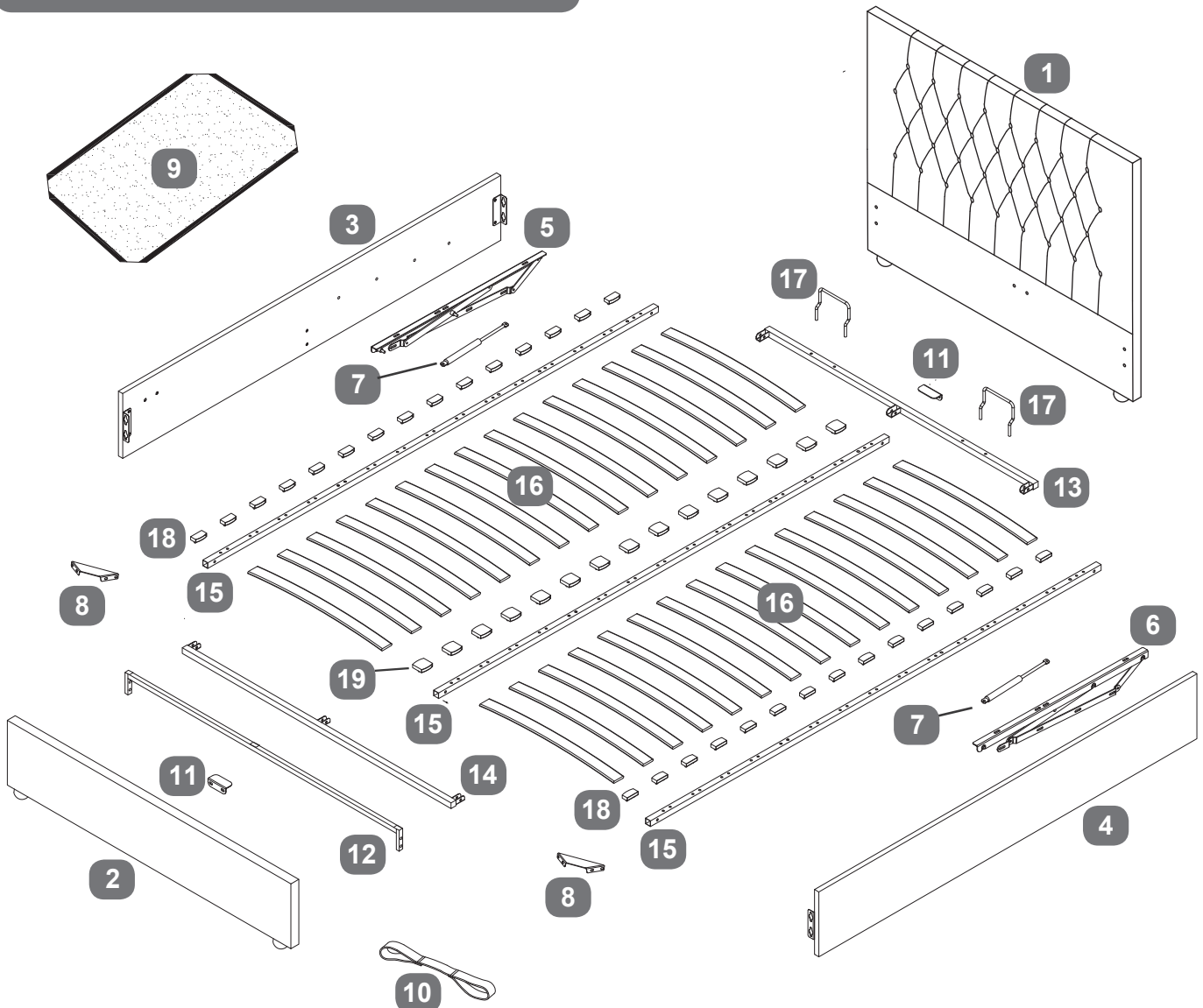







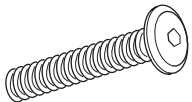

Parts Checklist

Ref.	Description	Qty	Ref.	Description	Qty
1	Headboard	1	11	Frame Support Bracket	2
2	Footboard	1	12	'U' Shape Cross Bar	1
3	Side Rail - LH	1	13	Cross Rail for Metal Slat Frame - Headend	1
4	Side Rail - RH	1	14	Cross Rail for Metal Slat Frame - Footend	1
5	Lift Mechanism - LH	1	15	Side Rail for Metal Slat Frame	Single/Small Double, Double or King 2/3
6	Lift Mechanism - RH	1	16	Bentwood Slats	Single/Small Double or Double/King 14/28/30
7	Gas Lift Pistons	2	17	Mattress Stopper	Single/Small Double, Double or King 1/2
8	Angle Corner Brackets	2	18	Single Plastic Caps	Single, Small Double or Double/King 28/30
9	Fabric Base Cover	1	19	Double Plastic Caps	Small Double or Double/King 14/15
10	Fabric Strap	1			

Fittings Checklist

HARDWARE NEEDED FOR BED ASSEMBLY

Code	Description	Qty	Code	Description	Qty
A	Big head bolts (M8x45mm) for assembling metal slat frame rails and fitting assembled metal slat frame to lift mechanisms (5&6). Also for fitting 'U' shaped cross bar (12) to side rails (3&4).	 Single x14 Small Double, Double & King x16	E	Flat washers for M8 bolts	 Single x10 Small Double, Double & King x12
B	Big head bolts (M8x30mm) for fitting gas lift mechanisms (5&6) to Side Rails and fitting Side Rails (3&4) to headboard and footboard (1&2)	 x16	F	Nuts for M8 bolts	 Single x14 Small Double, Double & King x16
C	Big Head Bolts (M8x16mm) for fitting frame support brackets (11) and corner brackets (8) to headboard and footboard (1&2)	 x12	G	Allen key for M8 bolts	 x1
D	Plastic spacers for lift mechanisms (5&6)	 x8	H	Spanner for M8 nuts	 x1

Care & Maintenance

In the unlikely event of missing or damaged parts, please contact your retailer. Please have this guide at hand quoting the part code reference numbers shown when requesting spare or replacement parts.

Warnings



NOTE: Before moving the slat frame, place the mattress on the slats. Without a mattress in place, the speed of movement is quick and may cause injury so great care is needed. Carefully lower the frame with the fabric hand-strap (10) ensuring the frame sides are aligned with the side panels; there should be an even gap on each side. If not aligned, check bed is still square (see Stage 4) and if it is, but gaps are still not even, re-align. Depending on the weight of the mattress, the rising speed will vary so be careful until you get used to the speed.

Always use the hand-strap to lift or lower the frame - keep fingers well away from the moving parts.

When fully assembled and with the mattress in position, please raise & lower the ottoman 4/5 times to ensure the gas pistons are fully lubricated.

General Hints & Tips



Two person assembly

Please retain your assembly instruction and tools provided for future use. Periodically check that all bolts are still tight.



Approximate time to assemble this product



Bed Assembly

Stage
1

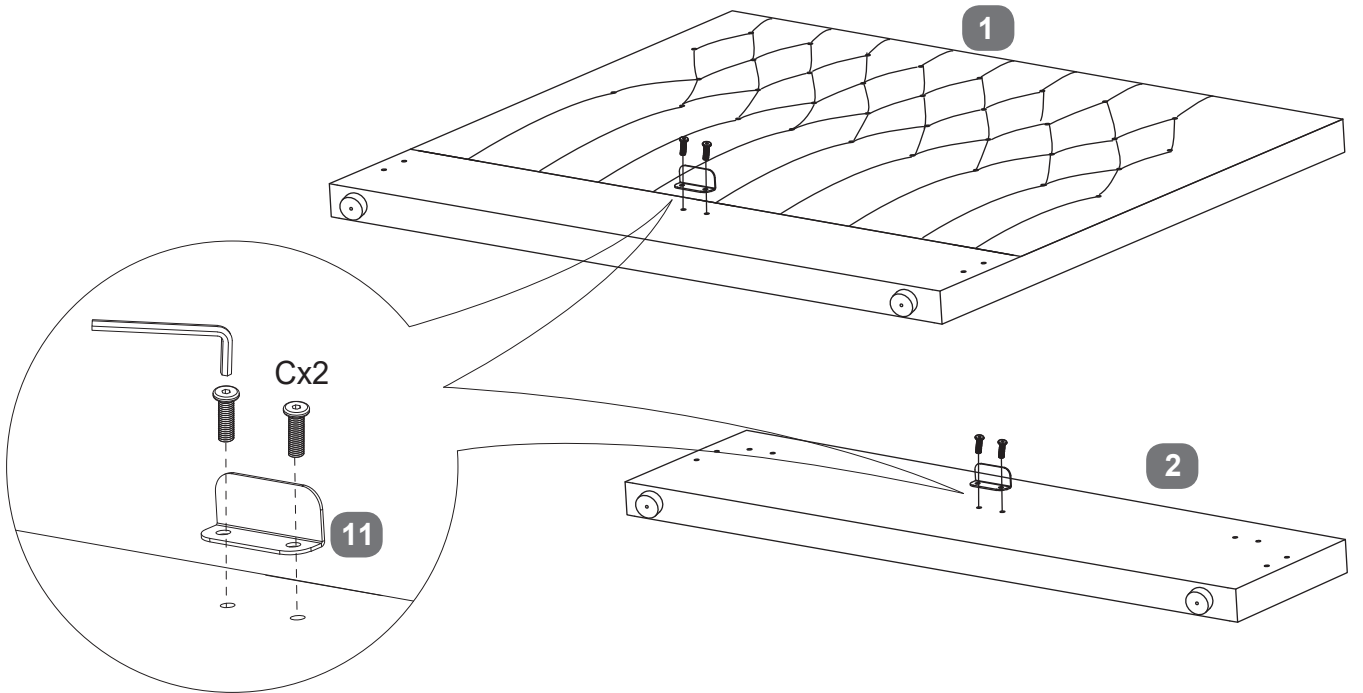
C  x4 G  x1

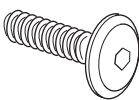
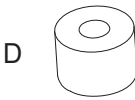

Stage
2

B  x8 D  x8 G  x1

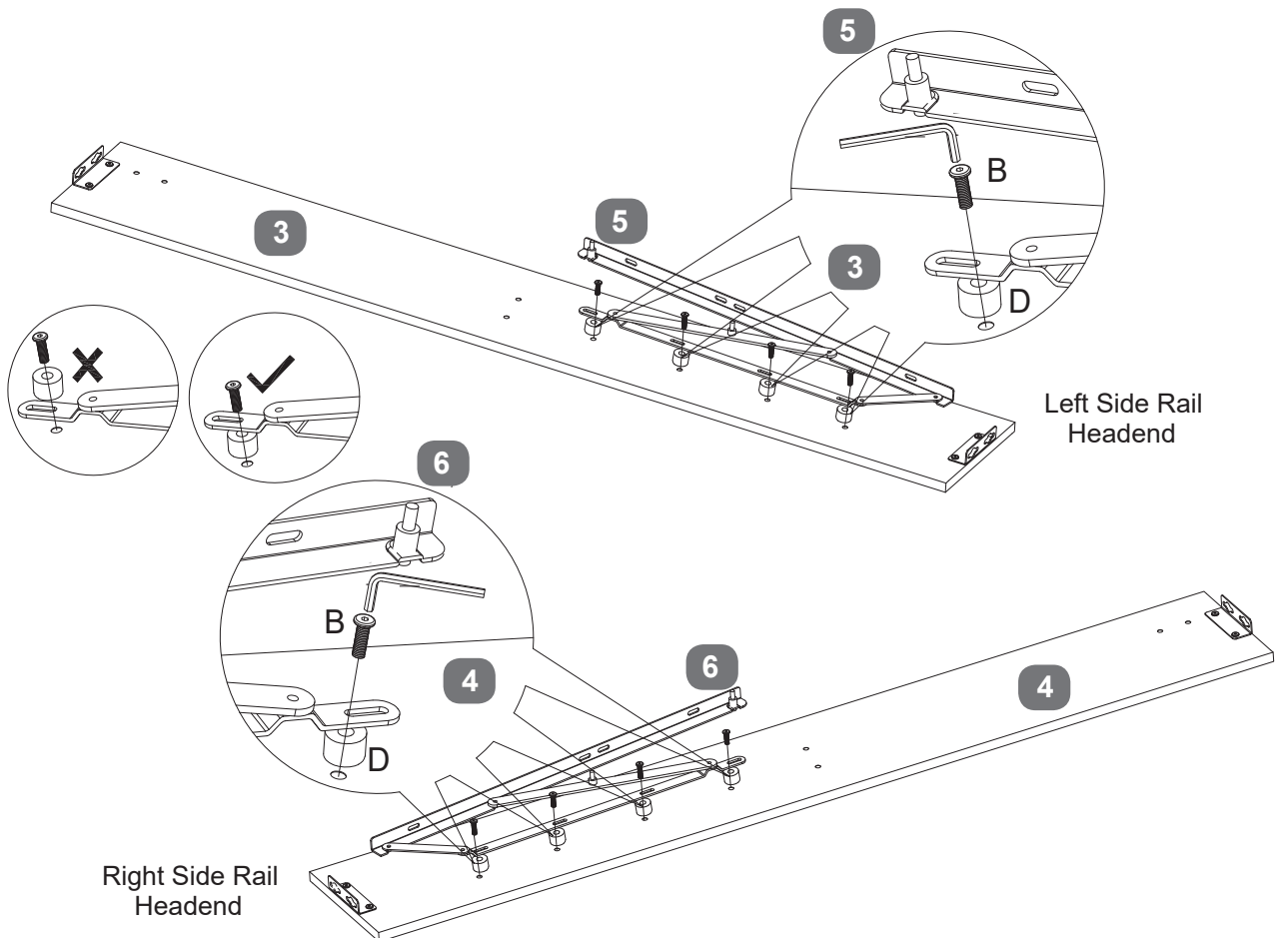



Bed Assembly

Stage
3

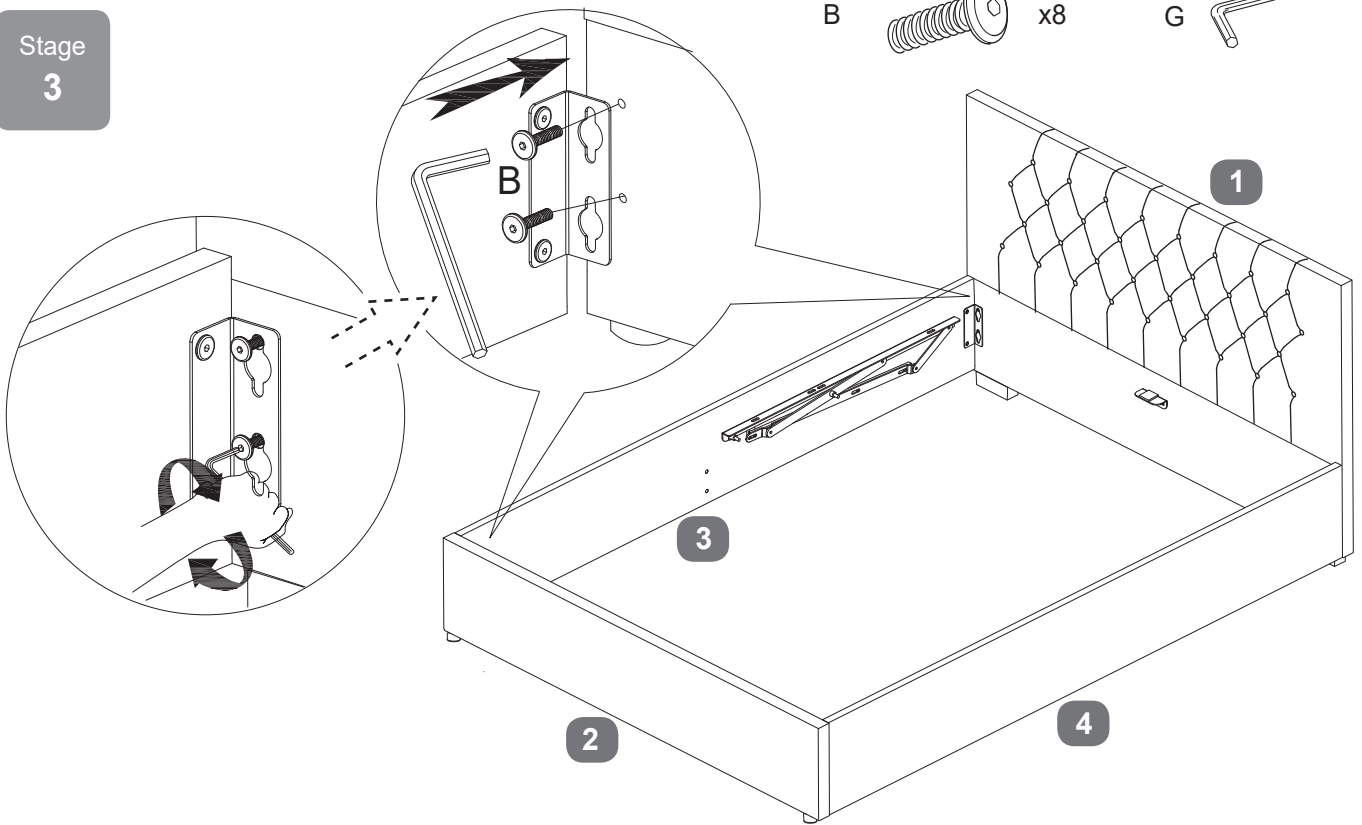
B  x8 G  x1

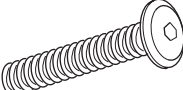

Stage
4

A  x4 C  x8 G  x1

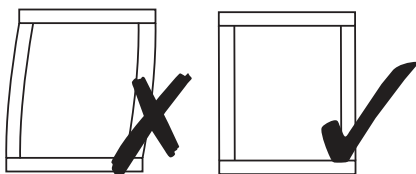
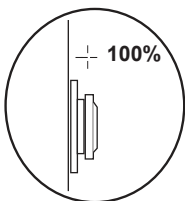
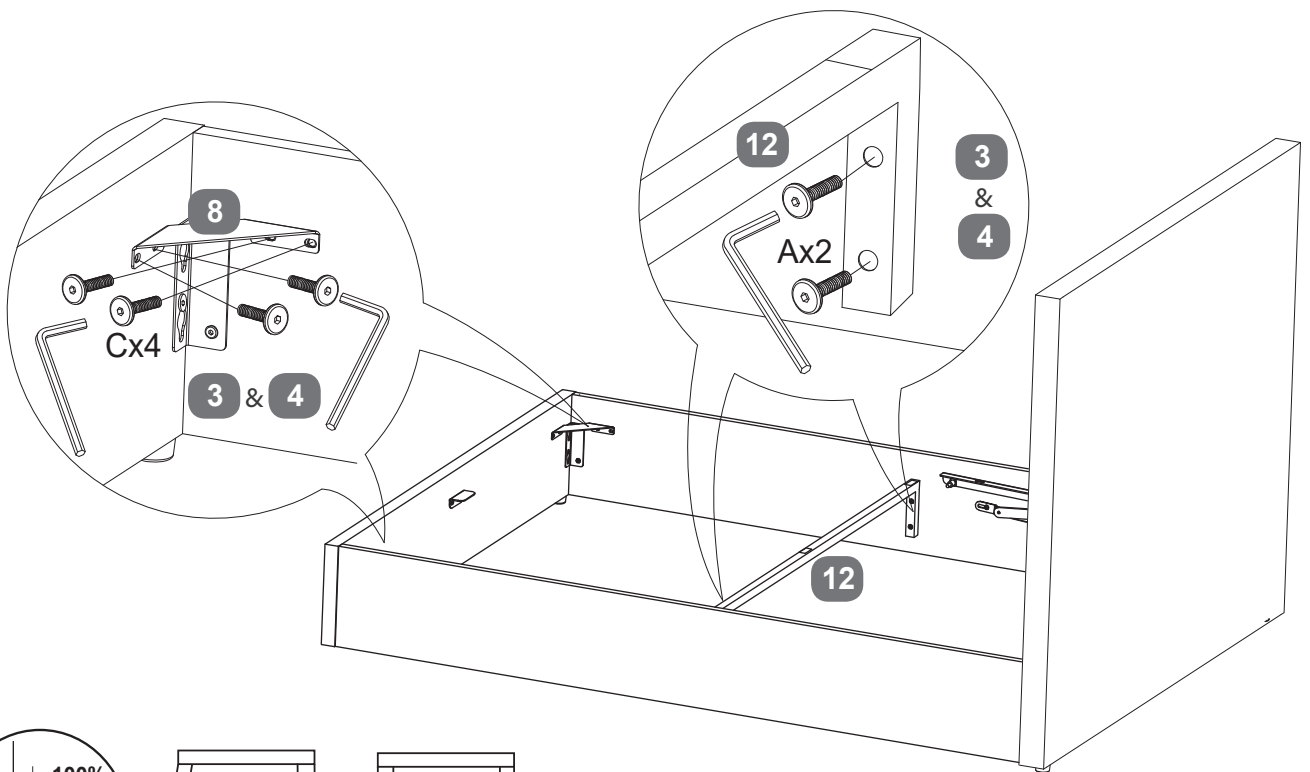

Bed Assembly

Stage
5

⚠ WARNING
CAREFULLY LIFT BOTH HEADBOARD
& FOOTBOARD AT THE SAME TIME,
DO NOT LET THE BED TWIST.

Lift and turn bed on its side and with assistant holding bed upright for safety, attach fabric base cover (9) to bottom of side-rails, headboard & footboard with the velcro tape. Make sure fabric is fixed evenly all round.

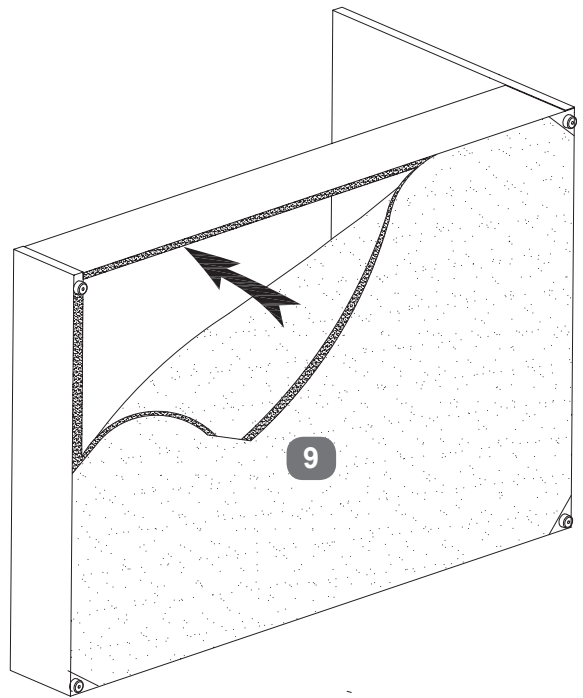

Stage
6a

For Single Size

This view is looking from underneath the slat frame

Please ensure that the eight holes are aligned as shown in the diagram.
The many slat holes in each long rail should be underneath touching the floor.

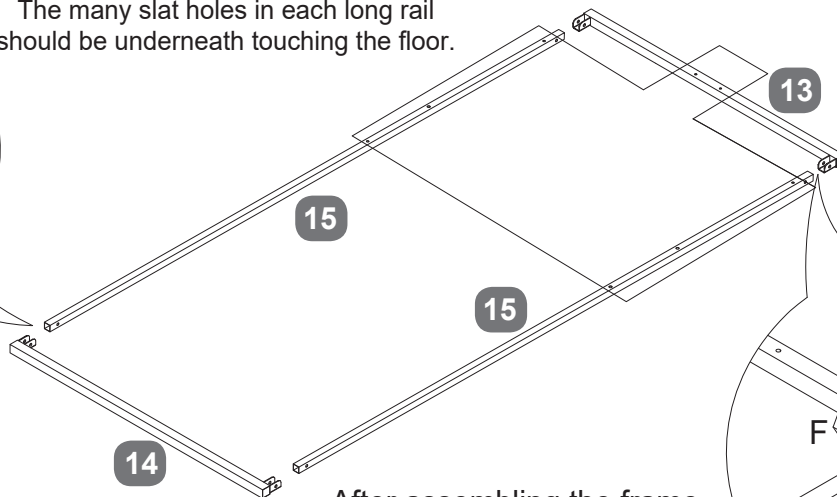
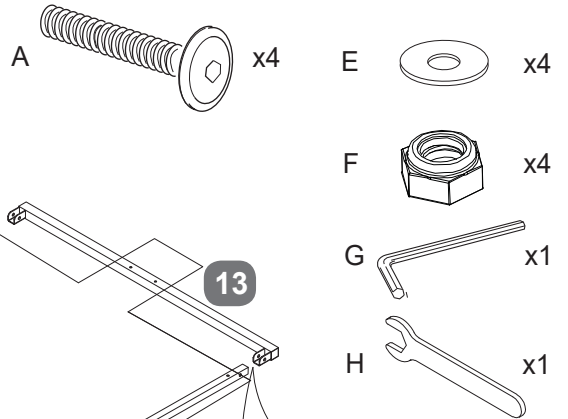
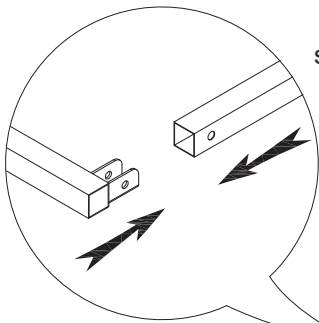

After assembling the frame, please turn it over, fit caps (16) to each slat and push into the holes as shown.

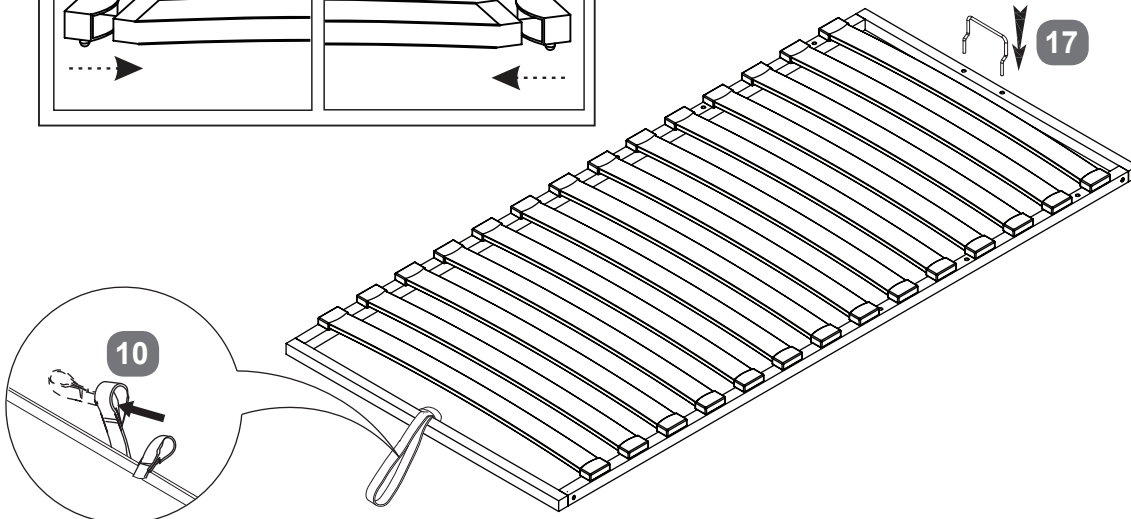
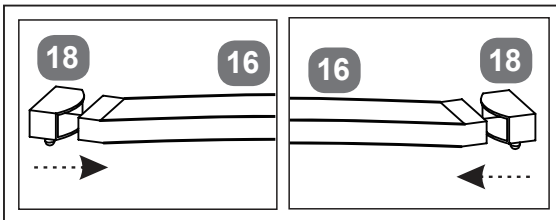





Bed Assembly

Stage
6b

For Small Double, Double and King Size

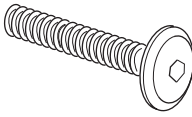
This view is looking from underneath the slat frame

Please ensure that the ten holes are aligned as shown in the diagram.
The many slat holes in each long rail should be underneath touching the floor.

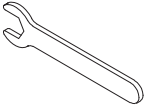
- A  x6
- E  x6
- F  x6
- G  x1
- H  x1

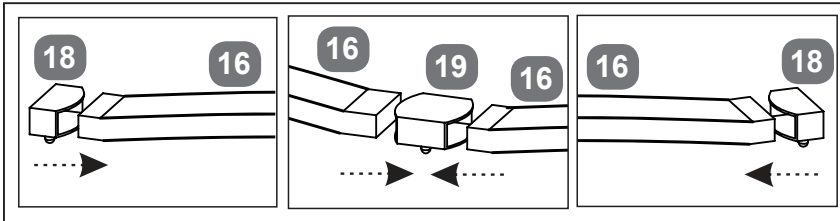
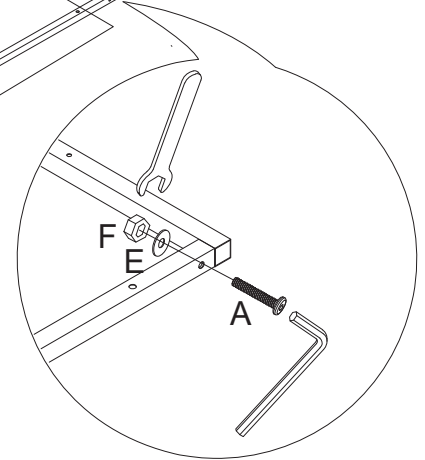
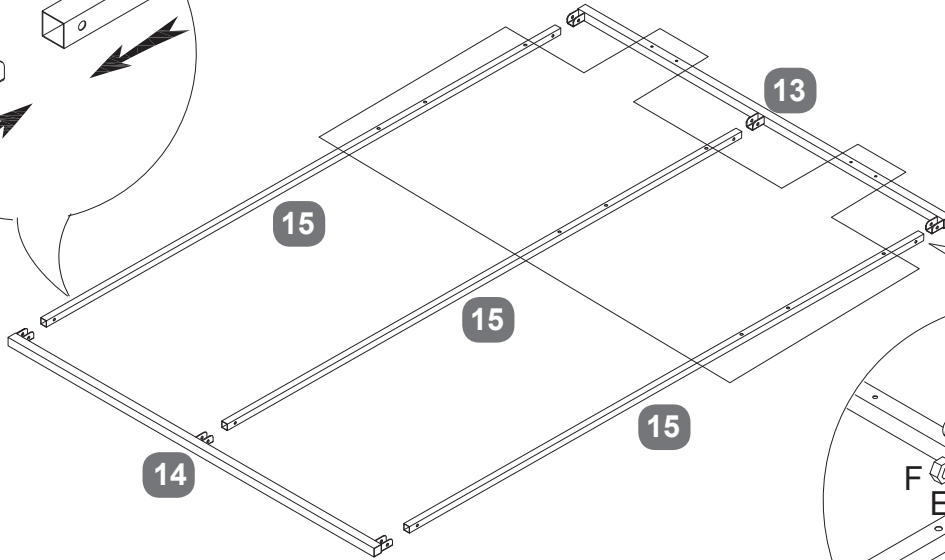
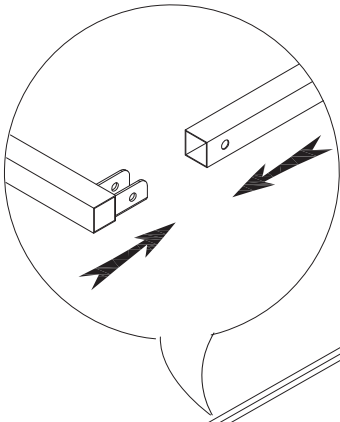

After assembling the frame, please turn it over, fit caps to each slat and push into the holes as shown.

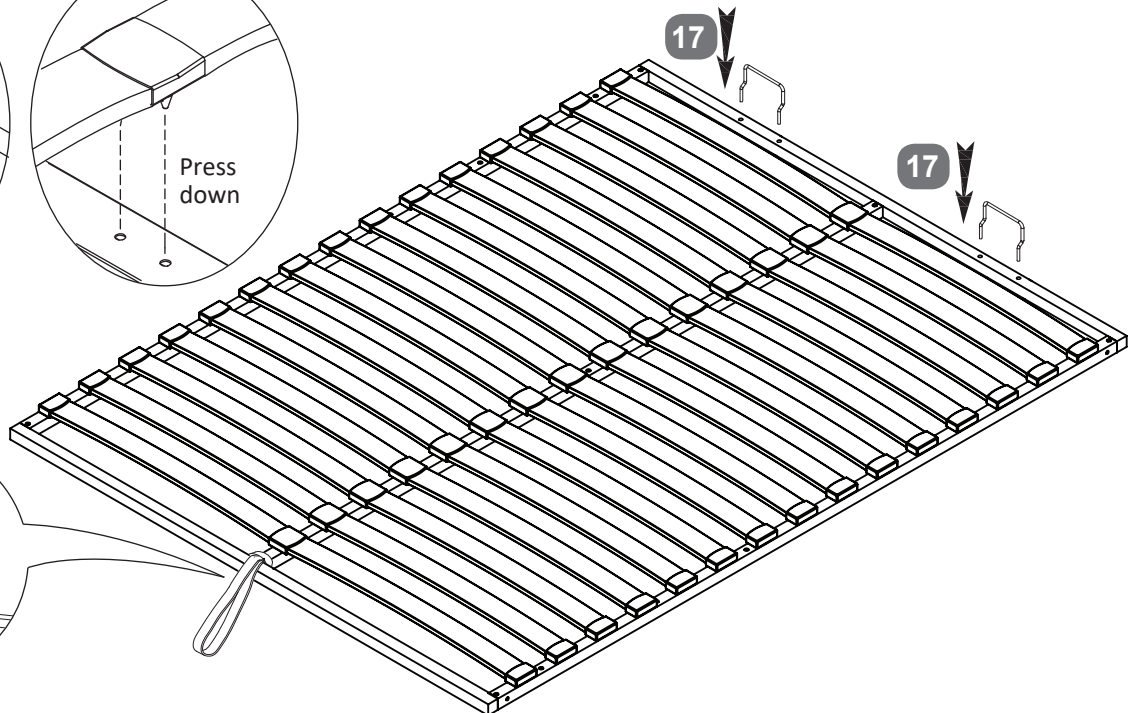
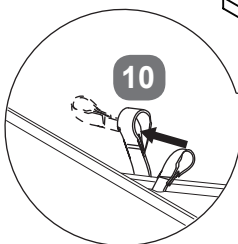
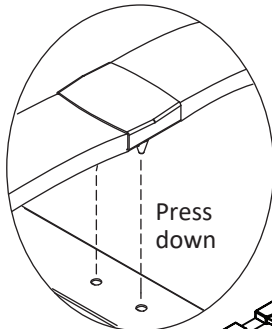
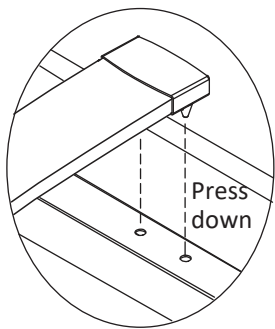

Bed Assembly

Stage
7

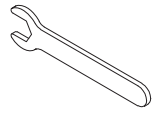

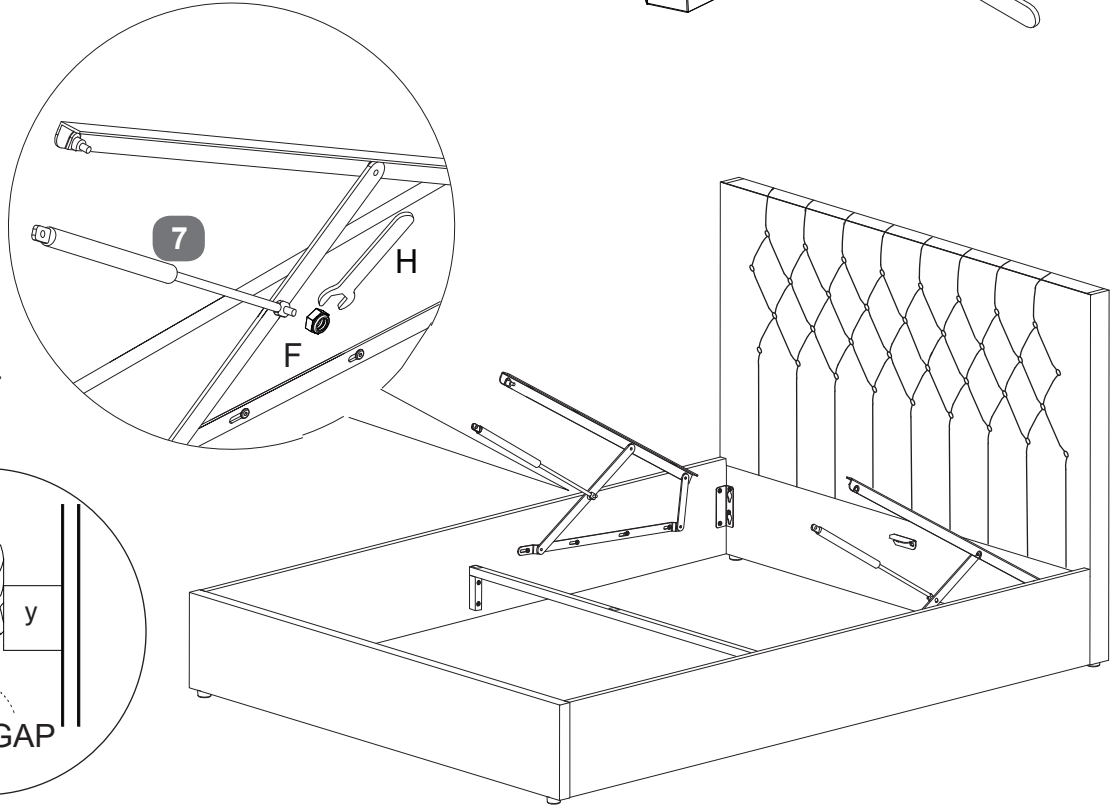
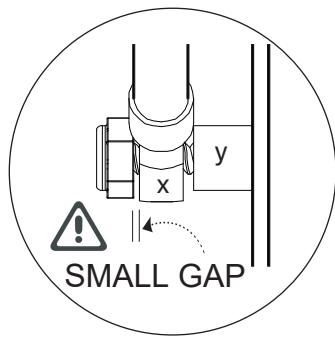

- F  x2
- H  x1

Slide gas-lift piston stem (x) onto the axle (y) then fit the flange lock-nut (F). Tighten nut with spanner (H) - do not over-tighten

A small gap must be left so stem can move freely - this is normal, see sketch below.

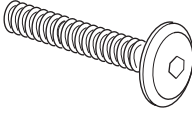

Stage
8

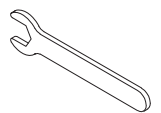
- A  x6
- E  x6
- F  x6
- G  x1
- H  x1

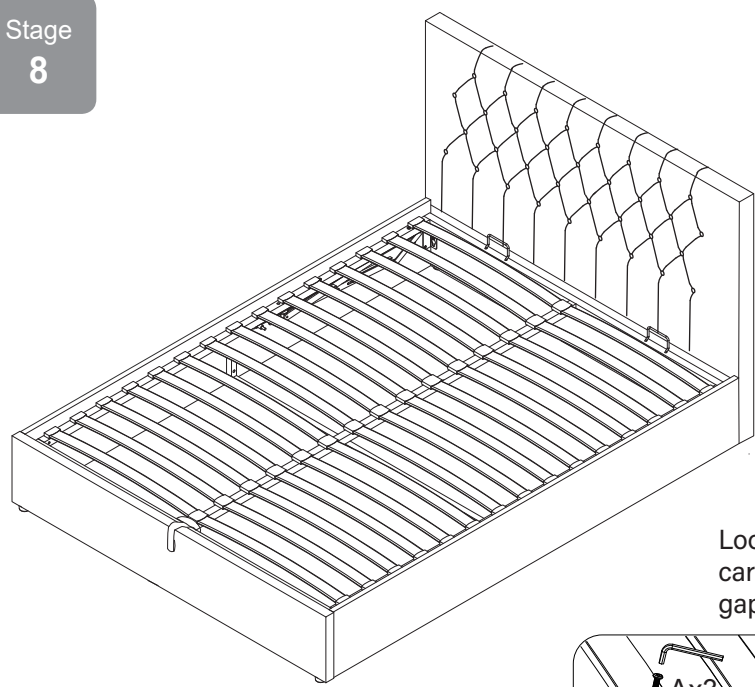

Loosely fit three bolt sets on each side (A), (E) & (F), carefully hold frame down and align so there even gaps at each side then tighten all bolts 100%

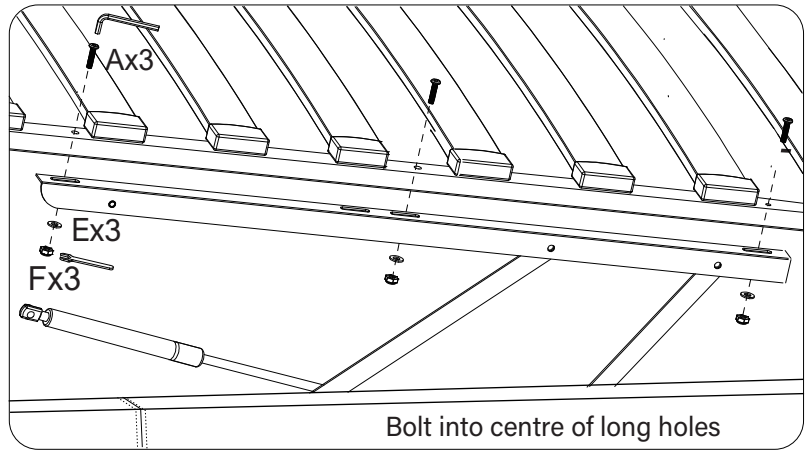

Bed Assembly

Stage
9

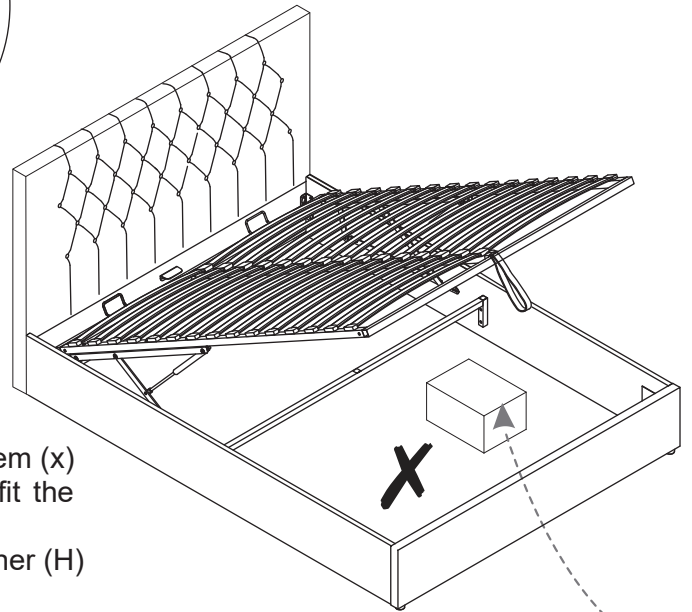
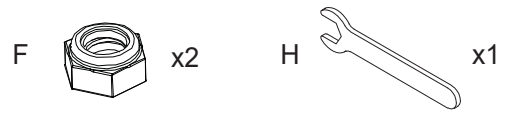
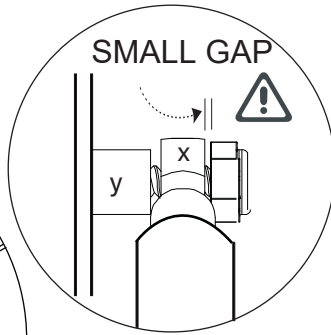
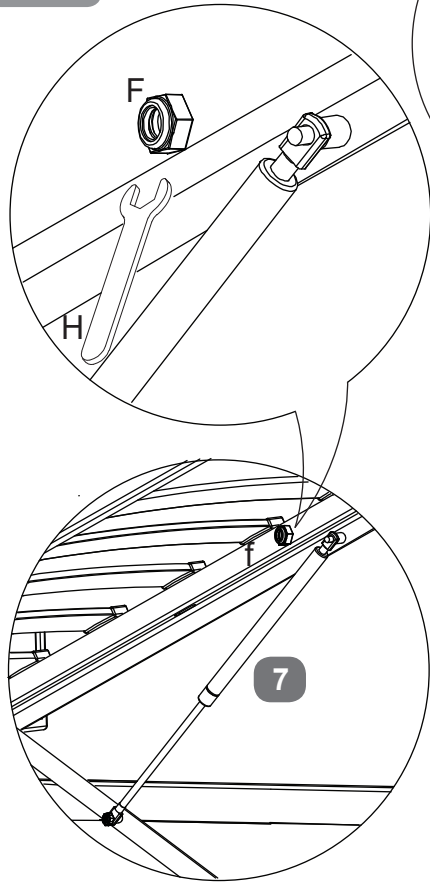

Slide gas-lift piston stem (x) onto the axle (y) then fit the flange lock-nut (F). Tighten nut with spanner (H) - do not over-tighten.

A small gap must be left so stem can move freely - this is normal, see sketch above.

Note: Be very careful what you store under the bed - the top of an item, like a suitcase or a box, must not touch the slats or they may be damaged.

Maximum storage height is 225mm.

Overall Dimensions (LWH cm)

Single: 205.5 x 99 x 136
 Small Double: 205.5 x 129 x 136
 Double: 205.5 x 144 x 136
 King: 215.5 x 159 x 136

Storage Dimensions (LWH cm)

Single: 193 x 92.5 x 22.5
 Small Double: 193 x 122.5 x 22.5
 Double: 193 x 137.5 x 22.5
 King: 203 x 152.5 x 22.5

Distance between slats (cm)

7.3

