

ASSEMBLY INSTRUCTION FOR OTO-45-3888-BW-60"X75"

Note:
 ■ Read instructions carefully.
 ■ Carefully identify each component especially those that are similar.
 ■ Separate and identify each component from the hardware pack and rest each one in its proper location before fastening.
 ■ Do not over tighten the screws or bolts when assembling.

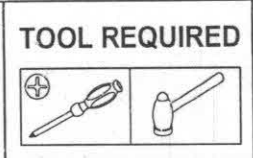

Step 1

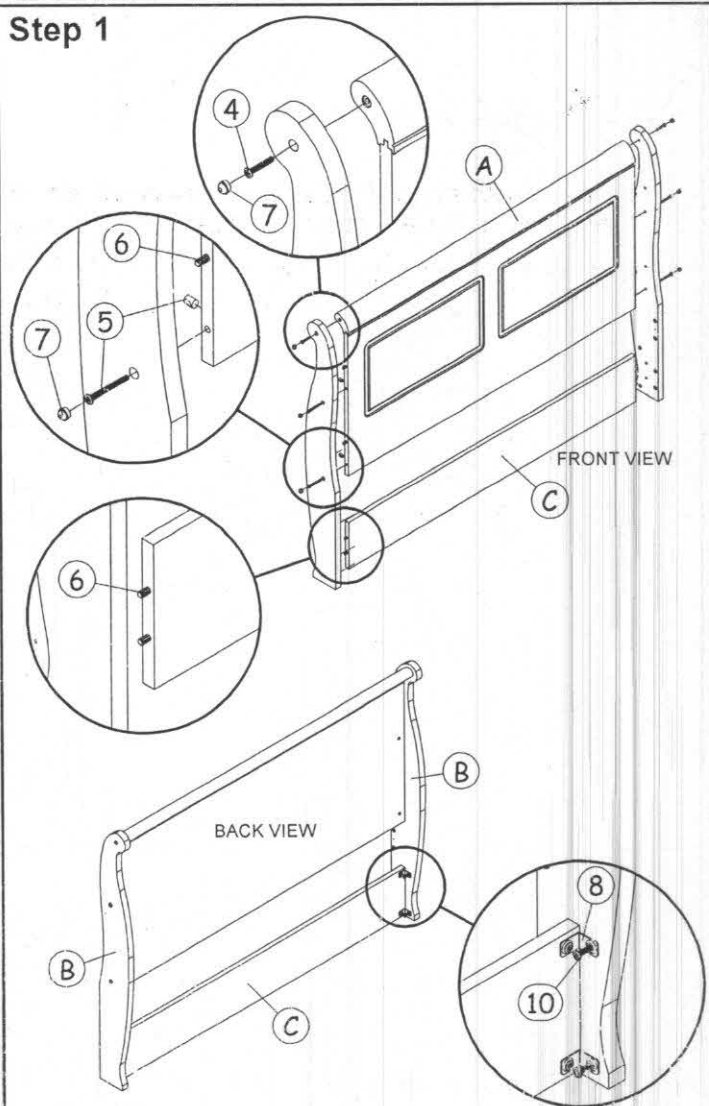

Fix the headboard frame panel 'A' and headboard back panel 'C' to the headboard wood post L/R 'B' with hardware parts as shown.

Step 3

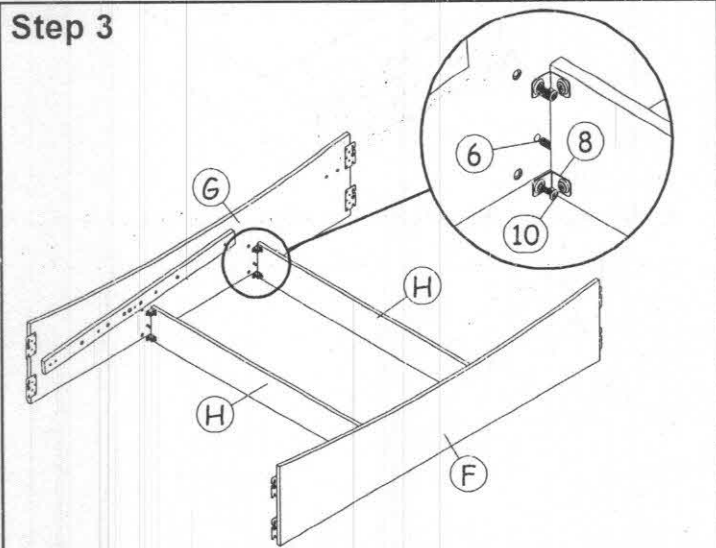

Assemble the left & right side rails to the center panel 'H' with L-bracket '8' and bolts '10' as shown.

Step 4

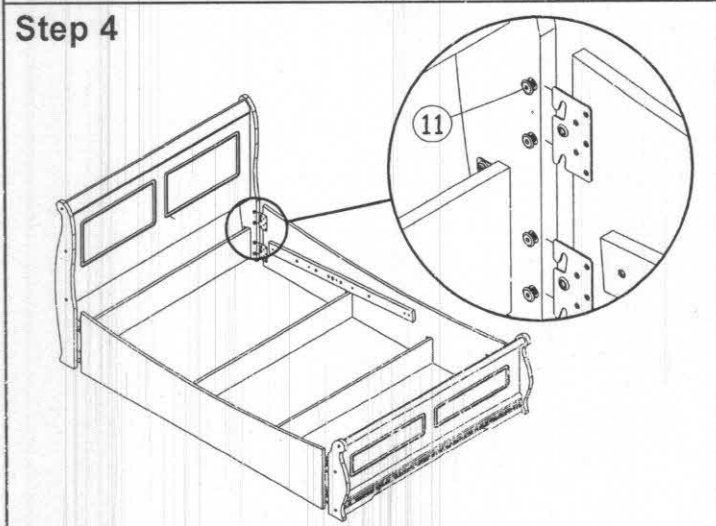

Attach the headboard frame and footboard to the side rails by using bolts '12' as shown.

Step 2

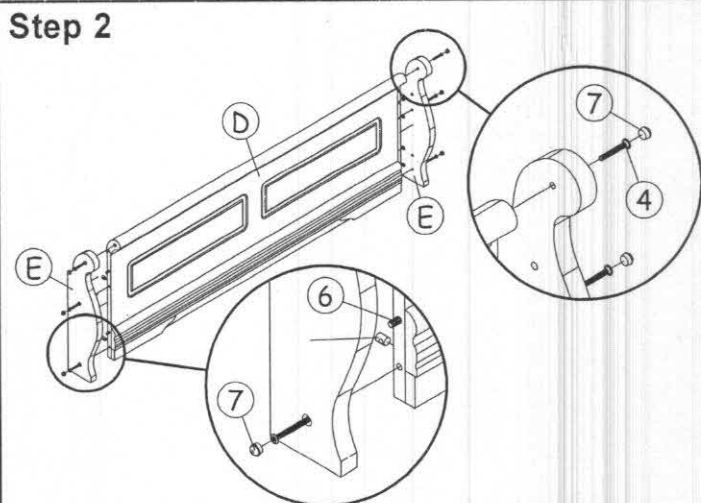

Fix the footboard frame panel 'D' to the footboard wood post L/R 'E' with hardware parts as shown.

Step 5

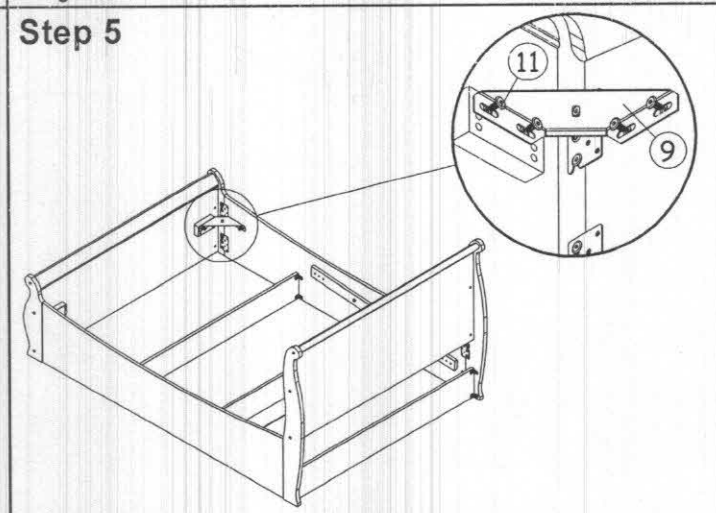

Fix the metal corner block '9' to the edge of footboard and side rails with bolts '11' as shown.

Please follow our assembly instruction procedure for easier assemble.

Step 6

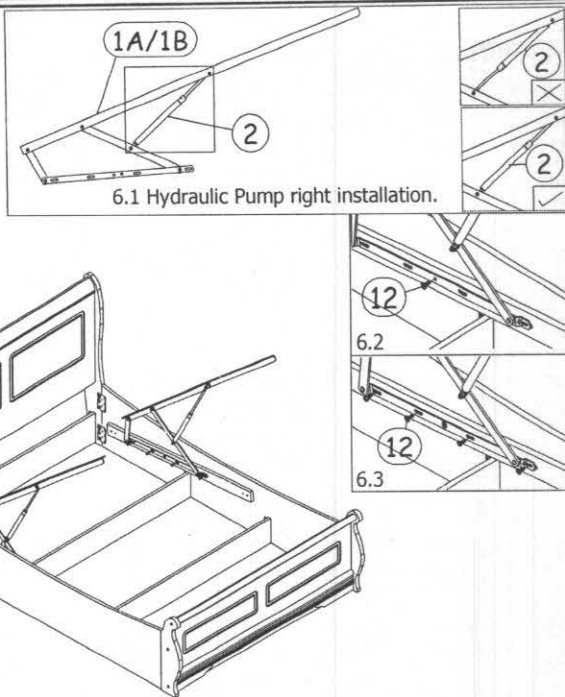

Firstly, fix the hydraulic pump to each hydraulic base as shown in diagram 6.1. Next, fix the left & right hydraulic support to the both side rails. Then, fix bolts '12' first as shown in diagram 6.2 and do not tighten yet. Finally, fix all bolts and tighten as shown in diagram 6.3.

Step 7

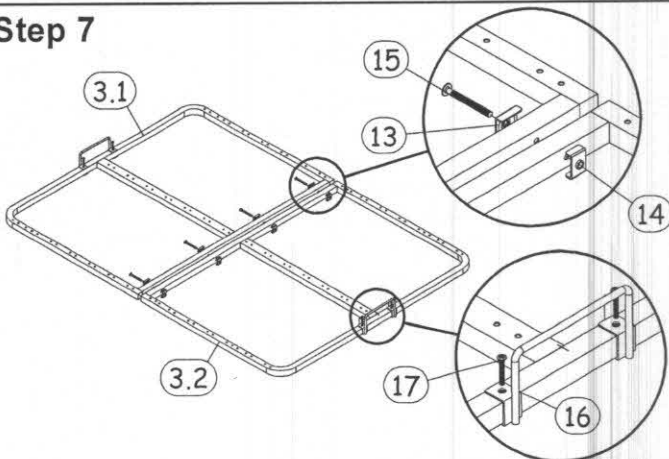

Assemble front '3.1' & back '3.2' frame bed base with hardware part '13' '14' and '15'. After that fix handles '16' to the bed base with bolts '17' as shown.

Step 8

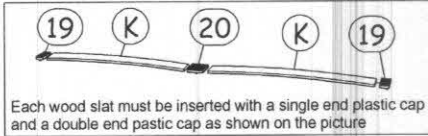

Insert the slats 'K' to hardware part '19' and '20' then press pin to the base making sure they are secure.

Step 9

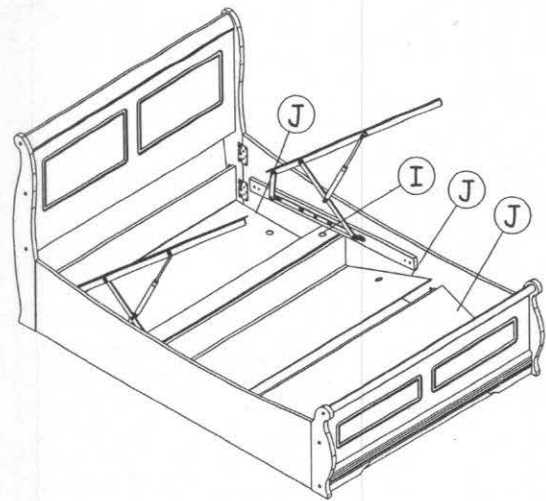

Insert the small base panel 'I' and large base panels 'J' as shown.

Step 10

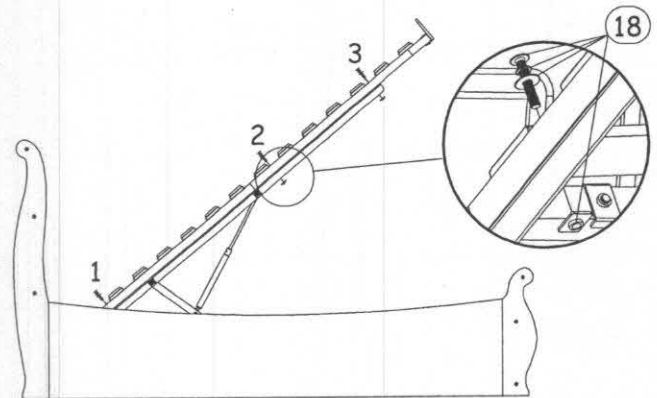

Assemble the bed base on the right & left hydraulic frame and fix bolts starting from '1' to '3' as shown. Important note : Do not tighten the bolts yet!



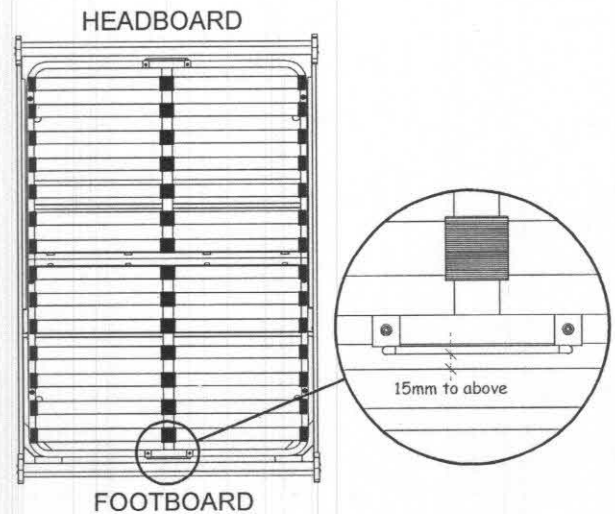



Step 11

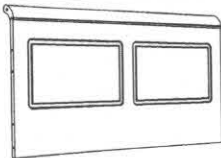
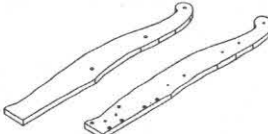

Adjust the bed base, make sure distance with the front footboard approximately 15mm to above gap as shown. Important note : Fully tighten all bolts & screws when assembly is complete.

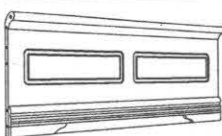
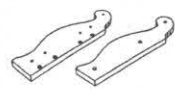
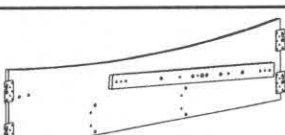
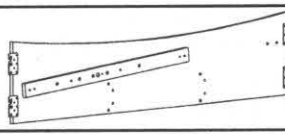
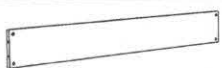
Please follow our assembly instruction procedure for easier assemble.

PARTS & HARDWARE LIST FOR OTO-45-3888-BW-60"X75"

PART LIST			NO.	ITEM	QTY.
NO.	ITEM	QTY.			
A	 HEADBOARD FRAME PANEL	1 PC	3	1. BED BASE (B) (1 X HOLE MOUNTING)	1 PC
				2. BED BASE (F) (2 X HOLE MOUNTING)	1 PC
B	 HEADBOARD WOOD POST L/R	2 PCS	4	JCBC BOLT M6 X 35MM	4 PCS
			5	JCBC BOLT M6 X 60MM & BARREL NUT	8 PCS
C	 HEADBOARD BACK PANEL	1 PC	6	WOOD DOWEL 8 x 30MM	20 PCS
D	 FOOTBOARD FRAME PANEL	1 PC	7	WOOD KNOB	12 PCS
E	 FOOTBOARD WOOD POST L/R	2 PCS	8	L-BRACKET 30X30	12 PCD
			9	ML-CB (METAL CORNER BLOCK)	2 PCS
F	 SIDE RAIL (L)	1 PC	10	JCBC BOLT M6 x 15MM	24 PCS
			11	JCBC BOLT M8 x 15MM	8 PCS
G	 SIDE RAIL (R)	1 PC	12	JCBC BOLT M8 x 20MM	26 PCS
			13	FLAT WASHER M8	4 PCS
H	 CENTER PANEL	2 PCS	14	BASE NUT	4 PCS
I	 SMALL BASE PANEL	1 PC	15	JCBC BOLT M8 x 75mm	4 PCS
J	 BIG BASE PANEL	3 PCS	16	BASE HANDLE	2 PCS
K	 WOOD SLAT	28 PCS	17	JCBC BOLT M6 x 40MM	4 PCS
			18	M8 x 45MM JCBB BOLT c/w NUT BRACKET, SPRING & FLAT WASHER	6 PCS
			19	SINGLE END PLASTIC CAP	28 PCS
			20	DOUBLE END PLASTIC CAP	14 PCS
			21	ALLEN KEY - M6	1 PC
			22	ALLEN KEY - M8	1 PC
			23	M12.8 SPANAR	1 PC
HARDWARE LIST					
NO.	ITEM	QTY			
1	1- HYDRAULIC BASE SUPPORT (L) c/w PUMP STOPPER	1 PC			
	2- HYDRAULIC BASE SUPPORT (R)	1 PC			
2	HYDRAULIC PUMP	2 PCS			
			CAUTION : KEEP ALL HARDWARE PARTS OUT OF REACH OF CHILDREN		

Please follow our assembly instruction procedure for easier assemble.

" IMPORTANT NOTE "

WHEN THE BED IS BUILT AND THE MATTRESS FRAME IS AT 45 DEGREE
PLEASE PLACE THE MATTRESS ON THE BED.

PLEASE NOTE THAT THE WEIGHT OF THE MATTRESS IS REQUIRED TO
HELP CLOSE THE BED.

TO LOWER THE SLEEPING PLATFORM STAND AT THE FOOT END OF THE
BED AND PUSH SHARPLY
DOWNWARDS USING BOTH HANDS.

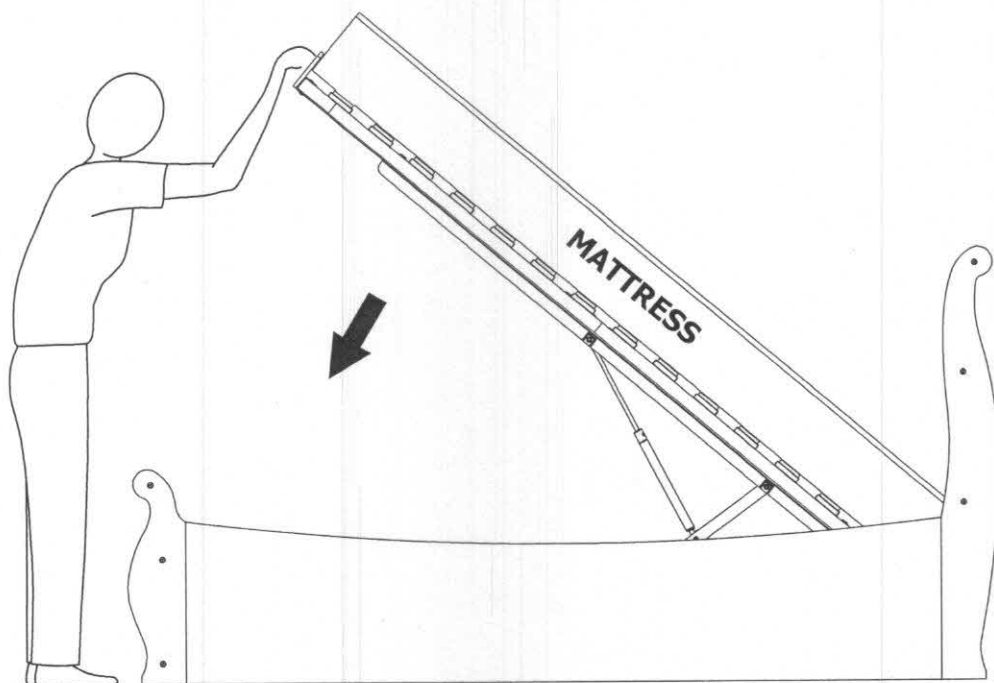

CAUTION :

PLEASE USE HYDRAULIC PUMP STOPPER FOR SAFETY PURPOSE.

