

Important Information

When installing your skylight, please ensure it is fitted with the correct fall to allow water to run off the glazing. **The recommended gradient is 80mm for every 1000mm to run in addition with the fall of your roof.** If you have any concerns before you apply the silicone to the skylight, we advise a simple water test that can be carried out by pouring water on the highest point of the skylight and monitor for any pooling as the water runs away. **The failure to use Low Modulus Silicone will void your warranty.**

1 MEASURING YOUR ROOFLIGHT

Firstly, measure the area you wish to site your skylight and ensure the internal dimensions are correct with skylight you have purchased

The size we provide is the **internal visible glass size** and this should exactly match your **structural opening size**.

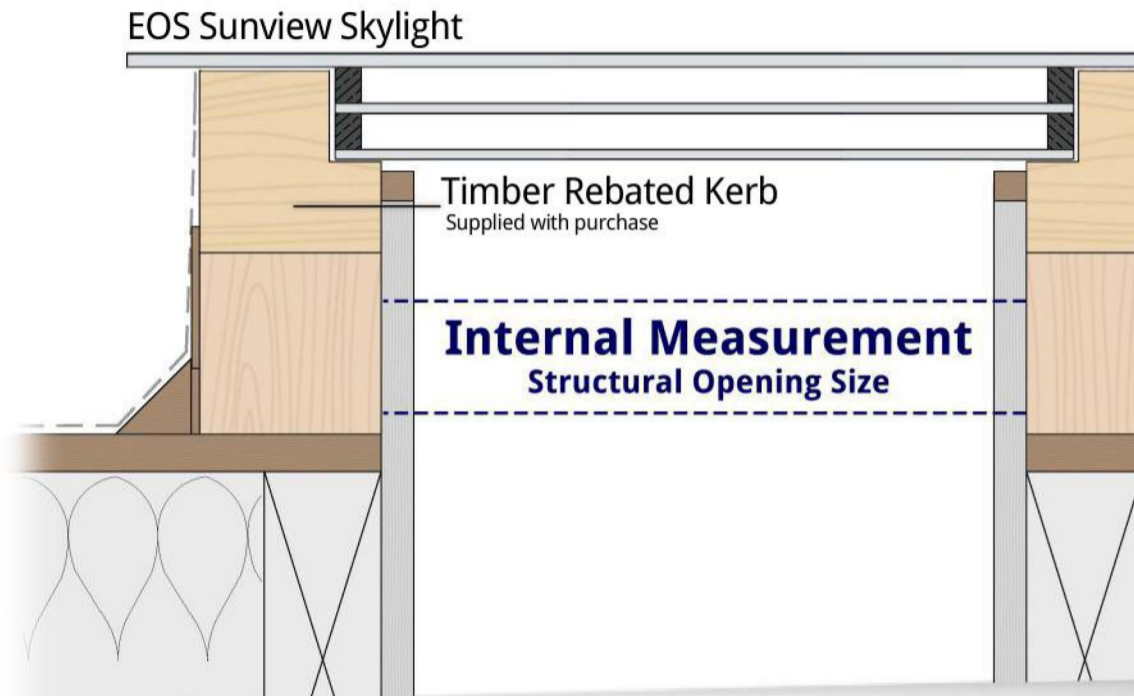

2 BUILDING YOUR UPSTAND

The *customer built upstand* sits below our Easy Fit Rebated Kerb.

The **upstand** should be constructed with timber and line up with the structural opening size. It should have a pitch if the fall of the roof is below our recommended gradient (see Step 3).

Once you have trimmed the joist to the correct structural size and have fitted your roofing board, construct a timber **upstand** that measures **70MM (W) x 70MM (H)** and secure to roof using **4" No.12 screws**.



3 FALL FOR WATER RUN OFF

When installing your skylight - you must ensure it is fitted with enough fall to prevent pooling. **A water test should be carried out before sealing the skylight into place by replicating rainfall on the highest point of the skylight and looking for any pooling as the water runs away.** If pooling occurs, a higher fall in the upstand should be created.

5° Pitch / 1" in 12" / 80mm in 1000mm.

Recommended angled pitch (including the run of the roof): 5 degree pitch / 1" in 12" / 80mm in 1000mm.

4

FIXING YOUR KERB

Measure out your fixing points on the provided Easy Fit Kerb. We recommend a fixing for every 400MM. Drill and countersink your fixing points. **The top of the screw must not protrude the top of the kerb.**

Secure your Easy Fit Kerb to your upstand with your chosen fixing at the predrilled intervals, ensuring the head of the screw does not protrude the rebated kerb.

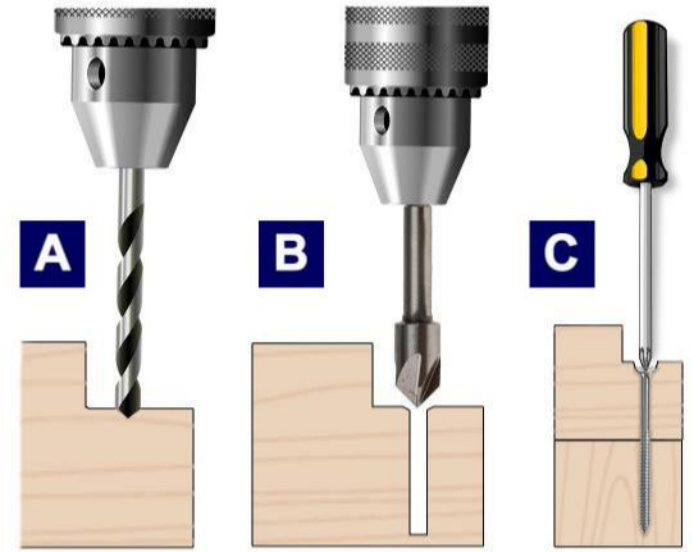

Roof covering ends here.

Use **either felt, lead or fibreglass**

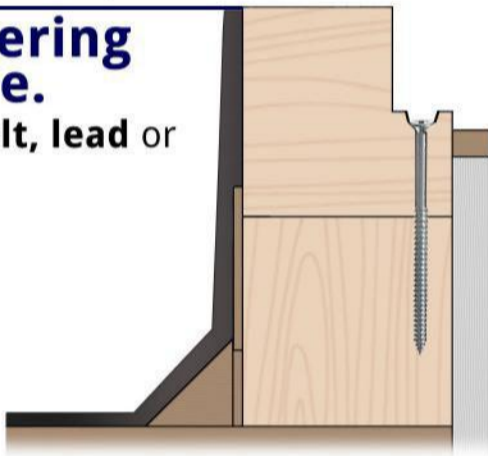

5

ROOF COVERING

Proceed to apply your roof covering so it fully encapsulates the kerb, joist and upstand. We recommend the use of felt, lead or fibreglass. **The roof covering must not lap over the top of the kerb.**

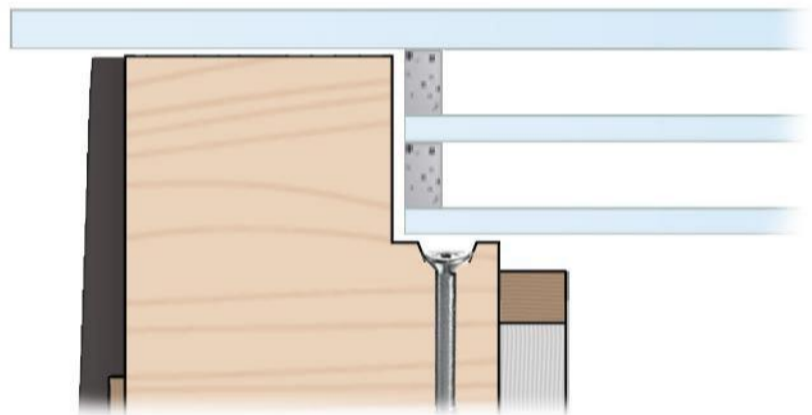

6

POSITION YOUR SKYLIGHT INTO PLACE

Position the skylight glazing into the Easy Fit Kerb, ensuring the step of the glazing is set inside the rebate of the Easy Fit Kerb. This may require extra persons depending on the skylight size.

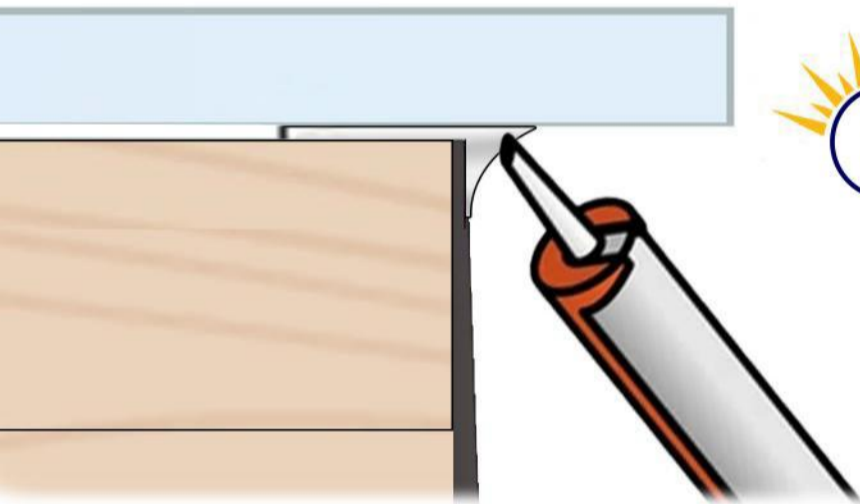

7

SEAL PERIMETER WITH SILICONE

The next step is to silicone seal your unit. Using good quality, weather-resistant low modulus sealant, apply a line of silicone around the perimeter between the underside of the glass border and the top edge of the roof covering. See *warranty document for silicone product recommendations.*

8

THE PERFECT SEAL

The silicone should leave a perfect seal between the glass unit and the roof covering, with no gaps. Allow to dry.



9

IMPORTANT NOTE WHEN ADDING WALL COVERING (TRIM)

For the internal wall covering, we recommend plasterboard with a trim at the top. **You must leave a 5mm gap between the top of the trim and the bottom of the glass.**