



## HC1100 and GN1100

# Near-boiling hot water taps

99°C water ready when you need it.



### Features:

The HC1100 and the GN1100 are perfect additions to any kitchen. The GN1100 dispenses near-boiling hot water at the touch of a lever and the HC1100 has the added benefit of providing cold filtered water.

- Modern contemporary design
- Elegant swivel spout
- Produces approximately 100 cups of near-boiling hot water per hour
- Dispenses up to 99°C hot and cold filtered water
- Adjustable digital temperature dial
- Compact and convenient
- Gentle touch dispenser
- Hot lever automatically shuts off
- Two year full warranty
- Unit not for commercial/industrial use

### Specification:

- Capacity: 2.5 Litre Stainless Steel tank dispenses approximately 100 cups of up to 99°C water per hour
- Required hole diameter: 35mm-38mm (HC1100) 32mm-38mm (GN1100)
- Required supply pressure: 172-862 kPa (1.7-8.6 bar) (25-125 psi)
- Available in 220-240 Volt A.C. and 115-120 Volt A.C. versions

### Technical diagram:

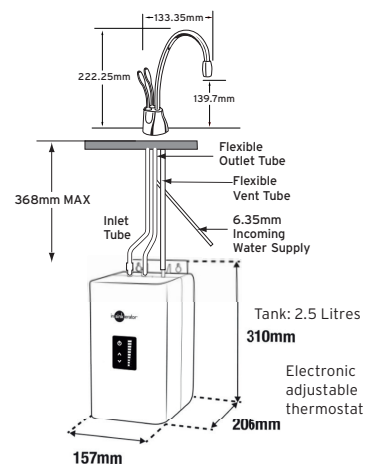

All InSinkErator® hot water systems are WRAS approved for your reassurance.

# Near-boiling hot water taps

## Instant 99°C water ready when you need it.

Once you have one, you'll wonder how you ever did without it. No kettles, no leads, no clutter, no fuss... up to 99°C near-boiling hot and cold filtered water at the push of a lever. With their contemporary designs, InSinkErator® models don't just bring style to the kitchen; they bring a level of convenience that fits today's busy lifestyles.

They also help you do your bit for the environment. Because you only heat as much water as you need, the taps are energy efficient and economical... saving you money every time they're used.



### Food and drink:

- Make tea, coffee and other hot drinks
- Prepare pasta and rice
- Blanche vegetables
- Create gravies, sauces and soups
- Thaw frozen food and warm ice cream scoops
- Re-hydrate dried food
- Clean fruit and vegetables

### Practical uses:

- Washing up
- Remove lids from jars
- Clean wax from candle holders
- Remove labels from containers for recycling
- Add extra shine to silver
- Fill hot water bottles

### Baby care:

- Warm bottles and food
- Clean without harsh chemicals



All InSinkErator® hot water systems are WRAS approved for your reassurance.

InSinkErator may make improvements and/or changes in the specifications at any time, in its sole discretion, without notice or obligation and further reserves the right to change or discontinue models.