



# AB Doer 360™

## Core & More

Abdominals

Aerobics

Muscle Toning

Fat Burning

Massage



## Quick Start Guide







## ONE YEAR LIMITED WARRANTY

The AB Doer 360™ home gym is warranted, to the original owner, for one (1) year from the date of purchase against defects in material and workmanship under normal use and service. Should your AB Doer 360™ home gym prove defective within one (1) year from date of purchase, please contact customer service immediately at the number provided below.

Please package your AB Doer 360™ home gym carefully to avoid damage in transit. Under this warranty, the Supplier will repair or replace any unit found to be defective. This warranty is effective only if the product is purchased and operated in the USA. This warranty extends only to personal use and does not extend to any product that has been used in a manner for which it is not intended. There are no warranties other than that expressly set forth herein. This warranty is not transferable. This warranty gives you specific legal rights, and you may also have other rights which vary from state to state.

Supplier is not responsible or liable for indirect, special or consequential damages arising out of or in connection with the use or performance of the product or other damages with respect to any economic loss, loss of property, loss of revenues or profits, loss of enjoyment or use, costs of removal, installation, other consequential damages of whatsoever nature, failure to follow instructions or warnings in the owner's manual or use of the product in a manner for which it was not designed.

### THIS WARRANTY DOES NOT APPLY TO THE FOLLOWING:

1. Damage due to accident, misuse, abuse or vandalism.
2. Improper or inadequate maintenance.
3. Unauthorized modification.
4. Damage in return transit.
5. Normal wear of parts (wear and tear that occurs over time and with use) including chips, scratches, abrasions, discoloration or fading.
6. Repairs made by an unauthorized service technician.

TO OBTAIN SERVICE: The original purchaser should immediately contact our customer service representative at **866-498-9345** and depending on the extent of the service requested, the purchaser shall have the obligations and responsibility to:

- Pay for all service and parts not covered by the warranty.
- Prepay shipping and handling.
- Carefully package the product using adequate padding material to prevent damage in transit. The original container is ideal for this purpose.
- Include in the package: the owner's name, address, telephone number, and a detailed description of the problem.
- Provide proof of purchase, which includes date of purchase.
- Send via Insured\* Parcel Post or courier to: Supplier or otherwise as instructed by customer service.

FOR ANY INQUIRES, PLEASE CONTACT SUPPLIER'S CUSTOMER SERVICE AT THIS TOLL FREE NUMBER: **866-498-9345**

\*Supplier is NOT responsible for any non-insured items lost in transit

## THANK YOU

Hello Doer!

Thank You for making the commitment to benefit from our brand new AB Doer 360™ - the best AB Doer version ever built! You're going to be truly amazed at how effective this system is at helping you accomplish your goals of looking and feeling your best. Now our next mission is to make certain you achieve your goals and attain the results you're expecting in the fastest way possible, or what we call, 'Accelerated Results™'.

In this manual, on the DVD routines (where available), and our on-line resources (where available) you now have a unique access to a wide variety of educational, instructional, and motivational tools. The Doer Lifestyle is all about healthy living and becoming the ABsolute best you can!

We invented AB Doer 360™ to provide a multitude of benefits throughout your entire body which are centered in the midsection. This is called the "Core Region" of the body. It is also referred to as the "midsection" or "waistline." Your upper body rests on top of the midsection while the midsection then rests on top of the lower body. We believe that total body training is a must for overall strength, energy, muscle tone, and metabolism. The bonus is that you will also reduce excess fat from your abdominals and your entire body as a whole.

In just a few short weeks you will also be amazed at the improvements you'll experience in the flexibility and strength of your back muscles and spinal column. You'll also begin to feel more limber and coordinated, have better posture and stamina, and be less stressed with AB Doers' built-in rolling massage technology.

Please finish reading this manual and watch the explanations and demonstrations on the DVD routines (where available) before your begin. Then you will be ready to take the first step on your new journey on developing the new you! So without further delay, let's get started!

Every day, you can now say to yourself and to others: I'm a Doer™!

Let's Go!  
Thane Direct

Just sit and get ready to become super fit!



"Actual Product May Differ  
From Images Shown"

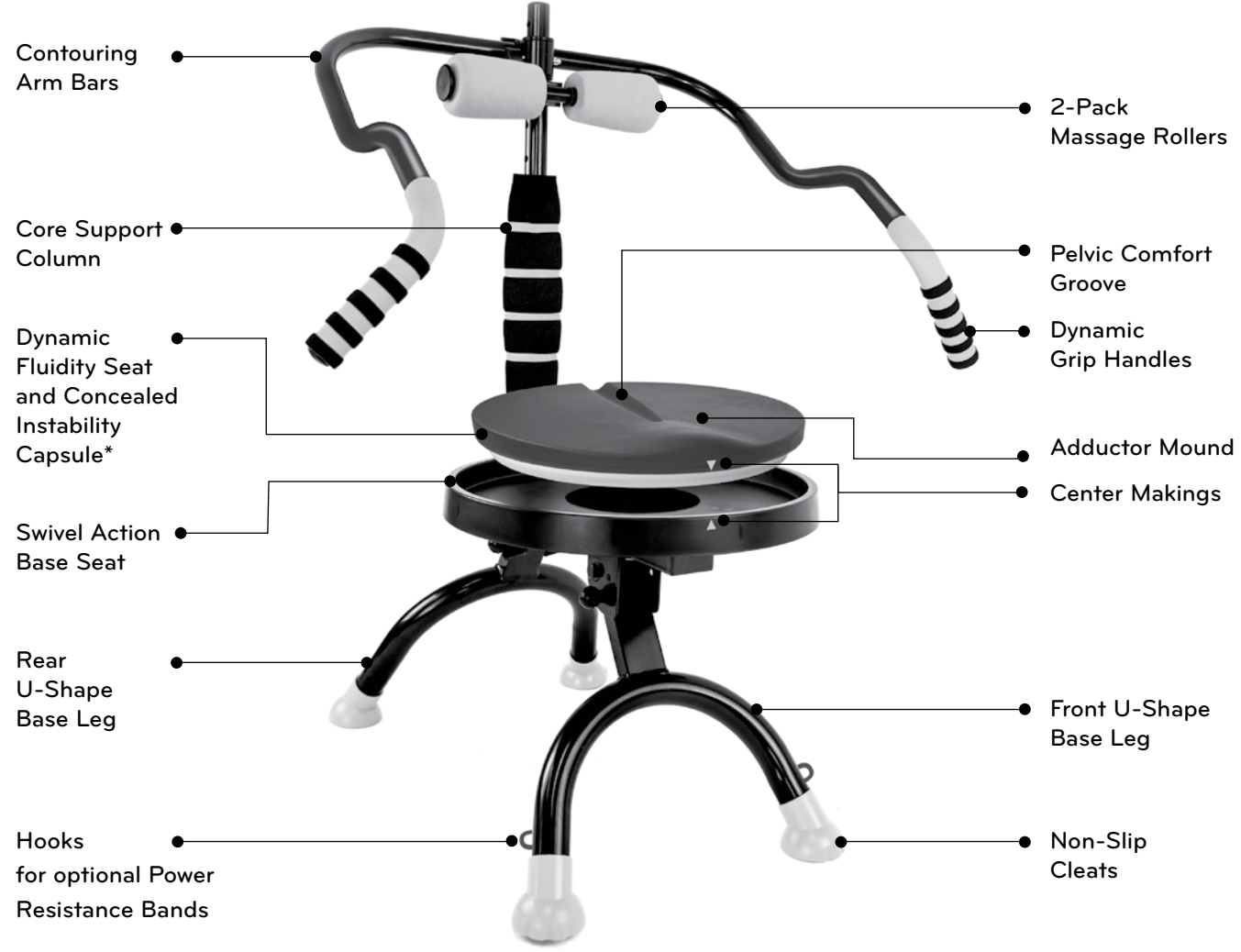

\* Removable Feature

# Motivational Calendar

## Track Your Results

Week 1	Week 2	Week 3	Week 4	Week 5	Week 6	Week 7	Week 8
Weight {kg/lbs}	Weight {kg/lbs}	Weight {kg/lbs}	Weight {kg/lbs}	Weight {kg/lbs}	Weight {kg/lbs}	Weight {kg/lbs}	Weight {kg/lbs}
Waist {inches/cm}	Waist {inches/cm}	Waist {inches/cm}	Waist {inches/cm}	Waist {inches/cm}	Waist {inches/cm}	Waist {inches/cm}	Waist {inches/cm}
Hip {inches/cm}	Hip {inches/cm}	Hip {inches/cm}	Hip {inches/cm}	Hip {inches/cm}	Hip {inches/cm}	Hip {inches/cm}	Hip {inches/cm}
Body Mass	Body Mass	Body Mass	Body Mass	Body Mass	Body Mass	Body Mass	Body Mass

SPICES; All Herbs & Seasonings	1 SERVING
Cinnamon	1 Tablespoon
Basil	1 Tablespoon
Black Pepper	1/8-1/4 Teaspoon
Cayenne	1/8-1/4 Teaspoon
Curry	1 Tablespoon
Garlic	1 Tablespoon
Oregano	1 Tablespoon
Parsley	1 Tablespoon
CONDIMENTS	
Catsup (low sodium)	2 Tablespoons
BBQ Sauce (No fat)	2 Tablespoons
Mustard	2 Tablespoons
Salsa	2 oz./56 gm
Vinegar	1-2 oz/29.5-59 ml
SNACKS	
Chips (No fat/sodium)	8 pieces
Rice cakes	1 piece
Popcorn	2 cups [popped, unsalted, unbuttered]

1 teaspoon = 5 ml / 1 tablespoon = 15 ml / 1 cup = 246 ml

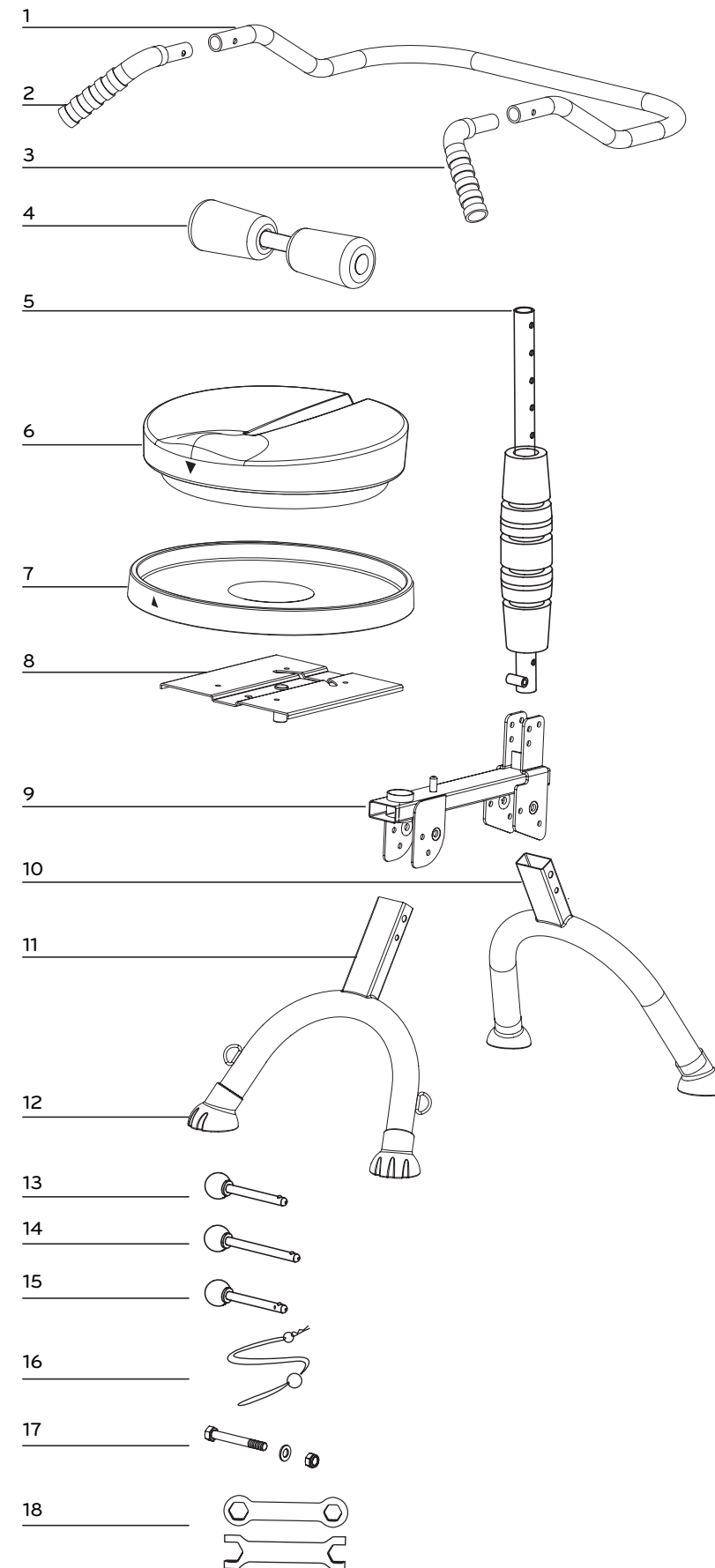

PARTS LIST

PART NUMBER	PART NAME
1	Contouring arm bars
2	Dynamic grip handle bar R
3	Dynamic grip handle bar L
4	2-Pack massage roller
5	Core support column
6	Dynamic Fluidity Seat and Concealed Instability Capsule
7	Swivel Action Base Seat
8	Support plate for seat
9	Main Frame
10	Rear foot tube assembly
11	Front foot tube assembly
12	Non-Slip cleats
13	Insert pin
14	Long insert pin
15	Insert Pin with Hole (for Core Support Column)
16	Locking Clip and String (for Insert Pin with Hole)
17	Bolt, nut, washer
18	Set of wrenches

The following is a representation for the proper Assembly of your AB Doer 360™ product. Please refer to the instructional DVD (where available) and our on-line video tutorials where available for more demonstrations of proper Assembly, combined with safety and maintenance instructions.

1. Carefully open your AB Doer 360™ box. Do not cut into the box or slice the tape to prevent cutting any inside materials. Carefully remove all protective wrapping without slicing into parts. Separate all items from the box.

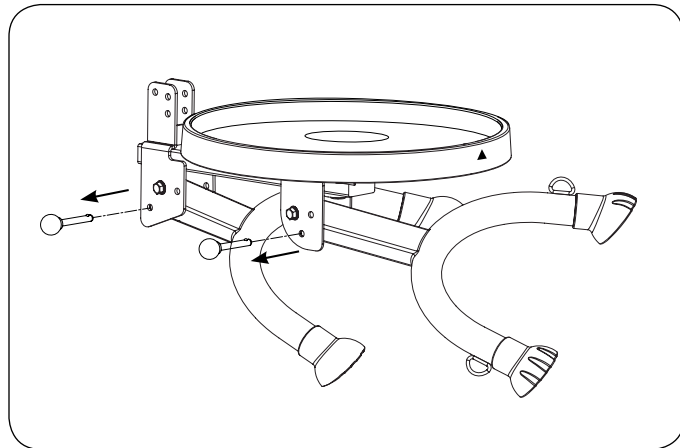
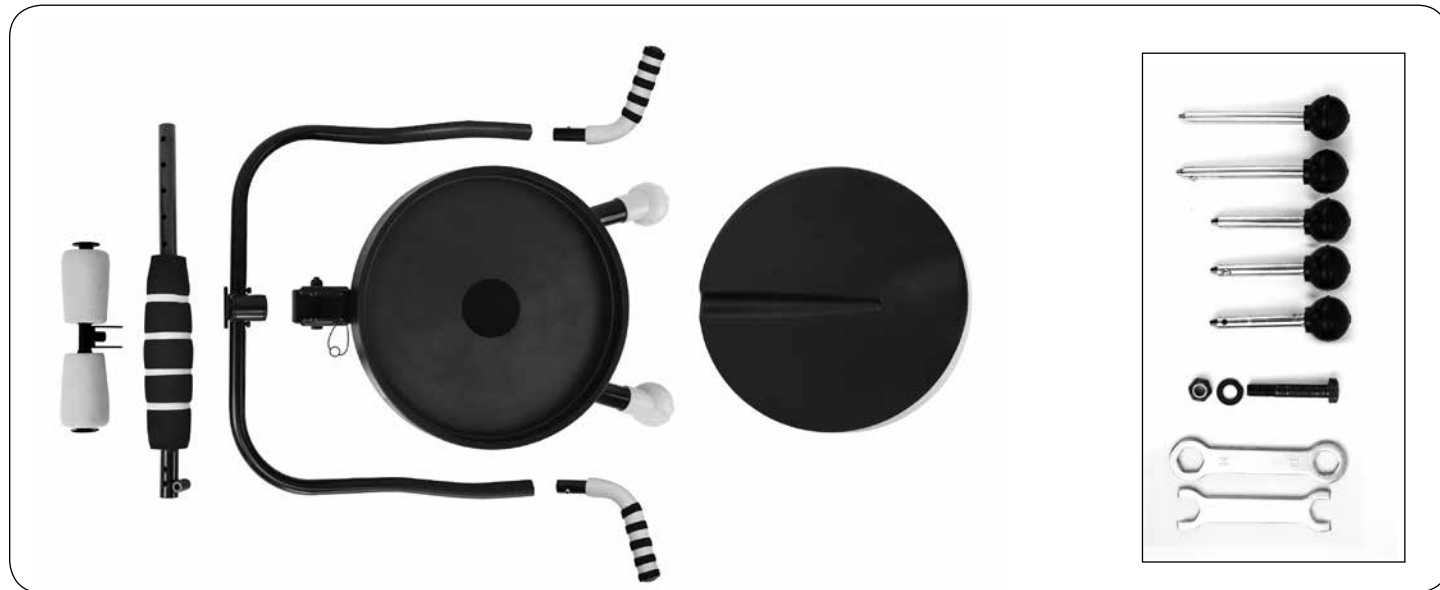

2. Take the 'Main Frame' assembly and remove the front and rear 'Long Insert Pins' that are holding the U-Shaped Base Legs in place.

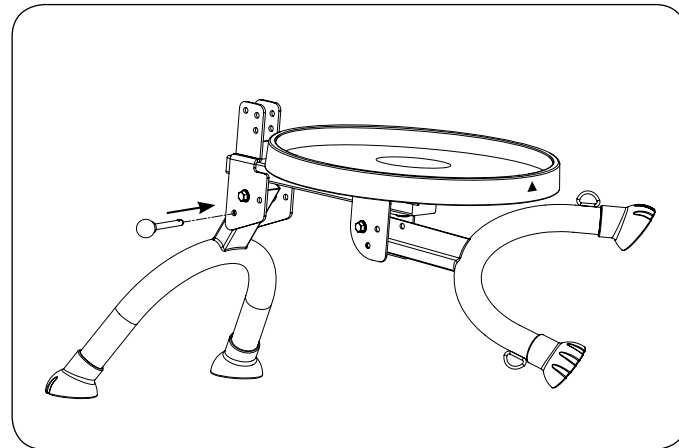

3. Unfold the rear U-Shaped 'Base Leg' and re-insert the 'Long Insert Pin' that aligns with the insert holes.

CARBOHYDRATES: (Simple) (All fruit)	1 SERVING
Apple	1 whole
Banana	1 whole
Blueberries	1 cup
Cantaloupe	1/4 melon
Cherries	1 cup
Dates	1/4 cup
Figs	1/4 cup
Grapefruit	1/2 whole
Grapes	1/4 cup
Ice Cream (No fat)	1/4 cup
Melon	2"/5 cm wide slice
Orange	1 medium size
Papaya	1/2 medium size
Pear	1 medium size
Peaches	1 medium size
Pineapple	1" slice
Plums	2 medium size
Strawberries	1 cup
Sherbet (Low sugar)	1/2 cup
Raisins	1/4 cup
Yogurt (No fat, low sugar)	6-8 oz./170-227 gm
BEVERAGES	
Water	8 oz./236 ml
Fruit Juice	8 oz./236 ml
Vegetable Juice	8 oz./236 ml
Skim Milk	8 oz./236 ml
Coffee/Tea	1 cup
Soft Drinks (No sugar)	8 oz./236 ml
FATS	
Butter	1 Tablespoon
Nuts	1/4 cup
Oils	2 Tablespoons
Seeds	1/2 cup
Sour Cream	1 oz./28 gm
Peanut Butter	2 Tablespoons

# FOOD CATEGORY & SERVING SIZE LIST

[Partial Listing \*]

PROTEIN	1 SERVING
Eggs	2 eggs (2 whites, 1 yolk)
Turkey	8 oz./227 gm
Chicken	8 oz./227 gm
Meat (lean red)	8 oz./227 gm
Fish	8 oz./227 gm
Shellfish	4 pieces
Soybeans	1 cup
Cheese (Low or No fat)	2 oz./57 gm
Cottage Cheese (Low fat, Low Sodium)	4 oz./113 gm
CARBOHYDRATES: (Starchy)	
Beans	1 cup
Rice	1 cup
Oatmeal	1 cup
Cereals (natural)	1 cup
Corn	1 cup or 1 ear
Pancakes	5"/12.7 cm diameter, 2 each
Waffles	5"/12.7 cm diameter, 2 each
Potato	1 medium size
Pasta	6 oz./170 gm
Rye Bread	1 slice
100% Whole Wheat Bread	1 slice
Muffins (No fat)	1 whole
Crackers	4 pieces
CARBOHYDRATES: (Fibrous) (Mostly vegetables)	
Alfalfa Sprouts	1 cup
Beets	1 cup
Broccoli	1 cup
Cabbage	1 cup
Carrots	1 medium size
Cauliflower	1 cup
Cucumber	1 cup
Leaf Lettuce	1 cup
Mushrooms	1 cup
Onions	1 cup
Radishes	1 cup
Tomato	1 medium size

# ASSEMBLY

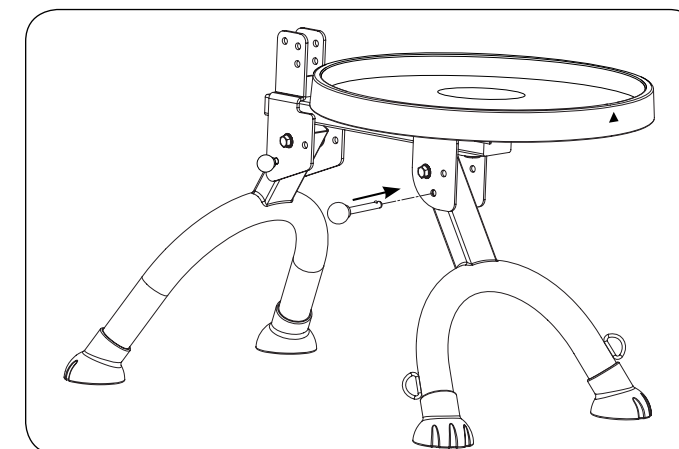

4. Unfold the front U-Shaped 'Base Leg' and re-insert the 'Long Insert Pin' that aligns with the insert holes.

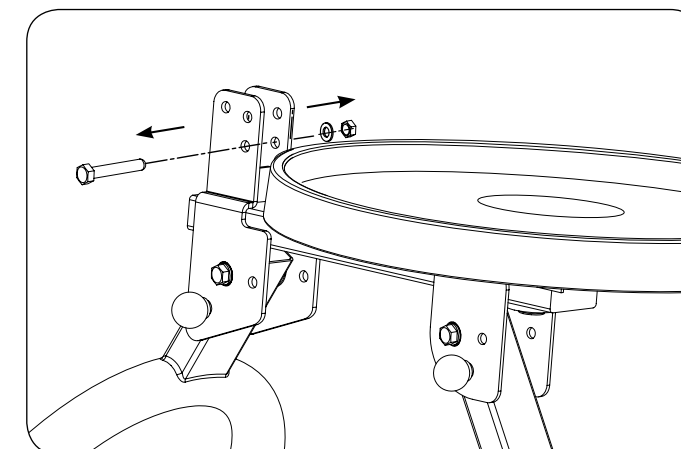

5. Disassemble the 'bolt, washer and nut' that's affixed to the rear bracket on the 'Main Frame'.

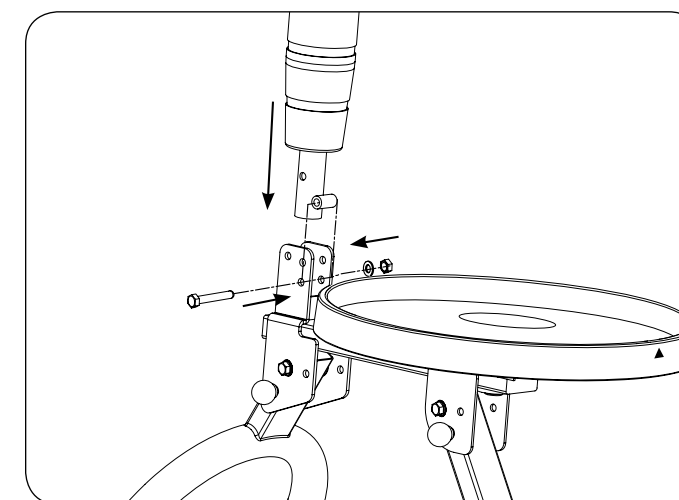

6. Insert the 'Core Support Column' into the rear bracket on the 'Main Frame' then re-insert the bolt through the bottom hole on the bracket (make sure to remove the twister tie from the sleeve). Insert the washer and nut and tighten by using the supplied wrenches (or you can use your own wrenches).

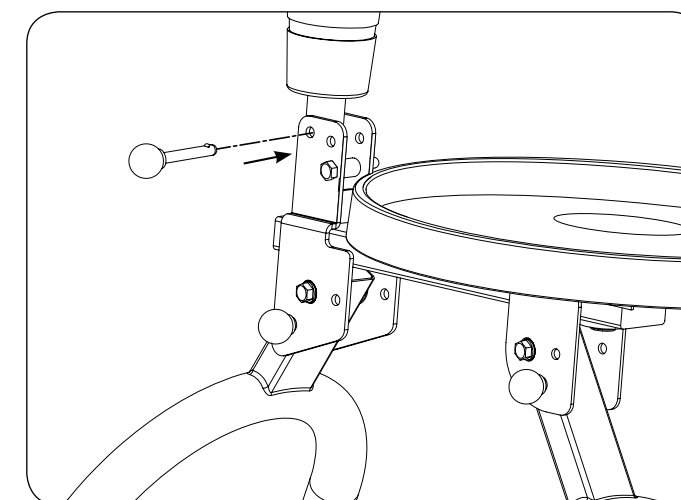

7. Once the bolt/washer/nut are fastened into the bracket, to hold the 'Core Support Column', slide in the 'Insert Pin with Hole' into aligned holes to secure an upright (vertical) position of the 'Core Support Column'. Secure the 'Insert Pin with Hole' by inserting the Locking Clip (attached to the String) into the hole on the insert pin.

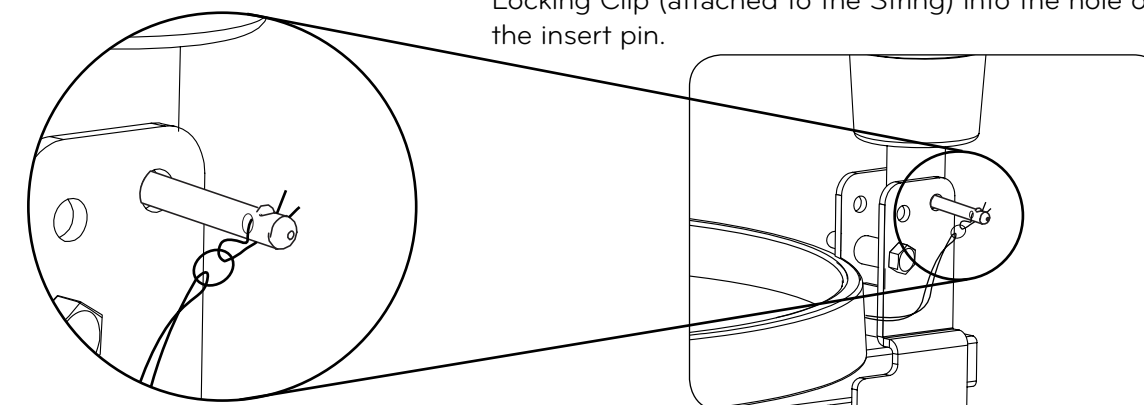

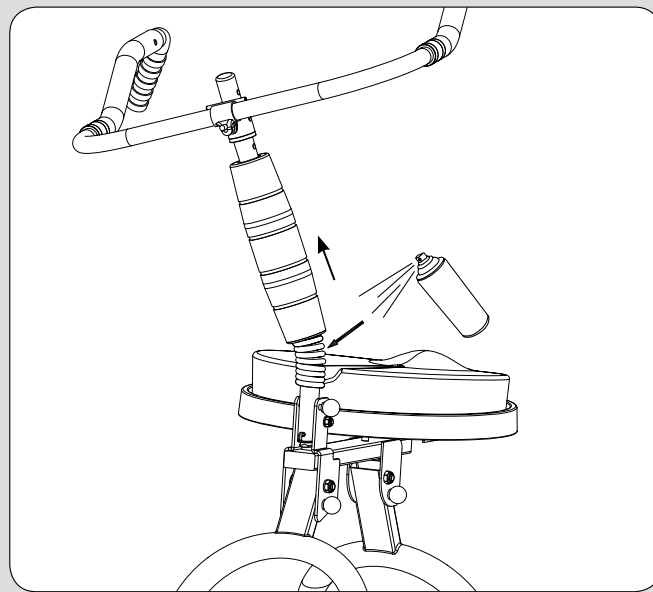
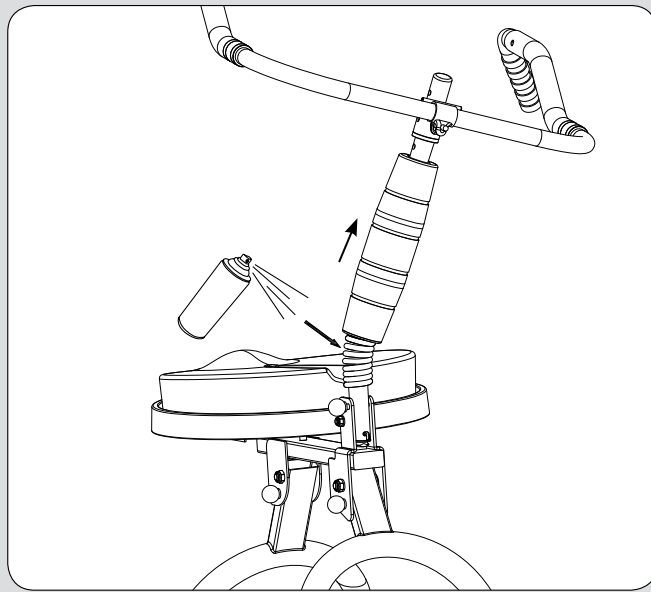

**IMPORTANT!**  
If your AB Doer 360™ machine starts producing a squeaky sound after some prolonged use, it can be easily eliminated by lubricating the coil part of the Core Support Column. Simply slide up the foam cover around the coil and apply a lubricating oil on the coil while bending the Core Support Column by approximately 30 degrees to both the right and left side. Wipe off any excess lubricant. Slide down the foam cover.

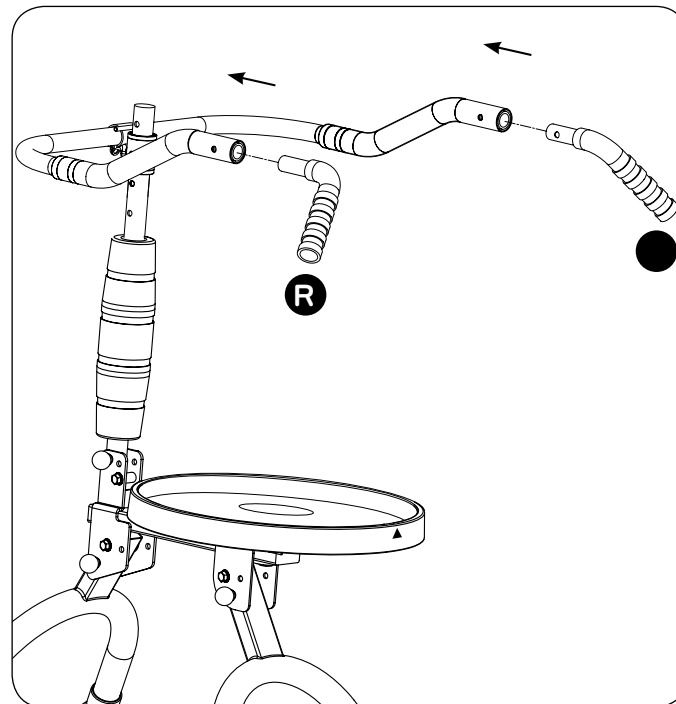
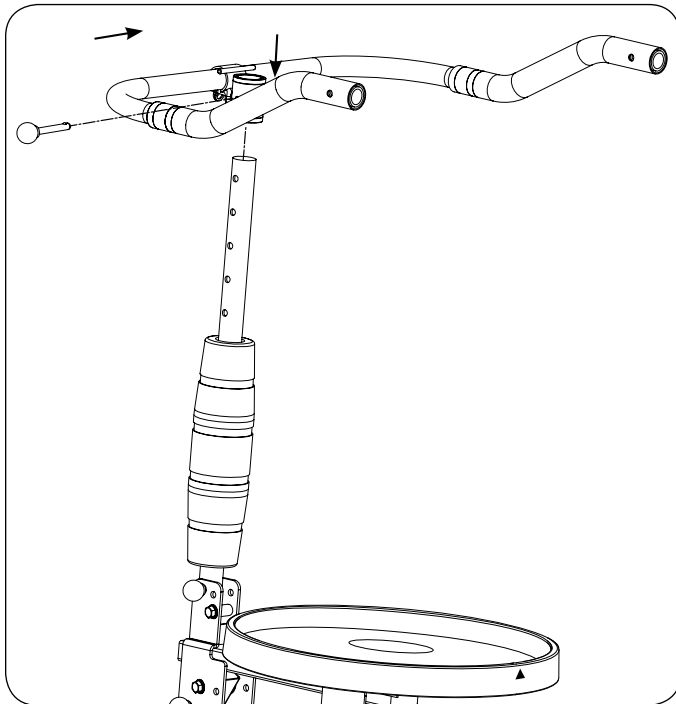

8. Attach the 'Contouring Arm Bars' onto the upper part of the 'Core Support Column', and slide in the 'Insert Pin'.

9. Insert the L and R 'Dynamic Hand Grips' into the ends of the 'Contouring Arm Bars'. When you hear a 'clicking' noise and seeing a silver rounded knob poking out of the 'Contouring Arm Bars' the 'Dynamic Hand Grips' are in place.

**NOTE:** the 'Contouring Arm Bars' freely rotate upward and downward. This is normal function, and very useful for many of the Abdoer motions.

**Sample Meal Wheel 'tem-Plate'**

(Completed)

Example:

Pro	Chicken Breast
Carb-F	Broccoli
Carb-C	Baked Potato

Each Meal Wheel 'tem-Plate' lists the three major Food Categories: Protein, Carbohydrate Fibrous and Carbohydrate Complex (Starchy). When you have selected your foods simply insert them into their respected locations onto your own plates, creating your own meals! Be creative and design as many variable meals that align with each 'tem-Plate' suggestion.

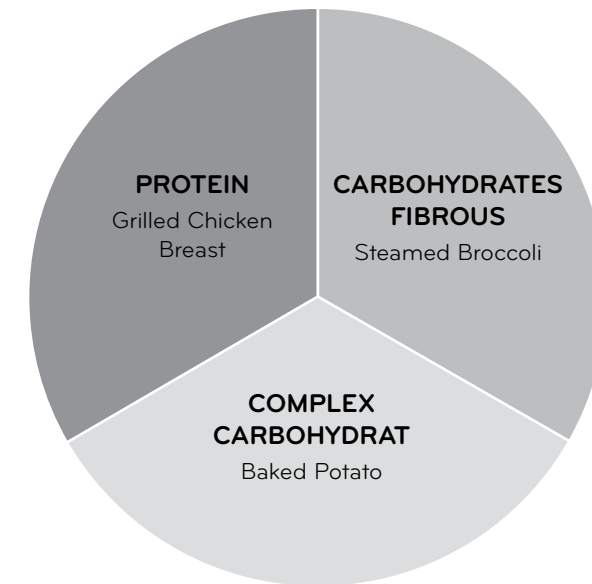

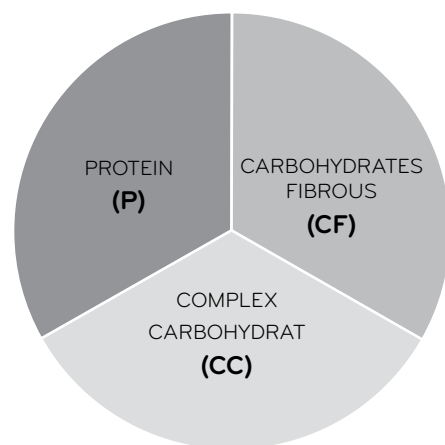

**Weeks 1-4**  
BASICS

Consume equal portions of the represented Food Categories for each meal; breakfast, lunch and dinner. Second helpings must be of the same balance, not a single food item.

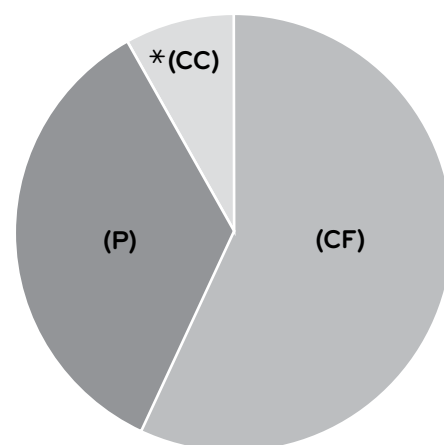

**Weeks 4-6**  
BASICS

Reducing CC while concurrently increasing Protein and Carb Fibrous food sources.  
\* Permitted 1 time daily, and also after workouts. Do not eat CC after 6 pm during this mini-cycle

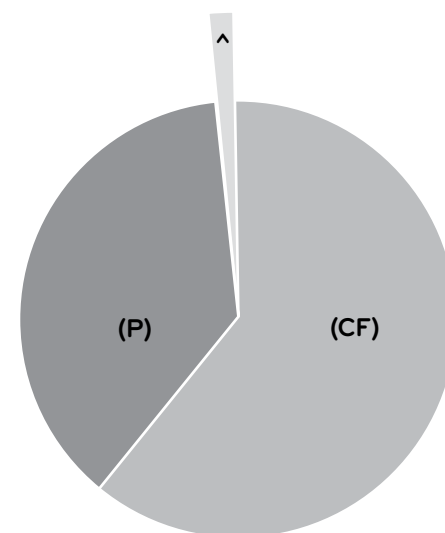

**Weeks 6-8**  
BASICS

^ Limit CC to 3 times weekly, Post Workout. Eliminate CC from all other meals during the week. Stop using the salt-shaker. After your last meal of the day perform an easy Abdobice™ routine, or easy aerobics like walking for 20-30 minutes. After the conclusion of Week 8 simply resume the 8-week cycle from the beginning. Each time you get better and better.

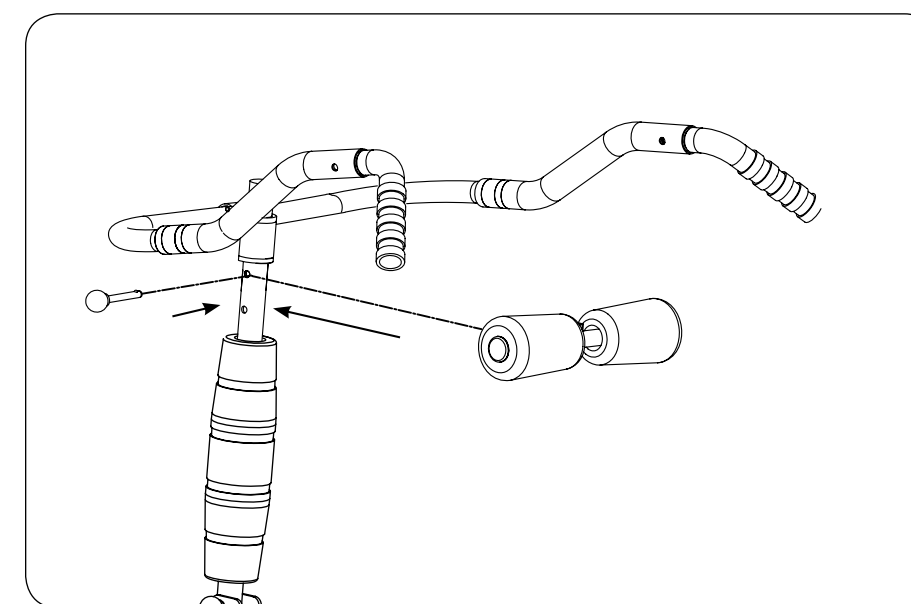

10. Attach the '2-Pack Massage Rollers' below the 'Contouring Arm Bars' by sliding in the 'Insert Pin'.

Both the 'Contouring Arm Bars' and '2-Pack Massage Rollers' are adjustable upward or downward for your body height by simply choosing any one of the various insert holes vertically aligned on the 'Core Support Column'. This adjustability is also extremely useful to offer exercise diversity for many applications.

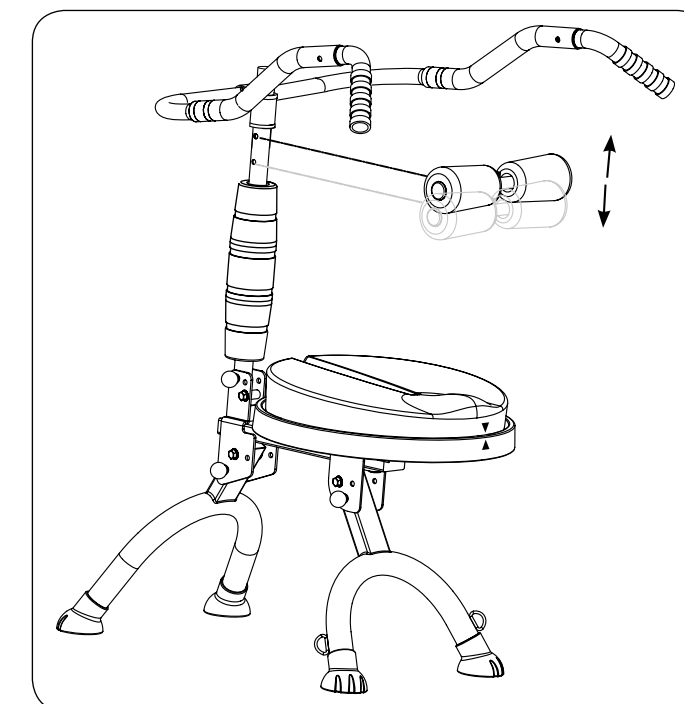
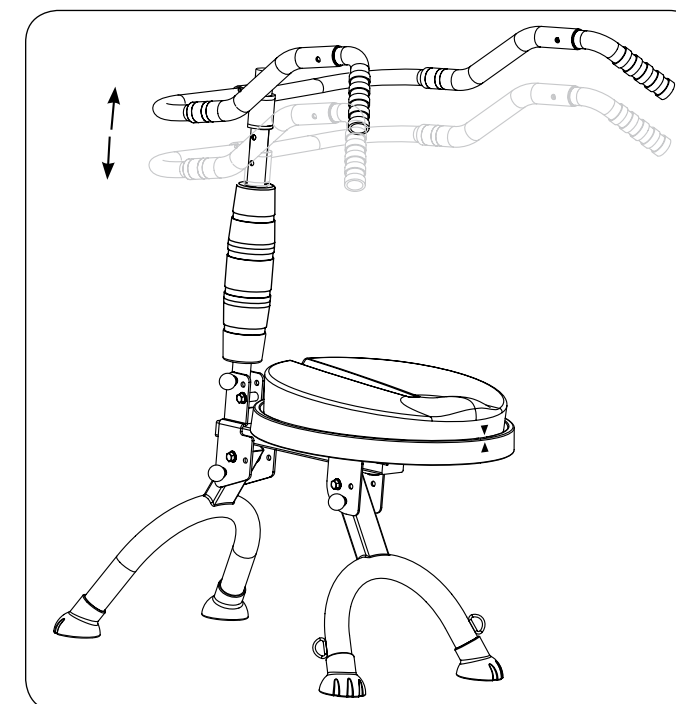

**DYNAMIC FLUIDITY SEAT**

The 'Dynamic Fluidity Seat' offers Left-to-Right rotational (or twisting) swivel actions as well as a 360° wobbling motions.

The 'Dynamic Fluidity Seat' and the concealed (green-colored) 'Concealed Instability Capsule' are affixed to one another.

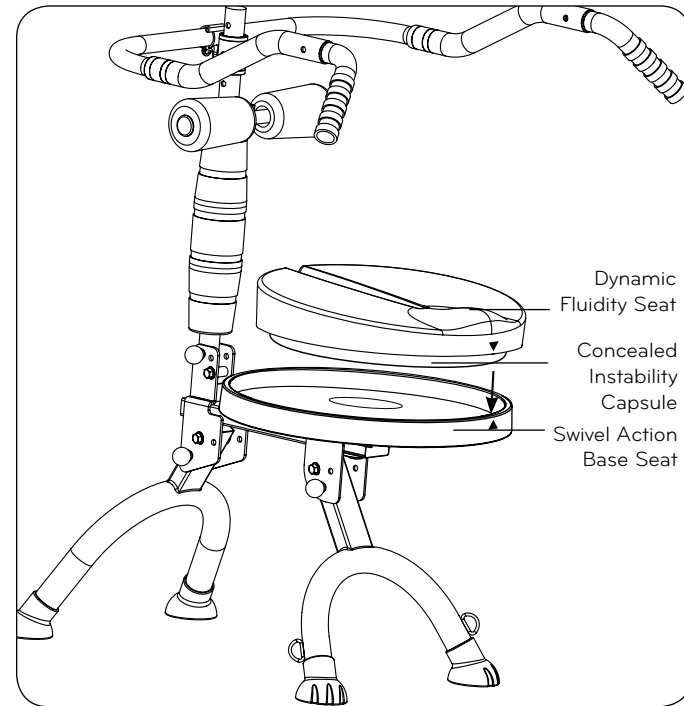

To remove the 'Dynamic Fluidity Seat' simply lift one edge to release the hook and loop tapes connection. Perform this action slowly while holding firmly so as to not damage the hook and loop tapes connection. Removing the 'Dynamic Fluidity Seat' allows you to enjoy calorie-burning Abdoer technology at work, or while watching TV. Simply position the 'Dynamic Fluidity Seat' on any other appropriate chair or bench, i.e. office chair, dining chair etc. Simply sit on the 'Dynamic Fluidity Seat' and you'll automatically engage muscles in what's called 'Passive Action' that increases muscle contractions, all while you're seated.

Start using the 'Dynamic Fluidity Seat' for about 30-45 minutes at a time and increase the usage time to your preference. Continue taking it On and OFF at preferred intervals throughout the day.

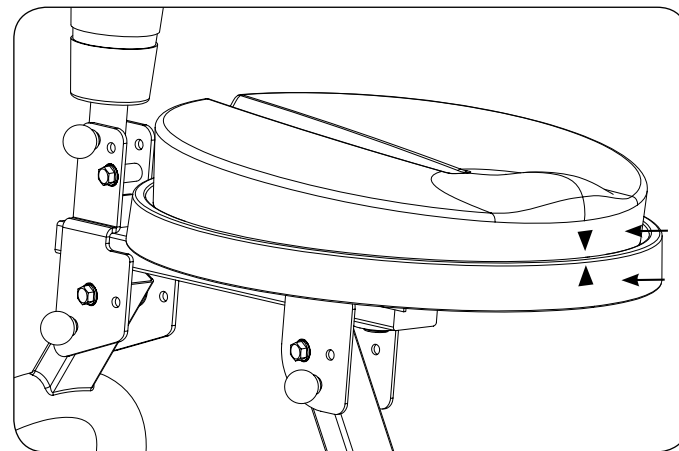
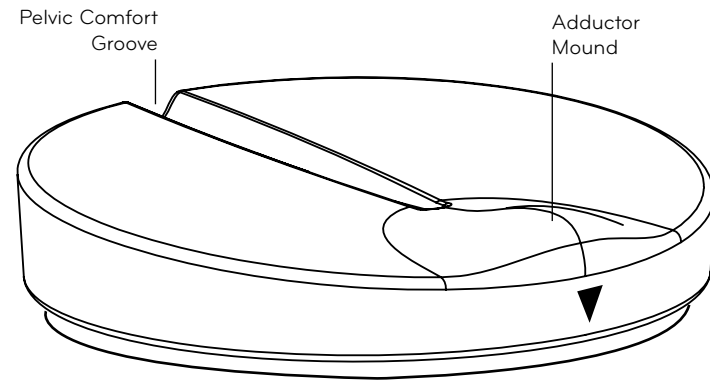

11. Affix the 'Dynamic Fluidity Seat' onto the 'Swivel Action Base Seat' by aligning the Center Makings, as illustrated above. It's very important to correctly position the 'Dynamic Fluidity Seat' onto the unit, so the 'Adductor Mound' is on the front side and the 'Pelvic Comfort Groove' is on the back side.

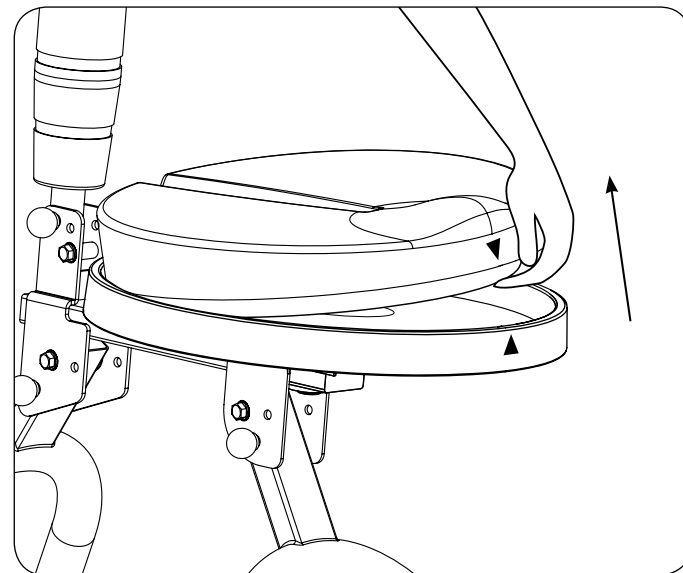

**Eating Tips**

- On the Do N.O.T. Diet you will eat multiple times every day. Snacks and meals are evenly spaced; like every 3-4 hours, consistently.
- Missing meals only slows your metabolism, so eat, but eat smart.
- When you begin to exercise more regularly, especially with your Ab Doer 360™ ABDOBICS™ system, your body will require adequate nutrition while, concurrently, you'll become more efficient at burning off excess fat. I call this 'Metabolic Momentum™'.
- When you're confronted, or tempted, with a food or snack choice that isn't in your body or health's best interest, you must simply choose an alternate food source. Developing strong emotional control over your cravings is an essential principle for becoming a successful Doer!
- **CF:** Multiple sources of foods allowed, like a salad or mixed veggies, etc.
- **CC:** Only one source allowed, never two or more; like combining hash browns and toast, or pasta and bread.
- Eat until you feel that 'near full' feeling. Never over eat. It's best to turn one meal into two meals 'leftovers allowed'.
- You will notice three (3) 'Mini-Cycles' within your '8-Week Phase'. They're scheduled as follows:
  - The transition from one 'Mini-Cycle' to the next 'Mini-Cycle' doesn't always have to be on an exact day. Rather, as you're nearing the completion of one 'Mini-Cycle', simply start to make the transition until you complete the entire '8-Week Phase'.
  - After completing an entire '8-Week Phase' simply return to the beginning and start up all over again.
  - The advantage for transitioning between the 'Mini-Cycles' is that you can easily adjust to the recommended modifications in food portions. During each transition you're intentionally reducing and/or eliminating certain foods for short periods while, concurrently, consuming equal or more nutritional calories from other categories. This way you'll always be eating, but eating smart and eating right, and never feeling deprived.
- You can eat anytime, even late at night, with the exception of no CC and/or CS late at night.
- **CONDIMENTS** like mayonnaise, ketchup, and mustard, as well as sauces, salad dressings, and gravies, are to be diluted with water and used sparingly. However, when you're trying to lose excess body fat in the fastest manner possible, avoid many of these items altogether as they contain hidden fats, sugars, salts, preservatives and other fat-promoting calories.
- Water must 'ALWAYS' be consumed in large amounts daily.
- Sodium intake needs to be curtailed when you're striving to lose excess pounds and inches, as this self-applied strategy will reduce edema, or bloating. For those who sweat profusely, or are subject to high temperatures, (moderate) sodium intake is recommended.
- Caffeinated drinks are allowed but best to avoid sugar-loaded high-energy drinks; even the 'no sugar' brands. And best to rely on fresh coffee or herbal teas; minus the creams and syrups, etc.
- When you lower or eliminate your CC you can increase essential Fat intake with such items as (conservative portions) of coconut oil, olive oil, nuts, seeds, nut butter (just a light spread), avocado, natural butter, fatty fish (salmon, etc.), egg yolks, etc.

**Mini-Cycle Guidelines:**

(Basics)

- Weeks 1-4: Maintain an equal 1/3 x 1/3 x 1/3 balance as shown in the 'tem-Plates'.
- Weeks 4-6: Reduce CC while concurrently increasing P and CF.
- Weeks 6-8: Eliminate CC and sodium for the next 2+ weeks; or until this Mini-Cycle is completed.

The elimination of CC will rob fat cells and assist with your Accelerated Results™. Lowering sodium will reduce bloating and assist in achieving better results with your measurements.

## HOW TO COMPLETE YOUR MEAL 'TEM-PLATE'

(Refer to illustrations)

**STEP 1:** Imagine the Meal Wheel 'tem-Plate' as an actual food plate that's divided into three equal parts: 1/3rd for Protein, 1/3rd for Complex Carbohydrate and 1/3rd for Fibrous Carbohydrates.

**STEP 2:** Scan the Food Category & Serving Size List and select the food/s that correspond with each category. Example, for Protein, you can select either chicken or eggs or fish, etc.

**STEP 3:** Insert the corresponding food item onto each third of your plate then eat. It's that simple!

### GUIDELINES

- **Carbohydrates – Simple** are allowed earlier in the day and after exercise, and can be used as snacks. Avoid eating late at night, and drinking fruit juices.
- **Fats** are automatically present in most Protein foods, like eggs, meat, chicken, many fish, etc., but you can consume healthy fats like Extra Virgin Olive Oil, Coconut Oil, Organic Butter, and Avocados, to name a few.
- **Beverages** should be limited to water, fresh vegetable juices, coffee and herbal teas. Fruit juices are extremely high in sugar so, again, limit or avoid fruit juices. Sodas, high-energy drinks, and flavored coffee drinks are not recommended.
- **SPICES** are terrific to boost nutritional profile of your meal/snack and add flavor. Limit shaking the saltshaker as there's plenty of sodium in most foods, especially if you dine in restaurants.
- **SNACKS** are allowed, but not what many consider a 'snack' to be. A small piece of fruit or a piece of a vegetable, cottage cheese, small handful of raw nuts or seeds, or a meal replacement bar or shake. We're not talking about candy or anything considered 'junk food'.

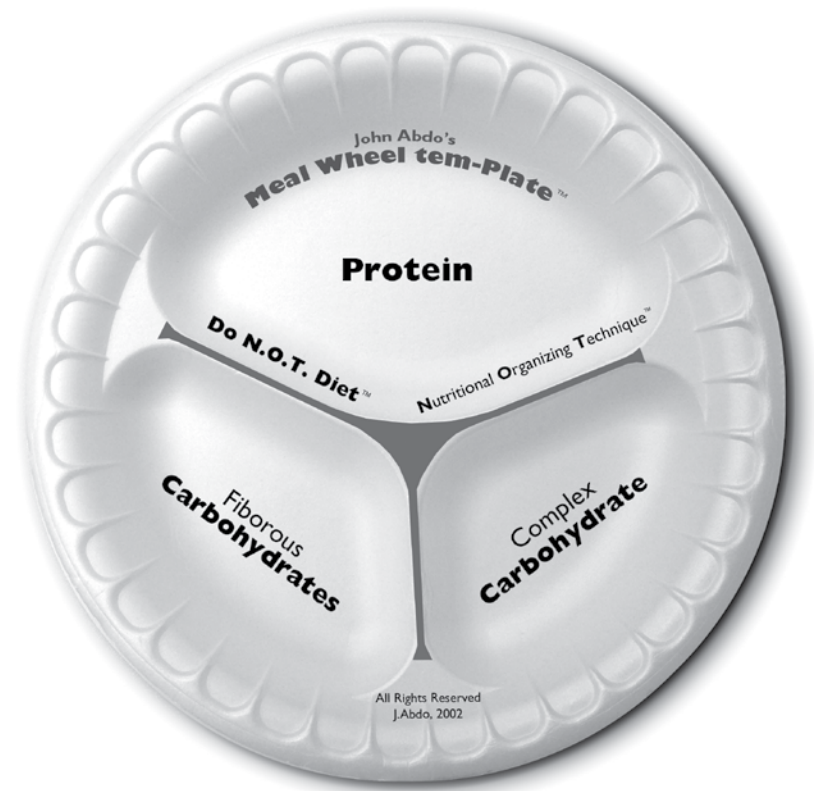

## ASSEMBLY

### IMPORTANT!

Always mount and dismount the AB Doer 360™ after aligning the 'Center Markings' to make certain your Dynamic Fluidity Seat is centered. Never mount or dismount diagonal or from either side of the unit. Never sit on the unit facing the Core Support Column. When mounting and/or dismounting always make certain you're entire body is secure so you don't stumble or fall. When performing any exercise or routine, transition from movement to movement using care and caution.

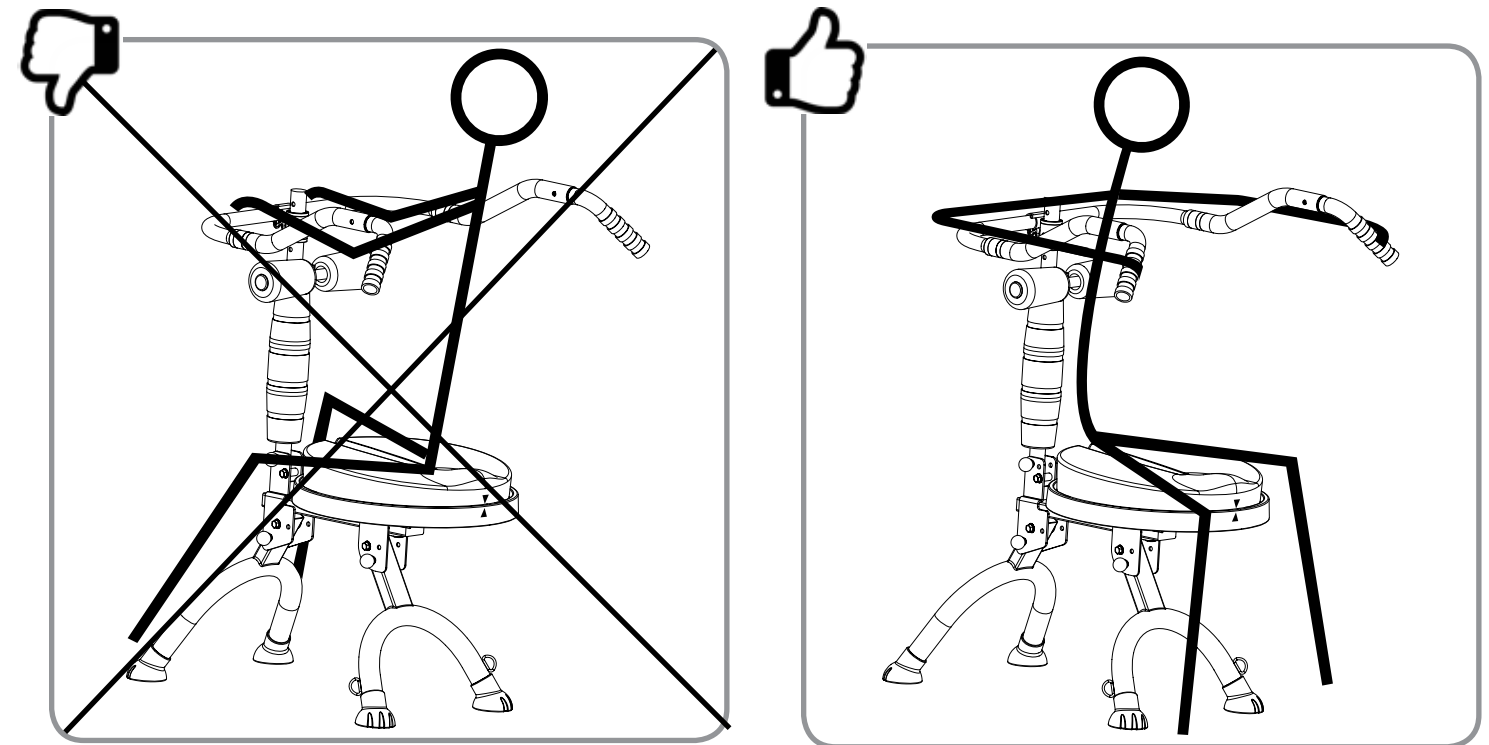

AB Doer 360™ is a dynamic product comprised of many moveable components. All of these items are to be safely and effectively activated only after you are positioned in a secured seated upright posture. Some of the moveable parts include the Core Support Column, Arm Bars, Massage Rollers and Dynamic Fluidity Seat, Instability Capsule. Therefore, if you grab onto any of these items when mounting and/or dismounting you can stumble or fall.

Before beginning your workout program, please read through these guidelines

Make sure that you have enough space around your AB Doer 360™ machine so you can exercise freely, and safely.

The diagrams on this page demonstrate the 'Training area' (Figure 1a & 1b) as well as the minimal 'Free area' (Figures 2a & 2b) that should be available around you while you are working out on this unit.

TRAINING AREA

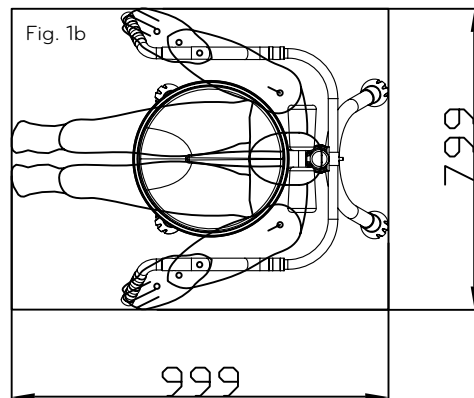
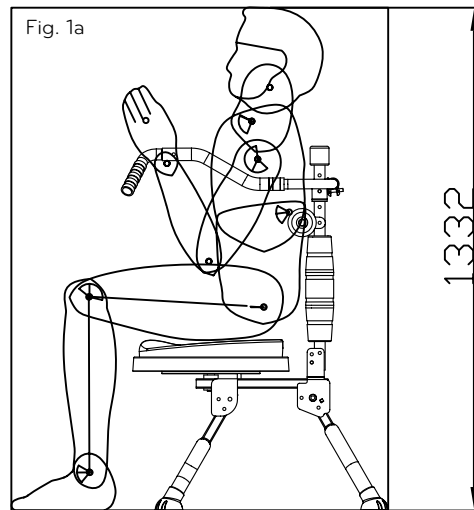

FREE AREA

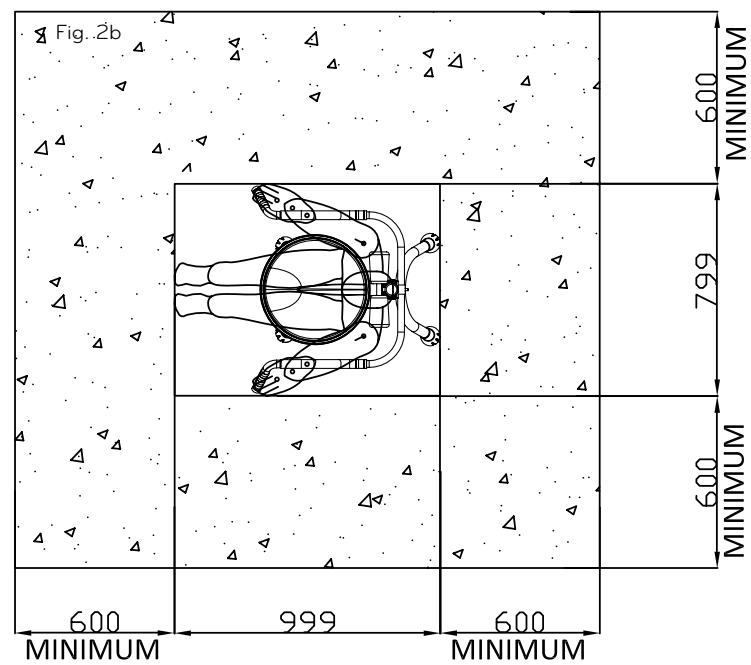
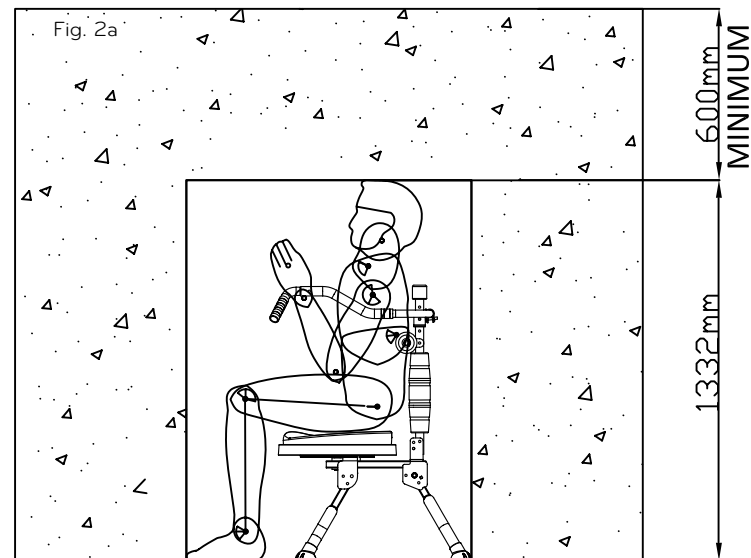

**Meal Wheel 'tem-Plate'** has been designed to allow you to follow a simple, systematic and accurate food selection plan that offers variety and ensures nutritional and/or caloric balance. As you view the charts you will notice the top three Food Categories; 1) Protein, 2) Carbohydrate – Complex and 3) Carbohydrate – Fibrous are listed in specific portion amounts. These 'portion amounts' are equal 1/3rd x 1/3rd x 1/3rd to fill your plate, while these percentages will slightly modify during each of the three evenly paced 'Mini-Cycles' for each '8-Week Phase' of your Doer Challenge.

**When designing your meals using the Meal Wheel 'tem-Plate', simply place the food item/s you selected from the listed Food Category onto that portion of your plate, it's that simple!**

You're allowed to eat as much of that meal until you reach that 'near full' feeling, then stop and package the remainder of that meal for a 'left-over' later on. Eating in this fashion will 1) ensure better nutritional and/or Food Category balance, 2) reduce caloric over-loads, 3) sufficiently fill your stomach for proper satiation, 4) assist your metabolism with its digestive responsibilities, and 5) help accelerate your fat-burning, muscle-strengthening and health-promoting metabolism. (You can imagine that it's easy to take advantage of any eating plan so you must exercise control over food and meal portions to avoid over consumption.)

**Do N.O.T. Diet™** is very easy to understand, and extremely simple and enjoyable to apply. Based on the provided Meal Wheel 'tem-Plate,' (See Meal Wheel tem-Plate™ (Refer to Meal Wheel tem-Plate™, page 40) you will select and arrange your own meals—from the foods you normally eat or have access to. There is no need to weigh your food on scales and you won't need to count calories. I believe counting calories is an inexact science. For instance, a fresh banana has far less calories than a fully ripened banana; while most, if not all foods have caloric variances that are difficult to monitor and accurately account for, so counting calories can be erroneous.

**Do N.O.T. Diet™** allows you to eat many of the foods you simply have access to, or can't give up. This is also the perfect plan that allows you to eat in places you're unfamiliar with, like new restaurants, etc., so you can remain committed to the plan without veering off track.

## N.O.T. IS SO SIMPLE: 3-Easy Steps

Before you can understand the simplicity of the Meal Wheel 'tem-Plate,' you first need to learn how to identify with the various Food Categories and the individual food items that fall under each of these Food Categories.

FOOD CATEGORY	ABBREVIATIONS
Protein	P
Carbohydrate - Fibrous	CF
Carbohydrate - Complex	CC *
Carbohydrate - Simple	CS
Fats	F
Beverages	B

\* Also referred to as 'Carbohydrate - Starchy'

You will notice there are three (3) distinct Categories for Carbohydrates; 1) Fibrous, 2) Complex and 3) Simple. Each of these sources offer different nutritional and caloric profiles, while it's important to balance them when arranging a meal. For instance, just eating a bowl of pasta, along with some bread for dinner; which is limited to only one Food Category; i.e., CC, is an overload for this Food Category that can create caloric and/or nutritional imbalances because this is a one-sided eating approach.

Please refer to the 'NUTRITIONAL GUIDELINE: Food/Serving List' below to locate and select the individual food items that fit into each of the Food Categories above. Examples, to locate and select a 'Carbohydrate - Fibrous' (CF) peruse the listing and you'll locate such foods items like broccoli, cauliflower, lettuce, etc. Because there are so many other food items and variables not listed on the NUTRITIONAL GUIDELINE chart, you can include other foods based on your discretion.

Please note that other food categories like Carbohydrate - Simple (CS), fats, beverages, spices or condiments can be included into your meals for flavor-enhancing and/or nutritional benefits.

## STORING OR TRANSPORTING

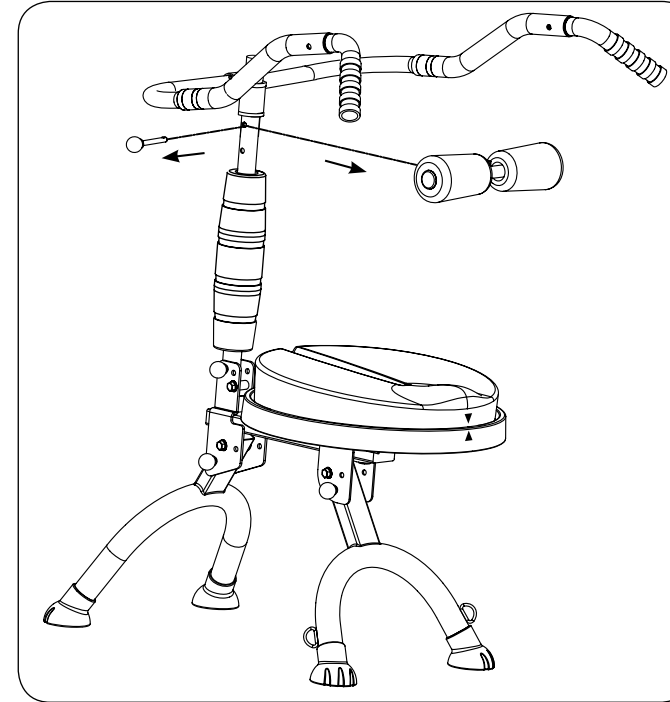

1. Remove the 'Insert Pin' and detach the '2-Pack Massage Rollers'

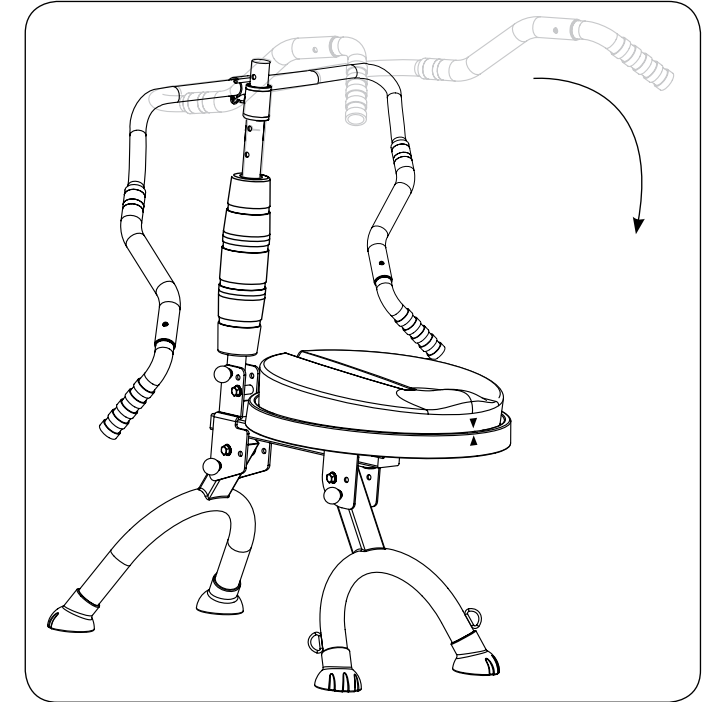

2. Fold down the 'Contouring Arm Bars'

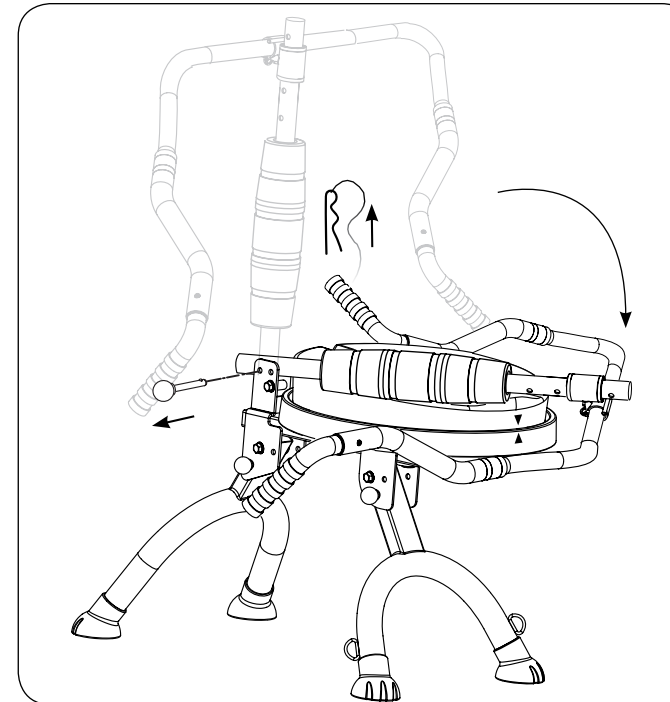

3. Fold down the 'Core Support Column' toward the 'Dynamic Fluidity Seat' by releasing the Locking Clip and removing the 'Insert Pin with Hole'

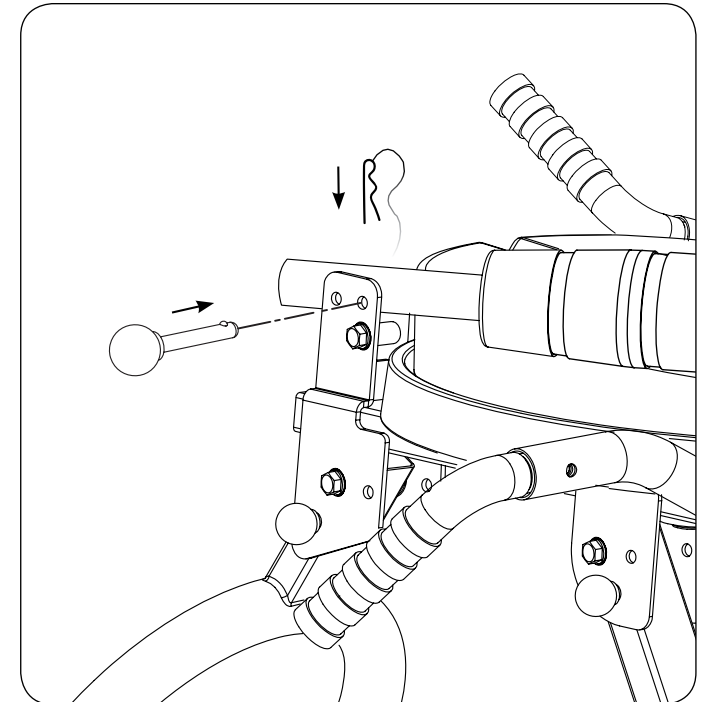

4. After the 'Core Support Column' is folded down onto the 'Dynamic Fluidity Seat,' re-insert the 'Insert Pin with Hole' into the 'bracket' to lock the 'Core Support Column' into place and secure with the Locking Clip.

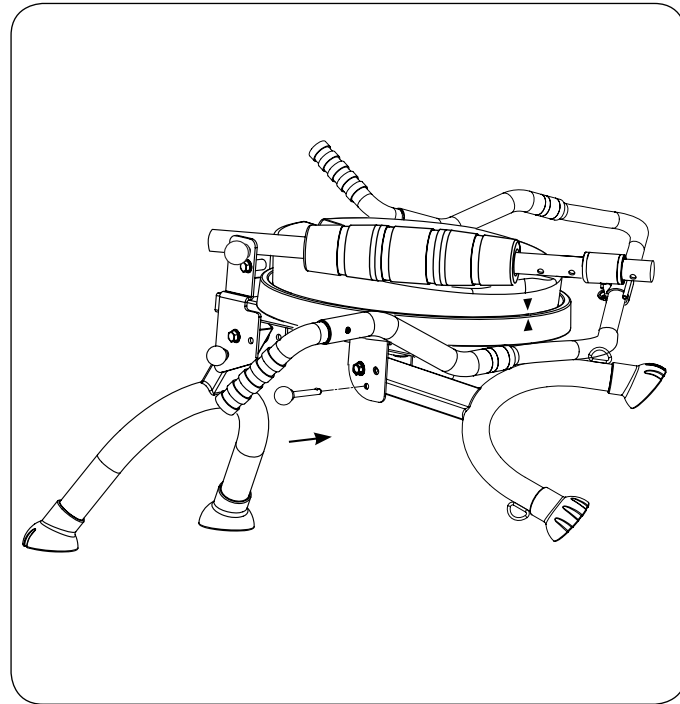

5. Carefully remove the 'Long Insert Pin' from the front 'U-Shaped Base Leg', fold it underneath the unit and re-insert the 'Insert Pin' to lock into place.

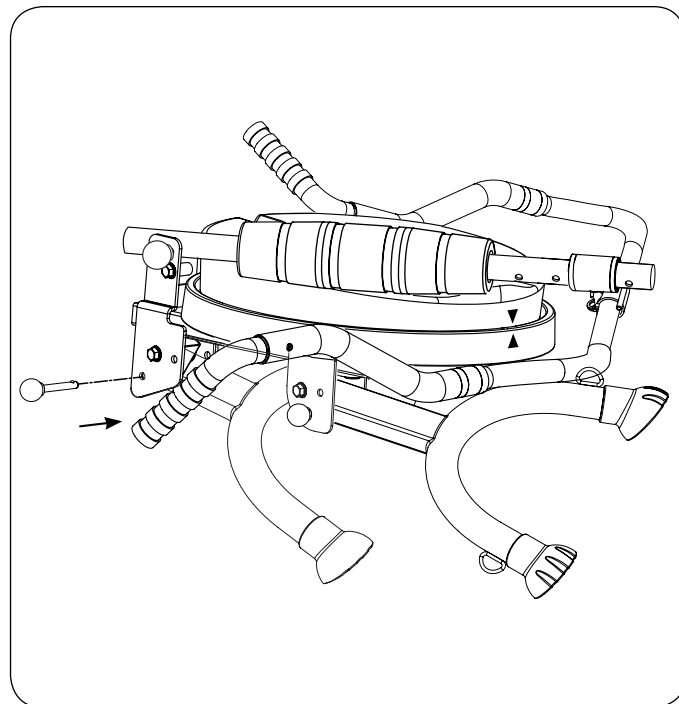

6. Perform the same action as explained in #5 above for the rear 'U-Shaped Base Leg'; removing its 'Long Insert Pin', folding it underneath the unit and re-insert the 'Long Insert Pin' to lock into place.

**NOTE:**

Always re-insert the 'Insert Pins' when removed as these are free-moving items that can be misplaced, or lost.

# Do N.O.T. Diet™

## Eating Plan Nutritional Organizing Technique™

### Let's N.O.T. Eat Correctly: It's so simple . . .

**Do N.O.T. Diet™** is the diet you will enjoy, because it's not really a diet. N.O.T. represents **Nutritional Organizing Technique™**, and like it sounds, you organize your foods and nutrition with a simple technique that I'm about to explain to you.

The primary objective of the Do N.O.T. Diet eating system is based on helping its applicants learn and apply better nutritional choices and balanced eating, while avoiding deprivation and frustration. This plan offers special consideration to significant issues that include the demands for nutritional and/or caloric sufficiency, achieving ideal bodyweight and percentages of body fat, toning and strengthening muscle, and boosting overall health and performance. Unlike many other plans, the Do N.O.T. Diet™ offers simplicity, variety, convenience and satisfaction, to name a few.

Most of the popular diets, then and today, are just too difficult or impractical to follow. When people don't comply 100% with that diet's specifically recommended principles, they feel like they've failed. This is because many/most diets assign specific foods, or specific combinations of foods, that you must eat. But if you don't have access to these foods, or you simply don't like to eat them, or your lifestyle won't permit them; for religious reasons, Veganism, etc., then, again, that diet won't work for you. However, with the Do N.O.T. Diet™ you never fail; only succeed.

**Do N.O.T. Diet™** is based on eating, and plenty of it. This plan is not based on overall 'caloric deprivation'; that's very unhealthy. Instead, this plan modifies the percentages of the foods you're eating to shift away from 'fat-producing' calories and focus on consuming 'fat-depriving calories'. My objective for designing Do N.O.T. Diet was motivated in helping people, and myself, with consuming more nutritionally balanced meals, and to achieve success with a most struggling issue, 'how to eat properly'.

**Do N.O.T. Diet™** is the same plan everybody follows, no matter your age, sex, body type, bodyweight, fitness level, or objective. For couples who are partnering up, but weighing different bodyweights, Do N.O.T. Diet is the same plan for both of you, 'given food quantity adjustments'. This system really works!

Typically, **Do N.O.T. Diet™** eating plan is followed in cycles, each comprised of an '8-Week Phase' duration. Each '8-Week Phase' includes three 'Mini Cycles', spaced at periodic benchmarks within each '8-Week Phase'.

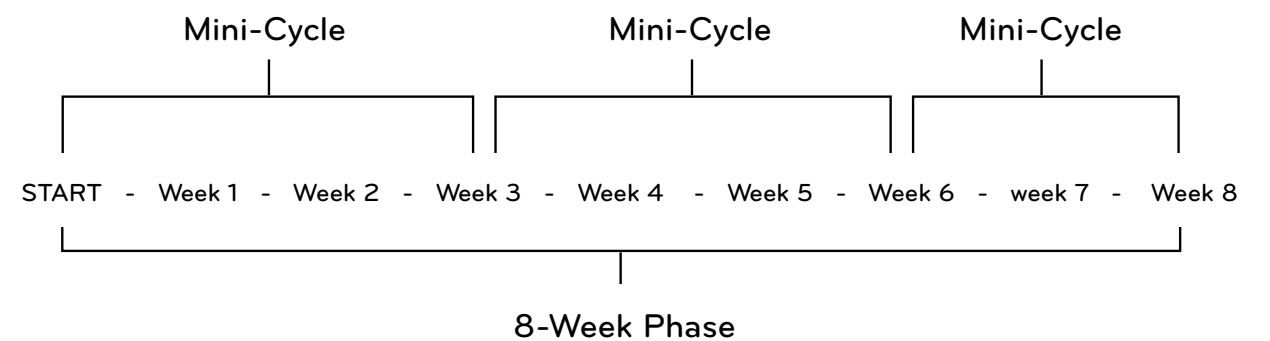

# AB Doer 360™



Healthy Eating Plan

## AB DOER 360™ ACCESSORIES - OPTIONAL

### 6-Pack Massage Roller

This is our most popular accessory item for the AB Doer 360™ machine. It does what the 2-Pack massage roller does but 'Multiplied X3'!

**NOTE:** This accessory is not suggested for the actual AB Doer 360™ aerobic workouts as it may limit your range-of-motions. Instead, the 6 Pack Roller is to be used only for back and spine stretching and mobilizing routines. Please refer to the 'Core Mobility' DVD (where available).

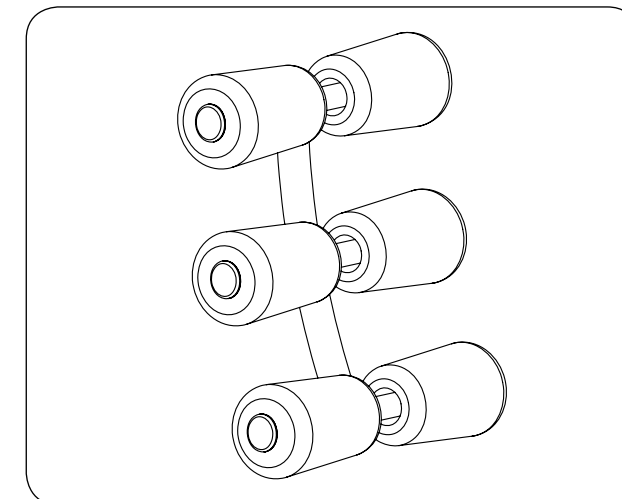

### Resistance Bands Kit

(2 different levels of resistance)

If you want to tone up your arms, shoulders, chest and back and even your thighs, hips and buttocks, then the AB Doer 360™ Resistance Bands allows you to perform the same exercises you would perform at the gym with dumbbells and barbells and cable machines. Simply attach each end of the Bands to the Hooks located on the front base legs of your AB Doer 360™ machine, and you'll be able to curl, press and row. To work your lower body, simply secure the Ankle Stirrup around your ankle and kick, lift and push your legs, hips and buttocks into their best shape ever. Progressive resistance options keep you challenged and realizing great results from workout to workout.

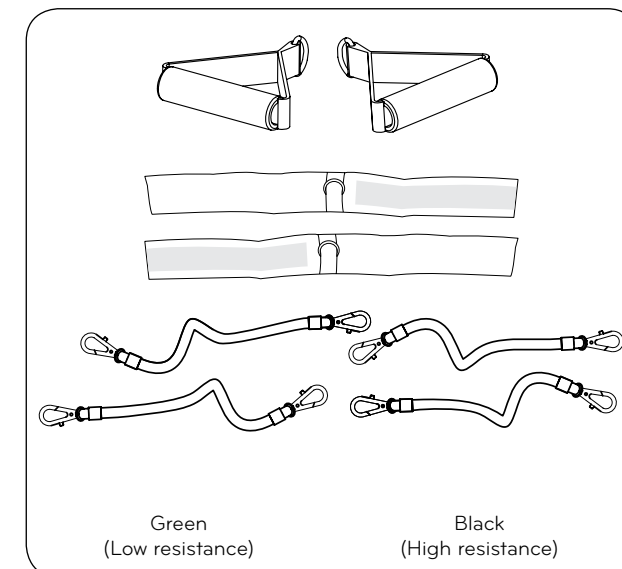

### Power Rods

(3 different level of resistance)

This set of Power Rods allows you to add extra resistances to your AB Doer 360™ machine with its triple progressive resistance options. Simply select Light (#1/Yellow Label) for a higher level aerobic challenge, Medium (#2/Orange Label) for a cross-training combination of aerobics and muscle toning, and Advanced (#3/Red Label) for the ultimate in calorie burning and muscle toning.

These triple progressive resistance options are extremely easy to insert and remove into your AB Doer 360™ machine allowing you to have even more variables, and results, while using your AB Doer 360™ machine!

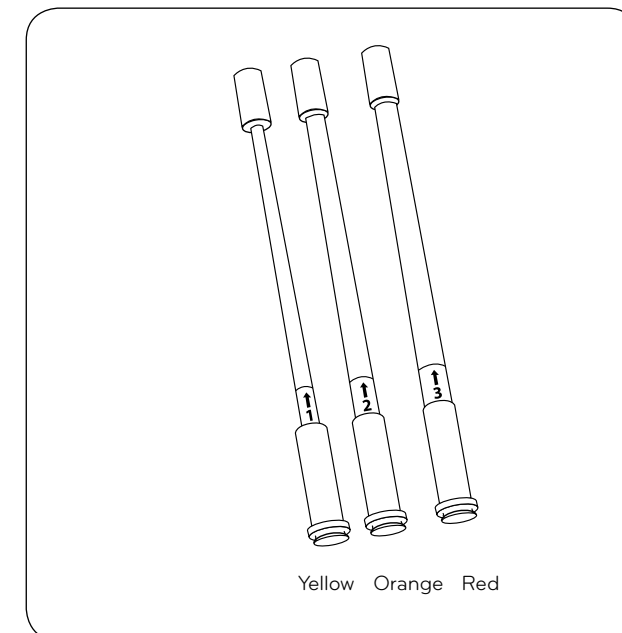

**NOTE:** These added resistances are only intended for aerobic fat-burning benefits, as they're not intended to overstress muscles to enlarge or hypertrophy.

6 Pack Massage Roller

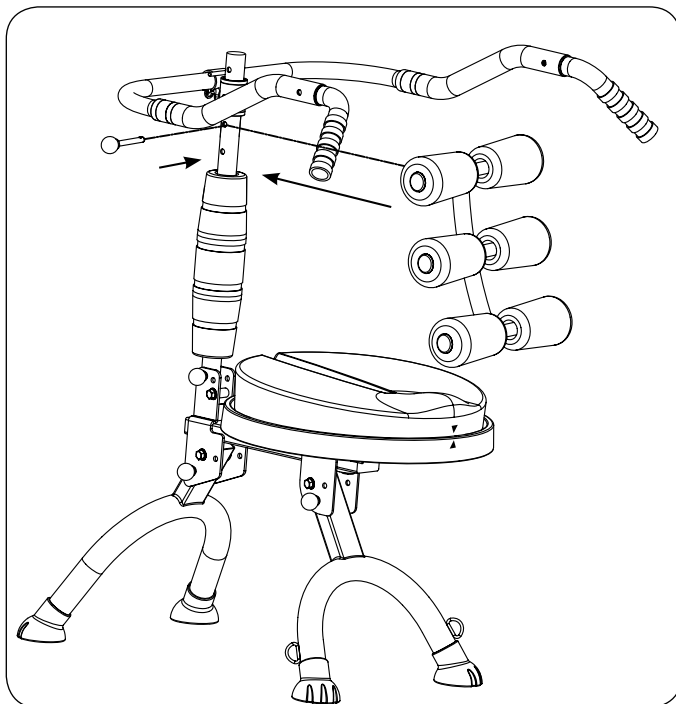

1. Attach the 6 Pack Massage Roller to the Core Support Column then fix it by inserting the 'Insert Pin'.

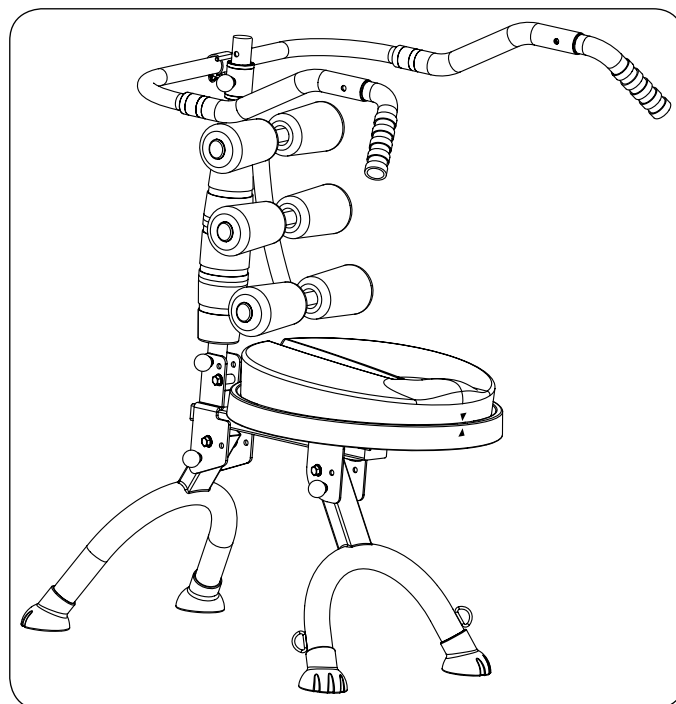

2. Assembly is complete.



The '6-Pack Massage Rollers' are adjustable upward or downward for your body height by simply choosing any one of the various insert holes vertically aligned on the 'Core Support Column'. This adjustability is also extremely useful to offer exercise diversity for many applications.

The '6-Pack Massage Roller System' massages you exactly where you knead it! Feels ABSolutely Terrific!



5. STREET BRAWL

With a wide stance, and feet firmly planted onto the floor, lean forward so your chest is closer to your thighs. By radically pivoting your torso from side-to-side in short little bursts, pretend that you're punching toward the outside of your knee areas in alternating fashion, but be careful you don't knock anybody out. You can lift your chest away from your knees and still maintain your pivoting punching actions to add multiple benefits to this fun and highly productive motion.

This exercise places a lot of emphasis to the abdominals and obliques, plus you'll feel your arms, shoulders and chest getting a terrific workout all at the same time!



### 4. SKATERS

Let's go skating in your living room!

The Armbars can be positioned underneath the arms for Beginners while the overhead position is suggested for more advanced participants. This unique, fun and results-producing motion will activate the swivel-action function of your 'Dynamic Fluidity Seat'. Start slow to get yourself coordinated to the side-to-side motions that mimic skating.

After you're securely seated in the SP firmly grip the Dynamic Grip Handles and begin alternating lateral motions with your legs pivoting your entire body from left-to-right as your buttock/pelvic region swivels in a skating action. As your legs dart out away from your body always lean into the actions with your torso to activate your back, ab and oblique muscles while every muscle in your legs, hips and buttocks are being conditioned at the same time.

Find a comfortable tempo and actually pretend you're in a cross-country skating challenge for distance and/or time. You can stagger the tempo, like performing 1-minute at a moderate speed and range-of-motion, then sprint it out for the next minute. Either way, your body will truly enjoy the creativity and versatility of this unique and highly productive motion that burns fat all over your body. It's amazingly effective!



### Power Resistance Bands Kit

Stretching length (CM)		120	140	160	185
(INCH)		47	55	63	73
Force (N)	Black Band	40	50	68	116
	Green Band	38	46	62	108

#### Hand Grips

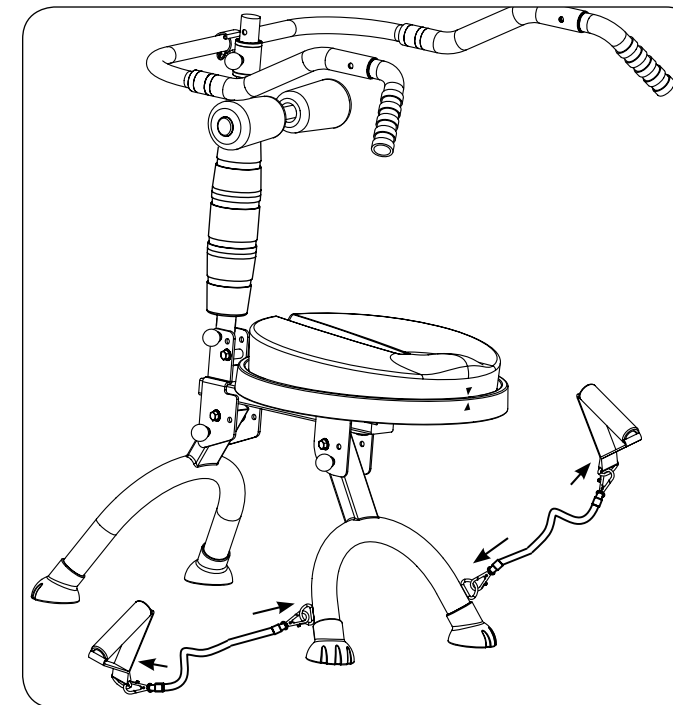

To assemble the Power Resistance Bands and the Hand Grip, take the clip end of a Power Resistance Bands and attach it onto the hook located on the front 'U-Shaped Base Leg'. Attach the other end of the Resistance Bands to the Hand Grip.

#### Ankle Stirrups

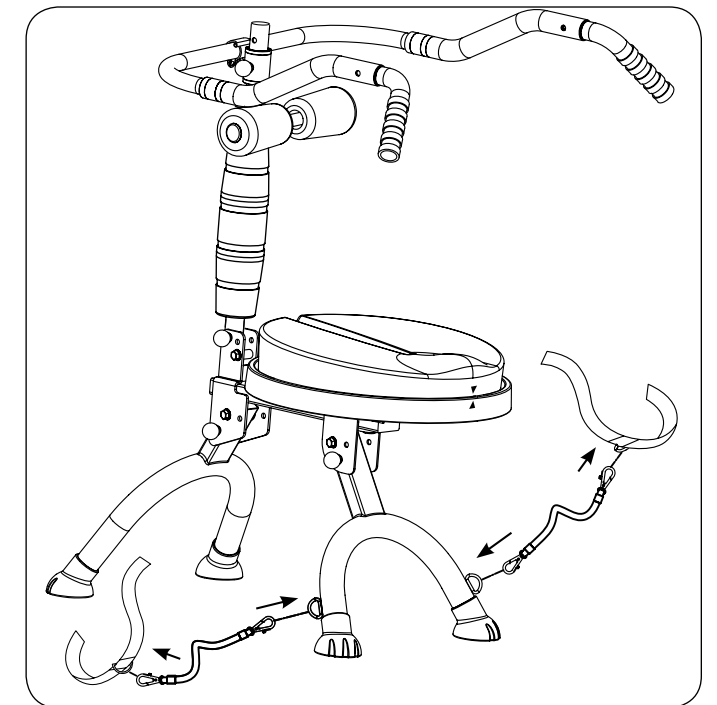

To assemble the Power Resistance Bands and the ankle stirrups, take the clip end of a Power Resistance Bands and attach it onto the hook located on the front 'U-Shaped Base Leg'. Attach the other end of the Resistance Bands to the ankle stirrup.

### Power Resistance Rods

1. Remove the Locking Clip and remove the 'Insert Pin with Hole' from the Core Support Column, then fold it down.

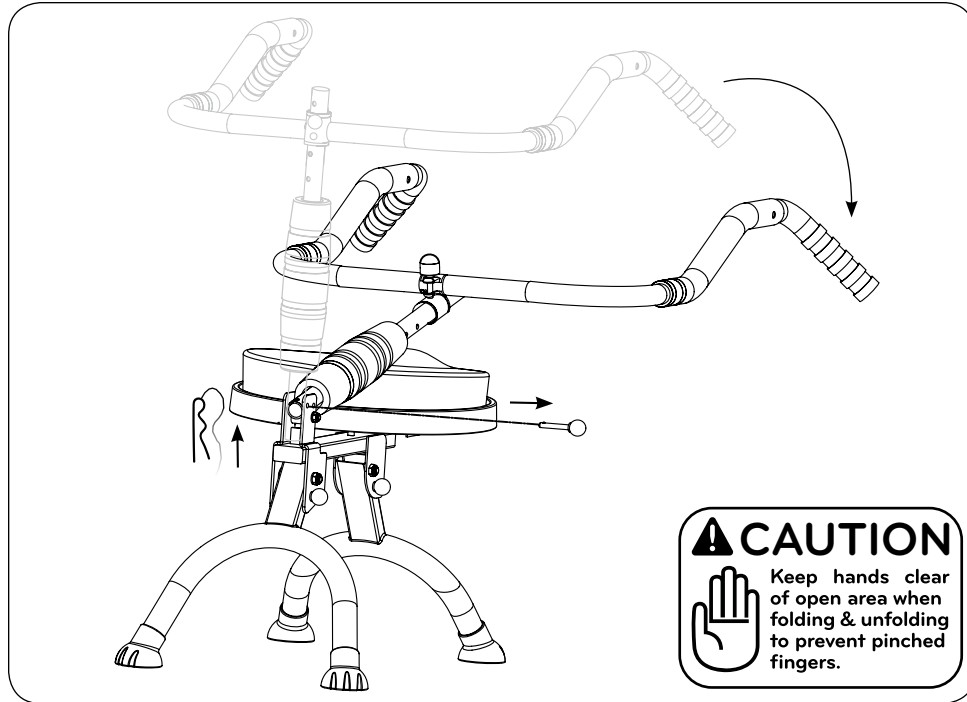

2. Select the level of resistance you need (Yellow, Orange or Red), then insert the Power Resistance Rod, arrow first, into the Core Support Column. Once the Power Resistance Rod is completely inserted into the Core Support Column, turn the Power Resistance Rod clockwise to lock in place as illustrated in figure A.

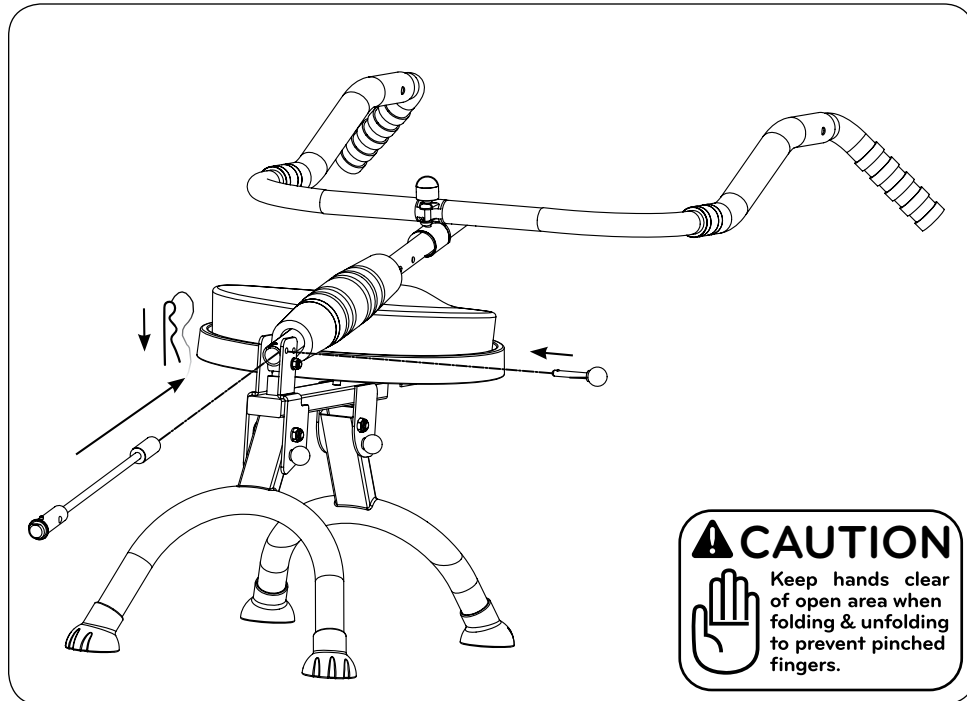

Reposition the Core Support Column to upright position and 'Insert Pin with Hole' to lock into place and secure with the Locking Clip.

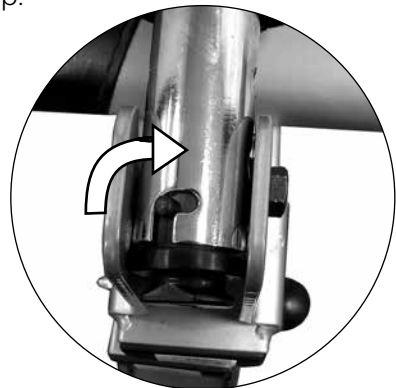

Figure A

### 2. CORE PIVOTS

This is another popular, fun and challenging way for mobilizing your buttock, hip and pelvic region on your AB Doer 360™. After securely assuming the SP start to swivel your Dynamic Fluidity Seat from side-to-side while keeping your feet in the same positions on the floor. As you twist your upper legs, knees and entire waistline will rotate in this beautifully choreographed exercise sequence that conditions all sides of your midsection, inner and out legs, while also mobilizing the muscles of your lower back. At times you will want to increase your pivoting speeds while also increasing your ranges of side-to-motions as your core flexibility and coordination improve. This motion will keep you smiling and always happy!



### 3. BODY BOOGIES

(Circular; Clockwise and Counter-clockwise)

With a wide stance, and feet firmly planted onto the floor, sit upright in the SP then begin to rotate your torso in a circular fashion. Perform 10 circular motions in one direction then switch and rotate in the opposite direction. Start with shorter range-of-motion circular rotations that are slow and controlled, then as you warm up, increase the range-of-motion for each circle and its speed.

This motion is incredibly effective for working ALL the midsection muscles, your spinal and back muscles, abdominal and obliques, all while your legs and upper body receive incredible toning benefits at the same time!



### Some Basic Motions for your AB DOER 360™ machine:

(Please refer to instructional DVD routines (where available) for specific instruction)

#### How to get started:

All movements begin from a seated upright position; this is known as the Starting Position (SP). Place both feet in a wide stance, sit upright with your back pressed against the Massage Rollers, and pull the Contouring Arm Bars firmly underneath your armpits to decompress your spine and maintain an upright posture.

To add even more challenges to your ABDOBIC routines, most motions will also begin and/or transition into positioning the Armbars overhead. This will increase the resistance and condition your muscles to burn more fat.

All motions require varying degrees of body and head motions. Please strive to always maintain a visual focal point as your head moves in different directions during each exercise, obtaining then maintaining 'eye contact' with a fixed object directly in front of you like your TV set, piece of furniture or a stationary item. Maintaining a 'visual focal point' will help to avoid your eyes from transitioning through multiple points of vision and prevent any lightheadedness.

Occasionally, intentionally squeeze the Armbars inward with your hands while holding the Dynamic Grip Handles to engaged your chest, shoulder, and arm muscles. Squeezing the Armbars will be an isometric contraction that contracts additional upper muscles while you're targeting your core midsection region, and more. This is fitness multi-tasking at its best!

Please note that many motions shown in this manual, and also displayed on the instructional DVDs (where available), may have different names and variances in technical instructions and applications, even though these motions are identical or similar to others. Different ABDOBICS instructors may use the names and/or instructional techniques they are comfortable with. Please do not get confused on the possible use of different names and technical instructions. AB Doer 360 is an incredibly diverse technology, with limitless applications and benefits!

Please refer to the instructional guidance on your DVD routines (where available).

### 1. BODY BOBS

(Lateral Bending)

With a wide stance, and feet firmly planted onto the floor, sit upright in the Starting Position (SP) then lean to the right side with your torso. Once you reach a comfortable lateral bend immediately sway all the way over to the left side in a lateral pendulum-like motion and blast the fat off those love handles.

This motion works ALL of the midsection muscles with emphasis to your obliques and lower back!



# AB Doer 360™



Accelerated Results

**Being your ABSolute best . . . It's a Simple "3-Step" Process:**

Achieving a great looking, dynamically strong and healthy body requires a few key principles. When each of these principles are implemented into your routine you will be able to "achieve" then "maintain" results for as long as you remain committed to being a Doer'

**Principle #1: The Correct Tool**

With the technologically advanced AB Doer 360™ you have complete confidence that you have access to a revolutionary exercise system that allows you to condition all regions of your body in ways never available until now. 360™ is your new tool that targets its calorie-burning, muscle-defining benefits across your entire body including your abdominals, love handles, buttocks, hips, thighs and lower abdomen. Additionally, AB Doer 360™ is also terrific for conditioning your arms, shoulders, chest and back, making this a total body system that's extremely simple and fun to use.

**Principle #2: The Correct Instruction & Motivation**

No fitness or body-shaping program or eating plan can provide significant or lasting results if you are under-educated or under-motivated. This is why your AB Doer 360™ system provides you with a library of instructional workout routines that offer diversity and challenge. In addition to your DVD instructions (where available), you also have access to other incredible materials and valuable information that's posted on the Doer website [www.AbDoer.com](http://www.AbDoer.com). Having these resources available 24/7/365 gives you the support you need, when you need it. But the greatest motivator of all is seeing and feeling results. So by committing yourself to the AB Doer 360™ system your results aren't just possible, your results are inevitable!

**Principle #3: The Correct Eating Plan**

Along with your AB Doer 360™, and as part of your Doer Challenge, you are also receiving my Do N.O.T. Diet™ eating plan. N.O.T. represents Nutritional Organizing Technique™, an incredibly simple system that enables you to arrange healthier more balanced meals for accelerated fat-loss while fueling your body with enhanced levels of energy.

By committing yourself to the AB Doer 360™ system your results aren't just possible, your results are inevitable!



NOTES:

- \* Active Rest Day "Off" does not mean you do nothing. Instead, I recommend you select activities that are fun yet challenging like walking, jogging, running and cycling (outdoor or on a treadmill), dancing, yoga and/or Pilates, skating, hiking, or sports activities like tennis, golf, volleyball, and others known for their aerobic 'calorie-burning' 'muscle-toning' benefits. Active Rest Days do not need to be hard or high impact. Instead, activities performed on these days are intended to add variety and to keep your metabolism revved up, 24/7.
- \* Active Rest Days can also include relaxation and recovery practices like massage, sauna, flexibility motions, and other relaxation techniques that limber up any stiff or tense muscles and joints, reduce stress and calm your mind. You can also perform the 'Core Mobility' DVD (where available) back stretching and spinal mobilizing' routine multiple times daily to stretch and massage your back, pelvic, hip and leg muscles. This DVD routine (where available) is designed to reduce stress, increase blood flow, loosen up stiff and stubborn muscles, prepare you for upcoming activities, and assist in post-activity recovery. The 'Core Mobility' DVD (where available) can be applied with either the '2-Pack' or '6-Pack' Massage Roller systems.
- When following any one of the ABDOBICs routines, and provided you have become conditioned, you can prolong the durations of your workout times; Beginner, Intermediate and/or Advanced, by simply backtracking the DVD (where available) to its beginning after the completion of a circuit, and perform the same routine all over again. The break in the action to re-set the circuit is necessary to give you a short 'time-out' so you can prepare your mind and body for another fat-burning and muscle toning circuit, and perhaps get a drink of water. You can also perform two or more routines in succession like Circuit 1 is Advanced ABDOBICs followed by Circuit 2 with the Intermediate routine. It is recommended to strive to perform two circuits of the Advanced routine, while some Doers perform three circuits. As an example, the workout times for the Advanced ABDOBICS routine can be increased from (approx) 20 minutes to 60 minutes by simply performing two (2) extra circuits, or three (3) total circuits. You can combine any of the three routines to increase duration and intensities. Now that's what being a Doer is all about!
- Always eat healthy, and follow the guidelines listed in the Do N.O.T. Diet™ eating plan.

It feels terrific to be in great shape! AB Doer 360™ makes it fun, easy and always motivating to accomplish my goals!



AB Doer 360™ challenge is a dynamic process. You'll always remain motivated, challenged and ever improving through this creative and diverse 'success-proven' system. As the weeks progress you will become stronger, leaner and more coordinated, all while burning off excess fat and reshaping your muscles.

The AB Doer 360™ workout system is designed to burn off excess calories, tone and strengthen your muscles and also assist you with quicker, more complete post-workout recovery times. The 'Weekly 'Doer Challenge' Workout Planner' chart below illustrates how a weekly schedule may be applied throughout the '8-Week Phase'. Please allow yourself ample time to condition yourself to this pacing while making adjustments that fit into your personal lifestyle and other responsibilities that require your time and energy. Remember, the key is to success is to recover from your exercise.

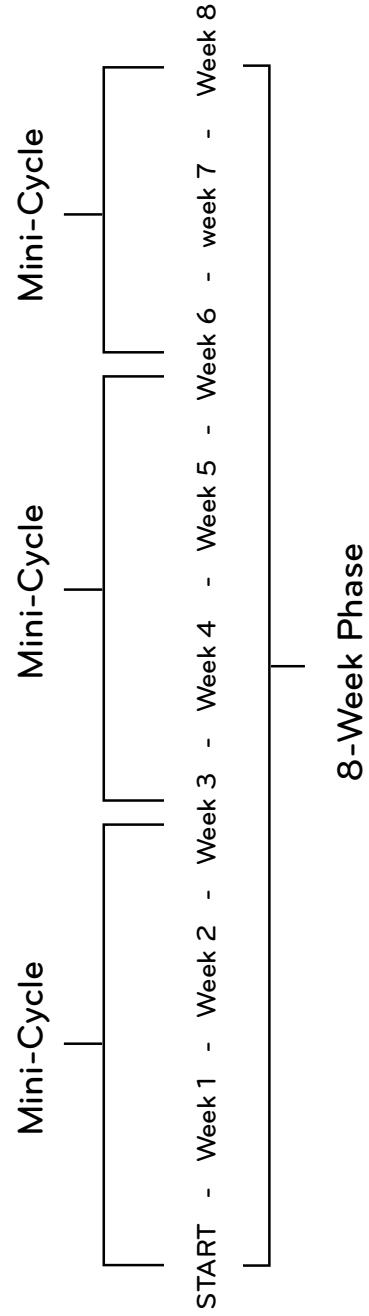

Weekly 'Doer Challenge' Workout Planner

Weeks 1-2		Monday	Tuesday	Wednesday	Thursday	Friday	Saturday
Beginner	Beginner	Beginner	Beginner	* Active Rest Day	Beginner	Beginner	* Active Rest Day
Abdobics	Abdobics	Abdobics	Abdobics	Abdobics	Abdobics	Abdobics	Abdobics
Weeks 3-5		Intermediate	Beginner	* Active Rest Day	Intermediate	Intermediate	* Active Rest Day
Abdobics	Abdobics	Abdobics	Abdobics	Abdobics	Abdobics	Abdobics	Abdobics
Weeks 6-8		Advanced	Advanced	* Active Rest Day	Advanced	Intermediate	* Active Rest Day
Abdobics	Abdobics	Abdobics	Abdobics	Abdobics	Abdobics	Abdobics	Abdobics

Self-Assessment Exams - Personal Accounting:

It's extremely important, and motivating, that you take the time to really get to know yourself. Know is the time to be honest with yourself, and take full account. The following self-assessment exams are intended to collect personal information on your current status, and then are used later on to chart your progress. Journaling your measurements in this fashion allow you to keep personal inventory of yourself over the weeks, months and years ahead.

**Body Measurements:** Take a few moments to measure your body using the Measurement Chart provided below. Also register your body weight by standing unclothed on a reliable scale. Perform these measurements on the first day of your Doer Challenge then re-measure yourself once per week to chart progress. The results week to week will be extremely motivating!

**Take 'Before' Photos:** Another great motivator is by snapping some pictures of yourself before you begin your Doer Challenge, and at periodic times thereafter. These "before" pictures prove to be a valuable motivating factor for a variety of reasons. Remember, these measurement and photos are your private property, so snap pictures with as little clothing on so you can see where you need to tighten up, as clothing will hide much of what you'll be trying to reduce. Although you might cringe at the sight of a tape measure, scale and now a camera, I encourage that you snap these photos so you can make comparisons of yourself and to fully comprehend just how real your results appear in the upcoming weeks and months ahead!

## John Abdo's "Ab-Do's!"

- Always sit upright on the AB Doer 360™ centering your buttocks directly on top of the Dynamic Fluidity Seat, and placing your back against the massage roller.
- Follow any one of the instructional video routines that compliment your level of fitness. Always pace yourself even if the talent in the DVD routines (where available) are moving at quicker paces, or motioning through wider ranges of motions than you are capable. Be patient. Take your time. Learning new skills; especially those that require coordination, flexibility and balance, requires time and becomes easier with practice.
- To ensure stability, support and balance, securely place your feet flat onto the floor at a shoulders' width stance or wider, unless otherwise recommended for certain motions.
- Many components on the AB Doer 360™ offer adjustability:
  - The Massage Roller adjusts up and down. For best results, position it approximately between your shoulder blades, or any position you find most comfortable. You can also change positions on occasion to massage different portions of your back.
  - The Arm Bars are also adjustable up and down along the Core Support Column. Once you're properly seated onto the AB Doer 360™, pull the Arm Bars underneath your armpits and secure a firm grip with both hands onto the Dynamic Grip Handles. Please note the Arm Bars are mobile, as they are designed to rotate up-n-down, and THEY DO NOT LOCK INTO PLACE.
  - By firmly holding the Arm Bars underneath your armpits you automatically reduce the pressure, or compression exerting downward onto your spine. The Arm Bars also support your back and spine unique to Ab-Doers' patented technology. As the Arm Bars are attached to the Core Support Column, you can motion your body in forward, backward, side-to-side and even circular patterns. It's limitless what you can do with your AB Doer 360™!
- To begin any session, just move slowly and easily. Feel your body out with the new patterns of motion. Short slower movements will begin to limber up stiff or unconditioned waistline and back muscles. As you advance your level of conditioning you will naturally move through wider ranges of motion while increasing the pace and tempo of your movements. But please note that many AB Doer 360™ motions are performed slowly, controlled and deliberate, like performing many Pilates or Yoga motions; a perfect mixture of all applications.
- When you fatigue during an AB Doer 360™ session, simply:
  - o Slow down the speed of each movement, or
  - o Reduce the range of motion, or
  - o Transition to another movement, or
  - o Stop, you've had enough – great job. You finished your workout today!
- Always wear comfortable, supportive [non-slip] clothing while exercising. Empty your pockets and remove any belts or other objects that may interfere with any of the motions or poke your body while bending. Baggy clothes can bunch and chafe, and can even get in the way of your workout. Make sure you're also wearing supportive shoes that have non-slip soles, and that your shoelaces are tied firmly and are not hanging loosely.
- An impressive feature of the AB Doer 360™ is that it offers a terrific aerobic workout. This is because you can exercise for longer durations. As you fatigue from one movement you simply transition to another. This way you can keep right on moving to constantly burn more calories and tone your muscles. It's a remarkably unique combination of both Aerobic and Anaerobic exercise; referred to as 'fat-burning' and 'muscle toning' respectfully!

## John Abdo's "Ab-Do's!" continued

- In addition to burning fat and toning muscle, you'll quickly notice how effective AB Doer 360™ is at loosening up stiff, sore or stubborn back muscles. And as your waistline shrinks you'll feel more flexible and less stressed. AB Doer 360™ is the perfect warm-up and cool-down for work and play.
- If, at first, the movements on your AB Doer 360™ seem a bit awkward, don't get alarmed; you're not alone. Many of the AB Doer 360™ motions are athletic in nature, helping you to also boost your degrees of coordination which is the communication between your brain, all your muscles, and your metabolism. The more coordinated you become the better you can move and control your body. AB Doer 360™ technology doesn't move you, you move AB Doer 360™; so you'll always be in control. AB Doer 360™ supports and guides you throughout every position, whether your body is moving forward, backward, side-to-side and even in circular patterns. Be creative, have fun, and enjoy unique, productive workouts!

## John Abdo's "Ab-Don'ts!"

- Don't place your feet together unless recommended for certain motions. Your feet must be positioned in a wide, flat stance firmly planted onto the floor.
- Don't perform any fast, jerky or explosive movements until your muscles have had a chance to adjust to many of the AB Doer 360™ motions and routines.
- Don't perform extreme ranges of motion until your midsection muscles, back and spine have become more flexible and coordinated.
- Don't count repetitions. Rather, treat your AB Doer 360™ workouts like other aerobic activities. You wouldn't count steps on a treadmill or stepper, or the number of times you punch or kick a heavy bag. Instead, just have fun and "dance" from a seated position.
- Don't think about resistance. The first reaction many have when using AB Doer 360™ is that it seems too easy; but that's exactly what you're supposed to feel. The logical comparison is like walking or boxing while holding onto 'light' (not heavy) dumbbells. Even though the dumbbells are 'light' in weight, the repetitive action during a long walk or a boxing session continuously burns calories and tones muscles without increasing muscle size.
- Don't exercise intensely every day. This is counter-productive and decreases your body's ability to recover properly. The key is to exercise then make certain you're recovering between sessions.
- Don't eat junk food. Be wise in your selection and consumption of foods. Your body must be fed nutritious foods to enable your metabolism to burn fat and repair and recharge your muscles, bones, nerves and organs.
- Avoid consumption of alcohol, drugs or smoking prior or during use.
- Don't close your eyes while exercising or perform your routines in a poorly lit or dark room.
- Never stand or kneel on this product.
- Carefully watch where and how you position your body, face, hands, fingers, feet and legs during assembly, all height adjustments, affixing and/or removing any of the items, or transporting to use in another location or store away.
- Don't ever use your AB Doer 360™ as a clothes hanger!

# AB Doer 360<sup>TM</sup>



Distributed by:

Thane Canada Inc.  
Mississauga ON L4W 5M6,  
Canada  
[www.thane.ca](http://www.thane.ca)

Thane USA, Inc.  
Canton OH 44718, U.S.A.  
[www.thane.com](http://www.thane.com)

Thane Direct UK Ltd  
London EC1Y 8NA, UK  
[www.thane.tv](http://www.thane.tv)

Danoz Direct Pty Ltd  
Alexandria NSW 2015,  
Australia  
[www.danoz.com.au](http://www.danoz.com.au)

Operadora Ainoa, S.A.P.I. DE C.V.  
C.P 02480, México. D.F.  
[www.mejorcompratv.com](http://www.mejorcompratv.com)

TVINS  
211 18 Malmö, Sweden  
[www.tvins.com](http://www.tvins.com)

© 2017 Thane IP Limited.  
MADE IN CHINA

"Thane", "AB Doer", "AB Doer 360" and related logos and variations are trademarks or registered trademarks, in Canada and/or other countries, of Thane IP Limited and/or its affiliated companies.

AB Doer 360 MNL ENG HSN RO 170323