

Motorcycle Rear Paddock Stand

KCT

MBS101

Assembly Instructions

Imported by:

KCT Direct
Glebe Farm,
Old London Road,
Copdock, Ipswich,
Suffolk, IP83JN,
United Kingdom



**Max Weight
385kg**

Please read the following installation instructions carefully.

We accept no liability for damage to property and/or personal injury resulting from improper or faulty installation or use.

Please check the correct function before each use.
Re-tighten the screws if necessary.

Subject to technical changes, printing errors and mistakes.



**DO NOT START THE MOTORCYCLE ON THE STAND
DO NOT SIT ON THE MOTORCYCLE WHEN IT IS LIFTED BY THE STAND**

Parts list

Required tools - Open ended spanner SW17 & 6mm hexagon key.

Parts

A. Handle Frame	x1
B. Wheel Frames	x2
C. V Type Adapters	x2
1. Bolts	x2
2. Lock Nuts	x2
3. Knobs	x2
4. Washers	x4

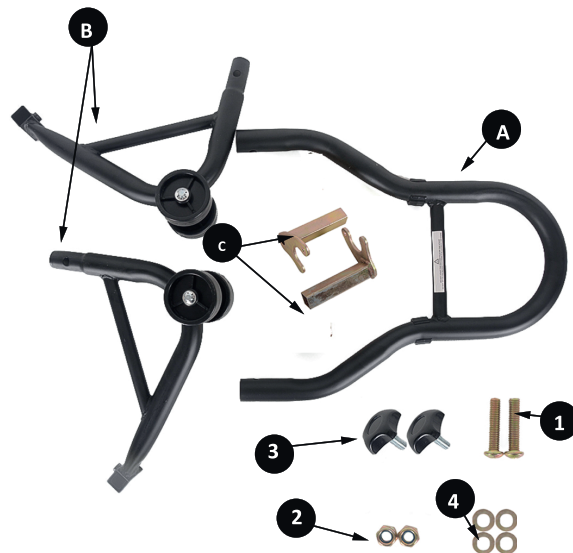

Assembly

Step 1: Mount the Wheel Frames (B) to the Handle Frame (A). Use the Bolts (1) and the Nuts (2) and Washers (4) for this purpose.

Step 2: Connect the V type adapters (C) to the Wheel Frames (B) using the Knobs (3).

