

VORSPRUNG®



User and Installation Manual

Model No.:
20284 / 20285



CONTENTS

1. Safety Information	03
• Important safety instructions	03
2. Product Introduction	04
• 2.1. Product Appearance	04
• 2.2. Parameter table	05
• 2.3. Features	05
• 2.4. Protection Functions	06
3. Installation Instructions	07
• 3.1. Installation Considerations	07
• 3.2. Minimum Installation Requirements	07
• 3.3. Position	08
• 3.4. Height	08
• 3.5. Power Supply	08
• 3.6. Accessories List	08
• 3.7. Installation Step	09
• 3.8. SIM Card Installation	14
4. Operating instructions	14
• 4.1. Buttons On Charger	14
• 4.2. Buzzer	14
• 4.3. LED Lights Display	15
• 4.4. Firmware Update via OCPP Server	18
5. Warranty	19
6. Manufacturer self-declaration	19
7. OCPP EV Charger Network Configuration Guideline	19
• 7.1. Enter Wi-Fi Configuration Mode	19
• 7.2. Enter the configuration interface	19
• 7.3. Network configuration	21
• 7.4. RFID Configuration	24
• 7.5. Other Configuration	25
• 7.6. Upload CA-Certificate	27
• 7.7. Password Configuration	28
• 7.8. WPS Connection Method	29
• 7.9. Exit Web Configuration Mode	30
• 7.10. Monta App Set-up & Configuration	30

1. Safety Information

Installation of this Unit must be Performed by a Certified Engineer.

Important Safety Instructions

This document contains important instructions and warnings that must be followed when installing and maintaining the EV Charger.

Warning

- ⚠ Read this entire mandatory document before installing or using the EV charger.
- ⚠ This device should be supervised when used around children.
- ⚠ The BCP series EV Charger must be grounded through a permanent wiring system or an equipment grounding conductor.
- ⚠ Do not install or use the EV Charger near flammable, explosive, harsh, or combustible materials, chemicals, or vapors.
- ⚠ Use the EV Charger only within the specified operating parameters.
- ⚠ Never spray water or any other liquid directly at the wall mounted EV Charger. Never spray any liquid onto the charger handle or submerge the charger handle in liquid. Store the charger handle above the ground to prevent unnecessary exposure to contamination or moisture.
- ⚠ Stop using and do not use the EV Charger if it is defective, appears cracked, frayed, broken, or otherwise damaged, or fails to operate, or continue operation.
- ⚠ Do not attempt to disassemble, repair, tamper with, or modify the EV Charger. The EV Charger is not user serviceable. Contact us for any repairs or modification.
- ⚠ Transporting the EV Charger; handle with care. Do not subject it to strong force or impact or pull, twist, tangle, drag, or step on the EV Charger, to prevent damage to it or any components.
- ⚠ Do not touch the EV Charger's end terminals with sharp metallic objects, such as wire, tools, blades, or needles.
- ⚠ Do not forcefully fold or apply pressure to any part of the EV Charger or damage it with any sharp objects.
- ⚠ Do not insert any foreign objects into any part of the EV Charger.
- ⚠ Use of the EV Charger may affect or impair the operation of any medical or implantable electronic devices, such as an implantable cardiac pacemaker or an implantable cardioverter defibrillator. Check with your electronic device manufacturer concerning the effects that charging may have on such electronic devices before using the EV Charger.

Cautions

- ⚠ Do not use private power generators as a power source for charging.
- ⚠ Incorrect installation and testing of the EV Charger could potentially damage either the vehicle's Battery and/or the EV Charger itself. Any resulting damage is excluded from Vorsprung Vehicle Limited Warranty and the EV Charger Limited Warranty.
- ⚠ Do not operate the EV Charger in temperatures outside its operating range of -25°C to +55°C.
- ⚠ Any adaptors or conversion adapters are not allowed to be used.
- ⚠ Any cord extension sets are not allowed to be used.

Notes

- ⚠ Ensure that the EV Charger's charging cable is positioned so it will not be stepped on, driven over, tripped on, or subjected to damage or any tension.
- ⚠ Do not use cleaning solvents to clean any of the EV Charger's components. The outside of the EV Charger, the charging cable, and the connector end of the charging cable should be periodically wiped with a clean dry cloth to remove accumulation of dirt and dust.

Be careful not to damage the circuit board when removing the power entry.



2. Product Introduction

2.1. Product Appearance



1	Emergency Button Switch (When the button is pressed, the EV Charger will stop. Rotate the button pop-up to reset.)
2	Function test button (For WPS connection, and leakage test.)
3	RFID
4	Type 2 socket
5	LED light
6	Type 2, 5m Charging Gun

2.2. Parameter table

Wallbox Models	20284	20285
		
Maximum Power	7.4KW	
Input voltage/Output voltage	AC230 1-Phase	
Input frequency	50Hz/60Hz	
Tethered/Socket	Tethered	Socket
Meter	Metering Chip	
Display	LED Lights	
Frequency	50Hz/60Hz	
Rate Charging Current	6-32A	
Cable Length	5M	N/A
Standby Power Consumption	2W	
Operating Temperature	-25°C – 55°C	
Storage temperature	-40°C – 85°C	
Operating Humidity	5%-95%	
IP Protection	IP65	IP55
Safety Protection	Leakage Protection, Over Current Protection, Ground Protection, Over Voltage Protection, Under Voltage Protection, Contactor Adhesion Protection, Neutral and Live Wire Reverse Connection Protection, Over Temperature Protection, CP Signal Abnormal Protection, Lightning Protection	
Operating Altitude	≤2000m	
Charger Dimension	380mm*169mm*151mm(H*W*D) With junction box: 380mm*169mm*201mm(H*W*D)	
Gross Weight	7KG	5KG
Leakage Detection	TYPE A+DC6mA leakage sensor built-in	

2.3. Features

- Connectivity: Ethernet and WIFI connection
- Opened Up Detection: Once the charger is opened up, the charger stops charging and make alarm.
- App Remotes: Remotely control the charger and have the charging history.
- Full Protection: For people's safety
- IP65 level protection
- Leakage Protection: with Type A sensor + DC6mA sensor
- Temperature Protection: Stops operating once over temperature.
- WPS WIFI Connection: Faster connection
- Operating Temperature: -25°C~+55°C
- **Note:** To connect refer to point 7. Network Configuration Guideline (page 27).

Wi-Fi

Operating Frequency Range	2412 - 2484MHz
Wi-Fi Protocols	IEEE 802.11 b/g/n
Channels	14
TX Power	18.5~20.5dBm
EIRP	0.459
TX bandwidth	20MHz/40MHz
Modulation type	OFDM & DSSS
Transmitting Duty Cycle	10%

BlueTooth BLE

Sensitivity @30.8% PER	-93 dbm
Co-channel C/I	+10dB
RF Power Control Range	-12 ~ 9dbm

4G

Frequency Bands:	LTE-FDD:B1/B2/B3/B4/B5/B7/B8/B12/B13/B18/B19/B20/B25/B26/B28 LTE-TDD: B38/B39/B40/B41
Data:	LTE-FDD: Max. 150 Mbps (DL)/Max. 50 Mbps (UL) LTE-TDD: Max. 130 Mbps (DL)/Max. 30 Mbps (UL)
Output Power:	LTE-FDD: Class 3 [23 dBm ±2 dB] LTE-TDD: Class 3 [23 dBm ±2 dB]

2.4. Protection Functions

With full protection to avoid all kinds of charging safety hazards, it will automatic power off after the vehicle is fully charged, to protect the car battery and prolong the working life.



Leakage Protection



Over Current Protection



Ground Protection



Over Voltage Protection



Under Voltage Protection



Contactor Adhesion Protection



Neutral and Live Wire Reverse Connection Protection



Over Temperature Protection



CP Signal Abnormal Protection



Lightning Protection



Warning

- ⚠ Normally, the earth wire should be properly connected, otherwise the EV charger will not work.
- ⚠ For situation where there is no earth connection, in order to enable the EV Charger to operate, it can be set via APP to turn off the earth detection and it will work, but it will reduce to the leakage protection safety level.
- ⚠ This series of AC EV charger must be grounded via a permanent electrical system or equipment grounding conductor.
- ⚠ Note: Please consult your local electrician for the AC EV charger current.

3. Installation Instructions

3.1. Installation Considerations

- Here are some additional guidelines
- Conduit needs to be metal and flame retardant.
- Use an appropriate circuit breaker.
- To keep the housing weatherproof, use cable glands.

3.2. Minimum Installation Requirements

Installation of the wall charger requires that you:

- Calculate the existing electrical load to determine the maximum operating current.
- Calculate the distance to ensure minimal voltage drop.
- Obtain any necessary permits from the local authority that has jurisdiction and confirm that the follow-up inspection has been scheduled by a qualified electrician after the installation is complete.
- Use only copper conductors.
- Use copper wire that meets the specifications of local wiring regulations. The selected cable must be capable of withstanding continuous loads of up to 40A at all times. The selected circuit protection device must incorporate an appropriate wall-mounted residual current device (RCD) and corresponding electrical load over current protection.

3.3. Position

- Ensure that the parking position is within range of the charging cable.
- There is enough clearance for the charging cable to wrap around and the charging handle can be comfortably positioned on the side of base.
- If installed in an enclosed garage, choose to install on the side of the EV charger slot.
- For outdoor installations, waterproof protection is recommended but not mandatory.
- Install in a well-ventilated space. Avoid installation in enclosed boxes or close to high power appliances.

3.4. Height

- Maximum height (indoor and outdoor): 60 inches (1.5 m)
- Recommended height: 47 in (~1.2 m)
- Minimum outdoor height: 24 in (0.6 m)
- Minimum interior height: 18 inches (0.45 m)

3.5. Power Supply

230V single-phase power supply

- For single-phase EV charger, a single-phase wire (L), Neutral and earth wire must be connected. The phase voltage between the Line and Neutral wires should be 230V.



3.6. Accessories List



EV charger

X1



Mounting bracket

X1



RFID card

X2



M32*1.5 cable gland

X1



M6*8 screws

X4



8*40 socket head screws and anchorings

X6



Water-proof cover

X1



Position template

X1

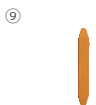

Plastic lifter

X1

Note: Card type supported by RFID: RF card ISO14443 Type A, MIFARE® ONE (MF1) card, with the read-write frequency of 13.56MHz±7K.

3.7. Installation Step

3.7.1. Step-by-step Installation Instructions (bottom entry wiring)

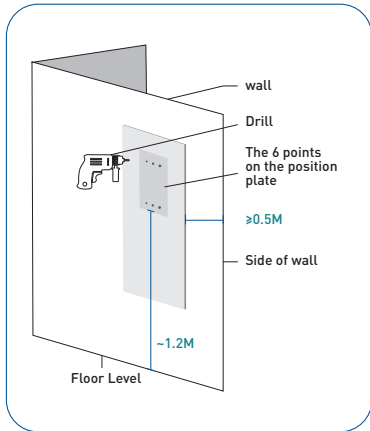

Step 1

Position

The bottom of the ⑧ positioning plate is 1.2 m away (recommended), if the EV charger is installed close to the edge of the wall, the positioning plate should be more than 0.5 m away from the edge of the wall.

Drilling pilot holes

Drilling the holes according to the instruction on the Position template for different installation and wiring ways.

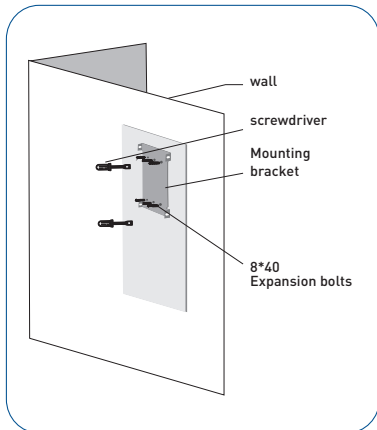

Step 2

Install the Mounting bracket

Put the 8*40 Socket head screws' anchoring into the holes, and use a screw driver make the 6pcs 8*40 Socket head screws to fix the Mounting bracket on the wall .

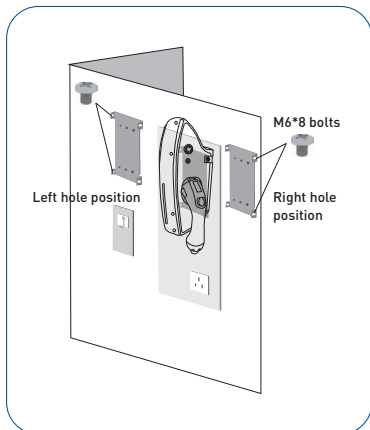

Step 3

Install the EV Charger to the mounting plate

Align the side hole of EV charger to the panel's side holes.

Installation

Use the 4pcs M6*8 screws to fix the EV charger to the mounting plate as picture shows (Screws torque 1.5NM-2.0NM).

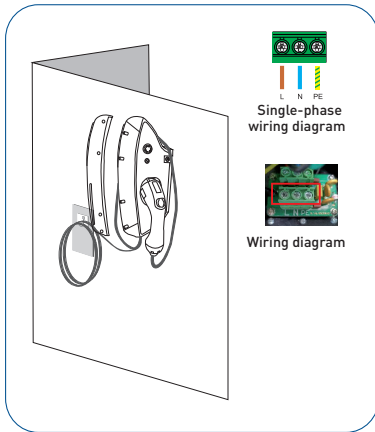

Step 4

Wiring

Note: It is the qualified installer's responsibility to identify whether additional grounding is required to ensure that local regulations are met. Grounding must be installed at the power source and not at the cable entry to the EV Charger.

As the picture on the left shows, use a screwdriver to loosen the screws on the EV charger cover. Wire the cable according to the terminal.

Note: The torque applied to the screws should be 1.8N-m to 2.2N-m

3.7.2. Step-by-step Installation Instructions (rear entry wiring)

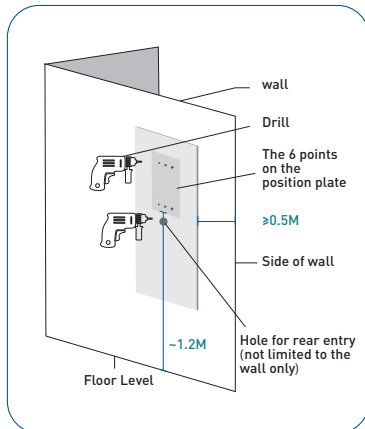

Step 1

Position

The bottom of the ⑧ positioning plate is 1.2 m away (recommended), if the EV charger is installed close to the edge of the wall, the positioning plate should be more than 0.5 m away from the edge of the wall.

Drilling pilot holes

Drilling the holes according to the instruction on the Position template for different installation and wiring ways.

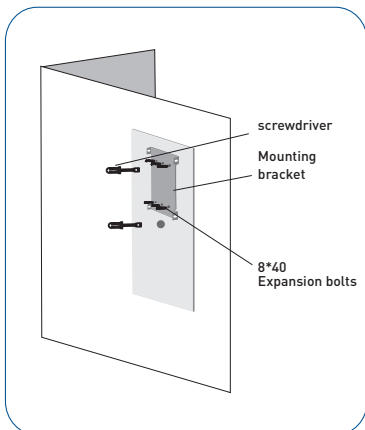

Step 2

Install the Mounting bracket.

Put the 8*40 socket head screws' anchoring into the holes, and use a screw driver make the 6pcs 8*40 Socket head screws to fix the mounting bracket on the wall .

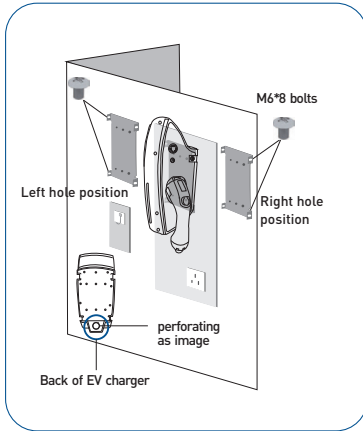

Step 3

Install the EV Charger to the mounting plate.

Find the hole for cut out on the back of EV charger.

Use the 4pcs M6*8 screws to fix the EV charger to the mounting plate as picture shows (Screws torque 1.5NM-2.0NM).

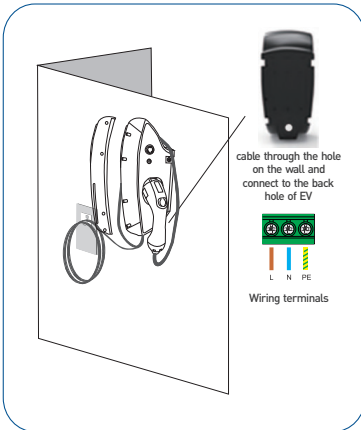

Step 4

Wiring

Note: It is the qualified installer's responsibility to identify whether additional grounding is required to ensure that local regulations are met. Grounding must be installed at the power source and not at the cable entry to the EV Charger.

As the picture on the left shows, use a screwdriver to loosen the screws on the EV charger cover. Wire the cable according to the terminal.

Note: The torque applied to the screws should be 1.8N-m to 2.2N-m

3.7.3. Step-by-step Installation Instructions (top entry wiring)

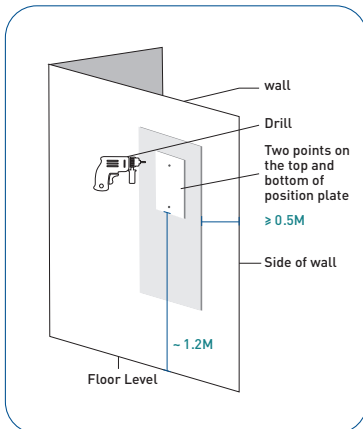

Step 1

Position

The bottom of the ⑧ positioning plate is 1.2 m away (recommended), if the EV charger is installed close to the edge of the wall, the positioning plate should be more than 0.5 m away from the edge of the wall.

Drilling pilot holes

Drilling the holes according to the instruction on the Position template for different installation and wiring ways.

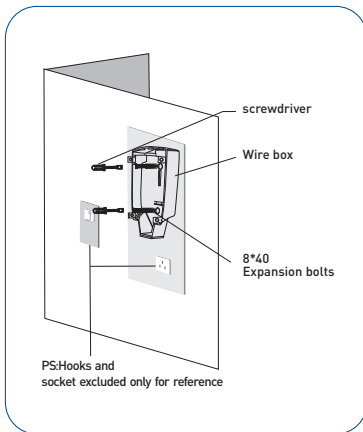

Step 2

Fix the wire box

Put the 8*40 flat head screws anchoring into the holes and use a screw driver make the 2pcs 8*40 flat head screws to fix the Wire box Mounting Template on the wall.

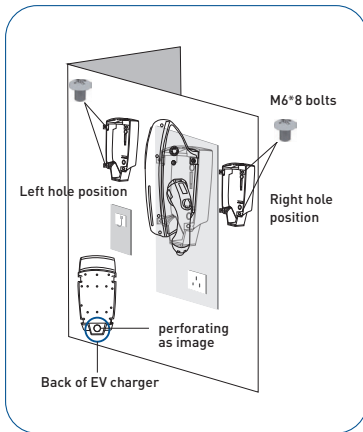

Step 3

Cut out on the back of the EV charger.

Find the hole for cut out on the back of EV charger.

Use the 4pcs M6*8 screws to fix the EV charger to the mounting plate as picture shows (Screws torque 1.5NM-2.0NM).

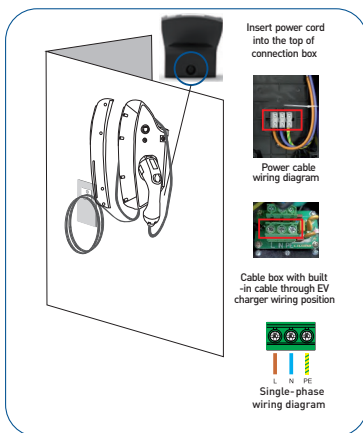

Step 4

Wiring

Note: It is the qualified installer's responsibility to identify whether additional grounding is required to ensure that local regulations are met. Grounding must be installed at the power source and not at the cable entry to the EV Charger.

As the picture on the left shows, use a screwdriver to loosen the screws on the EV charger cover. Wire the cable according to the terminal.

Note: The torque applied to the screws should be 1.8N-m to 2.2N-m

3.7.4. External Meter Installation

Warning

- Do not connect the power cord before reading and fully understanding all the concepts introduced in this section. If you are not sure whether the type of power supply on the repair panel is available, please consult an electrician for assistance.
- Be careful of electric shock! Before use, use a voltmeter to confirm that there is no voltage on the power supply line or terminal to ensure that the power has been cut off.
- Disconnect the power supply at home, and find the neutral wire and the live wire at the entrance to the house
- According to the wiring figure, the live wire and the neutral wire are respectively connected to the power grid through cables that support a current of more than 32A, so that the connection between the power meter and the power grid is completed.
- According to the wiring figure, connect the live wire and neutral wire to the interfaces be reserved in the charger respectively through the cables that support more than 32A , so that the meter is connected.
- The AB interfaces on the meter needs to be connected to the AB interfaces in the charger PCB Via a cable that supports 485 communication.
- The ground wire of the grid needs to be connected to the ground wire interface which is reserved in charger.
- The meter has been configured to fit the charger by default, please do not change the configuration. Please contact us for technology support if you are going to install meters.

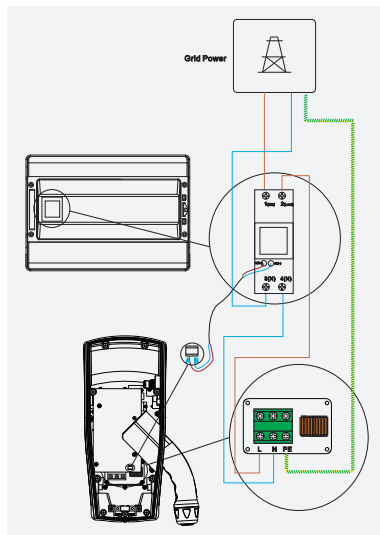

Single Phase

3.7.5. Set the Operating Current

- After installation, users can set the maximum operating current of the EV charger in the APP, Please refer to APP manual for details.

3.7.6. Reinstall the Sealing Cover and Turn on Power

- ① Use a screwdriver to lightly secure the sealing cover by installing only the top screws at (1.5NM-2.0NM)torque.
- ② After sealing cover is fitted, put the fascia on and fix it on the sealing cover.
- ③ If you need to open the front cover, change the internal settings, please use the plastic lifter to unclench along the edge of the cover.
- ④ Recommend to install a circuit breaker 40A/2P 30MA.



3.8 SIM Card Installation

- Note: If you need to use 4G mode, please install a Micro SIM card

4. Operating instruction

4.1. Buttons On Charger

- Emergency stop button

Press	Stop the charging
Button ejecting	Fixing faults
Button ejected	In operating

- Function test button









Press	Leakage test
Long Press	WPS mode works, search for WPS and pair.

- Rest button on PCB Long press for 5s Reset the charger password (Wi-Fi Ap Password and OCPP configuration Password)
- To restore the charger to be default settings, press emergency stop button and long press reset button for 20s to achieve.
- Press emergency button while powering on again the EV charger. Then start the OCPP configuration process.





4.2. Buzzer







Swipe the RFID card to start the authentication successfully	One Short Beep
Swipe the RFID card to stop the authentication successfully	Two Short Beeps
RFID card authentication failed	Five Short Beeps
Enter server configuration mode	One Long Beep
Server parameters are configured successfully	One Long Beep
Server parameter configuration failed	Two Short Beeps
Leakage test in progress	One Long Beep







4.3. LED Lights Display

Normal Status				
LED Indicator	LED Status	Status Description	Potential Cause	Solution
	Lights OFF	No power supply	No power	Check power source
	The green lights light up in sequence from top to bottom, then the yellow and red lights light up in sequence until the first green light blinks	Charger Power ON self test		
	The first green light fast blinking (ON for 0.25 seconds, OFF for 0.25 seconds)	Enter WPS configuration	In WPS configuration status	Recheck configuration
	The first green light slow blinking (ON for 1 second, OFF for 1 second)	Network is not connected	Wi-Fi connection failure or wrong password	1.5G or WPA 2_Enterprise is not available for charger 2.Ensure password is correct 3.Restart the APP
	The first light is in the green breathing light state	Standby in the default state		
	The first light is in the blue breathing light state	Standby in OCPP mode (Wi-Fi, Ethernet, 4G)		
	The first green and the last green lights slow blinking. (ON for 1 second, OFF for 1 second)	The charger is reserved		
	The 1-6 green lights ON, brightness decreases from top to bottom	Charger authorized, waiting for the Charging Connector plug in		

Note : LED light in blue for standby status is only adapted to the charger which is produced after June 2024.

Normal Status				
LED Indicator	LED Status	Status Description	Potential Cause	Solution
	Green lights up and down	The Charging Connector is plugged in, waiting for RFID card authentication		
	Green lights end in the middle	Waiting for the car start to charge		
	Green lights extend from the middle to the ends	Charging		
	All green lights ON	Charging finished		
	Yellow lights flashing	Charger is remotely disabled or not registered	Charger is not configured	Configure the charger

Fault Status				
LED Indicator	LED Status	Status Description	Potential Cause	Solution
	All lights strobe (4 times per second)	Contact failure	Contact adhesion or tripping	Check whether the vehicle charging module is normal
	Yellow lights ON	Emergency stop protection	Emergency stop button is pressed	Rotate the emergency stop button Pop-up reset
	Red lights ON	Grounding abnormality	The ground wire is not wired or the neutral wire is reversed	Check whether the grid connection and charger wiring is correct
	Red light once	Over Voltage	Power supply has short circuit or unstable	1.Check the power supply 2.Check the wire of power supply
	Red light twice	Under Voltage	Power supply voltage is insufficient	1.Check the power supply 2.Check the wire of power supply
	Red light thrice	Leakage fault	Leakage happens	1.Reset with emergency stop button 2.Check the charger connector or vehicle for leakage

Fault Status				
LED Indicator	LED Status	Status Description	Potential Cause	Solution
 ...	Red light flashes continuously (Once per second)	Over current	Short circuit may happen	Call for professional repair
 ...	Red light flashes (Quartic per second)	Over temperature alarm	High temperature	1.Wait for charger cooling 2.Ensure the wiring of charger terminal is not losing
 ...	Alternating red and yellow continuously Red for 0.5 seconds followed by yellow for 0.5 seconds	Abnormal CP signal	The connection between the charger and the vehicle is loose	1.Check if the connector is with water leakage in 2.Ensure the connector is matched with EV
	Red and yellow lights flash once	Abnormal CC signal	The connection between the charger and the vehicle is loose	Check whether the charger connector is firmly inserted
	Yellow light ON triple	LED board is offline	LED board is fault or losing	Open the charger cover and check whether the light board cable is connected correctly and firmly
	Yellow light ON once, red light ON once	DLB is offline	The DLB connection is loose	Check the connection between DLB box and charger
	Yellow light ON once, red light ON twice	DLB abnormal	The connection between the DLB box and the CT is loose or the CT is not clamped	1.Check the CT of the DLB box is in the correct position 2.Check whether the DLB box CT is firmly clamped 3.Check if the phase sequence of the DLB box CT is correct 4.Check if the connection between the DLB box CT and the DLB box is firm

4.4. Firmware Update via OCPP Server

The server sends a firmware upgrade command to the EV charger in the background, and when the set time comes, the firmware starts to download.

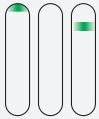

The first and second green lights flash alternately

or other operating status



Download firmware



Green light circularly flows from top to bottom

or other operating status



If the EV charger is charging, install the firmware after the charging is completed.



Extend from the middle to the ends



Install firmware



The yellow light lights up three times



End charging



All green lights on



The update is complete, ready to reconnect to the network

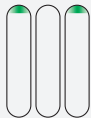

Green light No. 1 flashes slowly (on for 1 second, off for 1 second).



Network connection is successful.



Green Light No. 1 breathing

or other operating status

5. Warranty

In order to ensure the normal service life of charging piles and reduce the risks in use, maintenance must be done within the specified time by professionals with accredited safety maintenance tools.

- 3 years free warranty is provided for any damage or malfunction caused by quality problems from the date of production of the charger.
- Damage caused by operation failure, natural force majeure, incorrect installation or instructions for use is not covered.
- Repair can only be performed by certified and qualified engineer. If any problem occurs during installation or use, contact your dealer first.

6. Manufacturer self-declaration

1. In order to improve the stability of the charger, manufacturer will provide software updates for at least three years from the date of manufacture of the charger.
2. The charger will not collect and save users' sensitive personal data, such as payment information, timestamped location data, audio input stream or biometric data.
3. The manufacturer will not collect telemetry data of the charger through remote service.

7 : OCPP EV Charger Network Configuration Guideline

7.1 : Enter Wi-Fi AP Configuration Mode

The network configuration of the EV charger needs to be done when the connector is disconnected from the EV. If the connector is already plugged into the car's charging socket, please unplug it first.

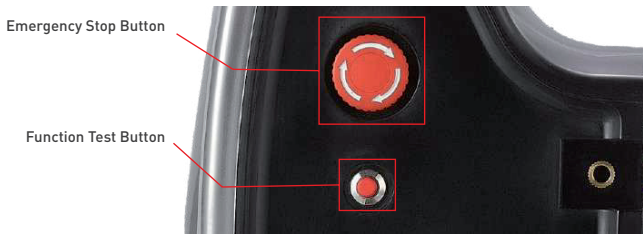

- The method for the charger to enter AP configuration mode:
- Disconnect the charger.
- Press the emergency stop button.
- Power on the charger.

When the EV charger beeps, and the yellow light flashes. That indicates that the EV charger has entered the configuration mode. Please be careful: not to rotate out the emergency stop button. Rotating out is to exit the configuration mode. Please rotate out the emergency button when the configuration is completed.

NoteFor the EV chargers with firmware version lower than v1.0.26, long press the function test button while pressing down the emergency stop button.

7.2 : Enter the configuration interface

1. Open the Wi-Fi list of mobile phone, tablet or computer and find the Wi-Fi named "EVSE-XXXXXXX" (this Wi-Fi signal is sent by EV charger at AP configuration mode, and the number in the WIFI name means the factory number of EV charger)
2. Connect to this Wi-Fi through your computer or mobile phone (The Wi-Fi name is "EVSEXXXXXXXXXX", and the default password is "12345678").
[You can reset the password to default: Power ON the charger; Find the reset button on the PCB inside of the EV charger; Press it and hold for 5s.]

NoteFor better configuration, please turn off the phone's internet function because the mobile data traffic might effect enter the configuration page.

3. Using a browser, enter and access "192.168.1.1"



4. At this time, a login page appears, and the default password of the login page is the same as that of Wi-Fi.

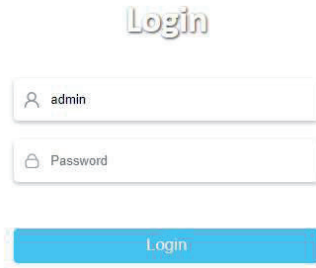

5. After correctly entering the password, click "Login". The EV charger enters the configuration directory page.

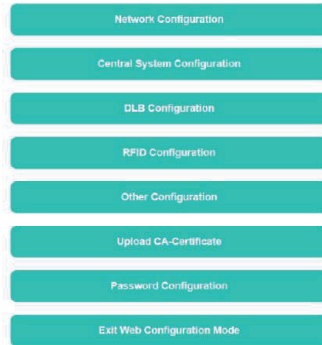

6. On the configuration directory page, user can jump to different sub-pages to configure different parameters

Details of each configuration item in the configuration interface are shown in Table 2.1:

Table 2.1 Details of each configuration item in the configuration interface

Configuration Item	Details of Configuration Item
Open The Network Configuration Interface	NetWork setting, Wi-Fi Config, LTE Config
Open The Central System Configuration Interface	Security, Server, HTTP Basic Authentication, Custom Vendor Info
Open The DLB Configuration Interface	General, Normal DLB, Solar DLB, DLB on cloud
Open The RFID Configuration Interface	General, RFID Unique Config, Reader mode Config
Open The Other Configuration Interface	Parameter configuration, Ground Fault Detection, External Meter Enable, Dry Contact Enable, Authorization Cache, Emergency Stop Button, BLE Reset Button
CA certificate upload	It is suggested to upload the CA certificate of OCPP server to EV charger, which can better ensure the network safety.
Open The Password Configuration Interface	Change Password
Exit Web Configuration mode	Exit Web Configuration mode

7.3 : Network configuration

- Click on the Network Configuration button to enter the network settings interface, where you can see a number of NetWork setting options.

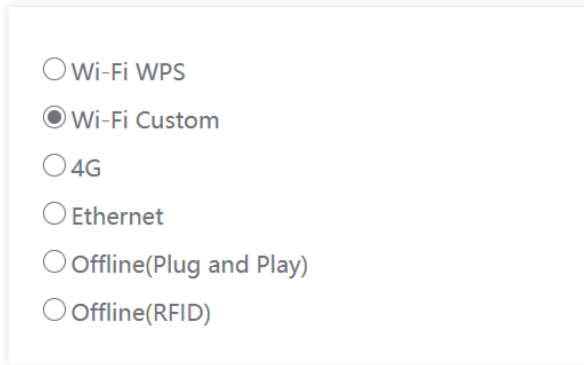

Details of the network settings items are shown in Table 3.1:

Table 3.1 Network setup item details

Configuration Item	Explanation of Configuration Items	Related configuration items
Wi-Fi WPS	Wi-Fi WPS means that the terminal can connect to Wi-Fi via wps. WPS, a wireless encryption authentication method, is used to simplify the security setup and network management of Wi-Fi wireless. Instead of entering the wireless network password, the terminal can connect wirelessly to the router by pressing the WPS button directly.	
Wi-Fi Custom	Connect to Wi-Fi by entering the wireless network name and password.	Wi-Fi SSID Wi-Fi Password
4G	4G is optional. Please note if the EV charger supports 4G networking. If 4G connectivity is needed, please insert the SIM card into the EV charger, and ensure that the SIM card is not encrypted by PIN code.	LTE APN LTE APN User LTE APN Password
Ethernet	Connect the network cable into the Ethernet RJ45 port of the EV charger for networking.	
Offline(Plug and paly)	With this option enabled, the OCPP EV charger will be disconnected from the OCPP platform. It can be used as an unsmart EV charger with the plug-and-charge mode.	
Offline(RFID)	With this option enabled, the OCPP EV charger will be disconnected from the OCPP platform. It can be used as an unsmart EV charger with the RFID card swiped charging mode.	RFID Unique RFID Unique ID

If you want the charger terminal to connect to Wi-Fi by entering the wireless network name and wireless network password, you will need to select the Wi-Fi Custom mode network settings and configure the network according to the following steps:

- Click to select "Wi-Fi Custom".

Wi-Fi WPS
 Wi-Fi Custom
 4G
 Ethernet
 Offline(Plug and Play)
 Offline(RFID)

- Scroll down the interface to find WIFI Config and enter the corresponding Wi-Fi name (Wi-Fi SSID) and Wi-Fi password.

Wi-Fi SSID

Wi-Fi Password

The descriptions of the Wi-Fi configuration items are shown in Table 3.2:

Table 3.2 Wi-Fi configuration item descriptions

Configuration Item	Explanation of Configuration Items	Maximum Length
Wi-Fi SSID	This configuration requires entering the name of the Wi-Fi. The Wi-Fi will be connected to the EV charger when "Wi-Fi Custom" is selected in the networking mode.	30
Wi-Fi password	This configuration requires entering the Wi-Fi password when Wi-Fi Custom is selected in the networking mode.	30

If you wish to configure the charger for network via a 4G connection, you will need to confirm that your charger supports 4G networks, that the SIM card is inserted into the charger and that the SIM card is not PIN encrypted, and then configure the network according to the following steps:

- Click to select "4G".

Wi-Fi WPS
 Wi-Fi Custom
 4G
 Ethernet
 Offline(Plug and Play)
 Offline(RFID)

- Scroll down the interface and find LTE Config and fill in the LTE configuration fields.

LTE APN

LTE APN User

LTE APN Password

The descriptions of the LTE configuration items are shown in Table 3.3:

Table 3.3 Description of LTE configuration items

Configuration Item	Explanation of Configuration Items	Maximum Length
LTE APN	You need to enter the name of the 4G network access point of the SIM card when selecting 4G connectivity mode.	
LTE APN User	APN username, not required if it is unavailable.	30
LTE APN Password	APN user password, not required if it is unavailable.	30

If you want the charger terminals to be networked via Ethernet, you will need to connect a network cable to the Ethernet RJ45 port of the EV charger and then configure the network according to the following steps:

- Click to select "Ethernet".

Wi-Fi WPS

Wi-Fi Custom

4G

Ethernet

Offline(Plug and Play)

Offline(RFID)

By default, the IP Config of an EV charger is a Dynamic IP (DHCP) configuration, i.e. the server automatically assigns an IP address to the internal network or to the ISP. If you need to set a fixed IP address to access the Internet, you need to select Static IP Config and fill in the appropriate Static IP, Gateway and Netmask, otherwise you can leave it as default.

Static IP
 DHCP

Static IP
 0.0.0.0 _____

Gateway
 0.0.0.0 _____

Netmask
 0.0.0.0 _____

- Click the SAVE button to exit the Network Configuration interface and return to the Configuration Page.

7.4 : RFID Configuration

Note: If you have selected the Plug and play mode when doing the network setup, RFID configuration is not required. Please ignore this step, otherwise please do the RFID configuration.

- Click on the "RFID Configuration" button to configure the RFID.
- Make the General setting. In this setting, you can set the RFID card to be used only when the charger is offline or at any time.

RFID is only used offline
 RFID can be used at any time

The descriptions of the RFID General Settings items are shown in Table 6.1:

Table 6.1 Description of the general setting items for RFID configuration

Configuration Item	Explanation of Configuration Items
RFID is only used offline	When you enable this configuration, the online EV charger will disable the use of RFID to start charging. Only the function of local authentication is available when the network is abnormal and the EV charger is offline.
RFID can be used at any time	When this configuration is enabled, you can swipe the RFID card to charge at any time.

- Do the RFID Unique Config. In this configuration, you can choose whether or not to enable the RFID Unique configuration. If so, you will need to fill in the corresponding RFID Unique ID.

Example: If your IC card number is "9E46BA0D", you need to configure Unique ID as "9E46BA0D".

RFID Unique Enable
 RFID Unique Unable

RFID UniqueID
 9E46BA0D _____

The configuration items for RFID unique configuration are described in Table 6.2:

Table 6.2 Description of each configuration item for RFID unique configuration

Configuration Item	Explanation of Configuration Items	Maximum Length
RFID Unique Enable/ RFID Unique Unable	Select offline swiping card mode in the network configuration page. After this mode has been activated, you can start charging in the permanently offline mode with the set card.	
RFID Unique ID:	Card Number Configuration	20

- Make Reader mode configuration. This configuration allows you to set the reader mode of the charger, including RFID UID mode, RFID Custom mode and RFID Manufacturer mode. If you select RFID Custom mode, you will need to enter the card number storage address and set the RFID Custom Password in the RFID Custom Block.

RFID UID Mode
 RFID Custom Mode
 RFID Manufacturer Mode

RFID Custom Block

0

RFID Custom Password

The configuration items for the reader mode configuration are described in Table 6.3:

Table 6.3 Description of configuration items for reader mode configuration

Configuration Item	Explanation of Configuration Items	Maximum Length
RFID UID Mode	IC card manufacturer offers its own physical card numbers. If the card is the M1 card, EV charger can recognize its physical card number.	
RFID Custom Mode	In custom mode, the EV charger will read the IC card number based on the encryption method configured by the user.	
RFID Manufacturer Mode	In the default reading card mode, the EV charger only recognizes IC cards configured by the writing tool, and IC card offered by will have their card numbers configured by in this way.	
RFID Custom Block:	Card Number Storage Address	0-63
RFID Custom Password:	Card PIN must be 12 characters	0-9, a-f, A-F

- Click the SAVE button to exit the RFID Configuration interface and return to the Configuration Page.

7.5 : Other configuration

- Click on the "Other Configuration" button to enter the other configuration interface.
- Do parameter configuration. In this configuration you can set The maximum current of the one connector, the Meter Value Sample Interval and the ConnectionTime Out setting.

The maximum current of the one connector

25

MeterValueSampleInterval

60

ConnectionTimeOut

120

The configuration items for the parameter configuration are described in Table 7.1:

Table 7.1 Description of configuration items for parameter configuration

Configuration Item	Explanation of Configuration Items
The maximum current of the one connector	This item sets the maximum allowable charging current for a single connector.
Meter Value Sample Interval	Sets the interval for Meter report logs. The minimum setting time is 10 seconds.
ConnectionTime Out	Timeout setting for swiping the card when the connector is unplugged. When it is set to 0, swiping the card is forbidden in the condition that the connector is unplugged.

- Do the ground fault detection.

When the charger encounters a ground failure or poor grounding, which the function of the ground fault detection is to report a ground disconnection warning, which triggers ground protection. Thus, it prevents the charger from charging the vehicle.

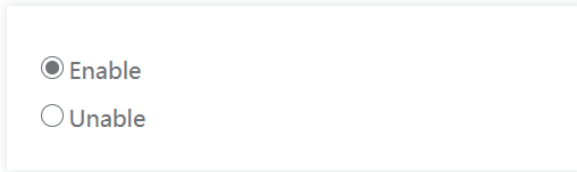

The ground fault detection options are described in Table 7.2:

Table 7.2 Description of ground fault detection options

Configuration Item	Explanation of Configuration Items
Ground Fault Detection Enable / Unable	Ground detection function can be configured according to actual requirements.

- Make the External Meter Enable setting. If this configuration is enabled, the charger will use the data from the external meter as its own metering data. Turn this on if an external meter is already installed.

NoteThe brand and type of external meter used for the charger should be specified by the manufacturer, and it is recommended that the user only change this configuration on the first installation.

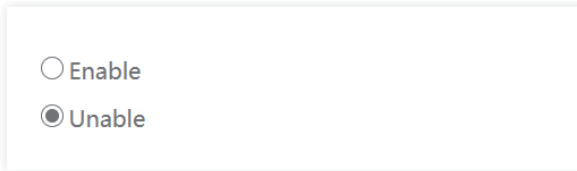

The external meter enablement options are described in Table 7.3:

Table 7.3 Description of external meter enablement options

Configuration Item	Explanation of Configuration Items
Use External Meter Enable/Unable	When this configuration item is enabled, the EV charger uses the data from the external meter as its own metering data. It should be noted that, the brand and type of used meter should be specified by the manufacturer. It is recommended that the user only changes this configuration item on the first installation. In addition, due to the same hardware interface the DLB and the external meter use, either external meter or DLB function can be enabled at the same time.

- Make the Dry Contact Enable setting. If this configuration is enabled, the charger will determine if the charger is in a period where charging is allowed based on the status of the dry contacts.

Enable
 Unable

The dry contact enablement options are described in Table 7.4:
 Table 7.4 Description of dry contact enable options

Configuration Item	Explanation of Configuration Items
Dry Contact Enable/ Dry Contact Unable	Dry Contact is an optocoupler isolated input interface. When this function is enabled, the EV charger will determine whether or not it is in the allowable charging period based on the status of this interface.

- Make Authorization Cache setting. If this configuration is enabled, the card will have a cache record and the charger will still be able to be charged for a certain period of time when the server is unexpectedly offline.

Enable
 Unable

The cache authorization options are described in Table 7.5:
 Table 7.5 Description of cache licensing options

Configuration Item	Explanation of Configuration Items
Authorization Cache Enable/ Authorization Cache Unable	If this configuration is enabled, the card will have a cache record. Therefore, when the server is unexpectedly offline, the card can be swiped to start charging. (there is a term of validity). When the server is restored, the data will be automatically uploaded for deducting the charging consumption, etc.

- Set the emergency stop button.
 The user can choose to enable or not enable the emergency stop button. When the user chooses to not enable it, the emergency stop of EV charger by emergency stop button will be disabled.

Enable
 Unable

- Set the BLE reset button.
 The user can choose to enable or not enable the BLE reset button. When the user chooses to not enable it, the BLE reset by the emergency stop button and the function test button will be disabled.

Enable
 Unable

- Click the SAVE button to exit the Other Configuration interface and return to the Configuration Page.

7.6 : Upload CA-Certificate

It is suggested to upload the CA certificate of OCPP server to EV charger, which can better ensure the network safety.

7.7 : Password Configuration

- Click on the "Password Configuration" button to enter the password configuration interface.
- You can change the Wi-Fi password of charger on the password configuration interface. If you need to change the Wi-Fi password of charger, you shall enter the Wi-Fi password you are currently using in Old Password, then enter the new password in New Password, and repeat the new password in New Password Again for confirmation.

Old Password

New Password

New Password Again

The settings for Change Password are described in Table 9.1:

Table 9.1 Description of setting items for password change

Configuration Item	Explanation of Configuration Items
Old Password	When you want to change your password, you need to enter your old password.
New Password	Enter the old password, and then enter the new password to change it.
New Password Again	Repeat the new password in New Password Again

Note: When WIFI AP password is changed, WEB login password automatically changes, and vice versa.

When you forget your password, you can restore it to its default value through the following ways: You can press and hold the reset button inside the EV charger for 5 seconds after pressing the emergency stop button.



- Click the SAVE button to exit the Password Configuration interface, and return to the Configuration Page.

7.8 : WPS Connection Method

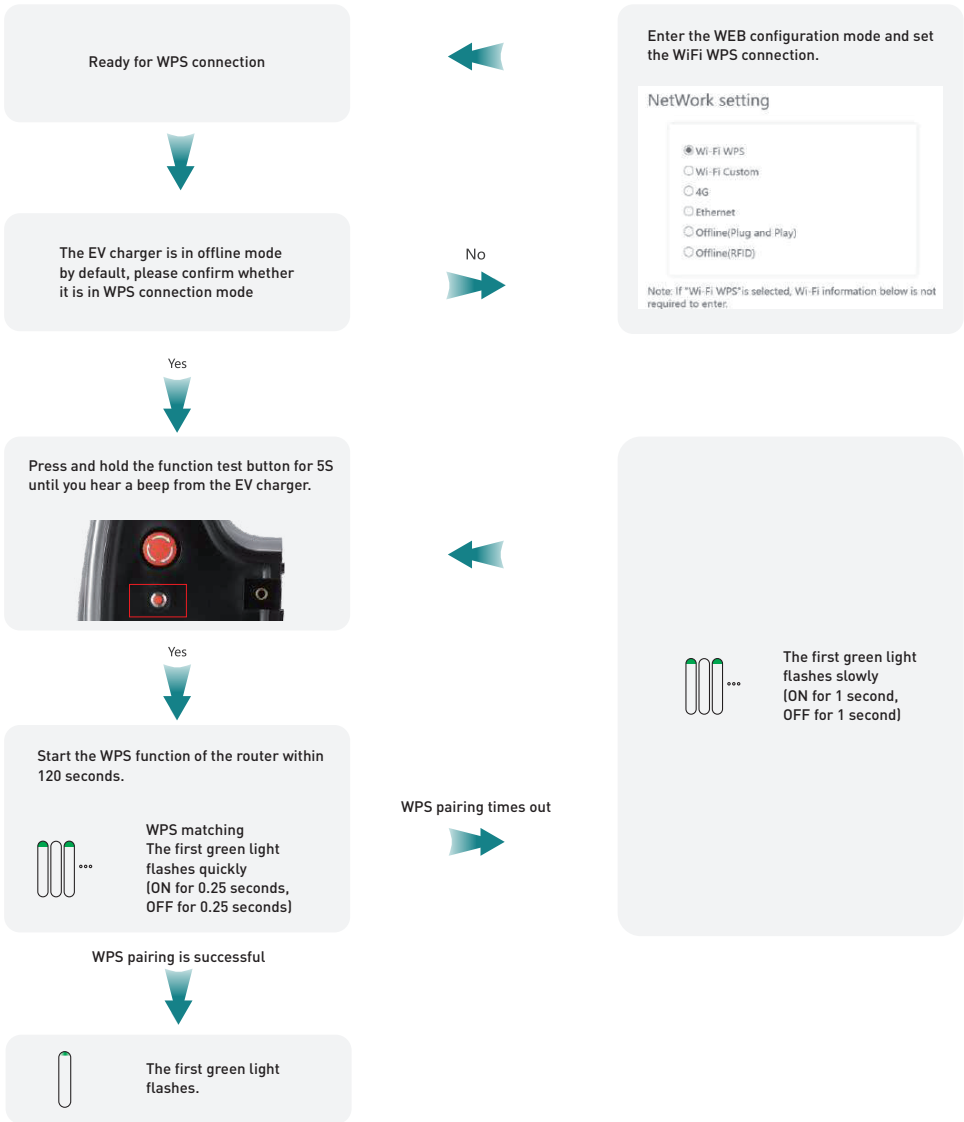

7.9 : Exit Web configuration mode

- When the settings are complete, click on the "Exit Web Configuration Mode" button. The EV charger will automatically connect to the server according to the parameters set.
- After the server is successfully connected, the first green light will flash. In case of a failure to connect to the server for a long time, check whether the network and server configurations are entered correctly.

7.10 : Monta App Set-up & Configuration

Before you can proceed with the flow, make sure that you have configured the charge point correctly, so it can establish a connection with Monta.

1. Point the camera of your phone at the Monta QR sticker and scan it.



5m Tethered EV Charger
Model No. 20284



Socket EV Charger
Model No.20285

When you scan the QR code on the charge point, you will be prompted to open Monta Charge. If you do not have the app yet, you will see how to download it.

Click on the "Open" button.

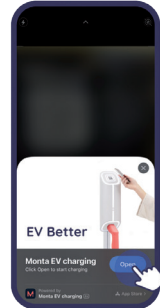

2. Add the serial number of the charge point

After you have scanned the Monta QR code, the app has recognized the Brand and Model of your charge point. Now, you need to add the serial number.

Scan Serial QR

On some charge points, there is a QR code, which contains the serial number. Click the button "Scan Serial QR" and point your phone at the code to scan it.

Add serial number manually

If your charge point does not have a QR code on it, or your phone does not support such scanning, you can also manually add the serial number.

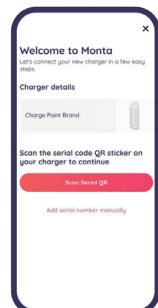

3. Fill in the charge point details

Enter the name and location of your charge point and select which Team you want to register it in.

Then, click on "Connect to Monta" to continue.

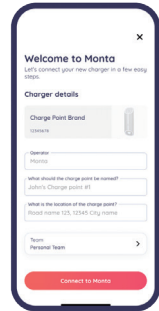

The screenshot shows the 'Welcome to Monta' screen with the following fields and options:

- Charge Point Brand: (dropdown menu)
- Operator: (text input field)
- Who should the charge point be named?: (text input field)
- What is the location of the charge point?: (text input field)
- Team: (dropdown menu with 'Personal Team' selected)
- Bottom button: 'CONNECT TO MONTA' (red)

4. Wait to connect

Here, the system is checking if your charge point is online and is trying to connect to it.



5. Congrats, you have connected your charge point to Monta!

6. What's next?

There are so many things you can do now that your charge point is connected to Monta!

Here are some suggestions:

- Perform your first charge with Monta.
- Set up Charging rules
- Enable SmartCharge
- Make your charge point Public, so others can charge on it.
- Invite your friends and neighbours to use your charge point.

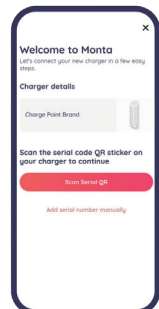

The screenshot shows the 'Welcome to Monta' screen with the following elements:

- Charge Point Brand: (dropdown menu)
- Instruction: 'Scan the serial code QR sticker on your charger to continue' (with a QR code icon)
- Buttons: 'Scan Serial QR' (red) and 'Add serial number manually' (grey)

VORSPRUNG[®]

Vorsprung is a subsidiary of
DropNet Ltd London N22 8HX