

# SUPERLOCK 2.0 QUICK-EXIT KEYPAD ENTRY

## Specification Sheet BQDG 2.0

### FEATURES

- Quick-Exit: Push pad designed to facilitate rapid exit through gates, with a 14 digit keypad for secure entry.
- Easy to fit: Slim 70mm (2 3/4") wide lock case, along with an adjustable and removable latchbolt, ensures easy fitting to gates.
- Secure: The latchbolt moves 15mm (5/8"), ensuring the bolt enters deep into the gatepost.
- Durable: The latchbolt is supported on the edge of the gatepost to reduce friction and wear.
- Anti-corrosion: Designed for outdoor use for long-lasting performance.
- Auto-latching: Includes a gate post strike plate for easy and secure latching.
- A security shroud is available to prevent access to the push pad from the outside



Product code	Description
BQDG1030L	To fit 10-30mm (1/2" - 1 1/4") gate frames, left hand
BQDG1030R	To fit 10-30mm (1/2" - 1 1/4") gate frames, right hand
BQDG4060L	To fit 40-60mm (1 1/2" - 2 1/4") gate frames, left hand
BQDG4060R	To fit 40-60mm (1 1/2" - 2 1/4") gate frames, right hand

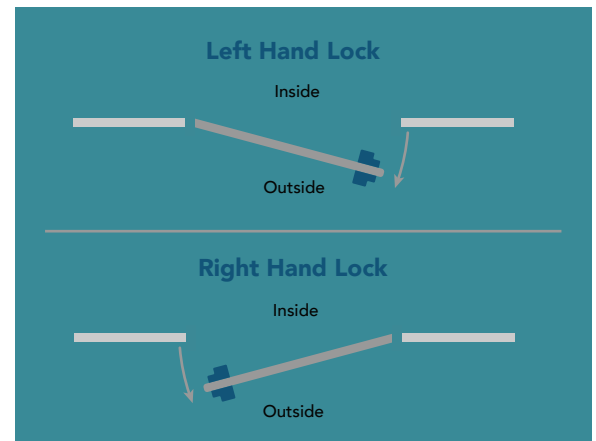

### INSTALLATION

1. Drill 2 x 9mm (3/8") holes at 140mm (5 1/2") centres for fixing bolts provided.
2. Drill a 18mm (3/4") clearance hole for the latchbolt at 60mm (2 3/8") centres up from the bottom fixing hole.
3. Hold the lock against the back of the box section and screw on the latchbolt through the larger hole.
4. Lock the latchbolt with the hex key supplied by inserting the hex key into the end of the latchbolt.
5. Fix lock in place using the stainless steel bolt support plate and the countersunk screws provided. Ensure the latchbolt moves freely.
6. Fix strike plate by either welding or screw fixing onto the gate post.
7. Maintenance: Every 6 months, lubricate the latchbolt with light oil. Annually, dismantle the lock and spray mechanism with light oil.

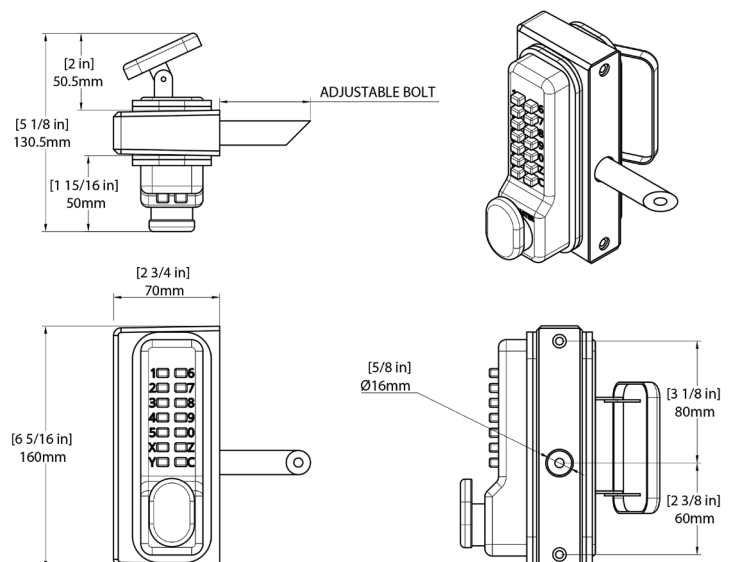

# SUPERLOCK 2.0 QUICK-EXIT KEYPAD ENTRY

Specification Sheet  
**BODG 2.0**

**LOCK CODE: C**

## TO CHANGE THE CODE

1. Check the original code is working on the keypad.
2. Remove the keypad off the lock. To do this, unscrew the two screws on the back of the lock using a hex key.
3. Turn the keypad over and remove the 4 screws.
4. Lift off the covering panel carefully as there are 10 springs attached to this panel. Note that the red tumblers relate to the code shown above. Also note that the C tumbler is uncoloured and should not be removed.
5. To change the code hold the keypad with the code buttons down and depress & hold the C button (if this is not done you may damage some of the internal components). Reposition the tumblers to the new code (red tumblers are coded and blue tumblers are uncoded). Ensure that the square cut-out on each tumbler is facing the outside of the lock body, also ensure that the coloured mark is facing upwards. If any one tumbler is upside down or the wrong way round the lock will not work and if forced will break the internal components. The code must always start with a 'C'.

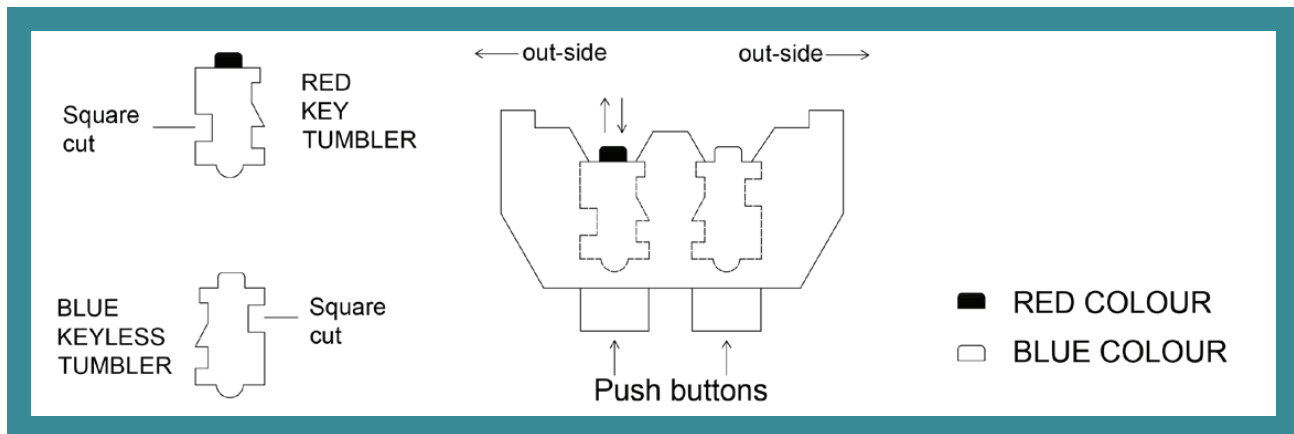

6. Replace the covering panel and tighten the screws. Screw the keypad and rear handle panel back onto the lock.
7. The code is now changed, check to see that it is working correctly and make a note of the code for future reference. Once satisfied that the lock is working correctly refit keypads to the panel using the 2 screws and reassemble the lock.

## MAINTENANCE

### 6 Monthly:

1. Remove keypad and rear handle panel from the lock.
2. Spray the inside of the lock thoroughly with WD40 or equivalent, through the tumbler holes at the back of the lock.
3. Spray all the fixing accessories and the latch with WD40 or equivalent.
4. Push each of the buttons and rotate the knob several times to make sure the lock is working smoothly.