



Home Garden

DIRECT



www.homegardendirect.co.uk :

IR047
SHOE CABINET

WLTS-SH-CB-01

Instruction manual

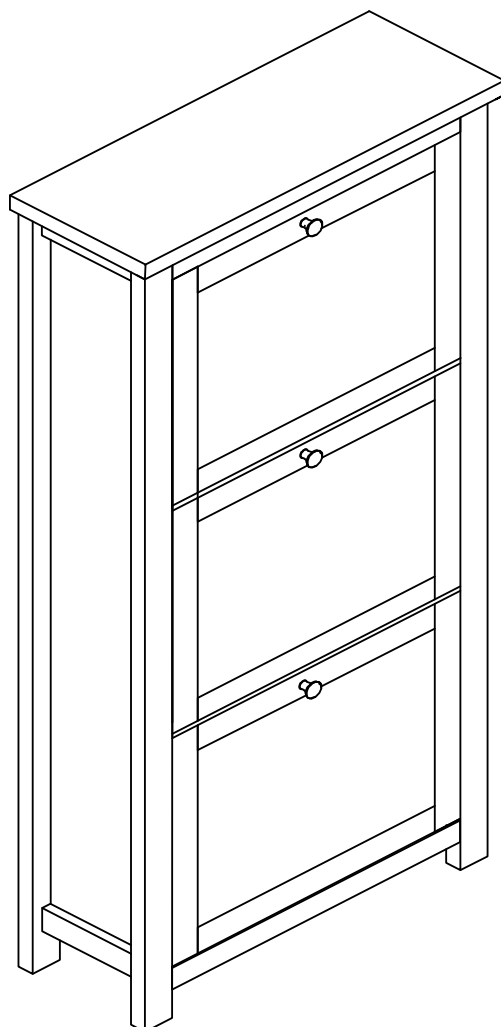

www.homegardendirect.co.uk



SAFETY AND CARE ADVICE

PLEASE READ THESE INSTRUCTIONS CAREFULLY AND KEEP FOR FUTURE

- *Check you have all the components and tools listed on pages 2 or 3.*
- *Remove all fittings from the plastic bags and separate them into their groups.*
- *Keep children and animals away from the work area, small parts could choke if swallowed.*
- *Make sure you have enough space to layout the parts before starting.*
- *Do not stand or put weight on the product, this could cause damage.*
- *Assemble on a soft level surface to avoid damaging the unit or your floor (use opened out unit carton).*
- *We do not recommend the use of power drill/drivers for inserting screws, as this could damage the unit. Only use hand screwdrivers.*

COMPONENTS — PANELS

Please check you have all the panels listed below:

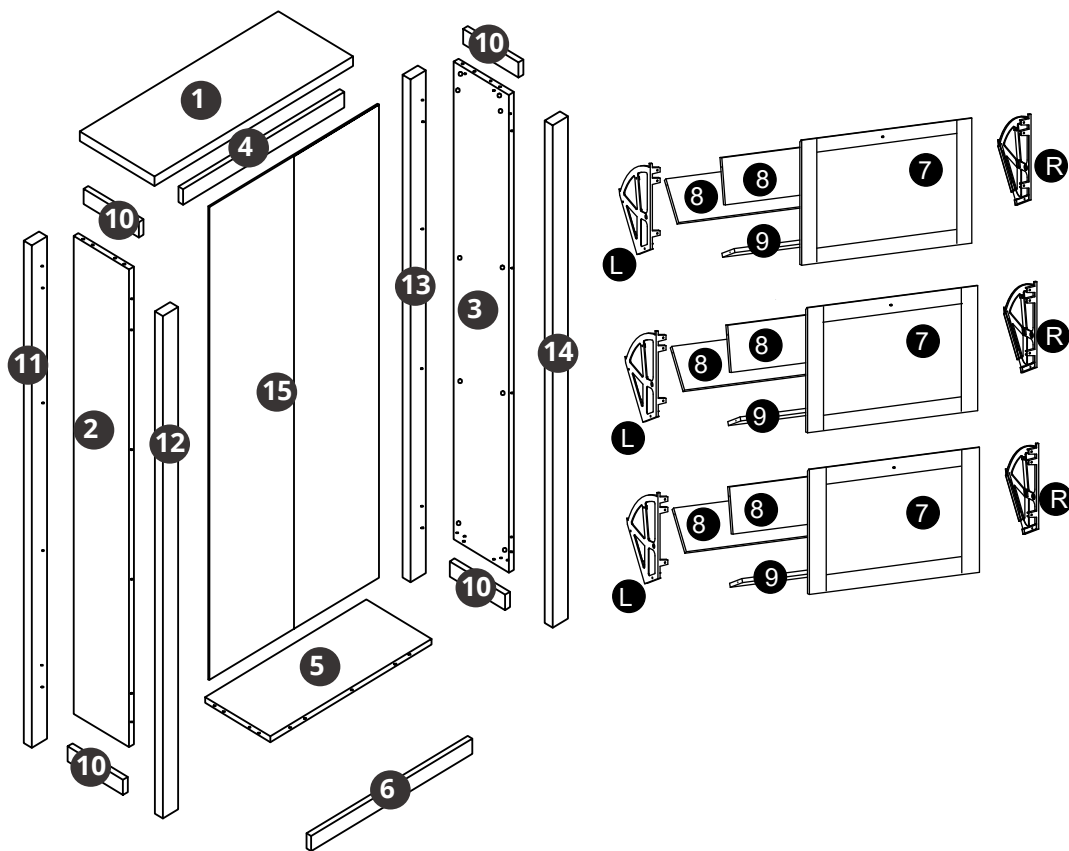









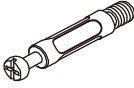
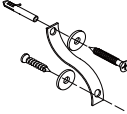

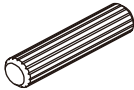

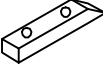

PANEL LIST

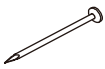
1	Top Panel	x1	14	Right Front Frame	x1
2	Left Side Panel	x1	15	Back Panel	x1
3	Right Side Panel	x1			
4	Top Cross Bar	x1			
5	Bottom Cross Bar	x1			
6	Bottom Panel	x1			
7	Door Front Panel	x3			
8	Shelt Panel	x6			
9	Base Panel	x3			
10	Side Cross Bar	x4			
11	Left Back Frame	x1			
12	Left Front Frame	x1			
13	Right Back Frame	x1			

COMPONENTS — FITTINGS

Please check you have all the fittings listed below:

- | | |
|---|--|
| <p>A</p>  <p>Peg M6*35mm x26</p> | <p>I</p>  <p>Safety Device x2</p> |
| <p>B</p>  <p>Lock M15*12mm x26</p> | <p>J</p>  <p>Screw M4*20mm x3</p> |
| <p>C</p>  <p>Dowel M8*30mm x20</p> | <p>K</p>  <p>x6</p> |
| <p>D</p>  <p>Handles x3</p> | <p>L</p>  <p>x6</p> |
| <p>E</p>  <p>Screw M4*40mm x3</p> | <p>M</p>  <p>x6</p> |
| <p>F</p>  <p>Screw M4*25mm x8</p> | <p>N</p>  <p>Shoe plate x3</p> |
| <p>G</p>  <p>Pin x46</p> | <p>O</p>  <p>Screw M3.5*14mm x48</p> |
| <p>H</p>  <p>Plastic Feet x4</p> | <p>P</p>  <p>Screw M4*14mm x6</p> |

<p>TOOLS NEEDED (We don't provide)</p>		Phillips Screwdriver x 1
		Hammer x 1

ASSEMBLY INSTRUCTIONS

Step 1

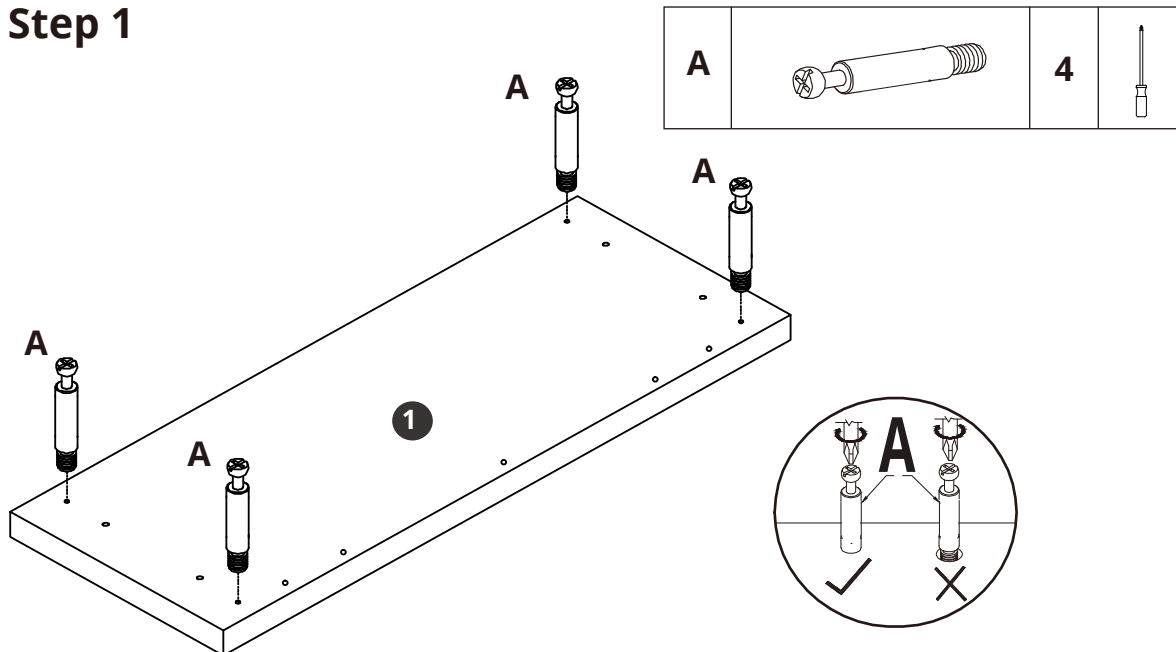

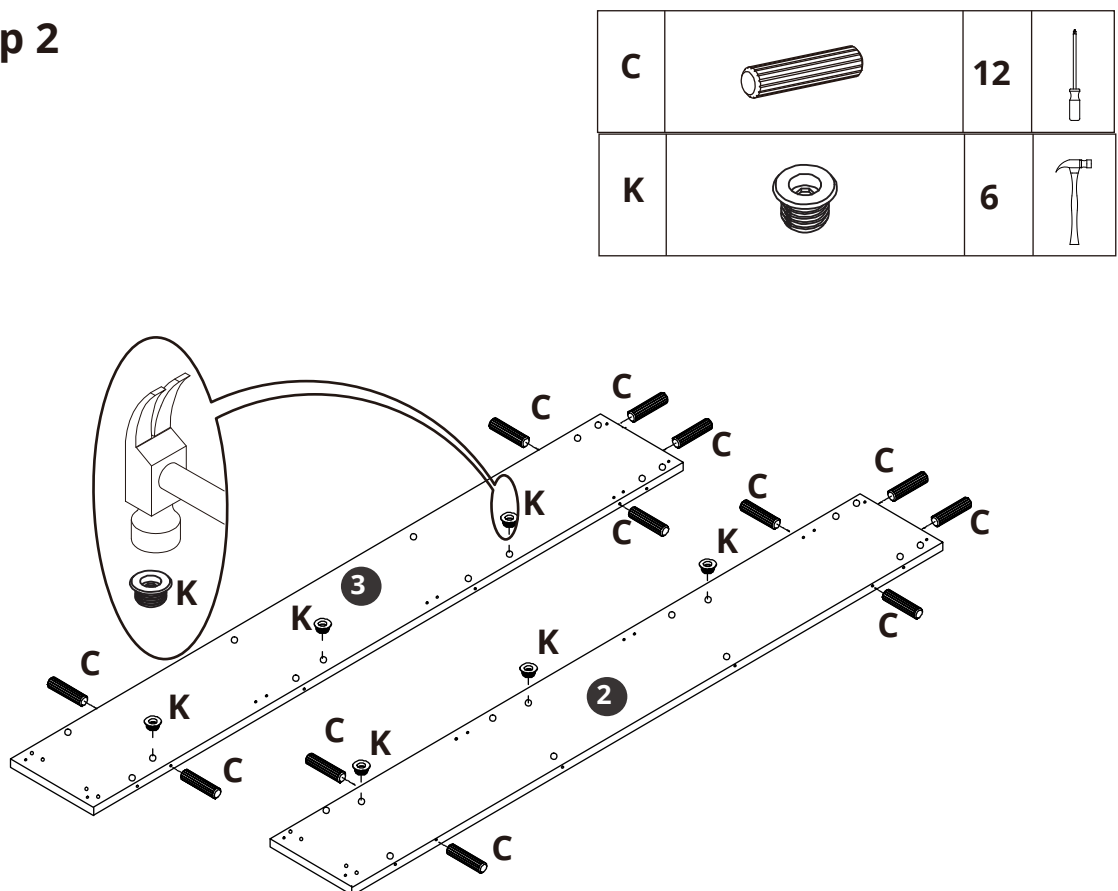

Step 2





ASSEMBLY INSTRUCTIONS

Step 3

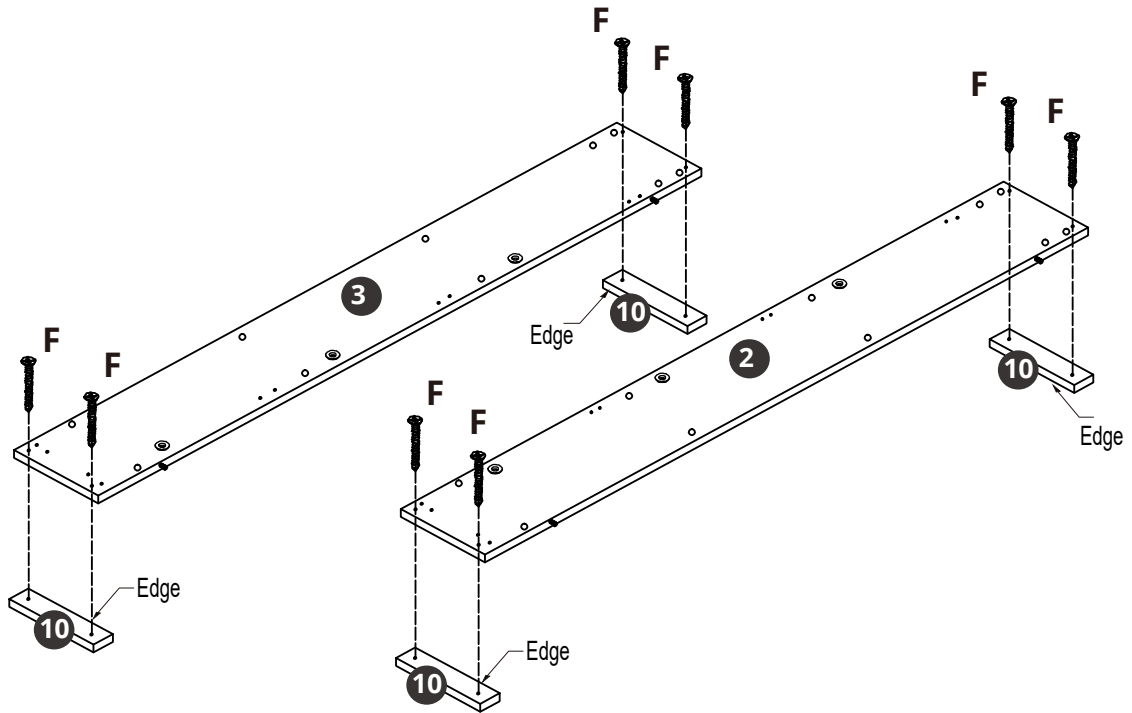
F		8	
---	---	---	---





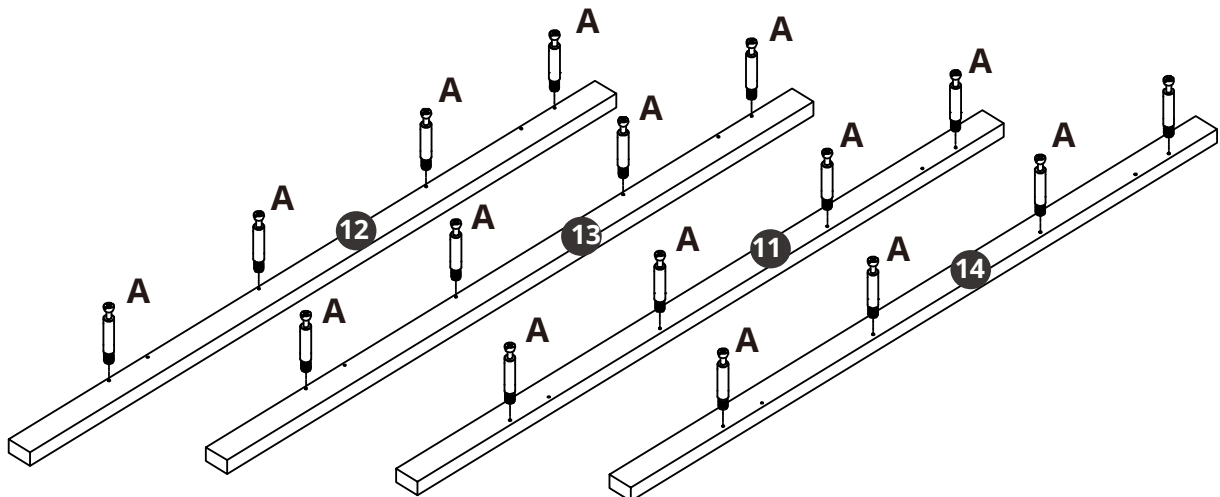

Step 4

A		16	
---	--	----	---





ASSEMBLY INSTRUCTIONS

Step 5

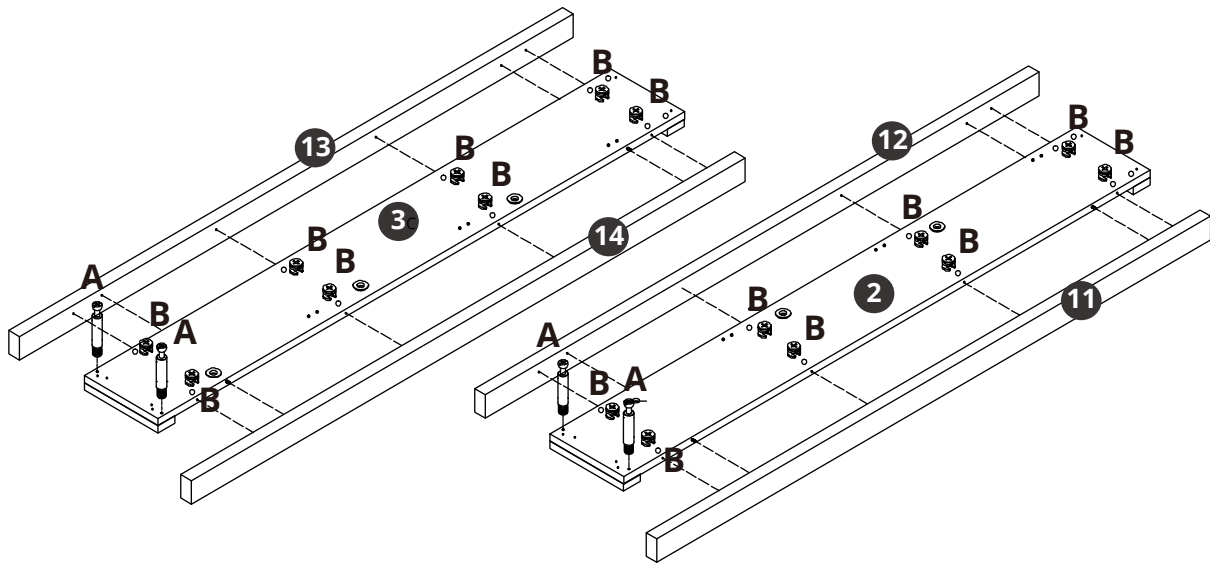
A		4	
B		16	

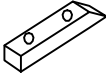

Step 6

L		6	
O		12	

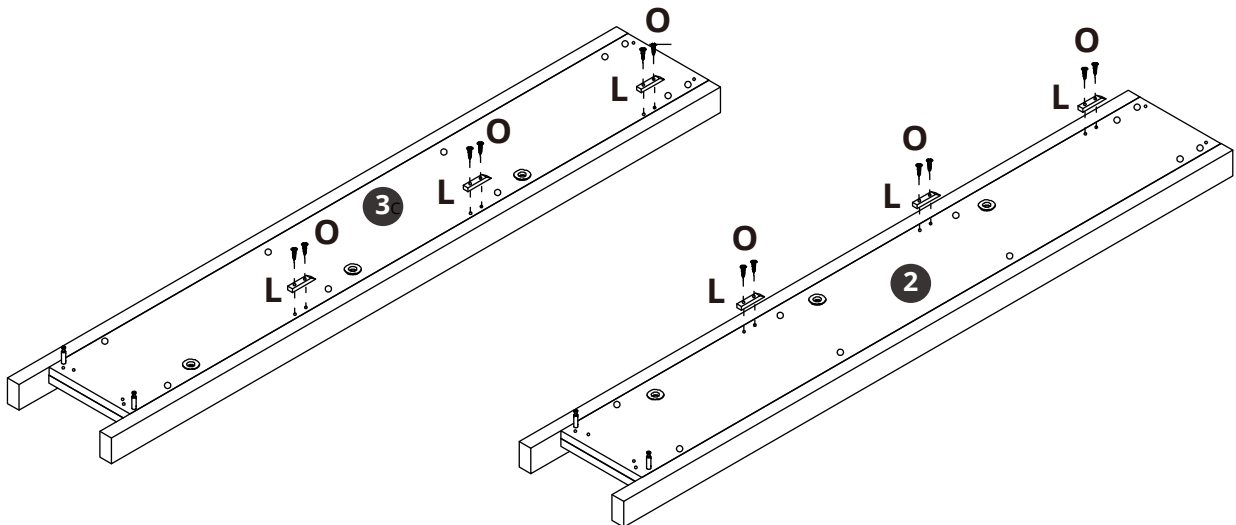

ASSEMBLY INSTRUCTIONS

Step 7

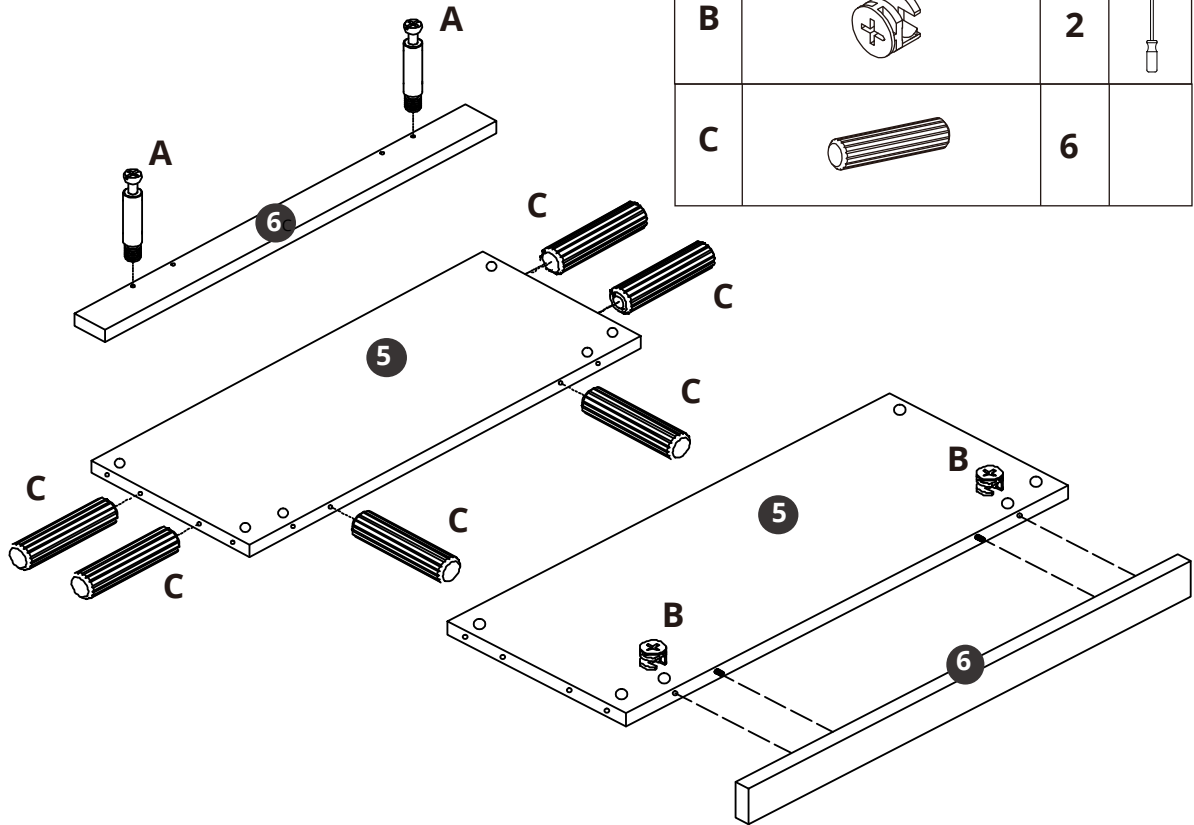

Step 8

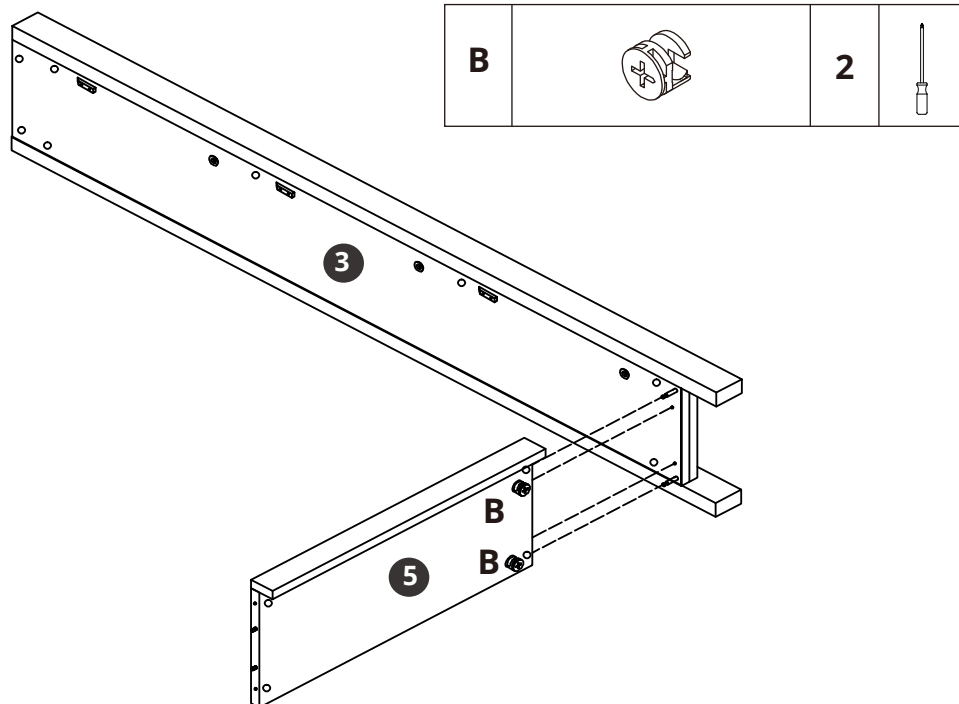

ASSEMBLY INSTRUCTIONS

Step 9

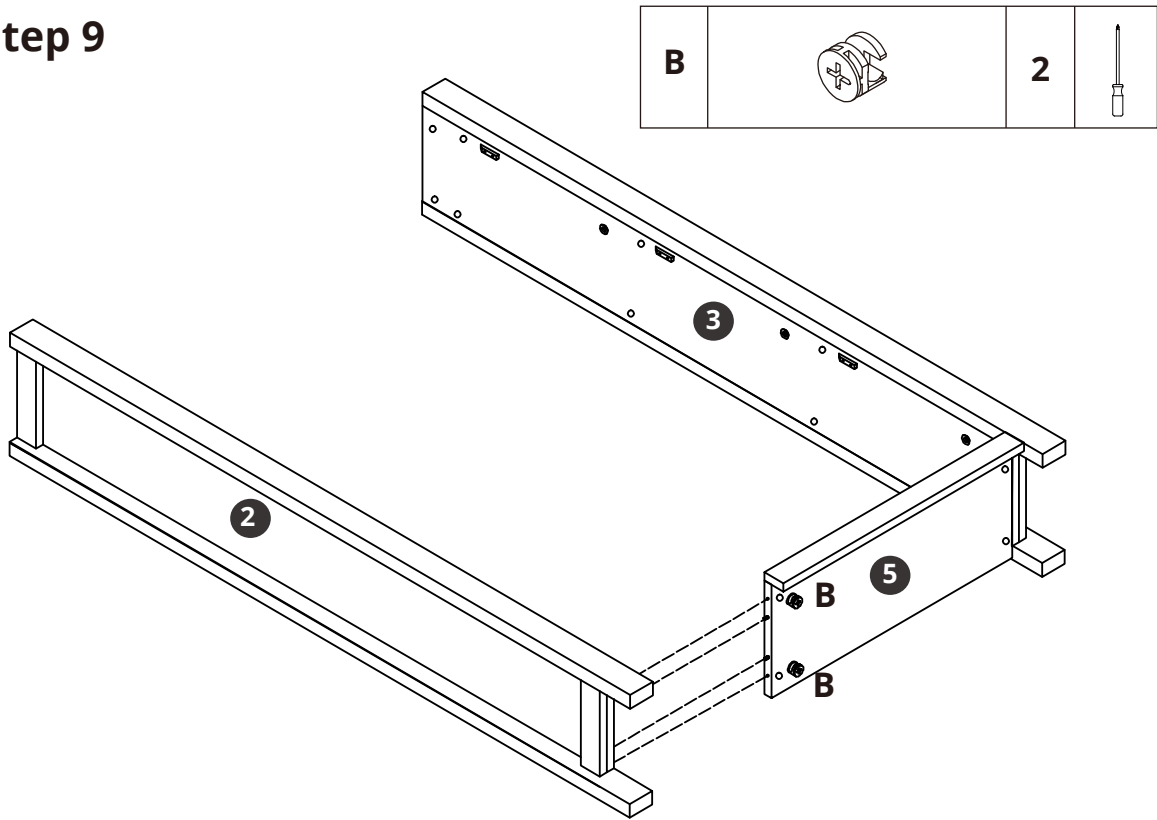

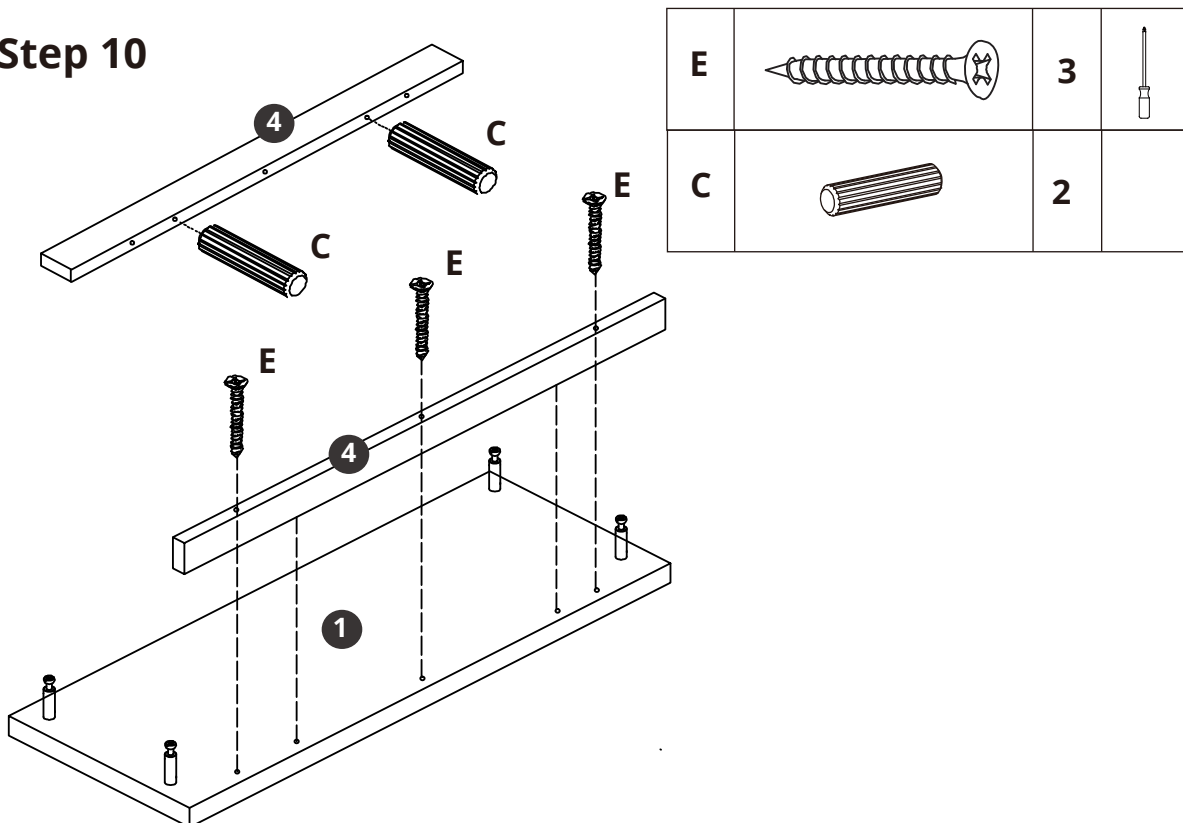

Step 10



ASSEMBLY INSTRUCTIONS

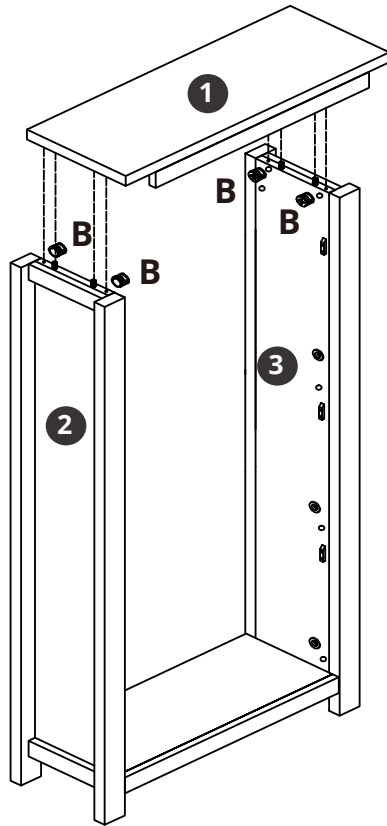



Step 11

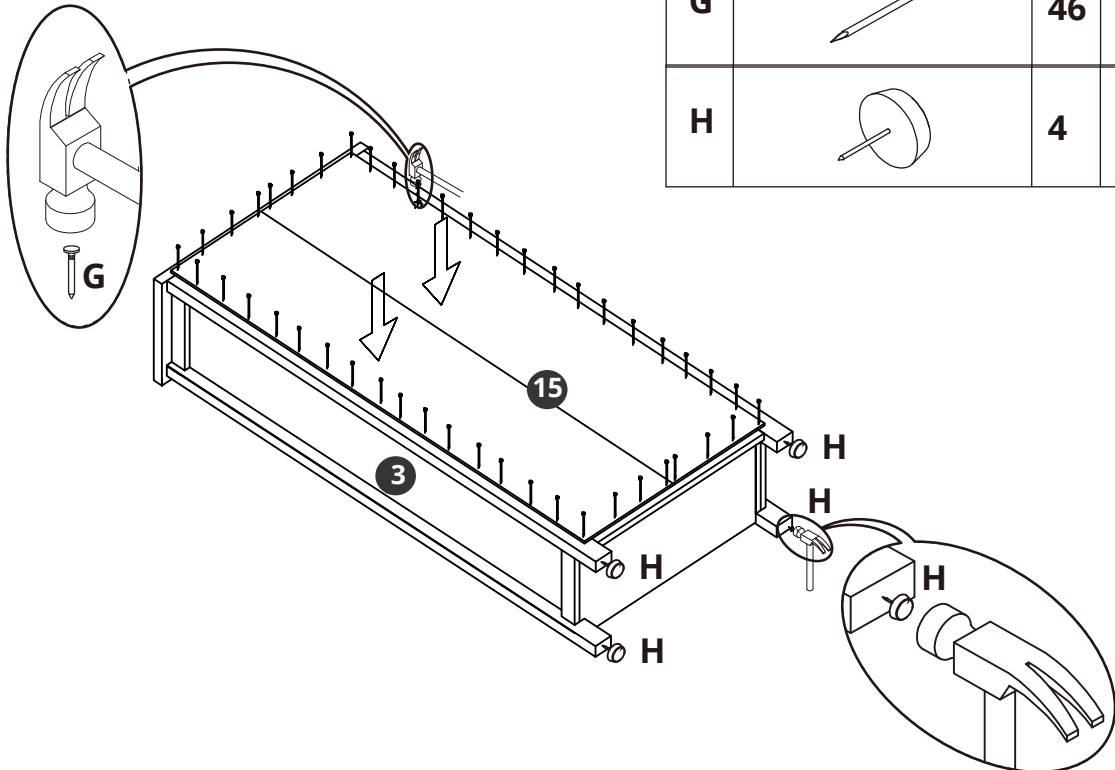

B		4	
---	---	---	---

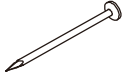

Step 12



G		46	
H		4	



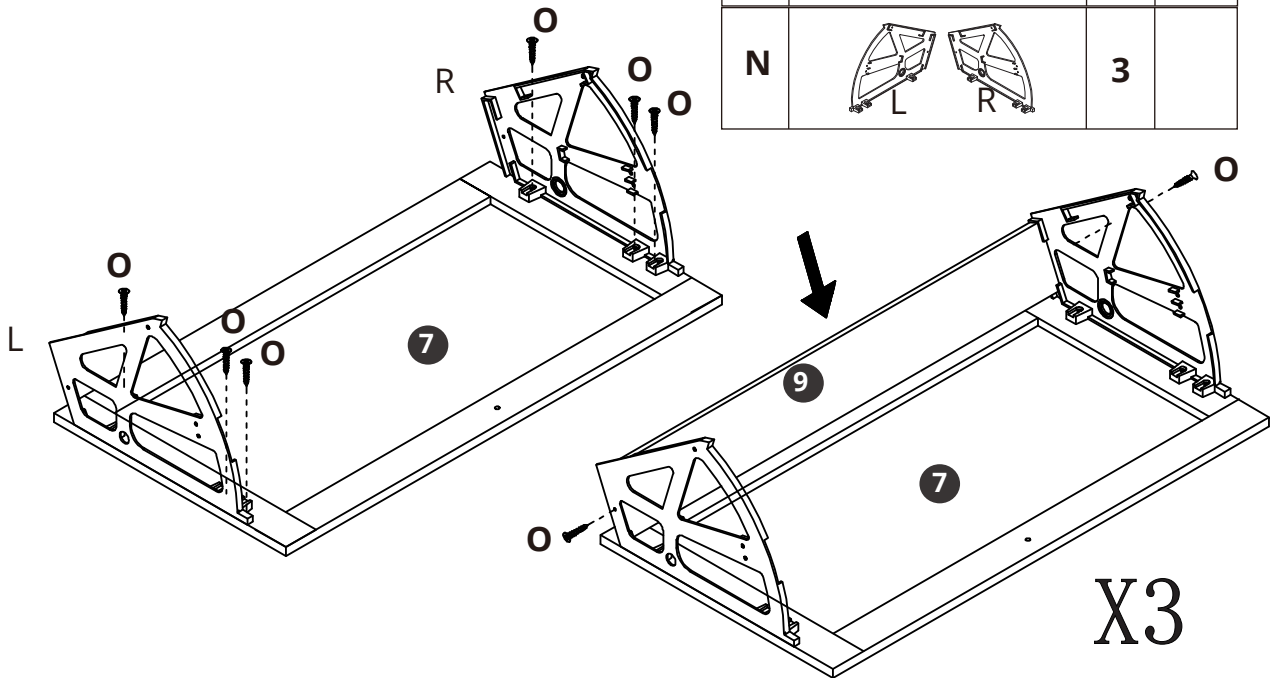

ASSEMBLY INSTRUCTIONS

Step 13

O		24	
N		3	



Step 14



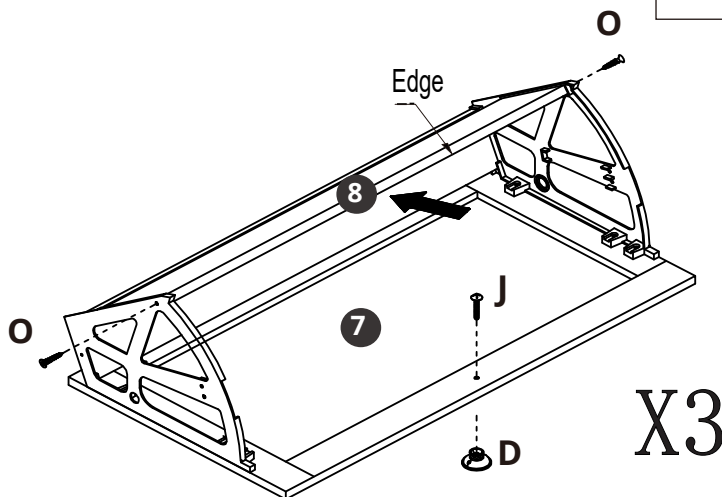

O		6	
J		3	
D		3	

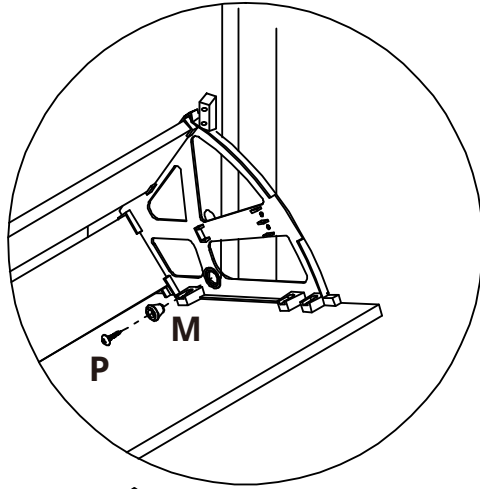

ASSEMBLY INSTRUCTIONS

Step 15



M		6	
O		6	
P		6	

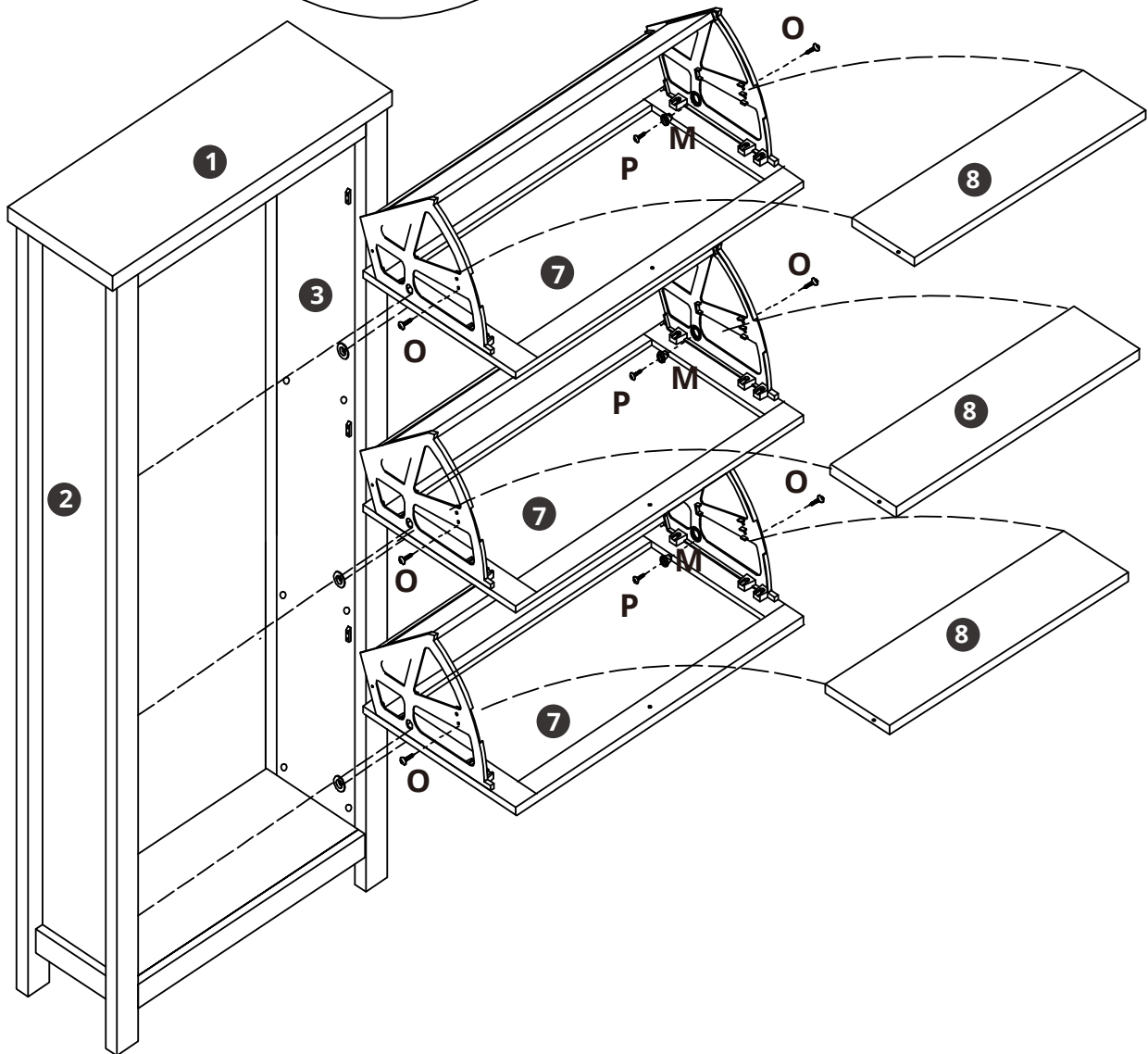

ASSEMBLY INSTRUCTIONS

Step 16

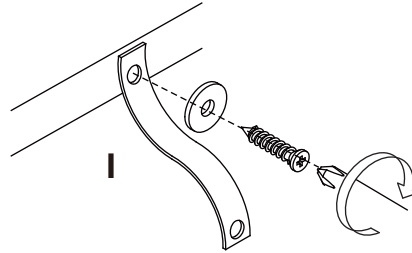
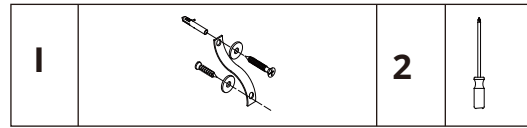
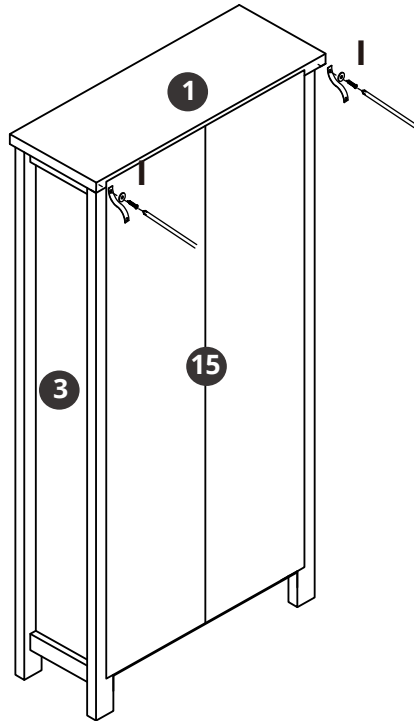

Step 17

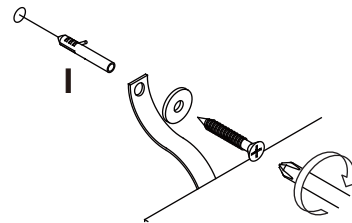
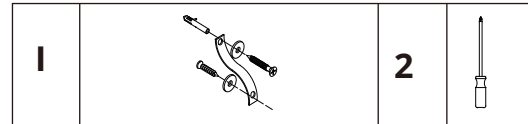
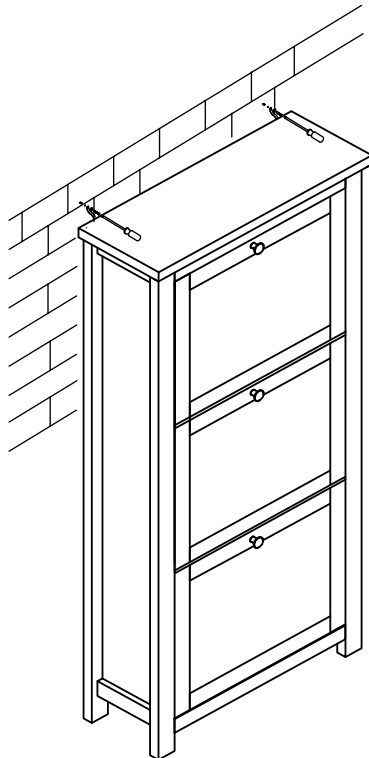

*Congratulations!
Now you have finished assembling the product.*

A Guide to - Wall Mounting & Fixings

Important note:

If plastic wall plugs are supplied with your product:



- these are only suitable for use in masonry walls.

If you are in any doubt about the correct wall plugs for your wall, seek professional advice.

Failure of the product due to using incorrect fixings is the responsibility of the installer.



Important: When drilling into walls always check that there are no hidden wires or pipes etc.

Make sure that the screws and wall plugs being used are suitable for supporting your unit. Consult a qualified person if you are unsure.

Hints:

- 1: **General rule:** Always use a larger screw and wall plug if you are not sure.
- 2: Ensure you use the recommended drill bit to match the wall plug and hole size.
- 3: Ensure you drill the hole horizontally, do not force the drill or enlarge the hole.
- 4: Take extra care when drilling high walls, ceilings and ceramic tiles. Ensure wall plugs are inserted beyond the thickness of the ceramic tiles to avoid the tiles splitting or cracking.
- 5: Ensure wall plugs are well fitted and are a tight fit in the drilled hole.

Types of walls

You can use one of the following types of wall plug if your walls are made of brick, breeze block, concrete, stone or wood.

No.1 "General Purpose" wall plug

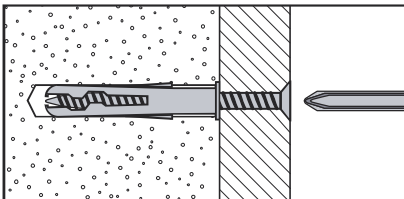

Generally aerated blocks should not be used to support heavy loads, use a specialist fitting in this case. For light loads, general purpose wall plugs can be used.

No.2 "Plasterboard" wall plug

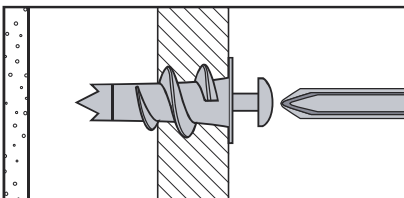

For use when attaching light loads on to plasterboard partitions.

No.3 "Cavity Fixing" wall plug

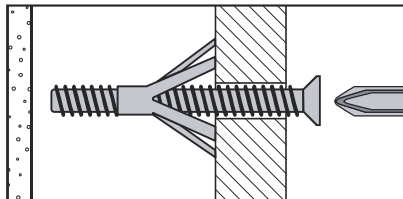

For use with plasterboard partitions or hollow wooden doors.

No.4 "Cavity Fixing-Heavy Duty" wall plug

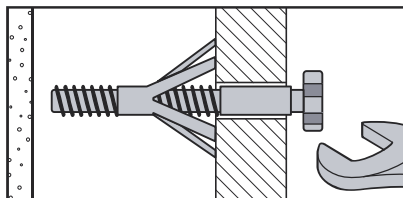

For use when fitting or supporting heavy loads such as shelving, wall cabinets and coat racks.

No.5 "Hammer Fixing" wall plug

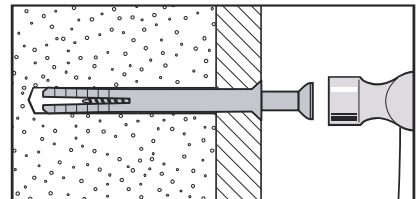

For use with walls stuck with plasterboard. The hammer fixing allows it to be fixed to the wall rather than the plasterboard. Always check the fixing is secure to the retaining wall.

No.6 "Shield Anchor" wall plug Heavy loads

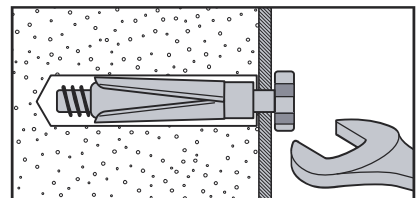

For use with heavier loads such as TV & HiFi speakers and satellite dishes etc.



Care & Maintenance

Safety: Always check the fitting and location to ensure your safety in and around the home.

Fitting: From time to time check the fitting to ensure the wall plugs or screws do not become loose.