

ASSEMBLY INSTRUCTIONS

EVIE ACCENT CHAIR

Thank you for purchasing the Evie Accent Chair
Please read the instructions carefully to ensure safe operation of this product

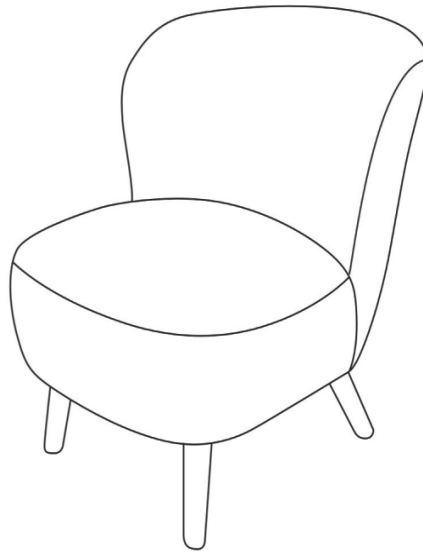

Size : W57 X D65 X H70cm

PLEASE READ this sheet prior to assembly to familiarise yourself with the various shapes of construction.

Carefully open the pack supplied and check the contents against the parts and fittings check list. Do not destroy any of the packaging until you are certain that you have all the necessary parts for the assembly.

CAUTION: There are small components used in the construction of this unit. These loose items should be kept away from young children whilst assembling your unit to avoid the danger of choking.

Tools Required



Allen Key
(INCLUDED)

Number of people

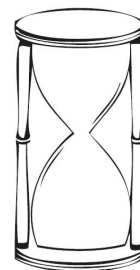

20 Minutes
Set Up

Batch No. V1 06/25

Page 1 of 7

EVIE ACCENT CHAIR

**IMPORTANT - READ CAREFULLY
RETAIN THESE INSTRUCTIONS FOR FUTURE REFERENCE.**

INFORMATION

- Due to the size of this product we recommend that it is assembled in the room intended for use.
- When you are ready to start, make sure that you have the right tools, plenty of space and a clean, dry area for assembly.
- Unwrap all packaging materials carefully and dispose of responsibly once the assembly is complete.
- Check the hardware pack and make sure you have all the parts listed.
- Ensure that this product is fully assembled as illustrated before use.
- Check all screws or bolts are tightened and inspect regularly.
- This product should only be used on firm, level floors.
- Tools are included.

WARNINGS

- DO make sure all the legs remain in contact with the ground.
- DO keep small parts out of reach of children.
- DO NOT use power tools to construct this product.
- DO NOT tighten screws until fully assembled and legs levelled.
- DO NOT over tighten screws or bolts.
- DO NOT use this product if parts are missing, damaged or worn.
- DO NOT stand on the product.
- If you have wooden floors, it is recommended that the use a protective felt on the feet of your new furniture to prevent scratching. NOTE. Protective felt is not supplied.

UPHOLSTERY CARE INSTRUCTIONS

- Never use scourer's, abrasives, chemical cleaners or harsh detergents which include bleaching agents to clean your upholstery as these may damage or bleach the fabric.
- If you spill something on your upholstery, blot up the excess immediately and gently wipe using a soft cloth or sponge and warm water with a mild detergent until the spillage is removed .
- Blot remaining excess with a clean dry towel and Allow to dry naturally.
- Remove dust weekly or monthly with your vacuum's upholstery or drape attachment, making sure that you vacuum under cushions to remove all dust and dirt. Try to avoid brushing fabric covers, as that can damage the pile.

What you can do to prolong the life of your upholstery

- Draw your curtains. If you avoid overexposing your furniture to sunlight, it will help to prevent colour fading.
- Vacuum your sofa or chair weekly or at least once a month to remove dust and dirt.
- Have fixed cover fabric chairs professionally cleaned at least once a year.
- If moving your furniture, lift chairs by their bases to protect the frames. Do not drag or pull by the arms.

Tips to prevent damage or harm

- Do not place your new furniture near to direct heat or air conditioning. chairs should be at least 50cm from radiators and other sources of heat, as heat can damage upholstery,
- Do not sit on the arms of a sofa or chair as it will damage the frame. Also try to avoid sitting on the edge of cushions.
- Beware of scissors, keys and other sharp objects that could tear or cut upholstery or scratch leather.
- Beware of the damage that can be caused by pets, such as scratching and chewing. Damage caused by pets is not covered by your warranty.
- Be careful of felt tip pens, highlighters, glue sticks and normal pens without caps. Ink is a stain that can only be removed by specialist cleaning.
- Try not to leave newspapers lying on your suite as newsprint ink is not fixed and can stain.

EVIE ACCENT CHAIR

Please check the pack contents before assembling the product.

If any components are missing, please contact your retailer.

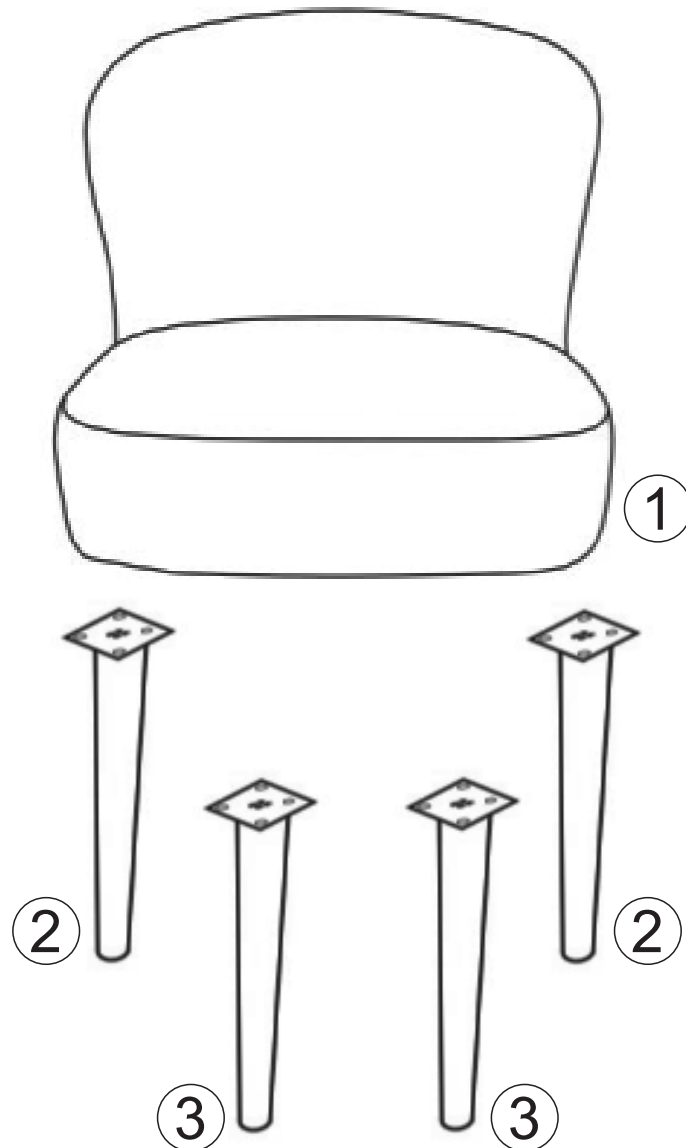

The fittings pack contains small items that should be kept away from children.



EVIE ACCENT CHAIR

Parts and Fittings Checklist

PARTS

1 	2 	3 
DESCRIPTION: SEAT QTY: 1PC DIMENSIONS: W57*D66*H49.5CM	DESCRIPTION: LEGS(BACK) QTY: 2PCS DIMENSIONS: D4.2*21CM	DESCRIPTION: LEGS(FRONT) QTY: 2PCS DIMENSIONS: D4.2*21CM

FIXINGS (TO SCALE)

Ref	Dimensions	Qty
A	BOLT (M6X20MM)	16

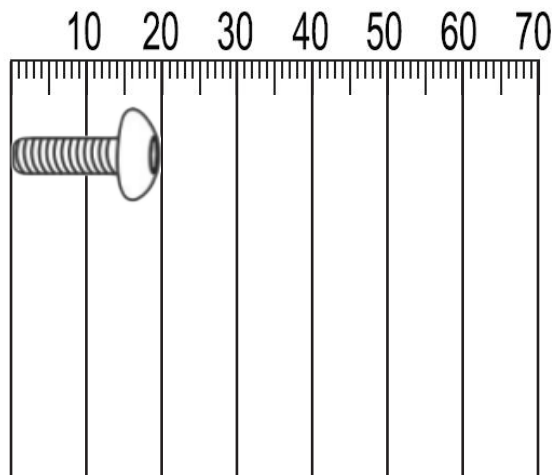

NOT TO SCALE

B	ALLEN KEY	1
---	-----------	---

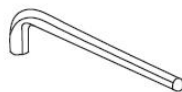

CAUTION: There are small components used in the construction of this product.
Please keep these components away from young children whilst assembling this product.

If you keep the fittings in a bowl during assembly you will be less likely to lose them!

EVIE ACCENT CHAIR

STEP 1

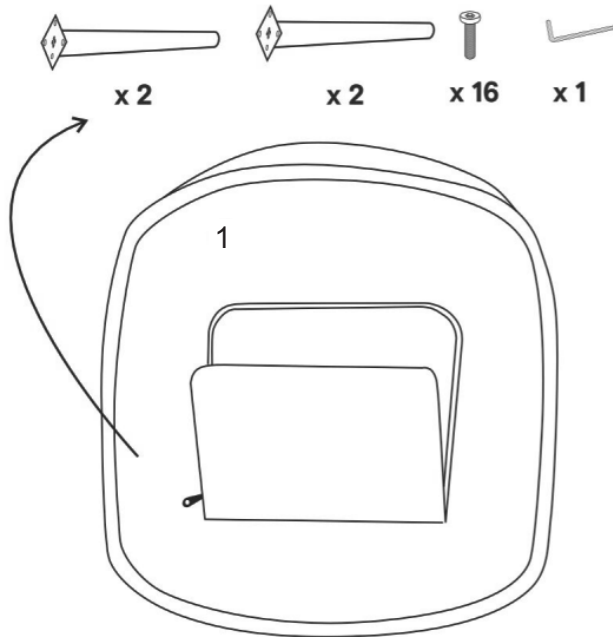

STEP 2

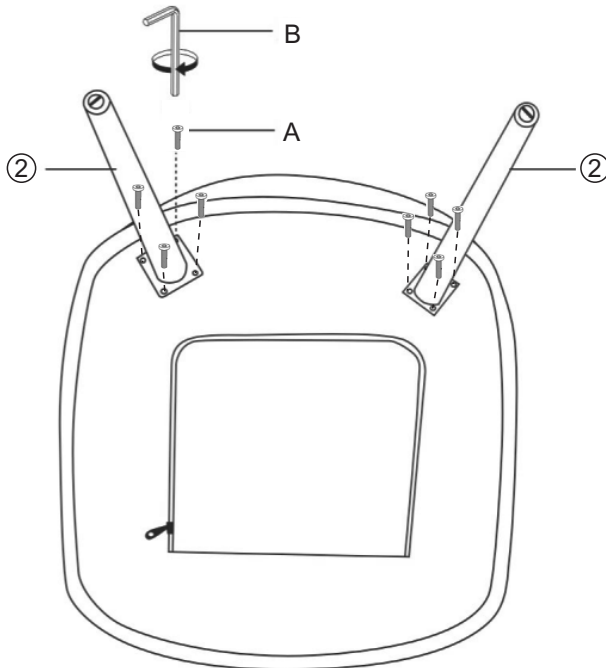

PARTS REQUIRED

- 1:SEAT X 1
- 2:LEGS(BACK) X 2
- A:BOLT X 8
- B:ALLEN KEY X 1

EVIE ACCENT CHAIR

STEP 3

PARTS REQUIRED

1:SEAT X 1
3:LEGS(FRONT) X 2

A:BOLT X 8
B:ALLEN KEY X 1

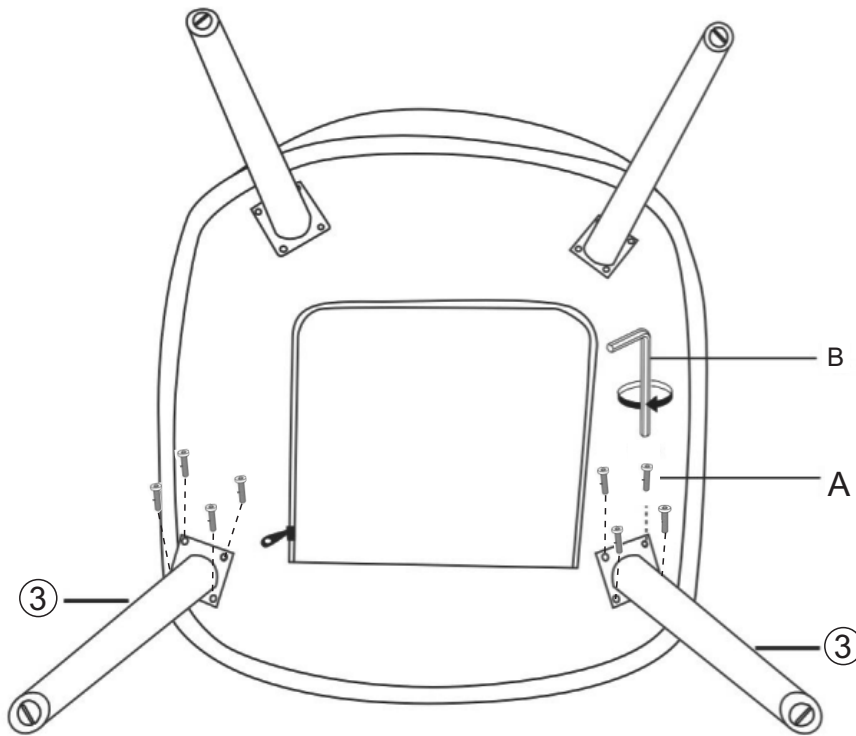

EVIE ACCENT CHAIR

Your **EVIE ACCENT CHAIR** is now completely assembled. Periodically check the legs to ensure the bolts are tight and secure. Should you find your chair has started to wobble first check that the floor surface is flat and even then repeat step 3 after first slightly slackening off the leg securing bolts.

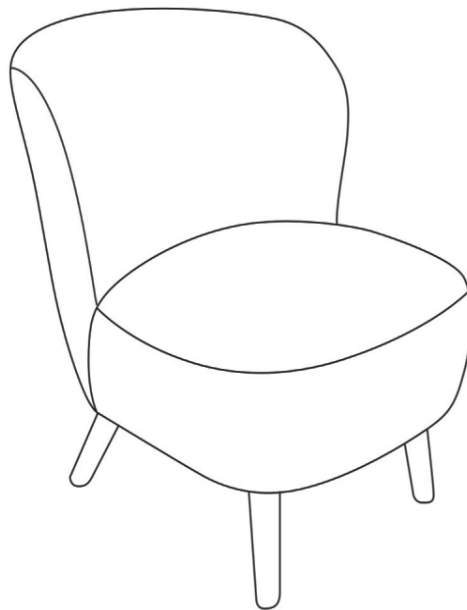

Retain these instructions for future reference.

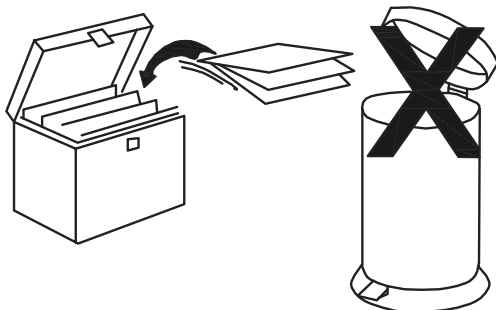

Supplied by : GFW THE FURNITURE WAREHOUSE
Waterside Distribution Centre
Waterside Business Park
Johnson Road
Lancashire BB3 3RT

Email: gfwlimited.co.uk