

DOOR INSTALLATION GUIDE



Welcome to your new door

Thank you for choosing a new energy efficient door from Lacerta. Your new door has been manufactured to the highest quality standards and is guaranteed for 10 years.

Your door will arrive unglazed and it is important that you stack the door in a vertical position - to prevent your door being damaged stack on flexible material between surfaces, such as wooden blocks.

Your door is delivered fully fabricated and should retain the protective film until all building works are complete.

Your delivery contains:-

- 1. Door** - the door will have corner blocks attached. These are there for protection - remove these prior to installation - see No 1.
- 2. Handle** - already attached to the door. This is fitted with handle mesh for protection - see No 2 .
- 3. Trickle vents** - these are taped to the door.
- 4. Glazing packers, cill and cill end caps** - these are in a plastic bag

Prior to installation please ensure that your new door has been checked for imperfections or any damage.

Please report any issues within 48 hours of delivery.



Protective corner blocks

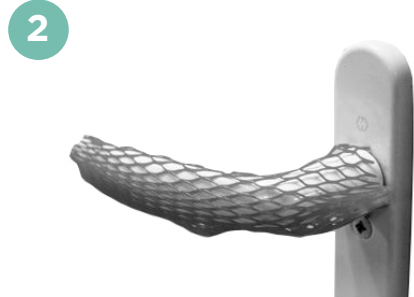

Door handle

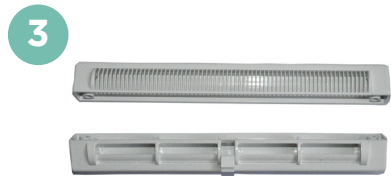

Trickle vents

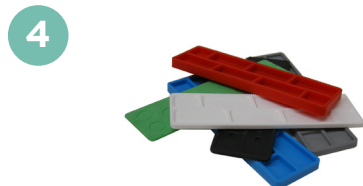

Glazing packers, cill and cill end caps

Fitting the new frame

1

Please read through all of this instruction guide before starting.

Remove the old frame

Once the old frame has been removed, brush away any loose debris or cement, leaving a clean opening ready to receive the new frame.

2

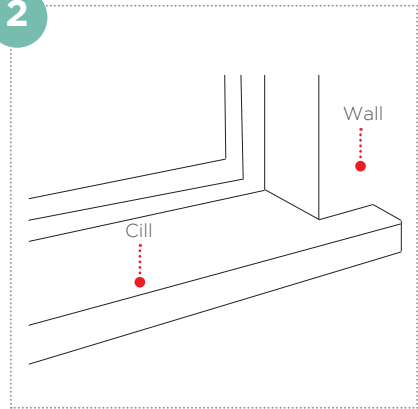

Frame with a cill

If you are fitting a frame with a cill, first decide if you are going to run the cill around the brickwork or cut it flush to the finished width of the hole (see above).

Whichever way you decide to do it, cut the cill to size with a fine toothed saw to fit tightly back to the inside edge where the old frame sat. You may have to remove the tongue of the internal window board first.

Affixing a cill

Once the cill has been cut to size, apply a line of sealant along the cill upstand and across the frame platform at each end. Screw them together, through the bottom frame section along the centre line and into the cill.

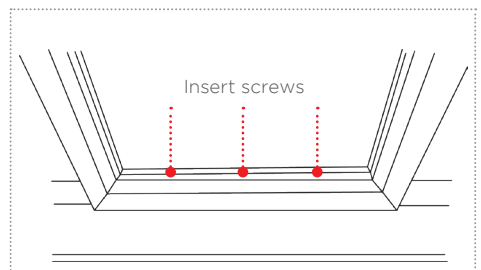

3

Expanders

Your new door should have a gap of around 5mm all around it to make sure it fits into the aperture - you can add frame extenders if you need to.

If your new door isn't quite big enough, you can add a total of 15, 20 or 35mm to the width or depth by attaching frame extenders.

Please note: Do not forget to remove the corner protectors prior to installation

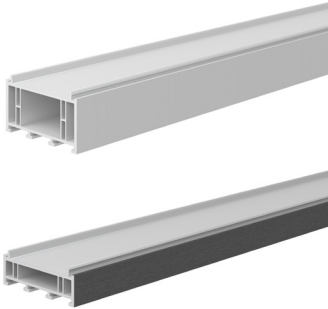

Expanders

4



Insert new frame

Offer the frame into the opening and using a spirit level, ensure the frame is level, vertical and not twisted before wedging into position.

Centralise it and insert packers underneath to level it and maintain the 5mm expansion gap.

5

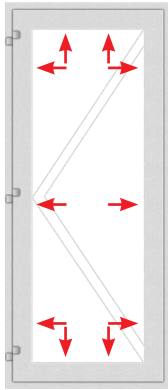

Affix new frame

1. Remove any packaging from the new frame and screw the cill onto the bottom of the frame. Make sure you select a screw that doesn't penetrate the inner skin of the frame.
2. Seal the ends of the cill and frame to prevent moisture tracking along the cills into the brickwork.
3. Position the frame into the prepared aperture. Centralise it and use packers to ensure that it is level and to maintain a 5mm expansion gap.
4. Once the frame is level drill fixing holes into the frame sides. These should be drilled 150mm from the top and bottom corners and 600mm in between (a minimum of 2 fixings per side).
5. Fix the side of the door frame to the wall. To avoid distortion to the frame and maintain the 5mm expansion gap use packers (do not overtighten the fixings).
6. On wider frames ensure you fix the top and bottom of the frames. Ensure that the top and bottom fixings are sealed with silicone to prevent moisture absorbing into the brickwork.
7. When finished ensure you clean any brick dust from your new door frame.
8. For optimum thermal and acoustic performance, it is critical that the gap between the door product and the aperture is fully insulated using a suitable expanding foam or expanding foam tape.

Glazing

1

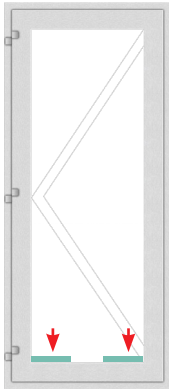

How to glaze the new door

Starting with one of the longest beads first, remove the glazing beads by pushing a sharp chisel or a rigid paint scraper between the bead and the frame joint at approximately the centre point. A sharp tap on the butt of the tool should allow the bead to be freed. It is most important to refit the beads in the same positions as they were removed, they may vary in length slightly, due to the manufacturing process.

1. Place into position the glass packers approximately 100mm in from each corner (intermediate packers should be used if the double glazed unit is wider than 1200mm).
2. Place the double glazed unit into the frame ensuring correct positioning on the glass packers.
3. Starting on one of the shortest lengths, fit 3 of the beads moving around the frame using a rubber mallet, finally fitting the last bead by bending it into position.

N.B. It is always best to leave one of the longer beads until last as a long bead will locate and bend more easily.

2

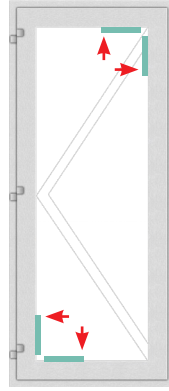

Toeing and heeling

PVC-U opening doors (sash) are heavy, and although the dead weight is supported on the hinge side when it is opened, there is nothing on the lock side to support the weight, and without the procedure of toeing and heeling the door will drop on the handle side. To prevent a sash dropping, the glass has to be braced diagonally corner to corner (see diagram) by the insertion of plastic packers slipped in the gap between the glass or panel and frame.

How to toe and heel

The door or sash on the lock side should be raised to the desired height and squared up with the door frame. On the hinge side place the packers at the bottom corner, whilst on the lock side, the packers go at the top (opposite) corner - place a dab of silicone under the packers on the door sides to stop the packers dropping. It is advisable to use a glazing shovel when lifting the glass or panel. The packers should be placed approximately 150mm from the edge of the frame.

Door hinge

Developed from criteria specifically set by the UK market, the programme for developing the ProSecure hinge range took into account security, adjustability, long service life and reliability without compromising on aesthetics.

- Superior aesthetics and performance
- Fit and forget - eliminates remedial work on sagging doors
- Custom designed sash plates for all leading profile systems
- Low profile hinge stack, eliminating damage to plaster reveals and decorations
- Makes safer, simpler, door lifting possible - installation can be completed by a single operative
- Fixed gasket pressure - weather seal always remains exactly as preset in the factory so that on site installation errors are eliminated
- Dog-bolts are not required
- Constant 4mm adjustment space - no need to adjust top pin in relation to bottom pin

Hinge adjustment detail is found on the surface of the hinge

Patio door installation & assembly instructions

1

Installing the frame

Fixing the Cill :-The method shown requires the cill to be fitted to the base of the opening making sure that the base is clean of loose debris and the DPC is intact, apply silicone bed as shown, making sure that the cill is level. Then fix with the appropriate

frame fixings 200mm from each end at a maximum of 600mm centres (In accordance with BS 8213-4:2007). Finally fix frame to cill using 50mm self tapping screws.

Note:- For PAS24 fixing centres should be reduced to 100mm from each end and at a maximum of 300mm pitch.

Fixings through the cill

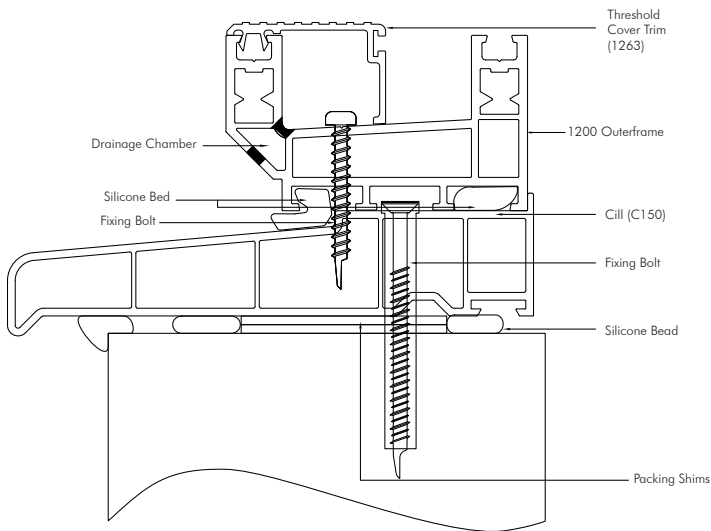

2

Fixing the Assembled Frame

N.B: It is better not to remove the fixed or sliding sashes from the outer frame prior to fixing. However on very large three or four pane units, it will make lifting easier if the sliding door/s are removed. The sash end cover profile

(1289) will need to be removed in order to lift off the door/s.

IMPORTANT - Do not remove the fixed sashes, as these will not lift back in once the outer frame head and cill are fixed.

Carefully remove the outer frame cover trims to allow access for fixing bolts.

External (Outside the slider)

Remove head trim first using a sharp wide bladed tool to ease between the front lip and outer frame to gently work trim free. Remove jamb trim next working from the top. Finally remove aluminium threshold trim - N.B.: If this is removed before the jamb trim, it will scratch the surface of the plastic.

Internal (Inside the fixed sash)

Either - Remove bump stops and jamb trim OR unscrew fixed sash and slide back.

The cill should be packed and set level on a silicone or mortar bed and fixed to the base of the opening. Before doing this it is advisable to offer the frame in "dry" to ensure that there is sufficient tolerance to fit the frame square and plumb.

When ready to fit the frame, run a line of silicone to the top face of the cill and offer the frame back into position.

Use temporary wedges to set the frame square in the opening (use diagonal measurement across opposite corners of the outer frame to check).

Fix the bottom frame and cill first using fixing bolt centres.

Next pack and fix jambs plumb and true.

Fixings should be 200mm from top and bottom corners and no more than 600mm centres in between.

On the locking jambs, the intermediate fixings should be adjacent to the locking points.

The head can now be fixed using the same fixing distances as jambs. However, if head fixings are impracticable, and additional foam fixing is used (in accordance with BS 8214-4:2007), then fixings can be as described in 'Fixings Through Cill' section. Ensure that head is fixed level with no bow in either plane.

Re-fix the fixed sash/es if they were moved for jamb fixings. Ensure that the fixing to the head does not distort the frame, use packer (1204) between the fixed sash and outer frame.

Re-fit the jamb cover trims using the removal method in reverse. Cut and fit the drainage trim into the threshold behind the fixed sash.

Finally check that the door locks properly and is secure. Ensure that the location pin on the lock, just above the handle set, is centred on the hole provided in lock plate.

To check for plumb, slide the door almost closed, leaving a small gap. If the gap is not parallel, make any necessary adjustment by raising or lowering the rollers using a posidrive screwdriver, gaining access from the end of the sash (on the interlock side, part remove sash end cover).

3

Glazing

Bridge packers (1975) should be positioned and glazing packers should be glued into position as shown, also additional security packers should be glued in position to the back of the intermediate locking points. Care should be taken not to bow the stiles of the sashes. Glaze up the fixed panel first as access is required through the slider to bead up the interlock stile.

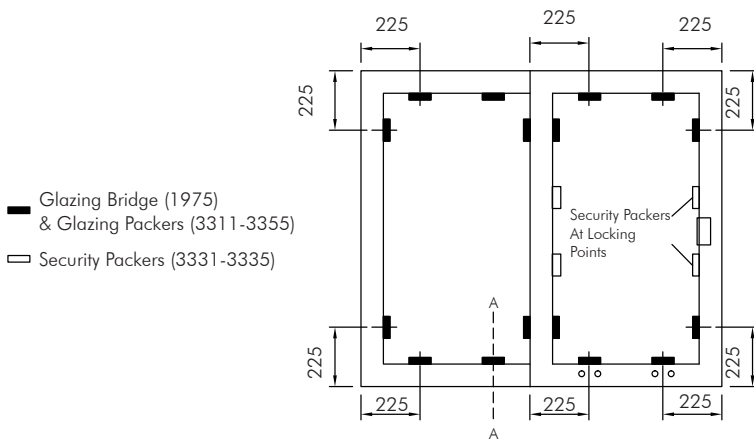

4

Perimeter sealing

It is advisable to clean down the frame before sealing the perimeter.

The gap between the outer frame and structure must be sealed using a suitable external grade sealant. 5-6mm gaps can be filled with sealant alone, however larger gaps may require the use of foam backing strips.

4

Assembling the frame

Fixed sashes

Stand the frame up against a suitable wall, and lift in the fixed sash/es by “springing” the head and cill in the middle of the frame.

At this stage the assembled frame can be installed into the structural opening.

Once the frame has been fixed, the fixed sash/es can be screwed to the outer frame through the pre-drilled holes using the 100mm tapcon screws supplied. Fit the brush sealing pads into the outer frame, centred above and below where the sashes couple together.

Bump stops

Locate the back of the bump stop into the dovetail channel of the outer frame upstand and with a rubber mallet secure into position.

Trims

Fit the jamb cover (1253) trims first, then fit the head (1253) and black threshold (1263)* trims using a rubber mallet to tap trim into the outside dovetail. Next fit the dovetail closure profile(1254) to the inside head dovetail and fit the stainless steel track to the inside dovetail at the bottom using a rubber mallet. Finally to cover drainage hole detail - insert Drainage Cover Trim (1255) into the inside channel of the outer frame (Cill) section, behind the fixed panel.

*For (L) 1334 Low Threshold fit L1335 Threshold Trim.

Sliding Door(s)

Remove the sash end cover profile from the sash. Push the sash up into position at the head and lift the bottom over the track and let the sash drop into position on the track. Fit the handle set on the sash checking that the lock is in the unlocked position and the lever on the handle set is positioned as shown.

Once the final adjustments to the door have been completed and you have checked that the door locks correctly, you can replace the sash end cover profile.

Meeting Profile (3 and 4 pane doors only)

Adjust both doors so that they are square and parallel with each other. Cut the meeting profile 16mm shorter than sash height. Fix centrally to meeting stile of slave door using 55mm screws supplied. Fit end caps (1270) to top and bottom of the sash meeting profile using a proprietary PVC-U glue. Fit lock plate as stated.

Lock Plate

Slide the door to a closed position. Mark the lock centre, as shown on the lock face plate, on the outer frame (for 3 and 4 pane doors see meeting profile). Offer the lock plate to the outer frame, making sure that the end caps are fitted, and line up the lock centre line with the horizontal line on the centre of the hook lock keep plate (keeping the words Patimaster above and below the line. Fix using 8 off screws supplied. Fit closure profile (1254) above and below the lock plate

Check that the door locks correctly and is square within the frame. Make any adjustments necessary by raising or

lowering the rollers using a long shaft posidrive screwdriver, gaining access from the end of the sash. Fit the sash end closure profile.

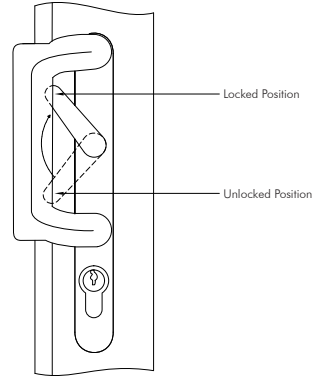

Finishing

Clean the external surfaces to remove the dirt and grit.

Apply a strip of masking tape to the frame perimeter. Apply a smooth bead of silicone sealant between the frame and brick work. Before the sealant sets, remove the masking tape to create a neat finish. It is important to remember to seal below the external cill.

Trims and profiles come in lots of different shapes and sizes to cover sealant and fixings. They'll give you a neat, professional finish, inside and out.

You can cover wider gaps around the outside of the door with a PVC-U scotia

trim. Do this by sealing the frame behind the trim with frame sealant. You can then stick the trim in place with more frame sealant.

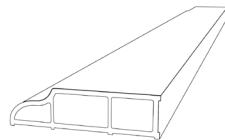

You have finished!

Once you have installed your new door, open and close it to ensure that it is working correctly.

Top tips looking after your doors

Our top tips to keep your doors in the best condition, we recommend...

- That you carry out routine maintenance on your doors at least twice a year. In areas of high exposure, you may want to do this more frequently.
- All parts of your new doors that are exposed when closed, should be washed down with warm soapy water using a soft cloth, then dried thoroughly.
- Any parts that are exposed when the door is open, should simply be wiped clean, removing any grime, dirt, insect remains or old lubricant.
- You avoid any cleaning agents that have ammonia in them or that are abrasive, particularly on handles and other metal fittings.
- Special attention is paid to keep drainage channels clear and free from any blockages.
- That any moving parts and fixings are treated as follows:
 - The application of light oil, to keep the locking mechanism in good working order.
 - A suitable acid and resin free grease should be used on sliding bars, gears and face plates.
 - Maintenance of friction stays is important and we recommend that you follow the guidelines for lubrication and adjustment.

Locking

To operate the lock, insert the key into the cylinder. Rotate the handle upwards and turn the key for one complete revolution to activate the deadbolt, which locks the whole mechanism. Release the handle.

Unlocking

Insert the key into the cylinder and disengage the deadbolt by turning one complete revolution. Depress the handle and open the door. Where a split spindle is fitted in addition, after you have depressed the handle, turn the key a further quarter revolution to release the latch.

Handle Options

Traditional front doors can be fitted with an external pull-pad operated handle with a lever operated internal handle. Back doors are usually fitted with a lever operated handle both internally and externally.

Maintenance of the locking systems is simple: apply light oil to the moving parts, once a year. Similarly, a little grease should be applied to the locking slots to facilitate smooth running.

Warranty

Your new product carries a manufacturer's warranty of 10 years.