



# WRENSBURY BED

## ASSEMBLY INSTRUCTIONS

### **IMPORTANT:**

Please read this manual carefully before beginning assembly of this product. Keep this manual for future reference.

### **SAFETY INFORMATION:**

This item may contain small parts which can be swallowed by children and pets. Keep children and pets away whilst assembling. To avoid danger of suffocation, always keep plastic bags away from children and pets.

This product has been constructed to be used in the domestic environment only and not for commercial purposes.

Ensure that you have enough space to lay out all the components before assembly.

To avoid scratching, marking or damaging the product it is recommended that you assemble it on a carpet or soft surface.

We do not recommend the use of power tools for assembly as this could damage the unit.

### **CARE & MAINTENANCE:**

Wipe regularly with clean water and a damp, clean, soft white cloth.

General cleaning can be done as needed with a mild detergent and water solution. Always rinse with clean water and dry. For heavy soiling, dampen a soft white cloth or soft bristle brush. Use care as scrubbing can damage the surface.

More difficult stains can be treated, but this should be occasional, not daily, cleaning. Any cleaning solution used must be removed with clean water and a clean white cloth. Cleaning residue left on the material can cause it to dry out and crack, or affect the colour.



**DO NOT** use any cleaners with corrosive ingredients (i.e lye, acids, bleach or ammonia).



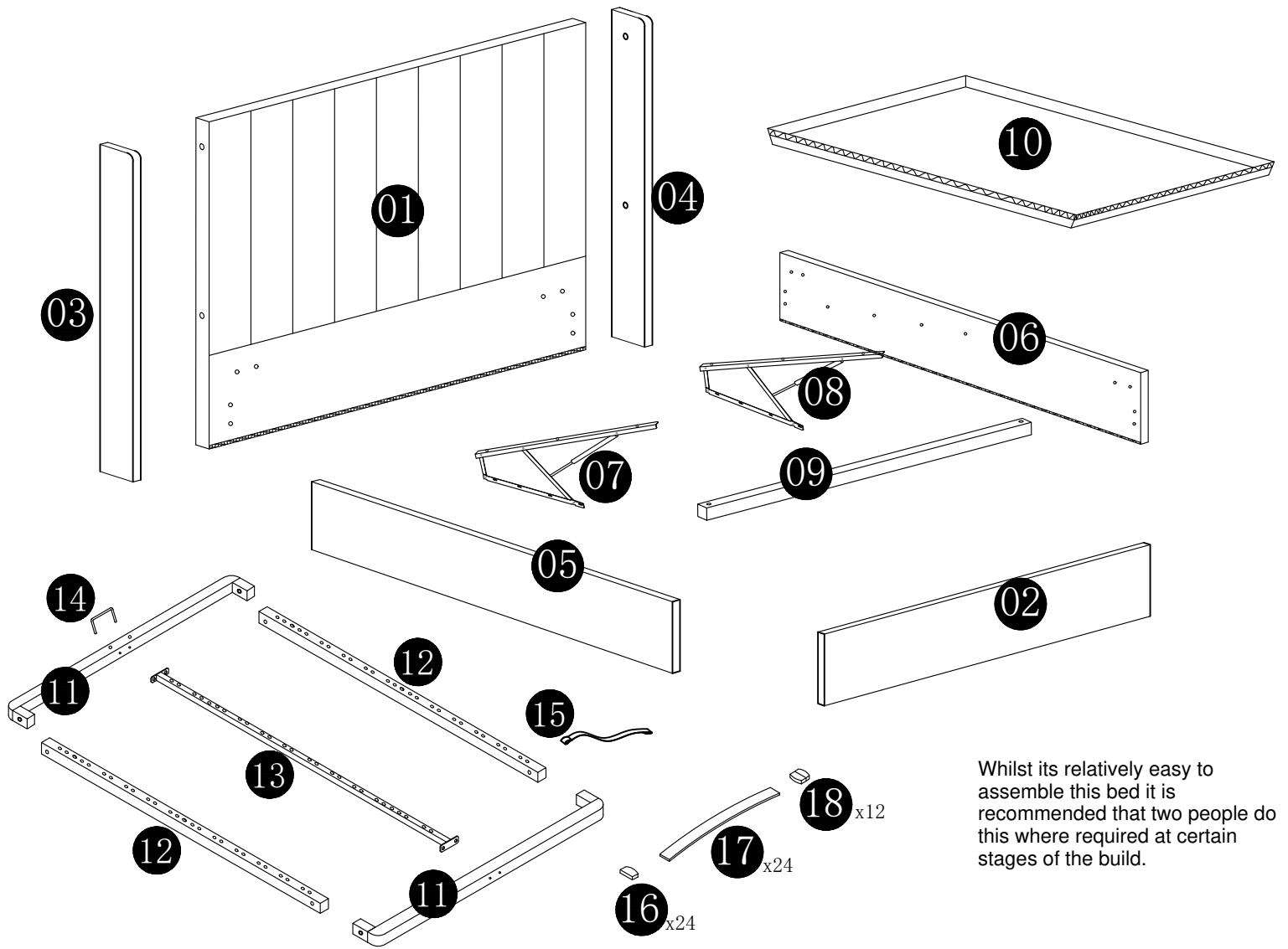

### **CAUTION:**

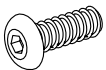

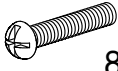
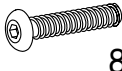

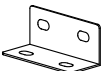
Beware of entrapment. Keep hands and fingers clear of mechanisms. Ensure that children or pets are not playing or lying in the way when the mechanism is operated.

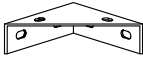

Whilst its relatively easy to assemble this bed it is recommended that two people do this where required at certain stages of the build.

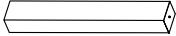
|   |  |    |
|---|--|----|
| A |  8*20   | 42 |
| B |  8*50   | 8  |
| C |  3.5*20 | 12 |
| D |  8*40   | 10 |
| E |  8*40   | 4  |

|   |   |    |
|---|---|----|
| F |  | 4  |
| G |  | 6  |
| H |  | 2  |
| I |  | 12 |
| J |  | 4  |

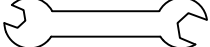
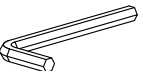
|   |  |   |
|---|--|---|
| K |  25.5cm | 2 |
| L |         | 4 |
| M |  2.5cm  | 4 |
| N |         | 1 |
| O |         | 1 |
| P |         | 1 |

We recommend that all parts are laid out in advance of assembling the bed & to familiarise yourself with the items.

01

Begin by taking the 4 metal bars that will make up the base of the ottoman frame and assemble as per images shown using the tools supplied. Don't completely tighten at this stage.

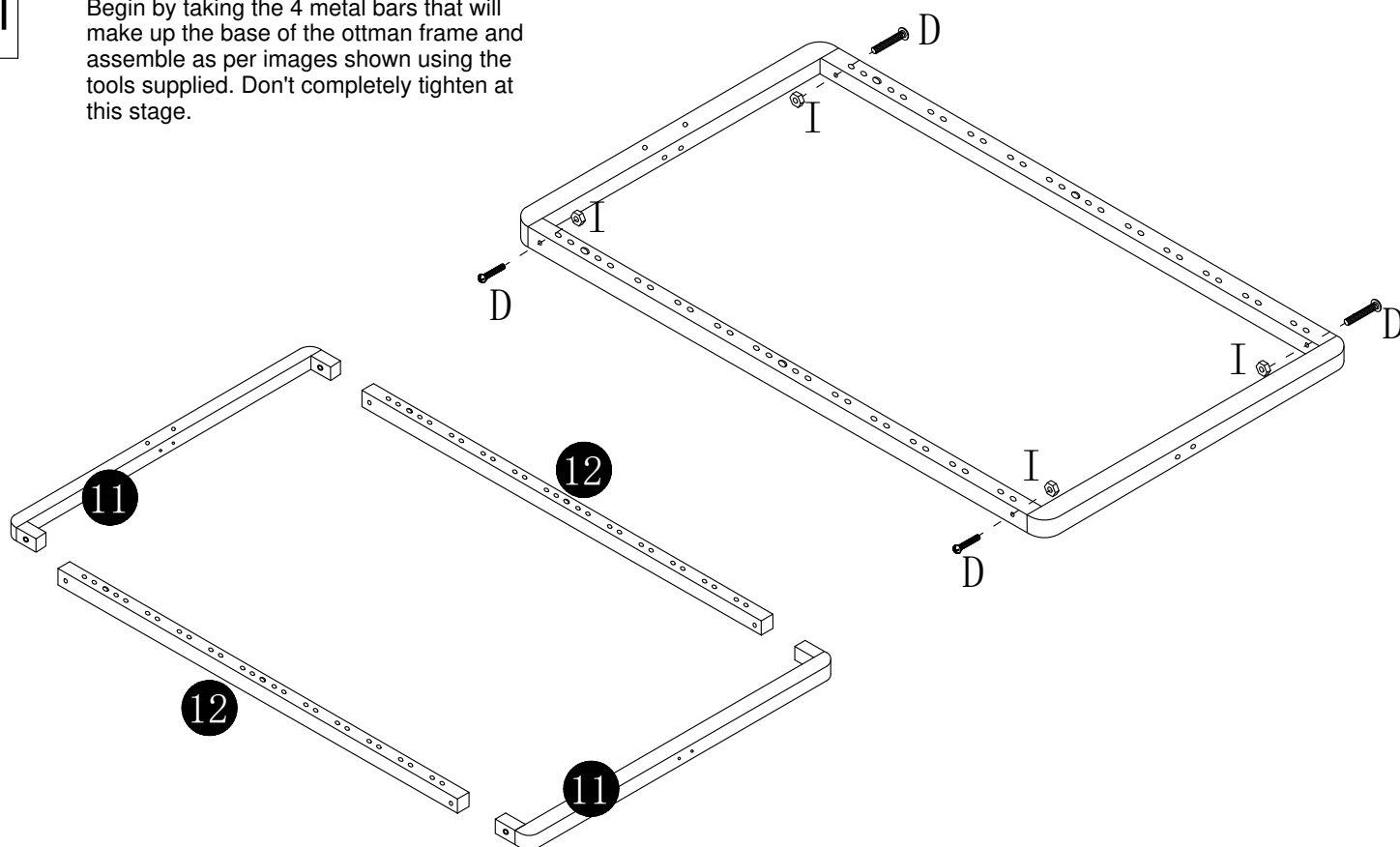

|   |  |   |   |  |   |
|---|--|---|---|--|---|
| 0 |  | 1 | N |  | 1 |
|---|--|---|---|--|---|

|   |  |   |   |  |   |
|---|--|---|---|--|---|
| I |  | 4 | D |  | 4 |
|---|--|---|---|--|---|

02

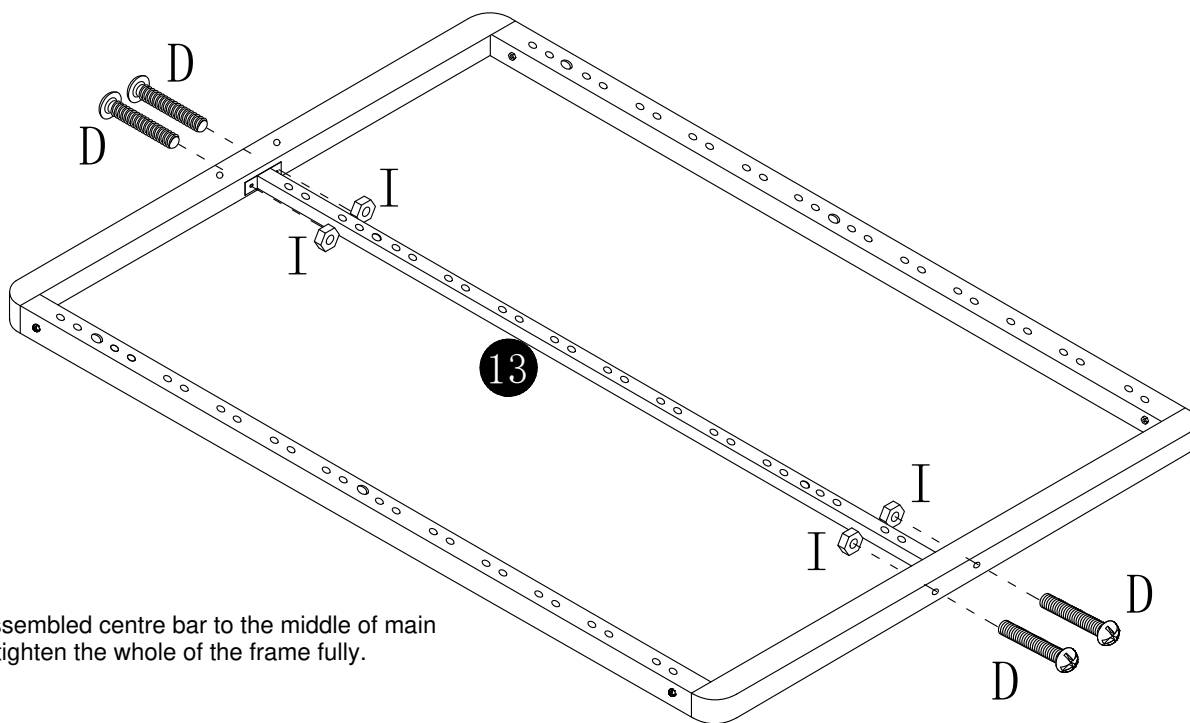

Attach the now assembled centre bar to the middle of main ottoman frame & tighten the whole of the frame fully.

|   |  |   |   |  |   |
|---|--|---|---|--|---|
| 0 |  | 1 | N |  | 1 |
|---|--|---|---|--|---|

|   |  |   |   |  |   |
|---|--|---|---|--|---|
| I |  | 4 | D |  | 4 |
|---|--|---|---|--|---|

03

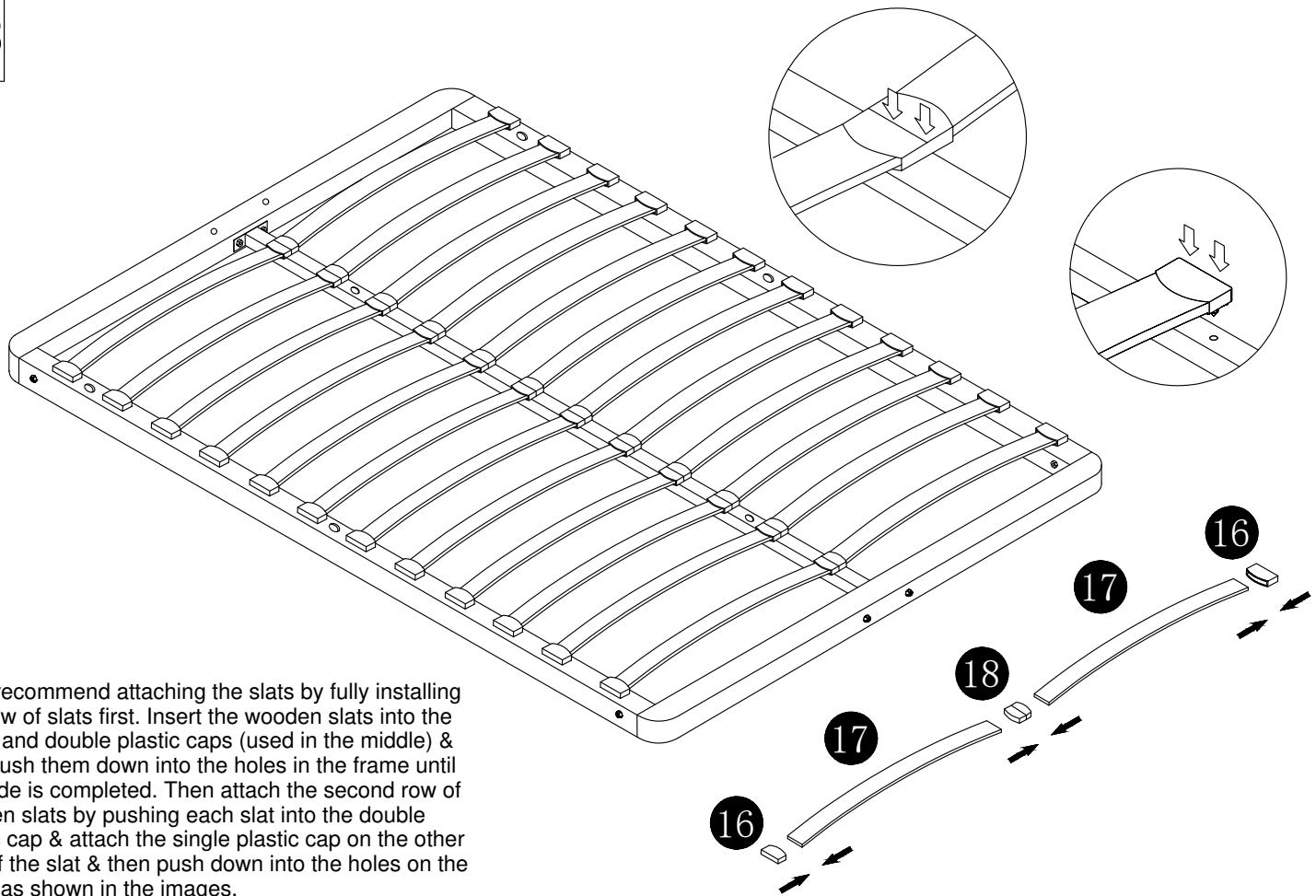

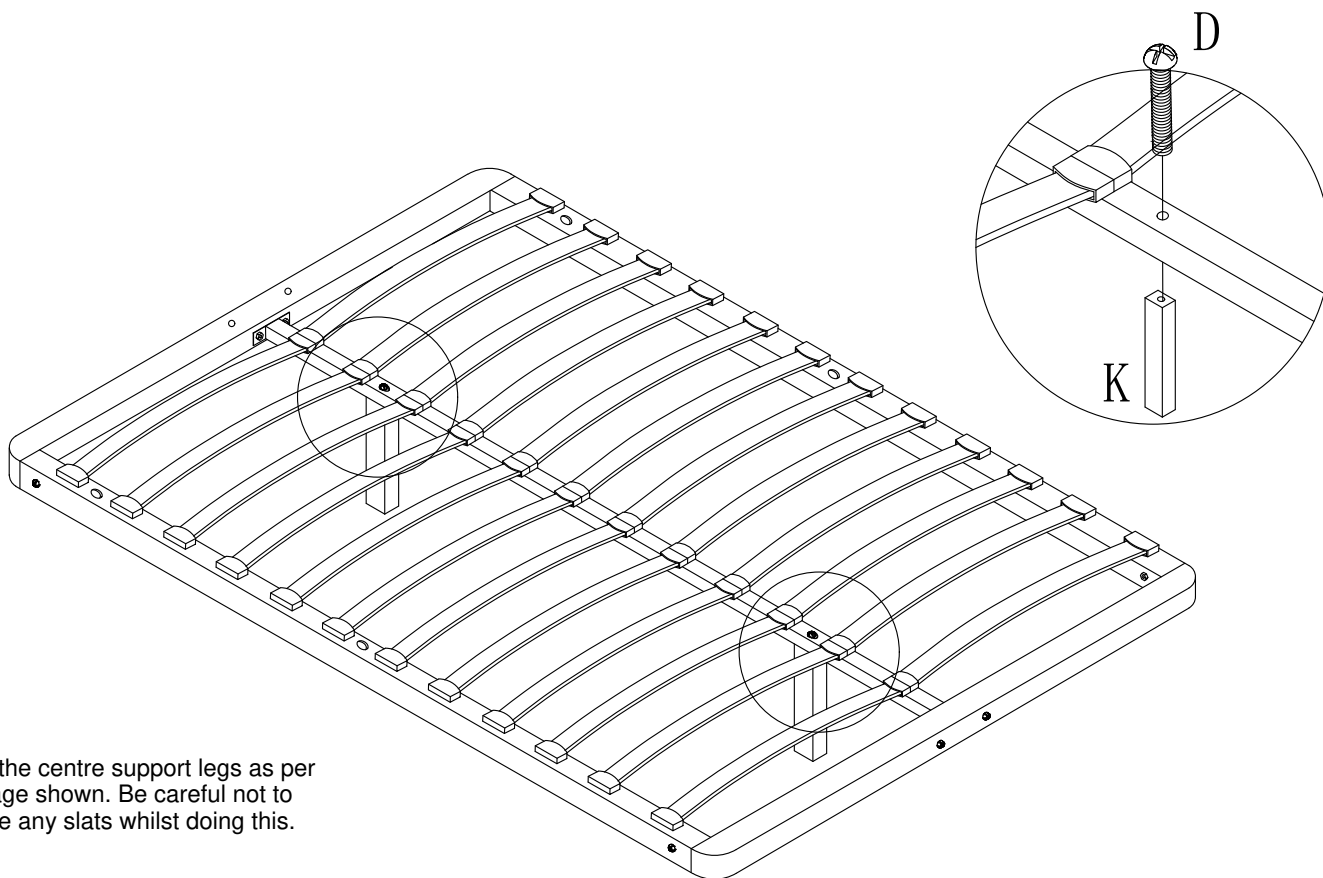

We'd recommend attaching the slats by fully installing one row of slats first. Insert the wooden slats into the single and double plastic caps (used in the middle) & then push them down into the holes in the frame until one side is completed. Then attach the second row of wooden slats by pushing each slat into the double plastic cap & attach the single plastic cap on the other side of the slat & then push down into the holes on the frame as shown in the images.

04

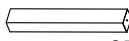

Attach the centre support legs as per the image shown. Be careful not to displace any slats whilst doing this.

|   |   |   |
|---|---|---|
| N |  | 1 |
|---|---|---|

|   |   |   |   |   |   |
|---|---|---|---|---|---|
| K |  | 2 | D |  | 2 |
|   | 25.5cm  |   |   | 8*40  |   |

05

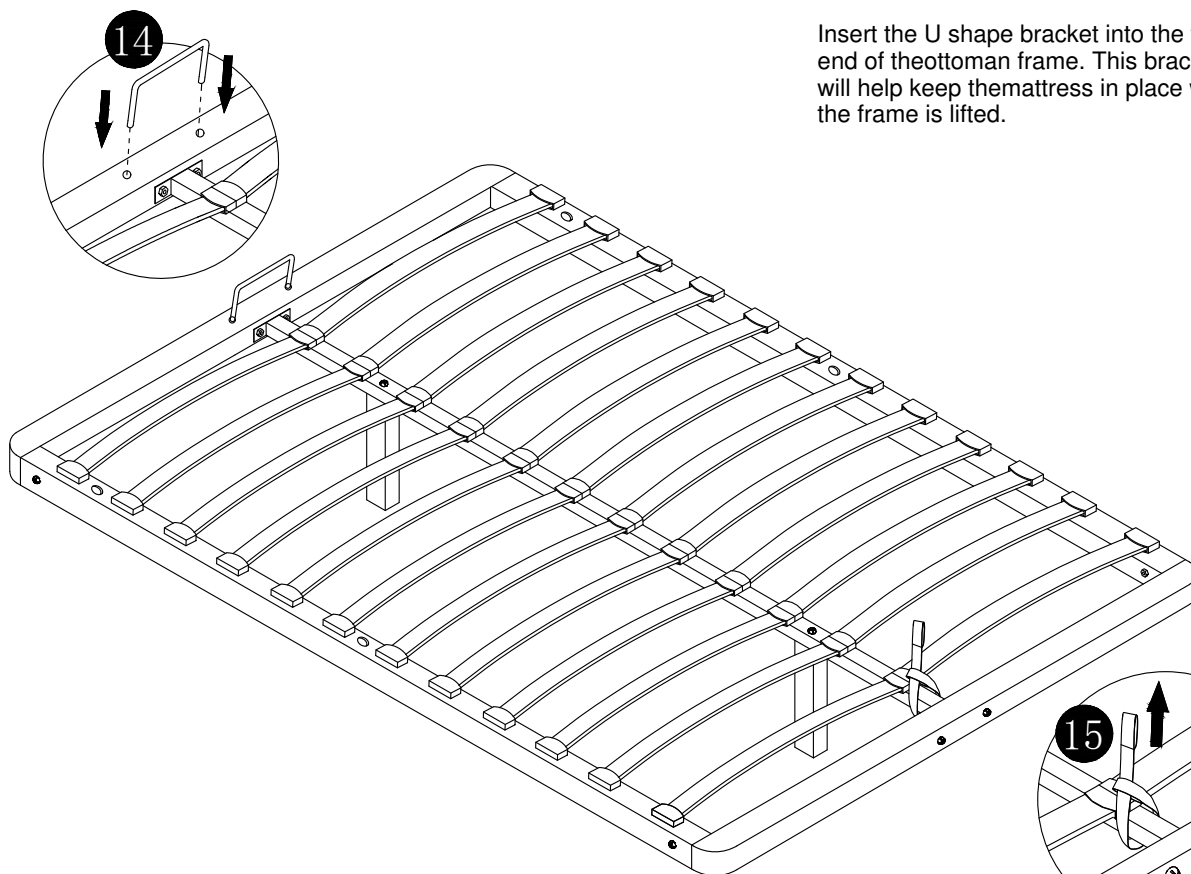

Insert the U shape bracket into the to end of the ottoman frame. This bracket will help keep the mattress in place when the frame is lifted.

At the opposite bottom end of the frame tie the fabric strap. The strap will be used to lift the ottoman frame when in situ.

06

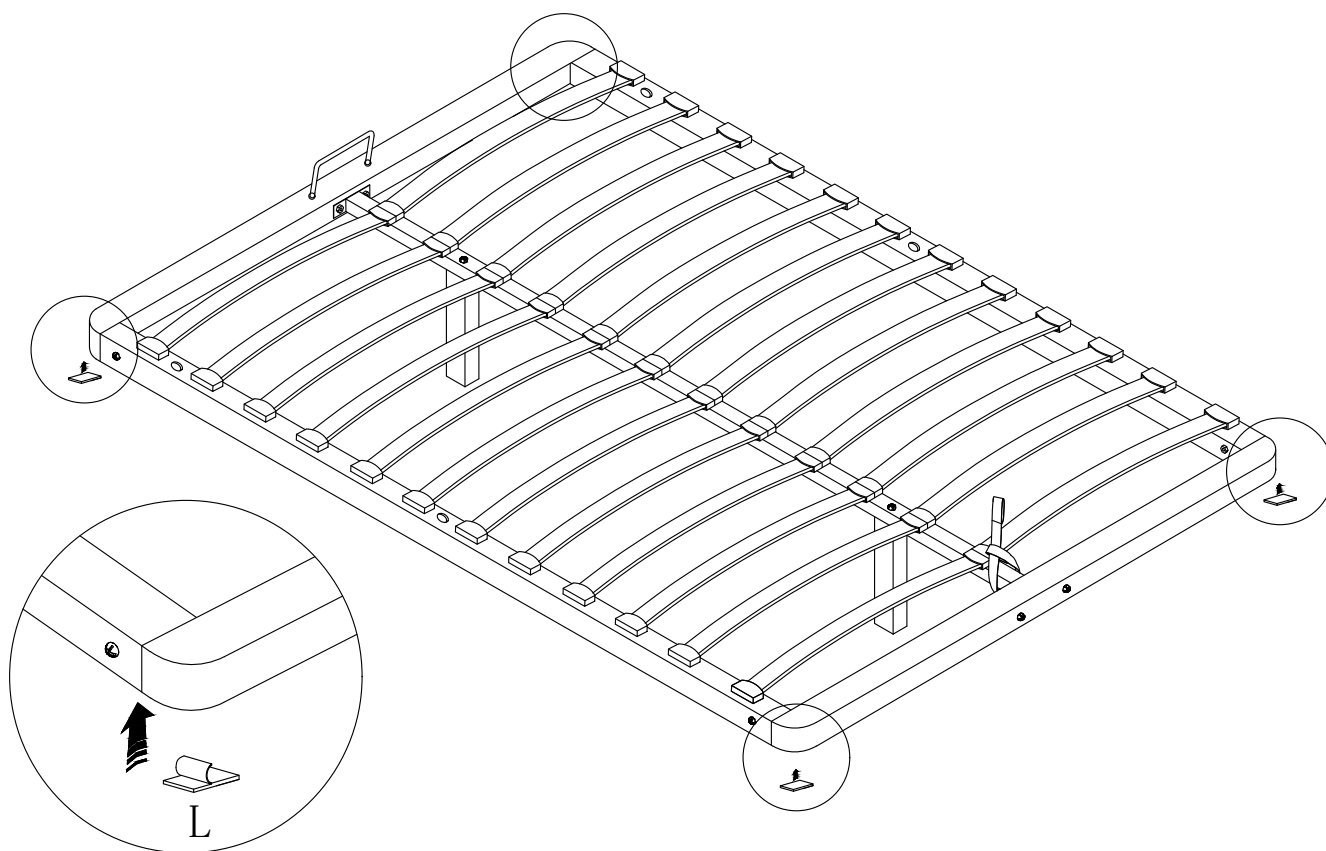

Attach the sticky sided pads to the underside of each corner of the frame.

07

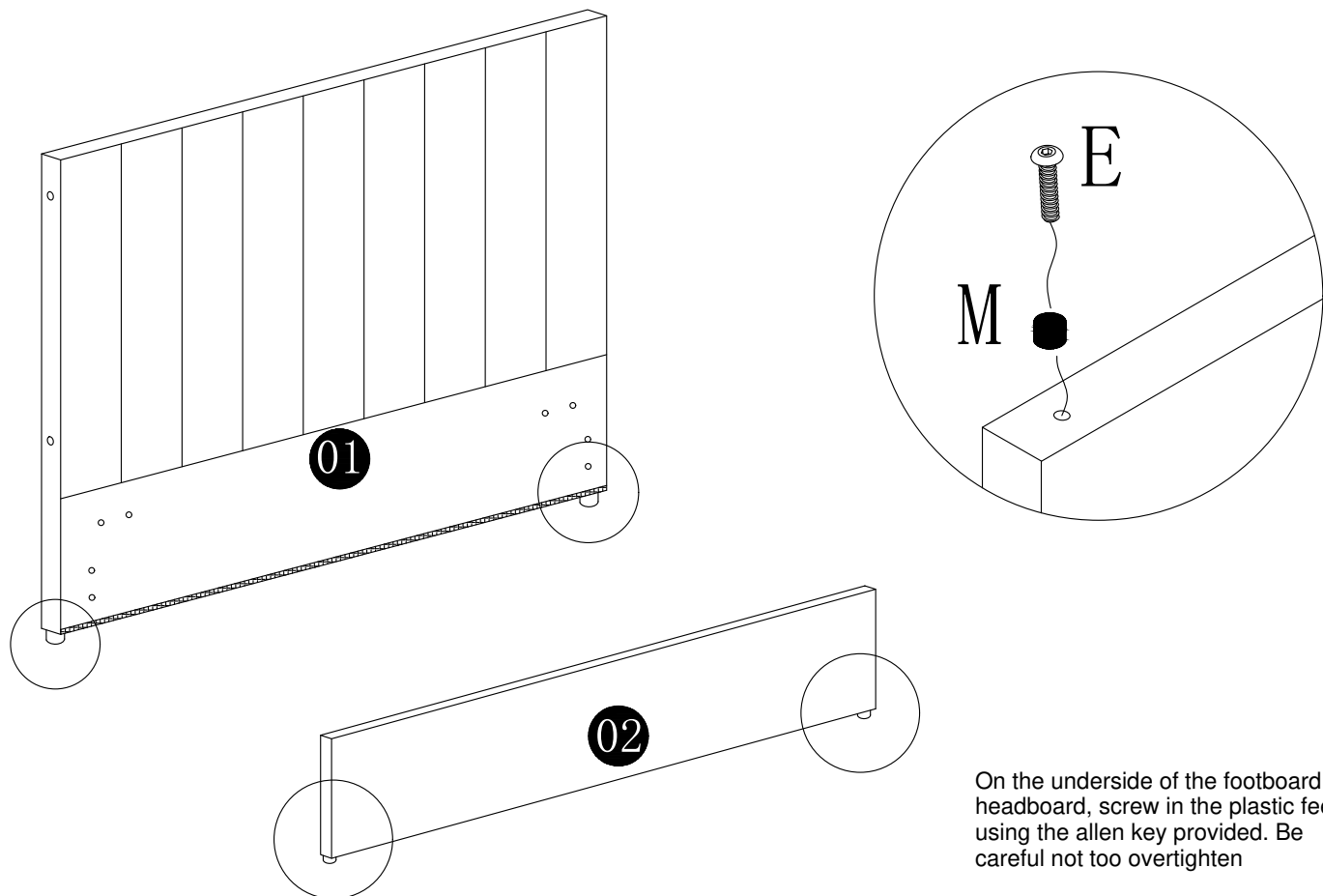

On the underside of the footboard & headboard, screw in the plastic feet using the allen key provided. Be careful not too overtighten

P

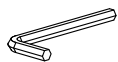

1

M



2.5cm

4

E

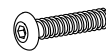

8\*40

4

08

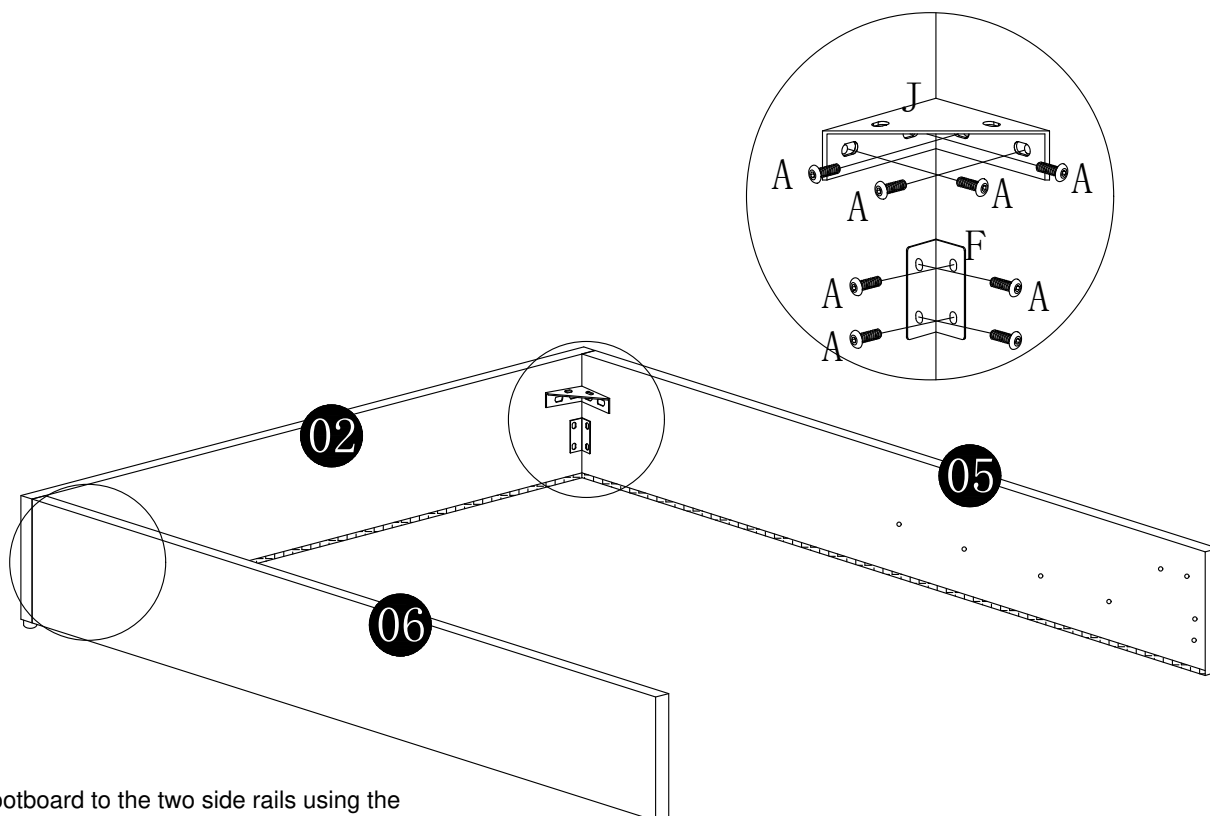

Attach the footboard to the two side rails using the respective corner brackets shown & the allen key provided. Tighten so secure whilst being careful not to over tighten.

P

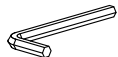

1

F



2

J



2

A





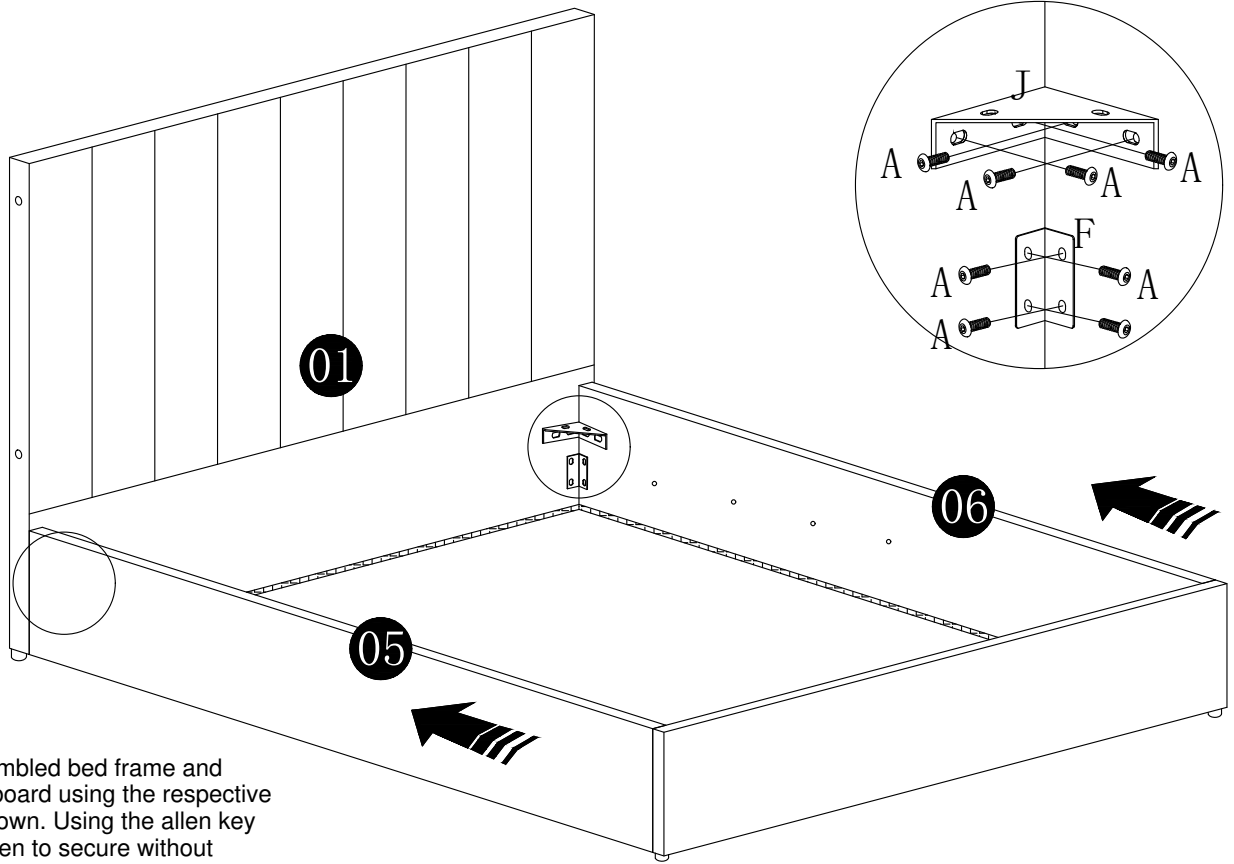

8\*20

16

09

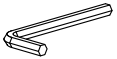

Now take the assembled bed frame and attach to the headboard using the respective corner brackets shown. Using the allen key provided, fully tighten to secure without overtightening.

|   |   |   |   |   |   |   |   |   |   |   |    |
|---|---|---|---|---|---|---|---|---|---|---|----|
| P |  | 1 | F |  | 2 | J |  | 2 | A |  | 16 |
|   |   |   |   |   |   |   |   |   |   | 8*20  |    |

10

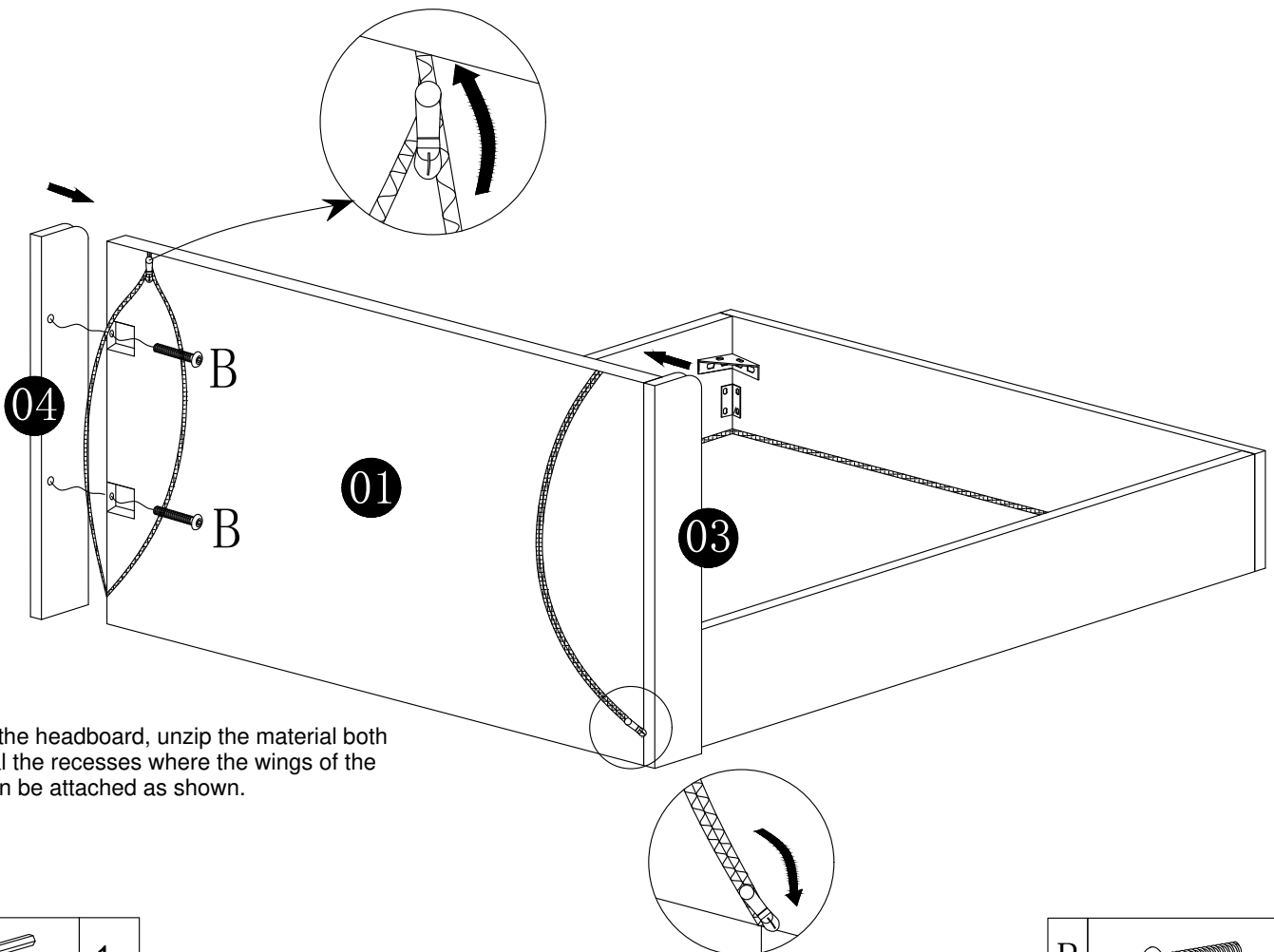

At the rear of the headboard, unzip the material both sides to reveal the recesses where the wings of the headboard can be attached as shown.

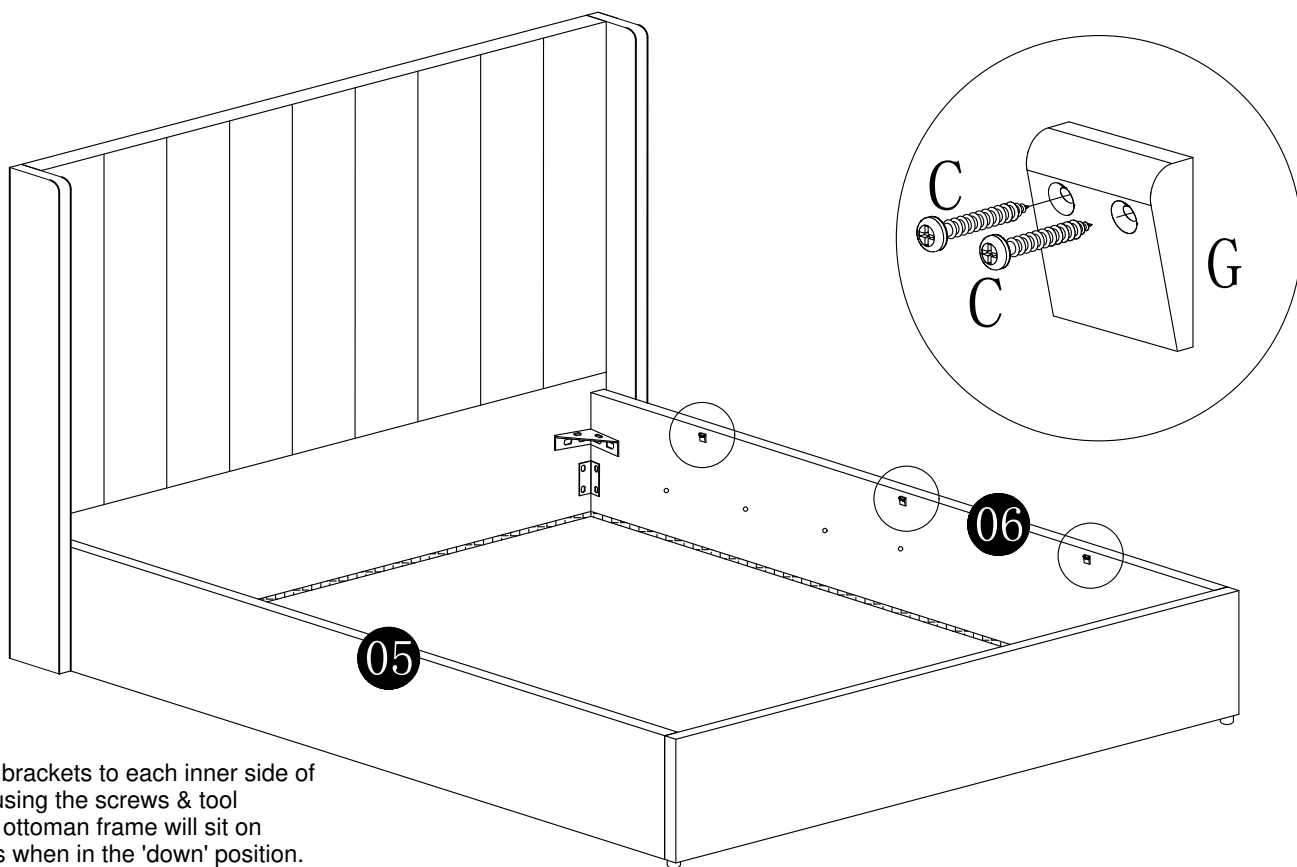

|   |   |   |   |   |   |
|---|---|---|---|---|---|
| P |  | 1 | B |  | 4 |
|   |   |   |   | 8*50  |   |

11



Screw the 6 x brackets to each inner side of the side rails using the screws & tool provided. The ottoman frame will sit on these brackets when in the 'down' position.

|   |   |   |
|---|---|---|
| N |  | 1 |
|---|---|---|

|   |   |   |   |   |    |
|---|---|---|---|---|----|
| G |  | 6 | C |  | 12 |
|---|---|---|---|---|----|

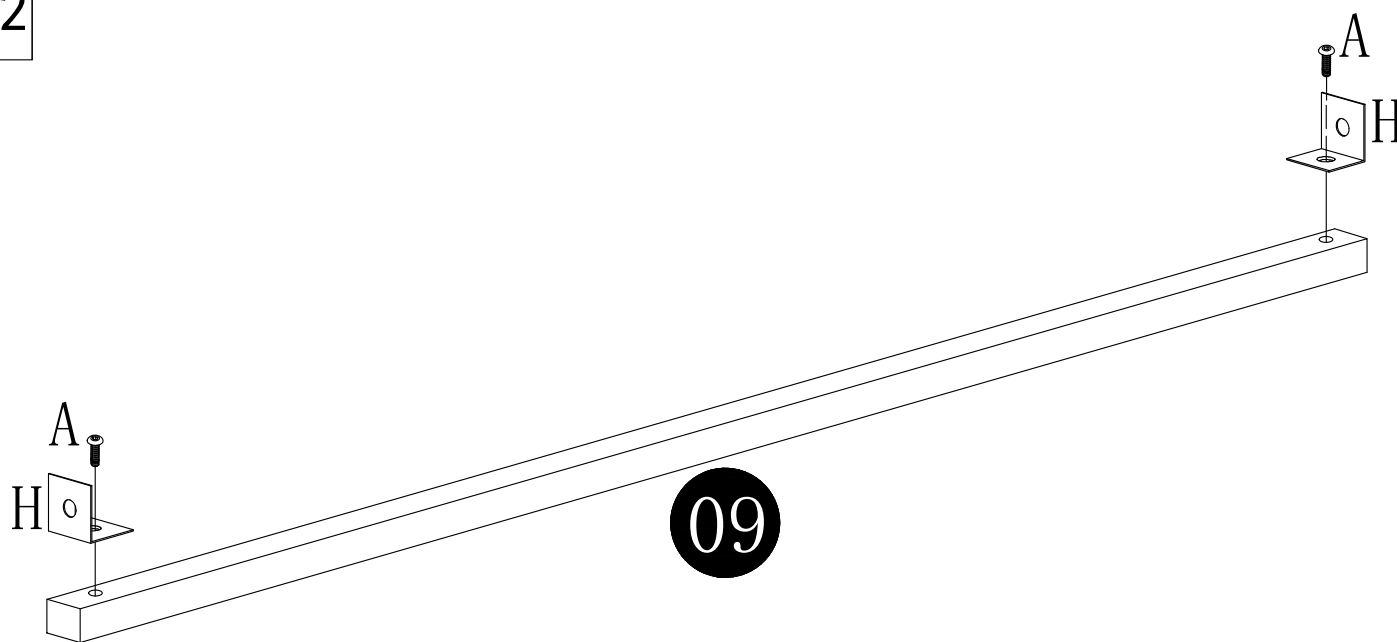

3.5\*20

12



Attach the 2 x L-shaped brackets to either end of the centre support bar using the allen key provided.

|   |   |   |
|---|---|---|
| P |  | 1 |
|---|---|---|

|   |   |   |   |   |   |
|---|---|---|---|---|---|
| H |  | 2 | A |  | 2 |
|---|---|---|---|---|---|

8\*20

13

Take the now assembled support bar & attach either end to the side rails & tighten. Now attach the ottoman frame support arm mechanisms to each side rail. Ensure that the bolts are located in the correct holes as shown in the image and tightened.

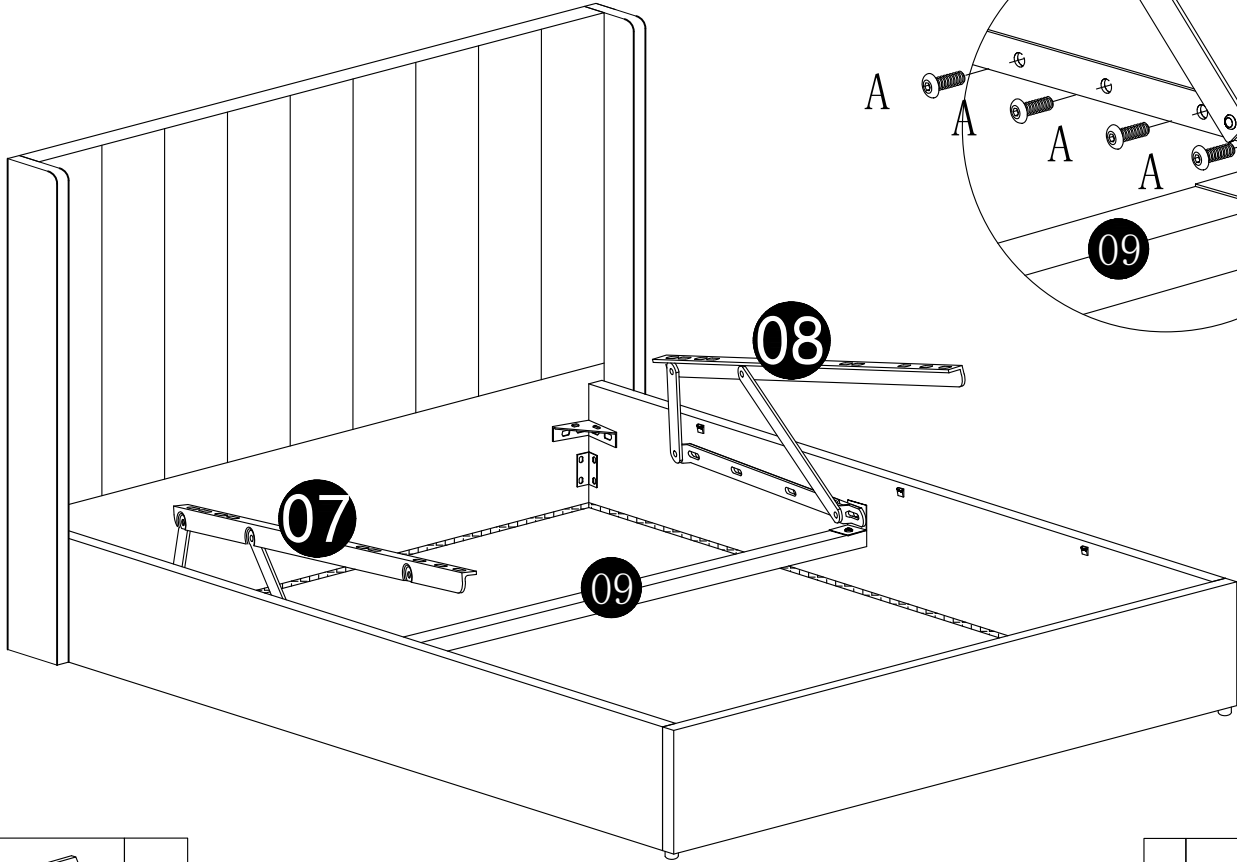

P

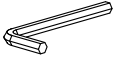

1

A



8\*20

8

14

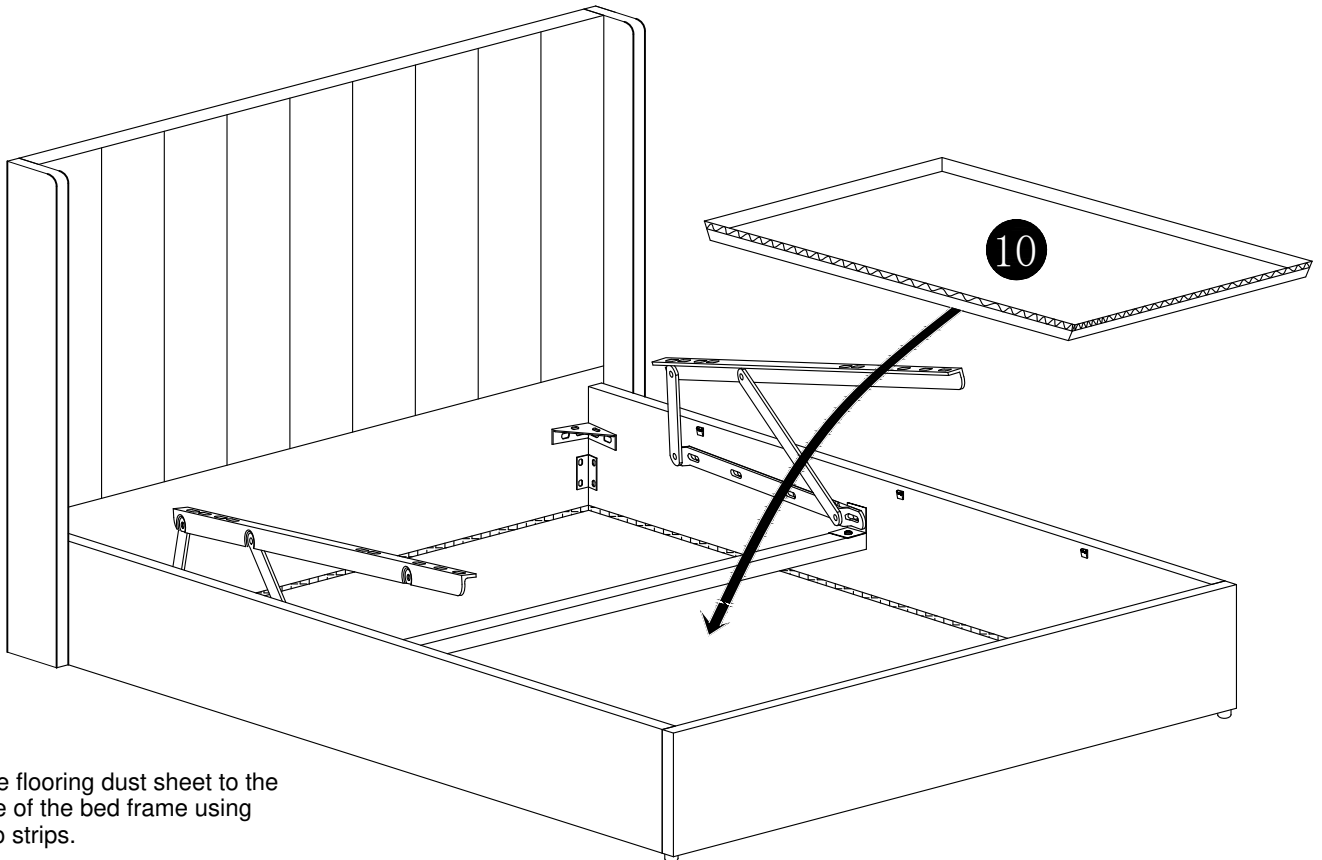



Attach the flooring dust sheet to the underside of the bed frame using the velcro strips.

15

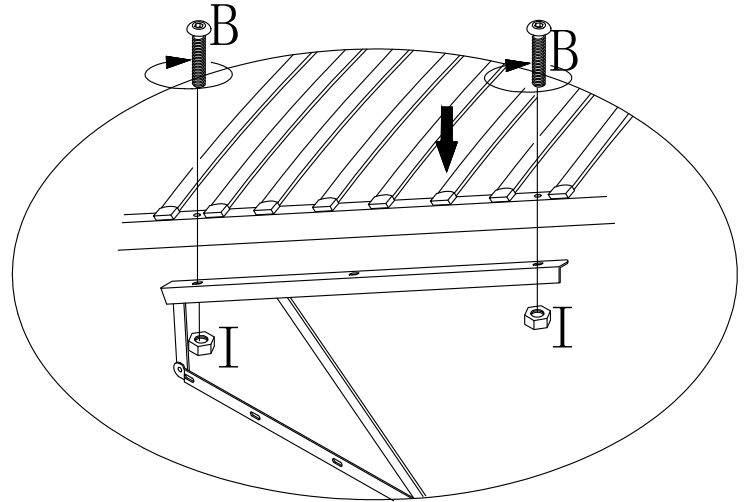
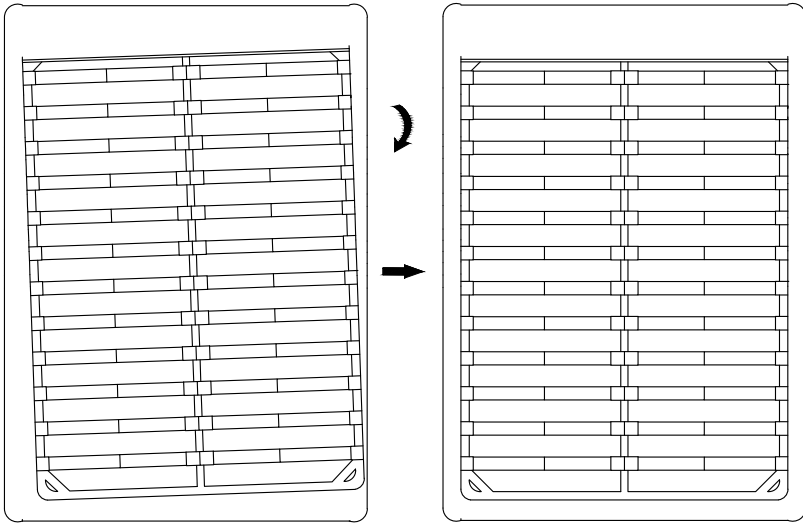
Recommended with 2 people, carefully lower the fully assembled ottoman frame onto the support arm mechanisms & fasten into place. Ensure that the frame is installed completely straight.

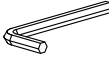
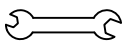

|   |   |   |   |   |   |
|---|---|---|---|---|---|
| P |  | 1 | 0 |  | 1 |
|---|---|---|---|---|---|

|   |   |   |   |   |   |
|---|---|---|---|---|---|
| I |  | 4 | B |  | 4 |
|---|---|---|---|---|---|

16

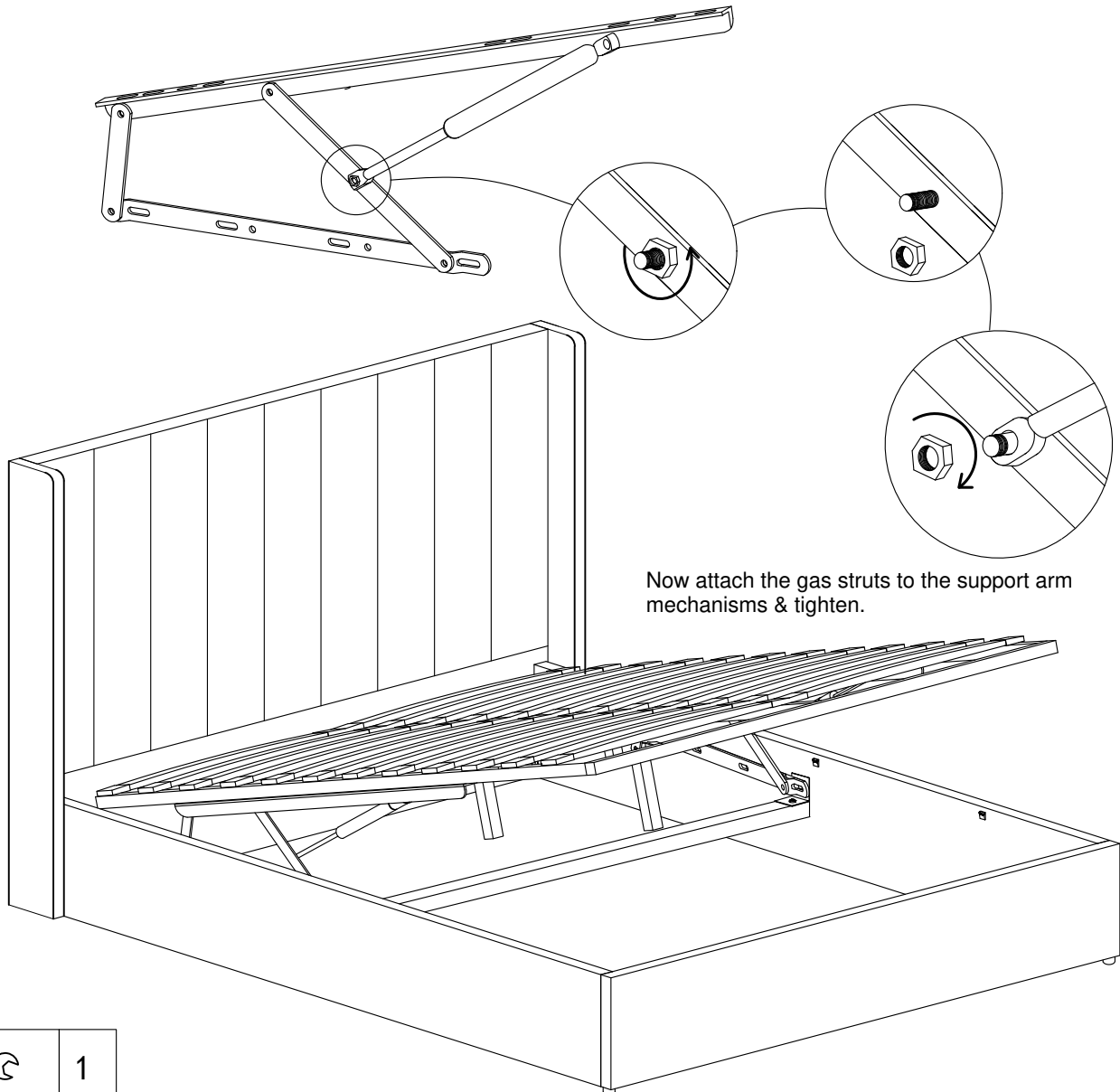

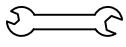
|   |   |   |
|---|---|---|
| 0 |  | 1 |
|---|---|---|

When pushing the ottoman frame down ensure that this is done with weight being pushed down with a central force & not by pushing down from one of the ends. This could damage the frame or mechanisms. It is advised that a mattress is placed on the ottoman frame & then the frame is lifted & closed two or three times to 'break' in the gas struts

before first use. With the weight of the mattress on the frame the ottoman will remain closed. Without any weight the frame is likely to remain in the 'open' position.

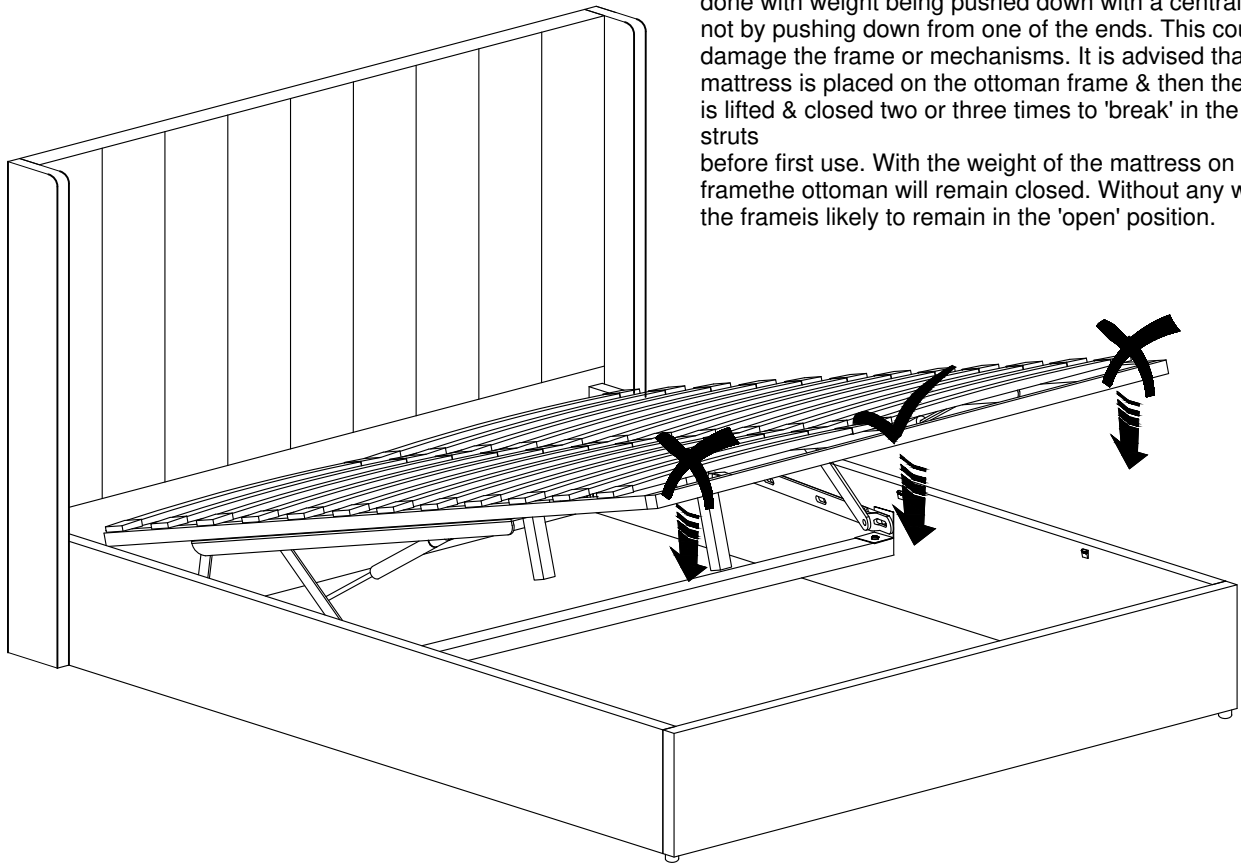

It is recommended that you double check to ensure that all fixings are tightened before use.