

Assembly instructions

WF530420 / WF530421

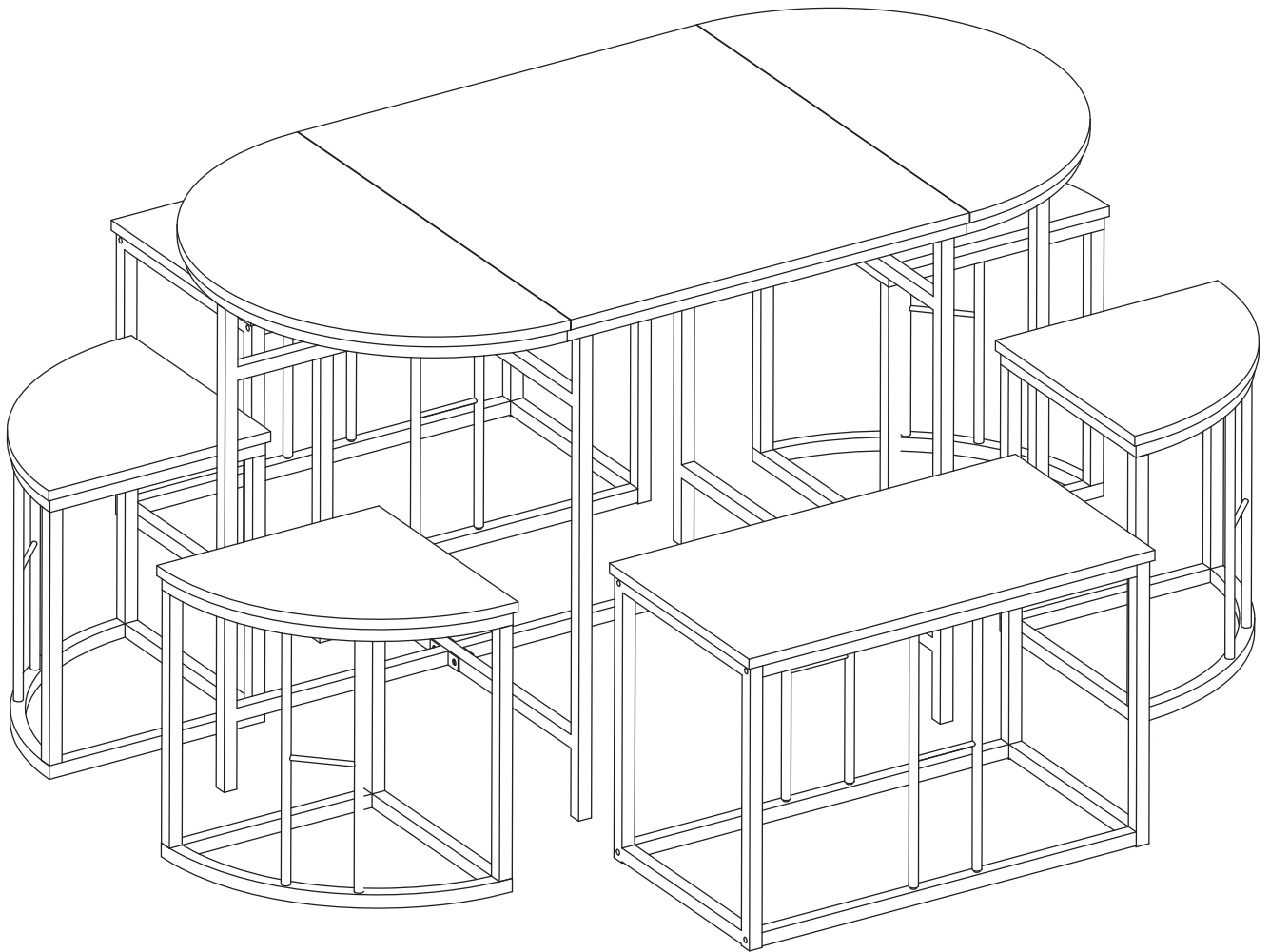

tool phillips head screwdriver



assembling time 1 hour 30 minutes



Our product will be delivered to you in 2 packages. The delivery times of these 2 packages may differ, please be patient and thank you for your understanding.

(A)

×6



Φ22*M6×25mm

(B)

×62



M6×40mm

(C)

×28



M6×30mm

(D)

×16



M6×40mm

(E)

×8



M6×15mm

(F)

×8



M6×17mm

(G)

×8



M6×12mm

(H)

×20



Φ13*M6×10mm

(I)

×2



4mm

(J)

×6



Φ8*30mm

Before installation, insert the screws into the holes and tighten them, but do not tighten them to 100%, 70% to 80% is sufficient. Finally, after all screws are installed, tighten all screws to 100%. If you encounter these issues, such as if the holes cannot be aligned or some parts cannot be installed, please check if the screws are used correctly and adjust the tightness of the screws.

Please note that this product contains multiple similar screws. Please strictly follow the instructions for installation and distinguish them! Otherwise, it will cause assembly failure! thanks.

Attention

- If you have any questions about this product, please contact your supplier in time.
- Make sure you have all the components and tools listed on the next page.
- Remove all fittings from the plastic bags and separate them into their groups.
- Keep children and animals away from the work area, small parts can suffocate if swallowed.
- Parts of the assembly are easier with 2 people.
- Make sure you have enough space to arrange the pieces before you begin.
- Do not stand on or put weight on the product as this may cause damage.
- Assemble the item as close as possible to its final position (in the same space).
- Mount the device on a soft, flat surface to avoid damaging the device or your floor (use the opened box of the device).

Care and Maintenance

- Clean only with a damp cloth and mild detergent, do not use bleach or abrasives.

If you have any questions about this product, please contact your supplier in time.

- Check from time to time whether the screws on the product are loose.

Note

- If necessary, the next page can be cut out and used as a reference throughout the assembly.
- Keep this page with these instructions for future reference.

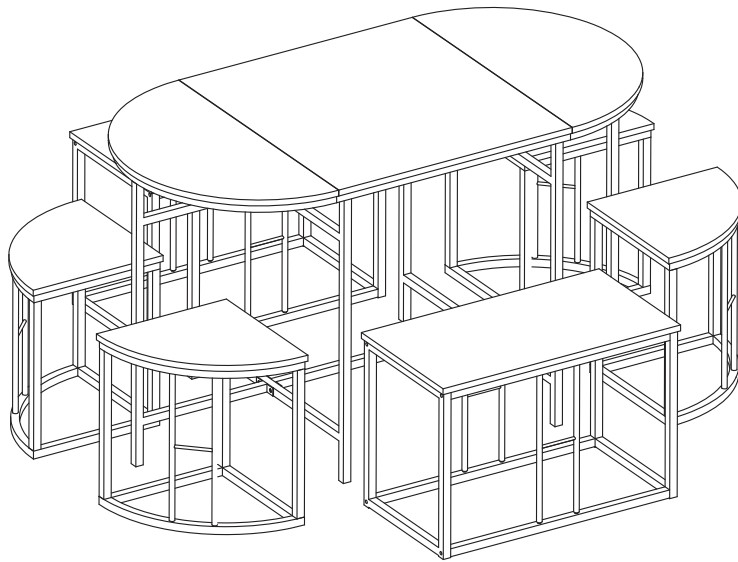

TOOLS:
does not contain tools.

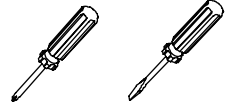

Packet 1/ Packet 2

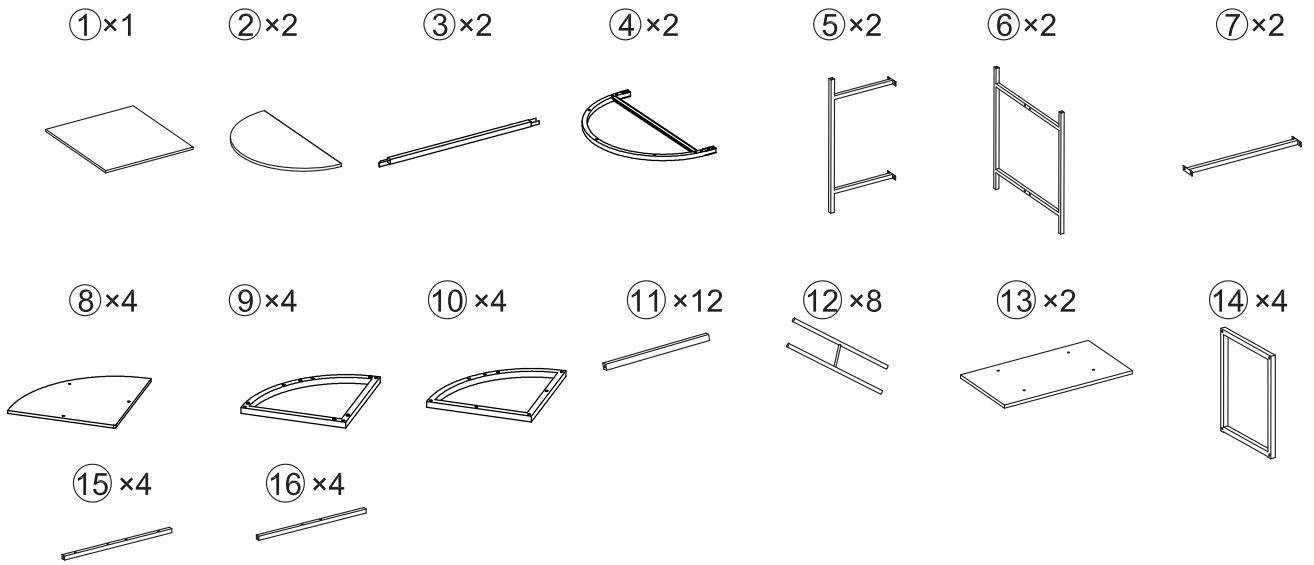

Packet 1/ Packet 2

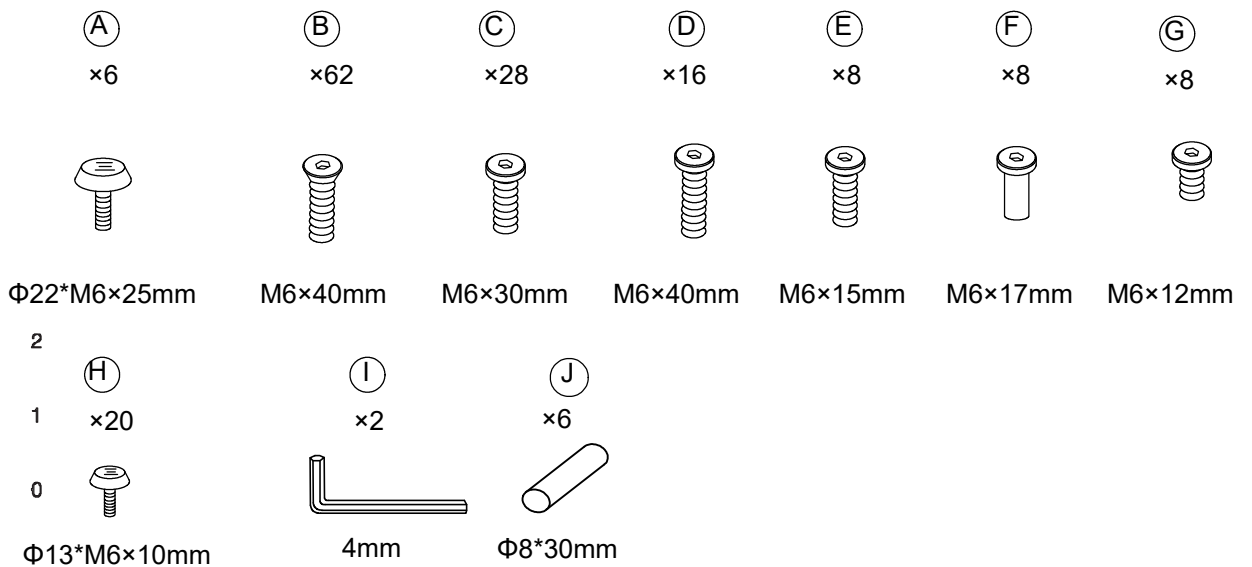

WF530420 BOX-1

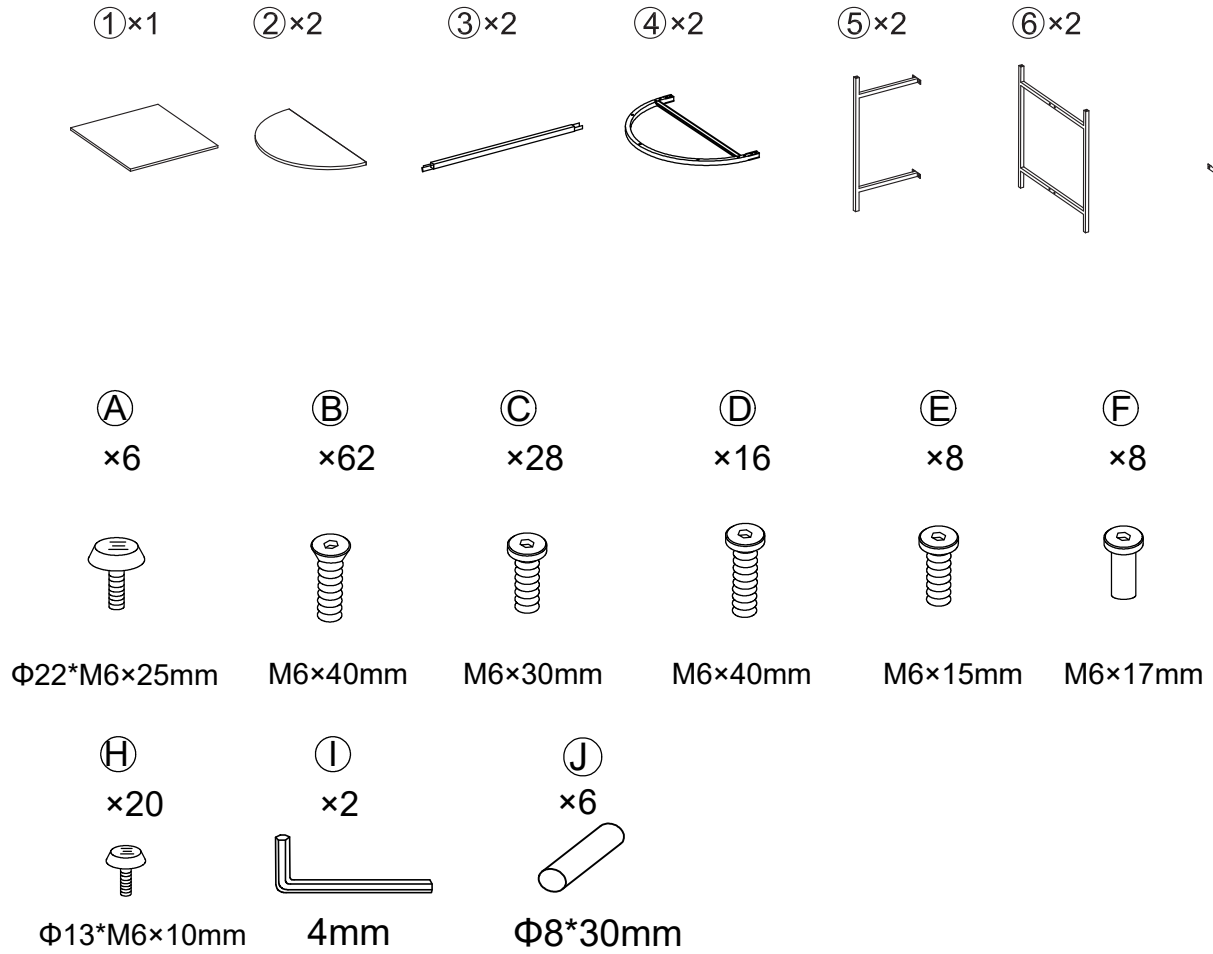

WF530421 BOX-2

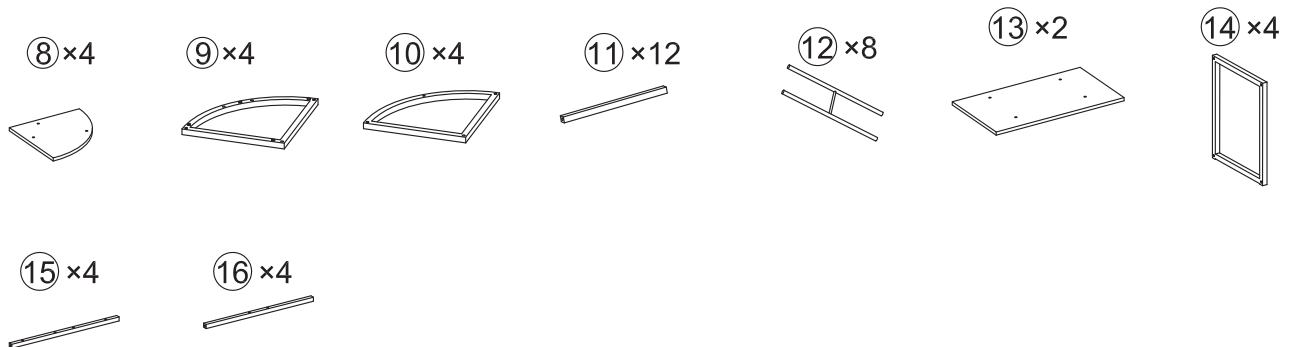

1.

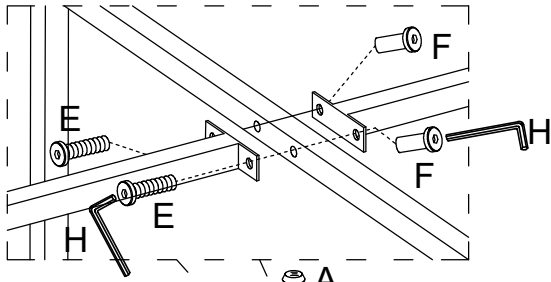

A×6
E×8
F×8

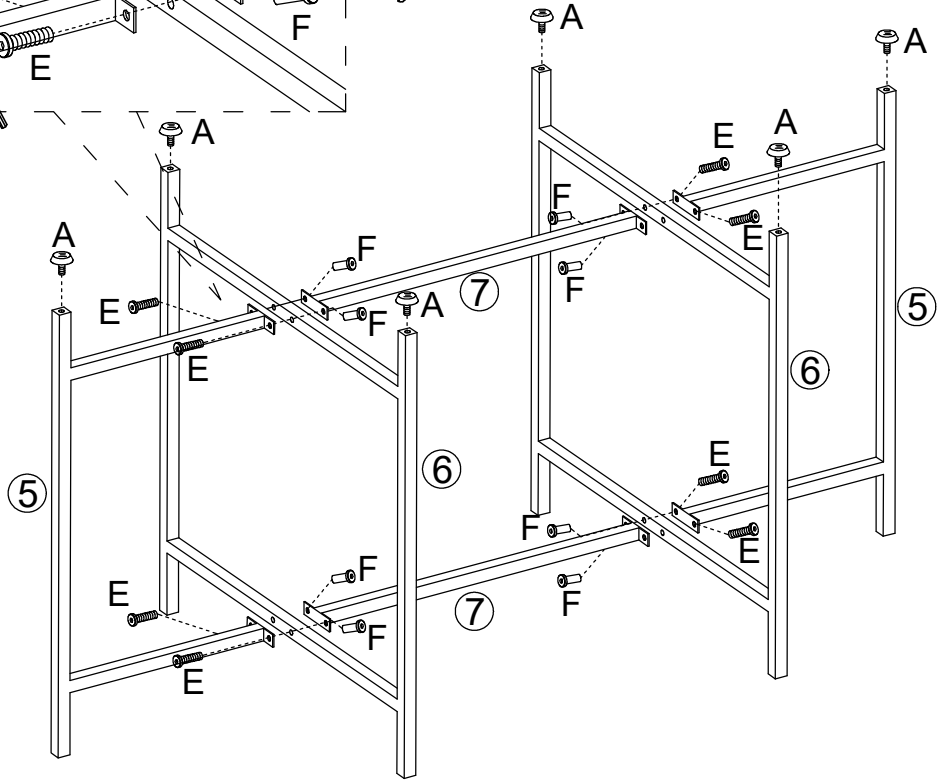

2.

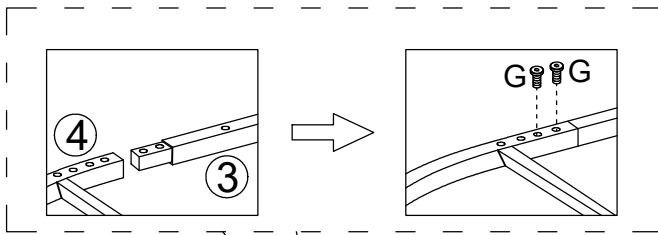

x4

G×8

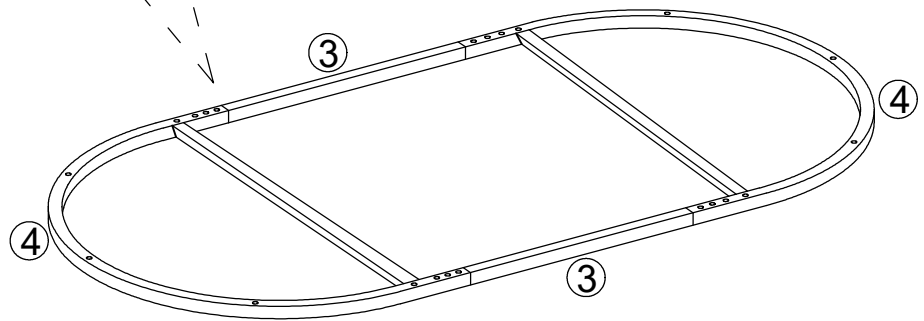

J×6

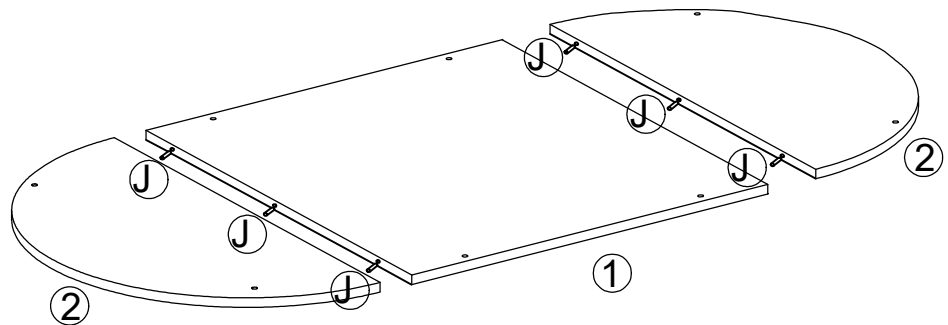

3.

B × 6

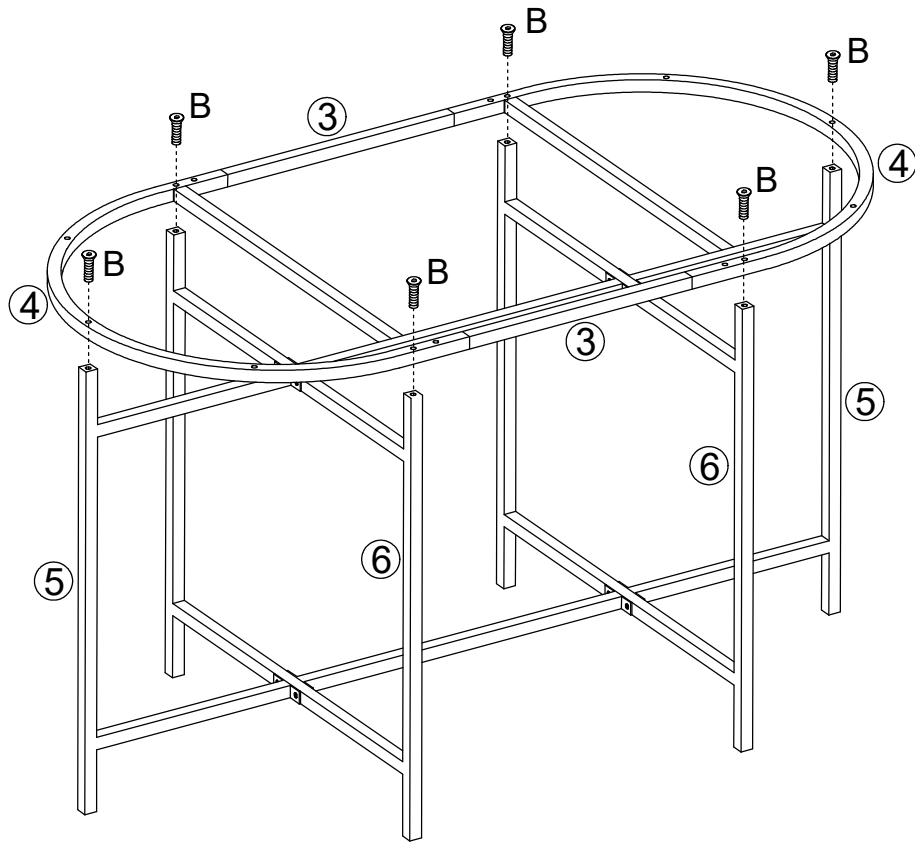

4.

C × 8

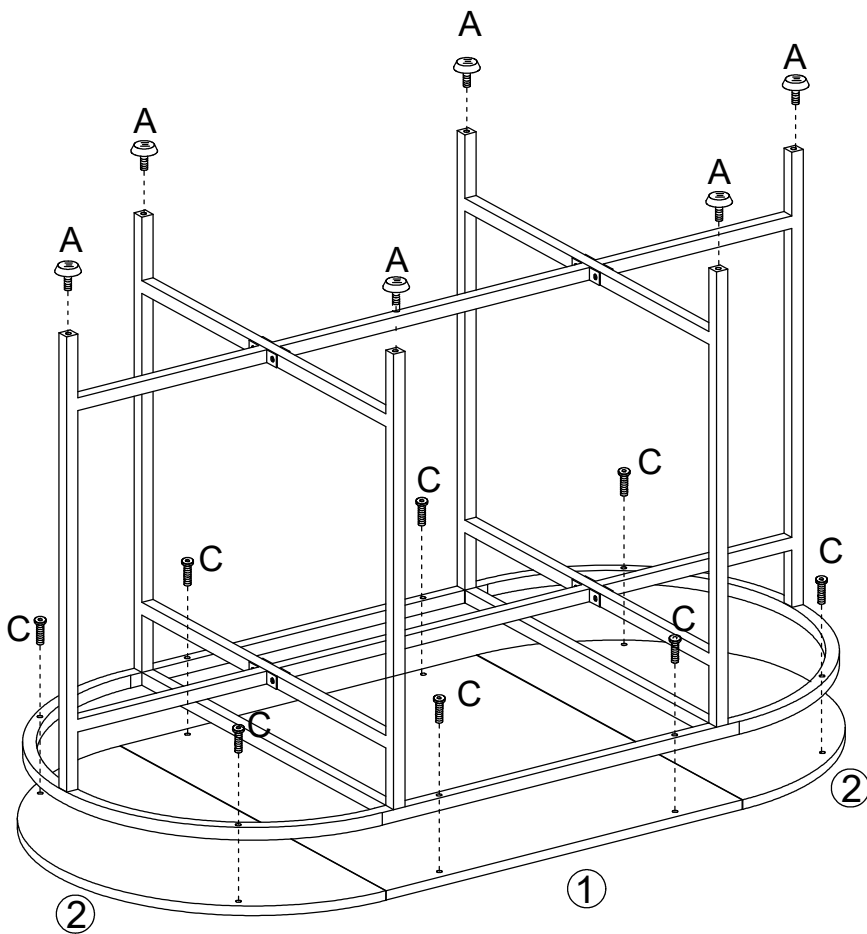

Please check if the tabletop is seamless,
and then uniformly tighten all screws on the table.

5.

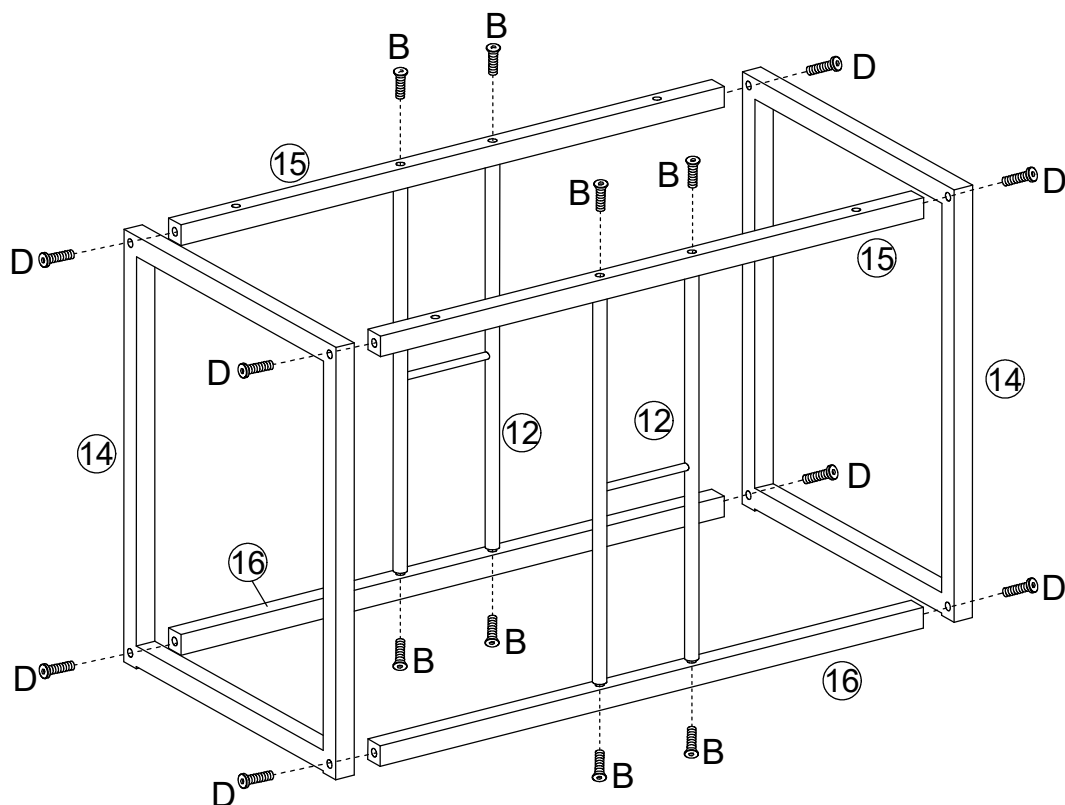

6.

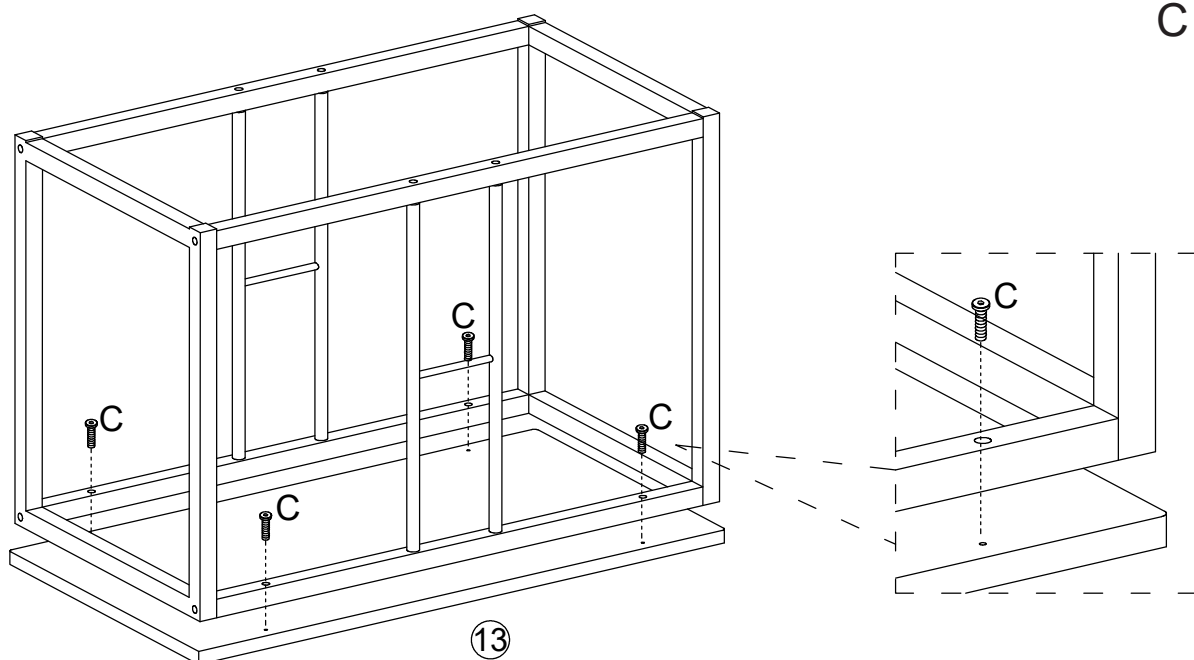

7.

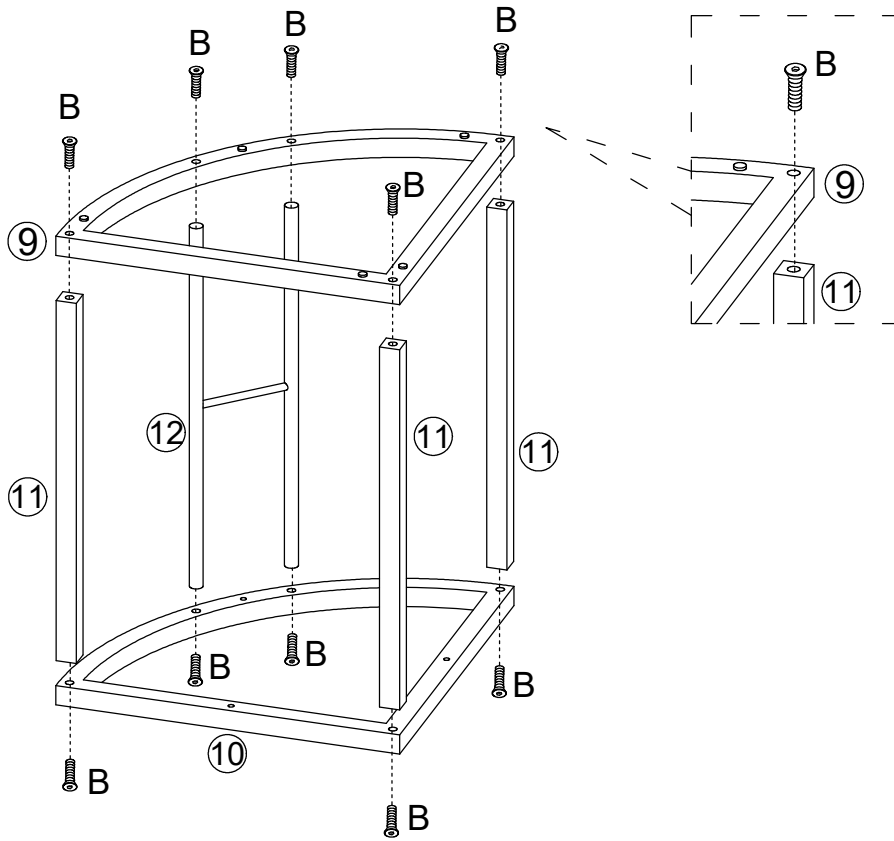

B×40

×4

8.

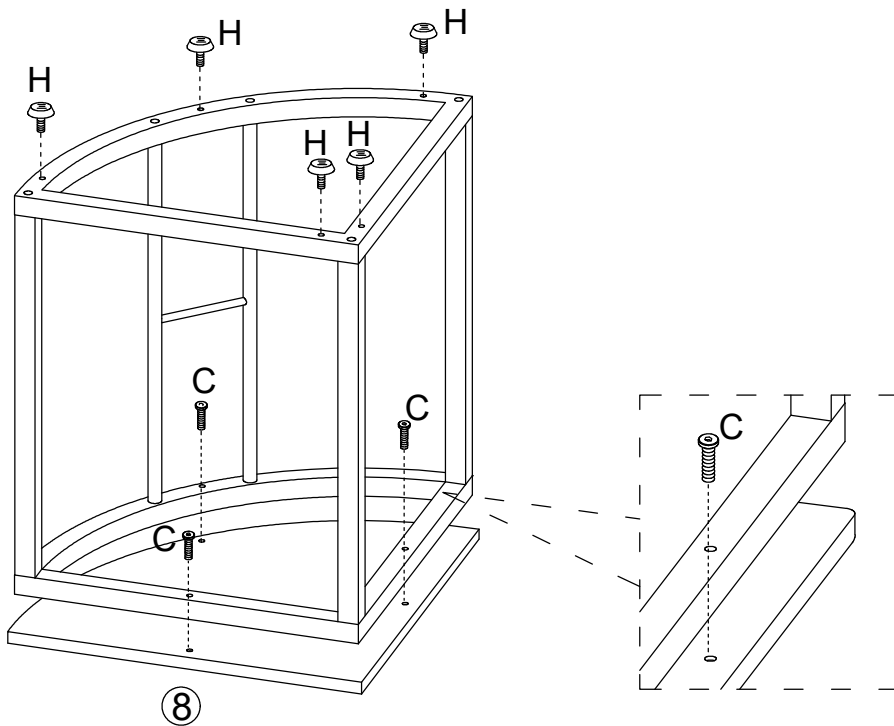

H×20

C×12

×4

9.

