

N605P286368

N605P286369

Product manual
Gebrauchsanweisung
Manuel du produit
Manual del producto
Manuale del prodotto

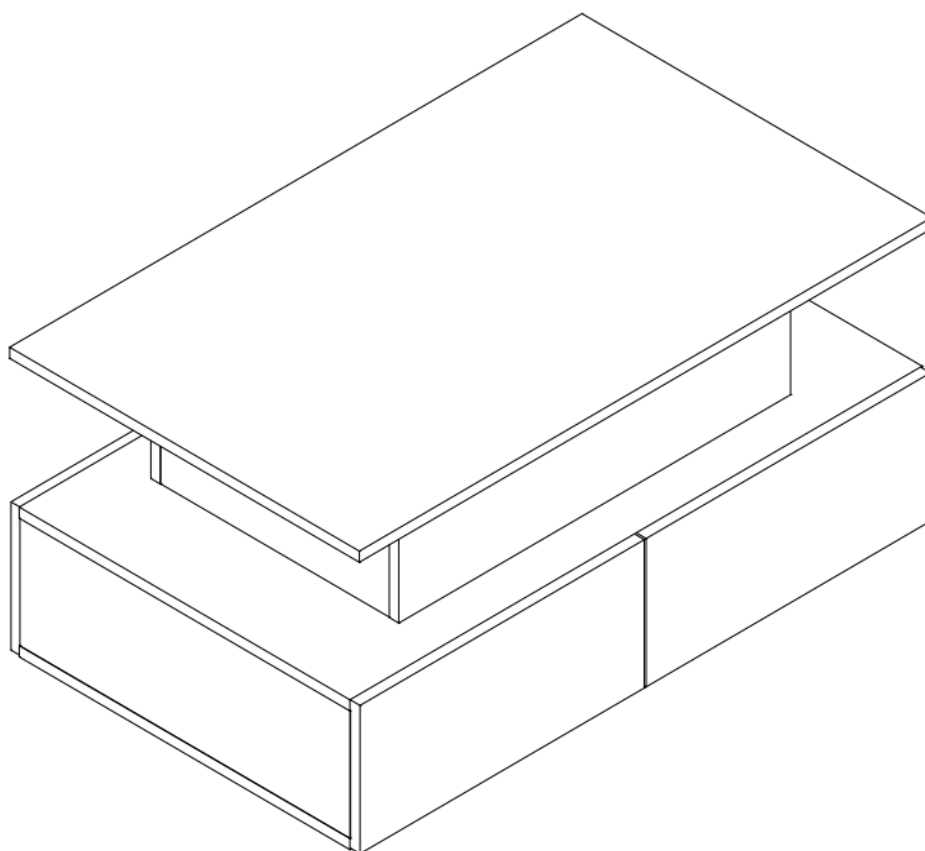

EN:Our product will be delivered to you in 2 packages.The delivery times of these 2 packages may differ, please be patient and thank you for your understanding







FR:Notre produit vous sera livré en 2 colis.Les délais de livraison de ces 2 colis peuvent différer,soyez patient et merci de votre compréhension.

DE:Unser Produkt wird Ihnen in 2 Paketen geliefert.Die Lieferzeiten dieser 2 Pakete können abweichen, bitte haben Sie etwas Geduld und vielen Dank für Ihr Verständnis

IT:I nostri prodotti vengono trasportati in due pacchetti. I tempi di consegna dei due pacchetti sono diversi: abbiate pazienza e vi ringrazio per la vostra comprensione .

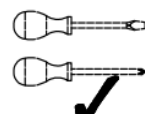
ES:Nuestro producto se entrega en dos paquetes. El tiempo de entrega de estos dos paquetes es diferente. Por favor, sea paciente.

Gracias por su comprensión.

 2PERS	 45 MIN	Tool Required Not Provided	
			



[DE]

Warnung: Lesen Sie die Anleitung vor dem Zusammenbau bitte vollständig durch. Überprüfen Sie, ob Sie alle auf den Seiten aufgeführten Komponenten und Werkzeuge haben.

Warnung: Legen Sie alle Teile auf eine ebene Fläche. Legen Sie eine weiche Decke oder Ähnliches darunter, um sie vor Kratzern oder Flecken zu schützen. Vermeiden Sie es, Komponenten über den Boden zu ziehen oder zu schieben.

Warnung: Überprüfen Sie regelmäßig alle Beschläge und Befestigungen, um sicherzustellen, dass sie sicher sind und um Unfälle zu vermeiden. Wenn Teile fehlen, kaputt, beschädigt oder abgenutzt sind, verwenden Sie das Produkt nicht weiter, bis es mit vom Hersteller autorisierten Teilen repariert wurde.

Warnung: Lassen Sie Kinder nicht auf die Möbel klettern, da dies zum Umkippen und zu schweren Verletzungen führen kann. Bauen Sie die Möbel außerhalb der Reichweite von Kindern zusammen.

Warnung: Stellen Sie die Möbel nicht in die Nähe von Feuerquellen oder heißen Gegenständen, um Brandgefahr zu vermeiden.

Warnung: Reinigen Sie die Möbel mit einem feuchten Tuch oder Alkohol. Verwenden Sie keine Reinigungsmittel mit ätzenden Chemikalien.

[EN]

Warning: Please read instructions fully before starting assembly. Check you have all the components and tools listed on pages.

Warning: Please place all parts on a flat surface. Place a soft blanket or similar underneath to protect against scratches or stains. Avoid dragging or sliding components across the floor.

Warning: Regularly check all fittings and fastenings to ensure they are secure and to prevent accidents. If any parts are missing, broken, damaged, or worn, discontinue use of the product until repairs have been made using factory authorized parts.

Warning: Do not allow children to climb on the furniture as this may result in tipping and serious personal injury. Assemble the furniture away from the reach of children.

Warning: Do not place furniture close to fire sources or high-temperature objects to avoid the risk of fire.

Warning: Clean furniture with a damp cloth or alcohol, avoid using cleaning agents containing corrosive chemicals.

[FR]

Avertissement : Veuillez lire entièrement les instructions avant de commencer l'assemblage. Vérifiez que vous disposez de tous les composants et outils répertoriés sur les pages.

Avertissement : Veuillez placer toutes les pièces sur une surface plane. Placez une couverture douce ou similaire en dessous pour les protéger des rayures ou des taches. Évitez de faire glisser les composants sur le sol.

Avertissement : Vérifiez régulièrement tous les raccords et fixations pour vous assurer qu'ils sont bien fixés et pour éviter les accidents. Si des pièces manquent, sont cassées, endommagées ou usées, cessez d'utiliser le produit jusqu'à ce que des réparations aient été effectuées à l'aide de pièces autorisées par l'usine.

Avertissement : Ne laissez pas les enfants grimper sur les meubles car cela pourrait entraîner un basculement et des blessures graves. Assemblez les meubles hors de portée des enfants.

Avertissement : Ne placez pas les meubles à proximité de sources de feu ou d'objets à haute température pour éviter tout risque d'incendie.

Avertissement : Nettoyez les meubles avec un chiffon humide ou de l'alcool, évitez d'utiliser des produits de nettoyage contenant des produits chimiques corrosifs.



[IT]

Attenzione: leggere attentamente le istruzioni prima di iniziare il montaggio. Verificare di avere tutti i componenti e gli strumenti elencati nelle pagine.

Attenzione: posizionare tutte le parti su una superficie piana. Posizionare una coperta morbida o simile sotto per proteggere da graffi o macchie. Evitare di trascinare o far scivolare i componenti sul pavimento.

Attenzione: controllare regolarmente tutti i raccordi e i dispositivi di fissaggio per assicurarsi che siano sicuri e per prevenire incidenti. Se alcune parti sono mancanti, rotte, danneggiate o usurate, interrompere l'uso del prodotto fino a quando non siano state eseguite le riparazioni utilizzando parti autorizzate dalla fabbrica.

Attenzione: non consentire ai bambini di arrampicarsi sui mobili poiché ciò potrebbe causare ribaltamenti e gravi lesioni personali. Montare i mobili lontano dalla portata dei bambini.

Attenzione: non posizionare i mobili vicino a fonti di fuoco o oggetti ad alta temperatura per evitare il rischio di incendio.

Attenzione: pulire i mobili con un panno umido o alcol, evitare di utilizzare detergenti contenenti sostanze chimiche corrosive.

[ES]

Advertencia: Lea las instrucciones completamente antes de comenzar el montaje. Compruebe que tiene todos los componentes y herramientas que se enumeran en las páginas.

Advertencia: Coloque todas las piezas sobre una superficie plana. Coloque una manta suave o algo similar debajo para protegerlas de rayones o manchas. Evite arrastrar o deslizar los componentes por el piso.

Advertencia: Verifique regularmente todos los accesorios y fijaciones para asegurarse de que estén seguros y evitar accidentes. Si falta alguna pieza, está rota, dañada o desgastada, deje de usar el producto hasta que se hayan realizado las reparaciones con piezas autorizadas de fábrica.

Advertencia: No permita que los niños se suban a los muebles, ya que esto puede provocar que se vuelquen y lesiones personales graves. Monte los muebles fuera del alcance de los niños.

Advertencia: No coloque los muebles cerca de fuentes de fuego u objetos de alta temperatura para evitar el riesgo de incendio.

Advertencia: Limpie los muebles con un paño húmedo o alcohol, evite usar agentes de limpieza que contengan químicos corrosivos.

Importeur	Decobus Handel GmbH		
Adresse	Innungsstraße 9, 21244 Buchholz, Deutschland		
URL	https://www.decobusgroup.de		
Hersteller	SHANDONG YIJUMUZHAI SMART HOMECO.,LTD		
Adresse	1666MEASTOFJINGUANG STREETBRIDGE,LUOCHENG TOWN, SHOUGUANGCITY,WEIFANG CITY,SHANDONG PROVINCE		
Email/URL	http://www.yinjumuzhai.com		
<table border="1"><tr><td>EC</td><td>REP</td></tr></table>	EC	REP	Decobus Handel GmbH Innungsstraße 9, 21244 Buchholz, Deutschland https://www.decobusgroup.de
EC	REP		

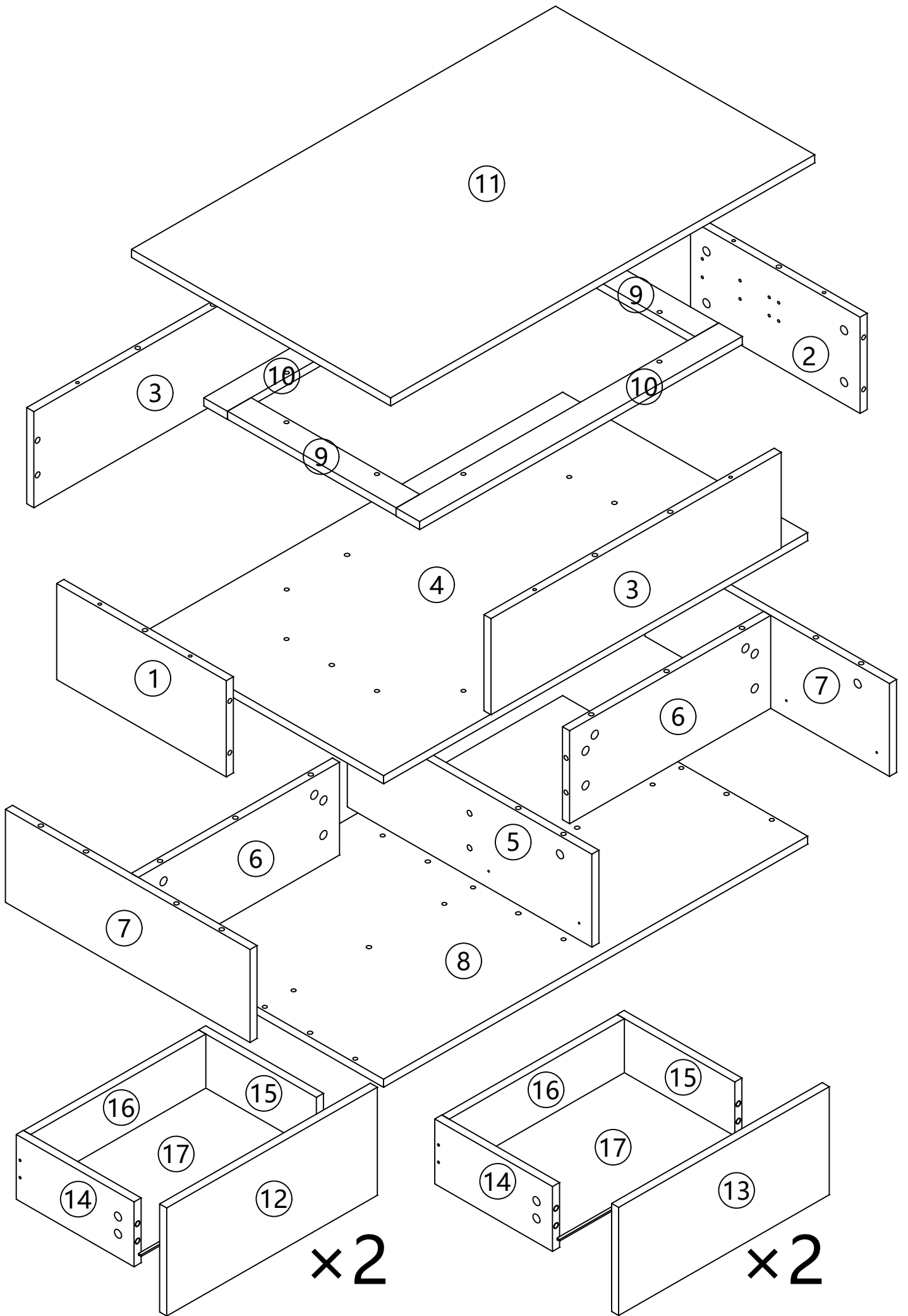

N605P286368

1

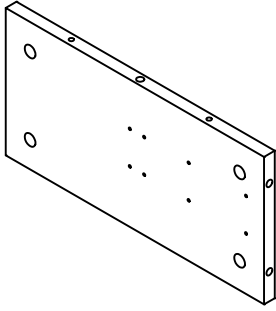

1PC

2

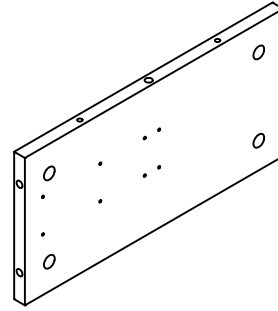

1PC

3

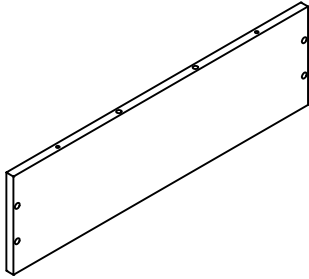

2PCS

4

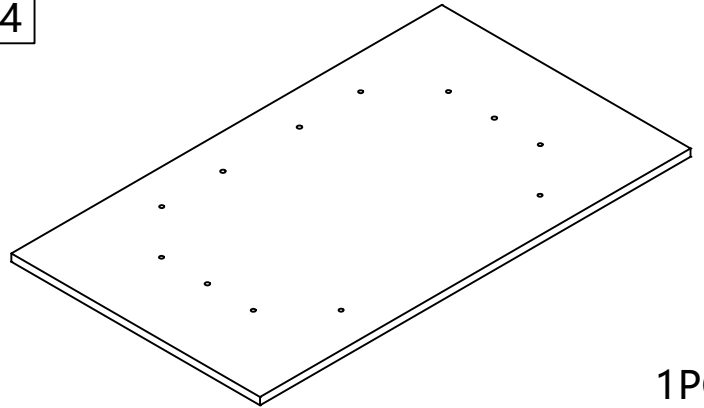

1PC

8

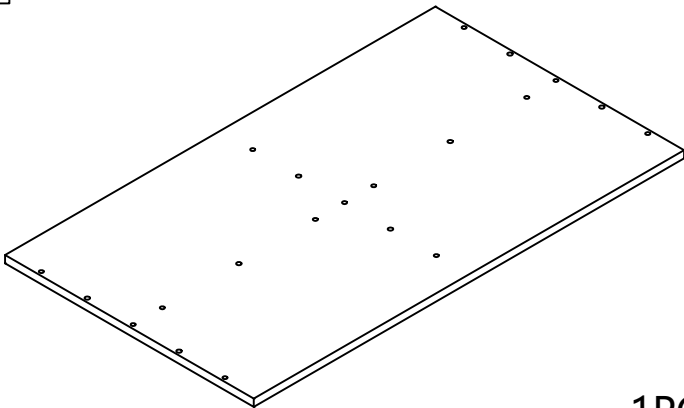

1PC

9

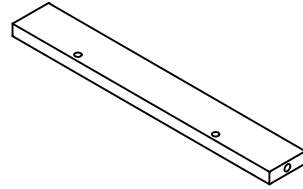

2PCS

10

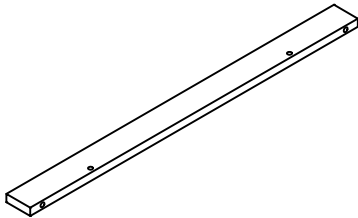

2PCS

14

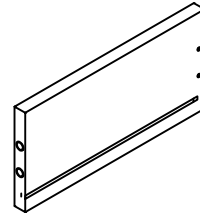

4PCS

17

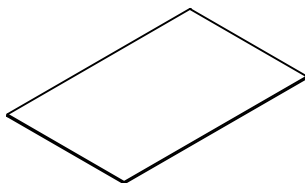

4PCS

N605P286369

5

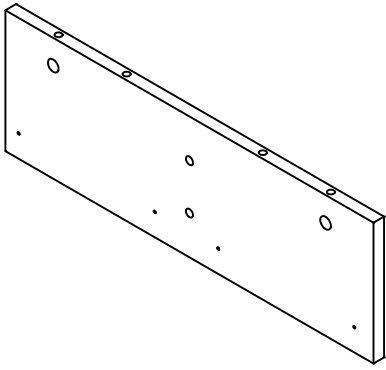

1PC

6

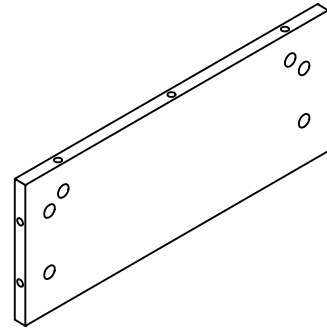

2PCS

7

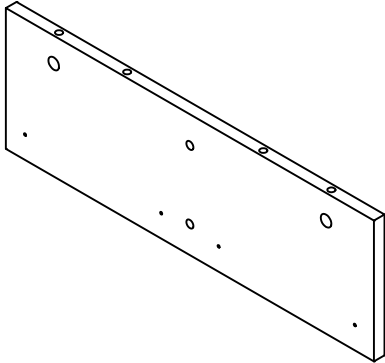

2PCS

11

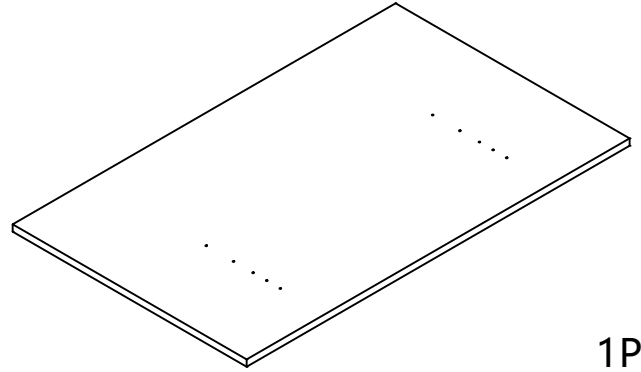

1PC

12

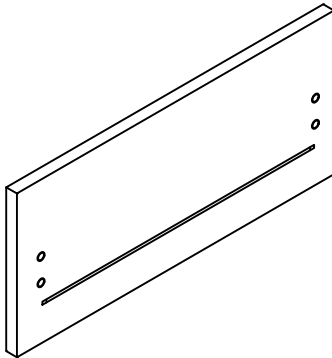

2PCS

13

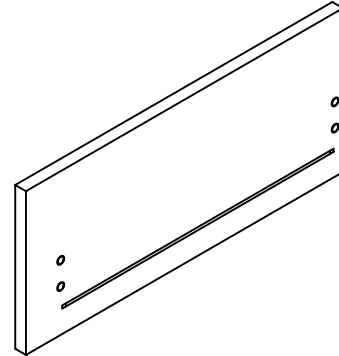

2PCS

15

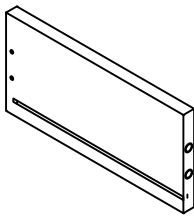

4PCS

16

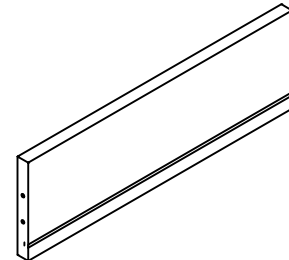

4PCS

N605P286369

A

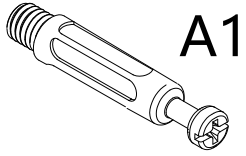

A1

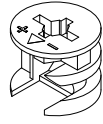

A2

42SETS

B

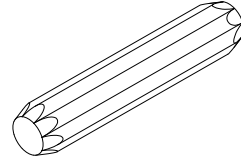

8x40mm

32PCS

C

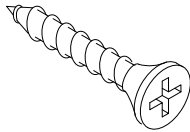

3.5x14mm

66PCS

D

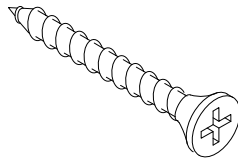

3.5x35mm

16PCS

E

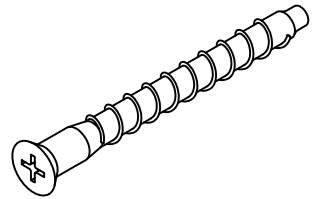

7x50mm

29PCS

F

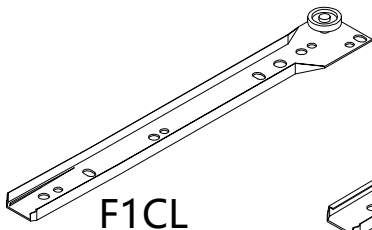

F1CL

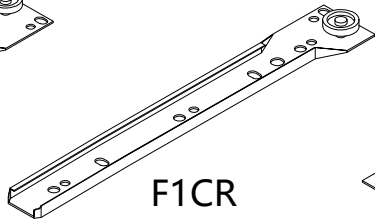

F1CR

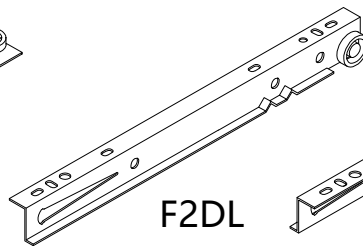

F2DL

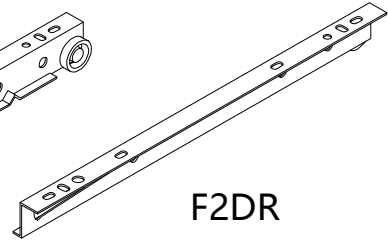

F2DR

250mm
4SETS

G

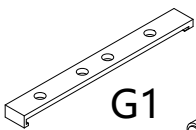

G1

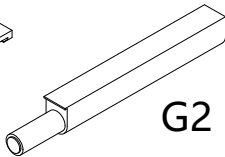

G2

4PCS

H

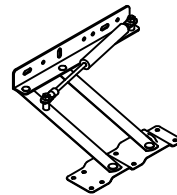
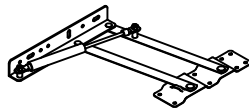

1SET

J

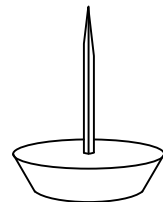

6PCS

K

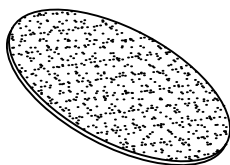

16PCS

L

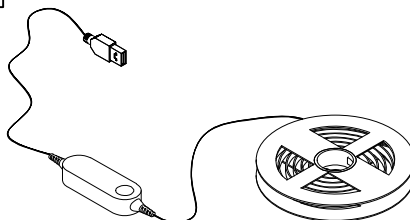

1PC

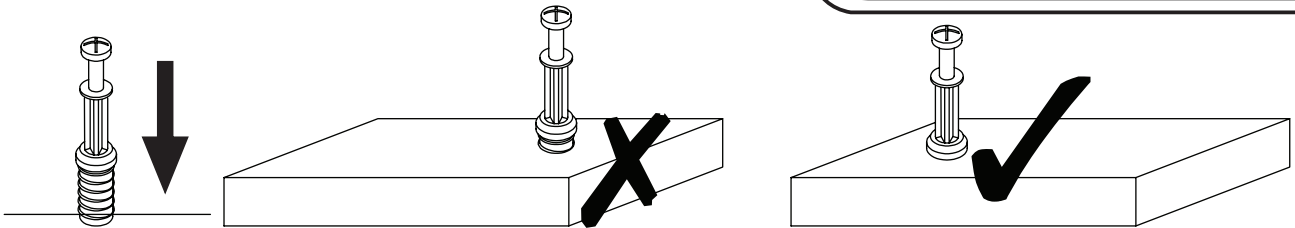

EN_QUICKFIT: Tighten quickfit until shoulder is flush with panel. Do not overtighten or undertighten.

FR_RACCORD RAPIDE: Faites serrer le raccord rapide jusqu'à ce que l'épaulement soit parfaitement encastré dans le panneau. Il ne faut ni trop serrer ni insuffisamment serrer.

ES_QUICKFIT: Apriete quickfit hasta que el hombro se descargue con el panel. NO lo sobreapriete ni lo apriete poco.

DE_QUICKFIT: Ziehen Sie den Quickfit fest, bis die Schulter mit der Platte bündig ist. Bitte nicht zu fest oder zu schwach anziehen.

IT_MONTAGGIO RAPIDO: Stringere il montaggio rapido fino a quando la spalla è a filo con il pannello, non stringere troppo o troppo poco.

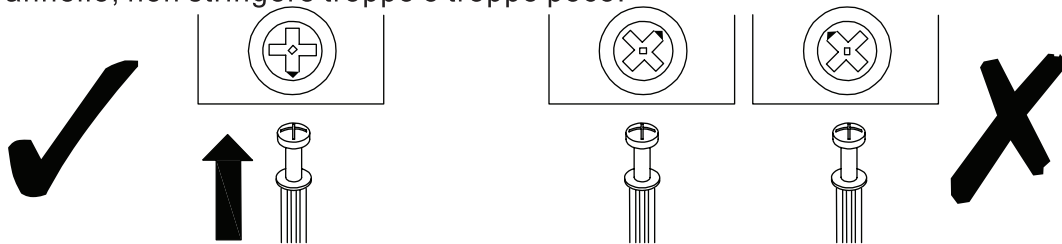

EN_CAM LOCK: When fitting cam lock, ensure starting position is correct before you insert connecting quickfit.

FR_SERRURE BATTEUSE: Avant d'insérer la serrure batteuse, veillez à la bonne orientation avant d'insérer le raccord rapide.

ES_CIERRE DE LA CÁMARA: Cuando instale el cierre de la cámara, asegúrese de que la posición de inicio es correcta antes de que inserte el quickfit conector.

DE_CAM-LOCK: Achten Sie bei der Montage des Cam-Locks auf die richtige Ausgangsposition, bevor Sie den Quickfit einsetzen.

IT_BLOCCAGGIO A CAMMA: Quando si monta il bloccaggio a camma, assicurarsi che la posizione iniziale sia corretta prima di inserire il montaggio rapido di collegamento.

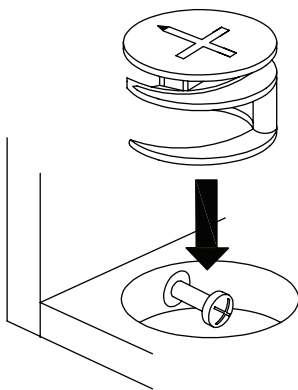

EN_Quickfit head should be in the centre of the cam lock when the two panels are joined.

Cam lock should be inserted before quickfit.

FR_Lorsque les deux panneaux sont assemblés, la tête du raccord rapide doit reposer au centre de la serrure batteuse. Il faut insérer la serrure batteuse avant le raccord rapide.

ES_El cabezal del quickfit debe estar en el centro del cierre de la cámara cuando se unan los dos paneles.

Se debe insertar el cierre de la cámara antes que el quickfit.

DE_Der Quickfit-Kopf sollte sich in der Mitte des Cam-Locks befinden, wenn die beiden Platten zusammengefügt sind. Der Cam-Lock sollte vor dem Quickfit eingesetzt werden.

IT_La testa del montaggio rapido deve trovarsi al centro del bloccaggio a camma quando i due pannelli sono uniti.

Il Bloccaggio a Camma deve essere inserito prima del montaggio rapido.

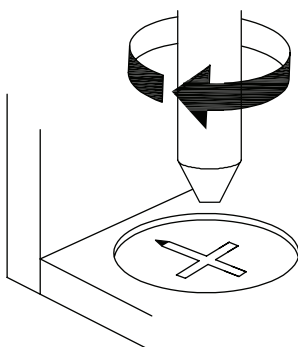

EN_Turn cam lock clockwise to tighten.

FR_Faites tourner la serrure batteuse dans le sens des aiguilles d'une montre pour la resserrer.

ES_Gire el cierre de la cámara en sentido horario para apretarlo.

DE_Drehen Sie den Cam-Lock im Uhrzeigersinn, um ihn festzuziehen.

IT_Ruotare il bloccaggio a camma in senso orario per stringere.

1

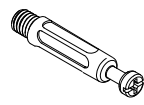

A1 x 8

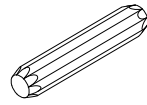

B x 12

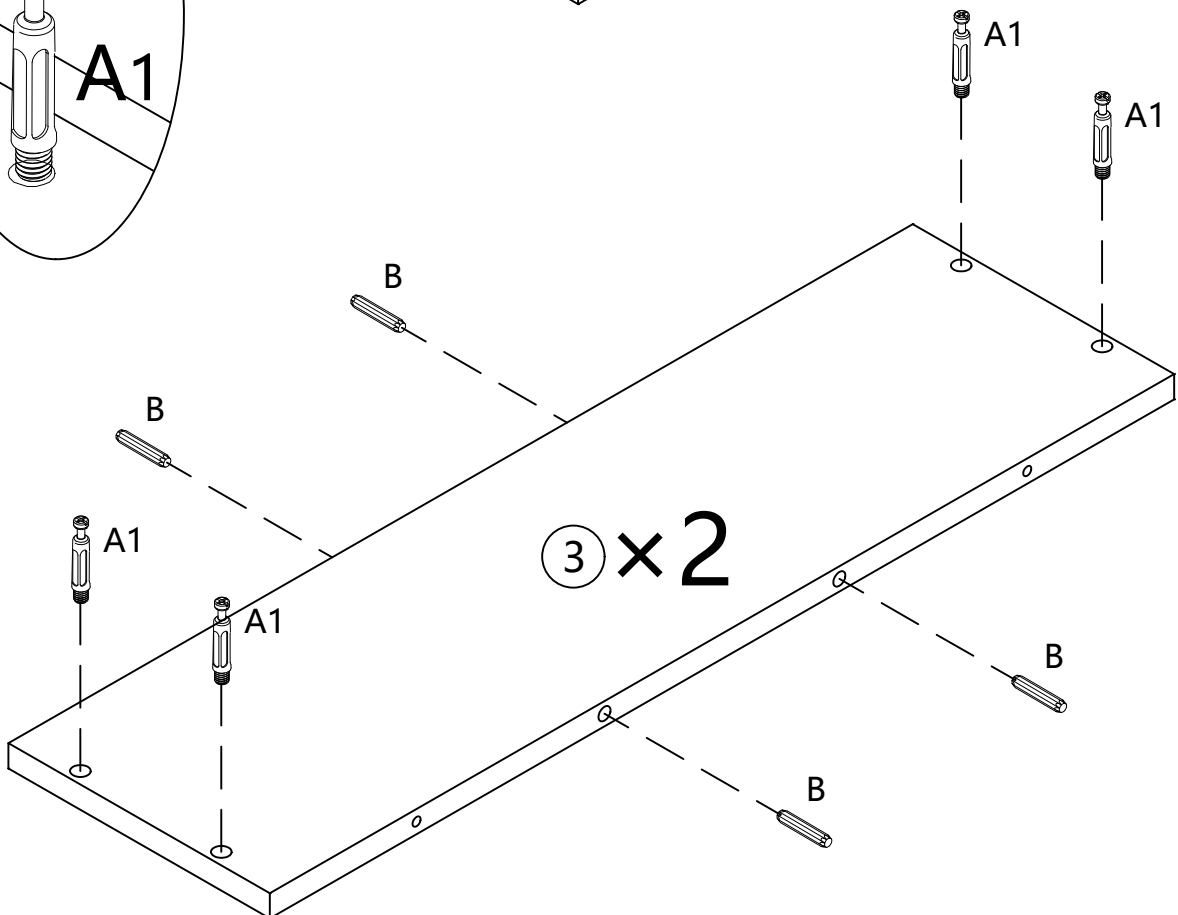
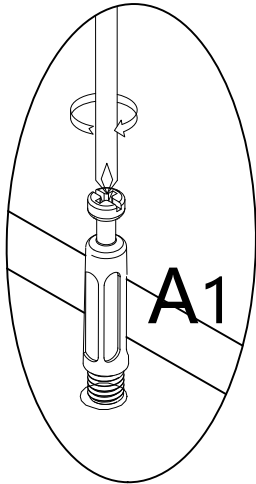
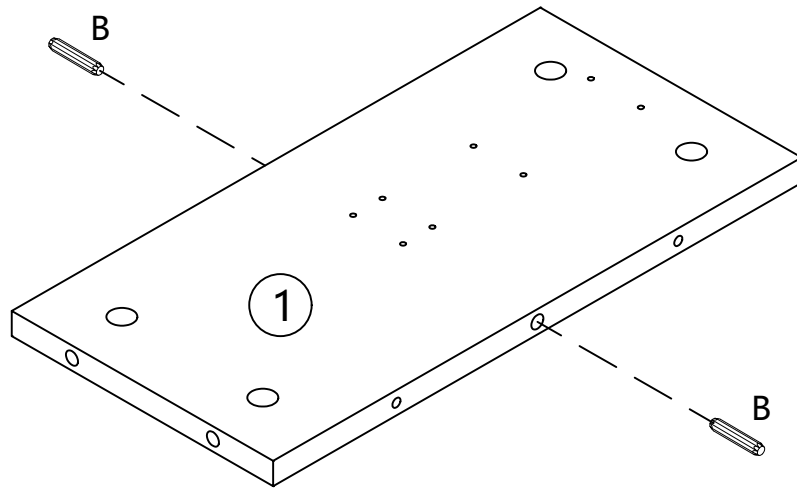
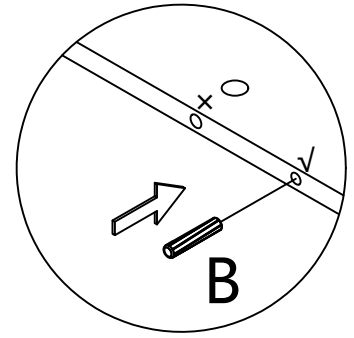
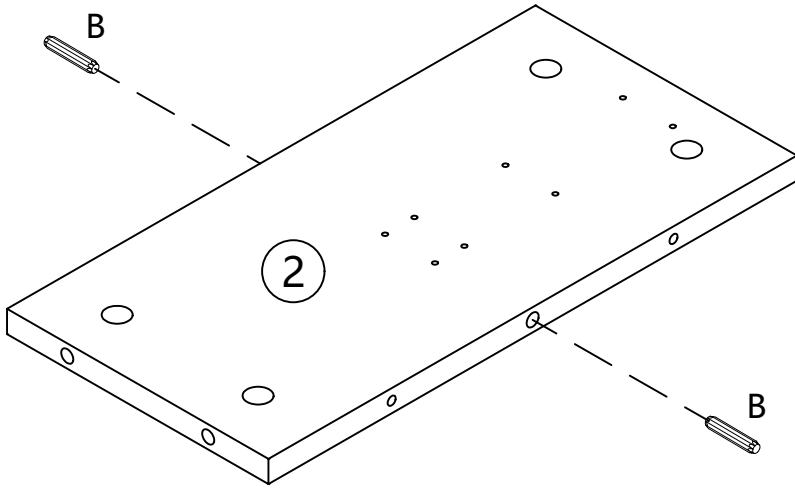

3 x 2

2

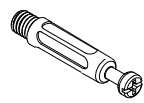

A1 x 10

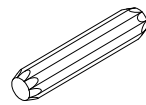

B x 4



C x 8

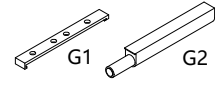

G x 4

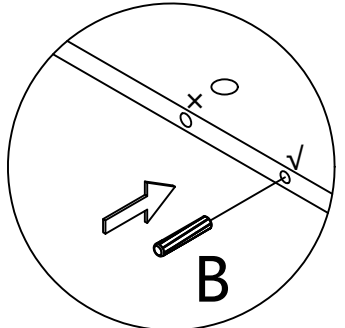
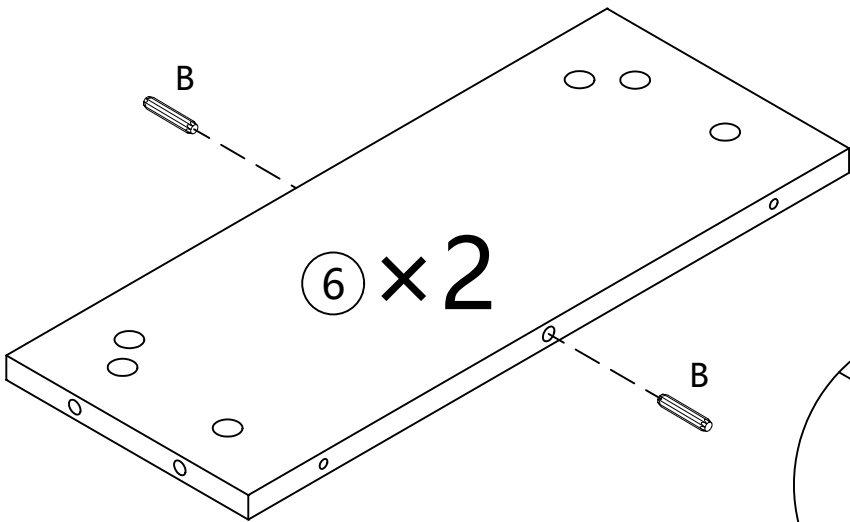
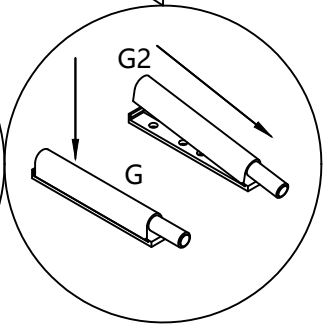
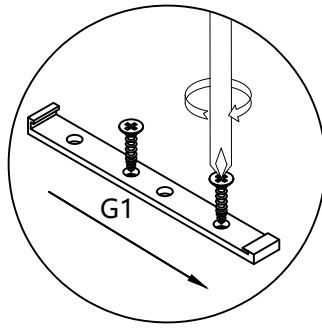
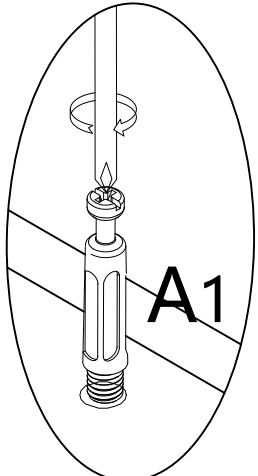
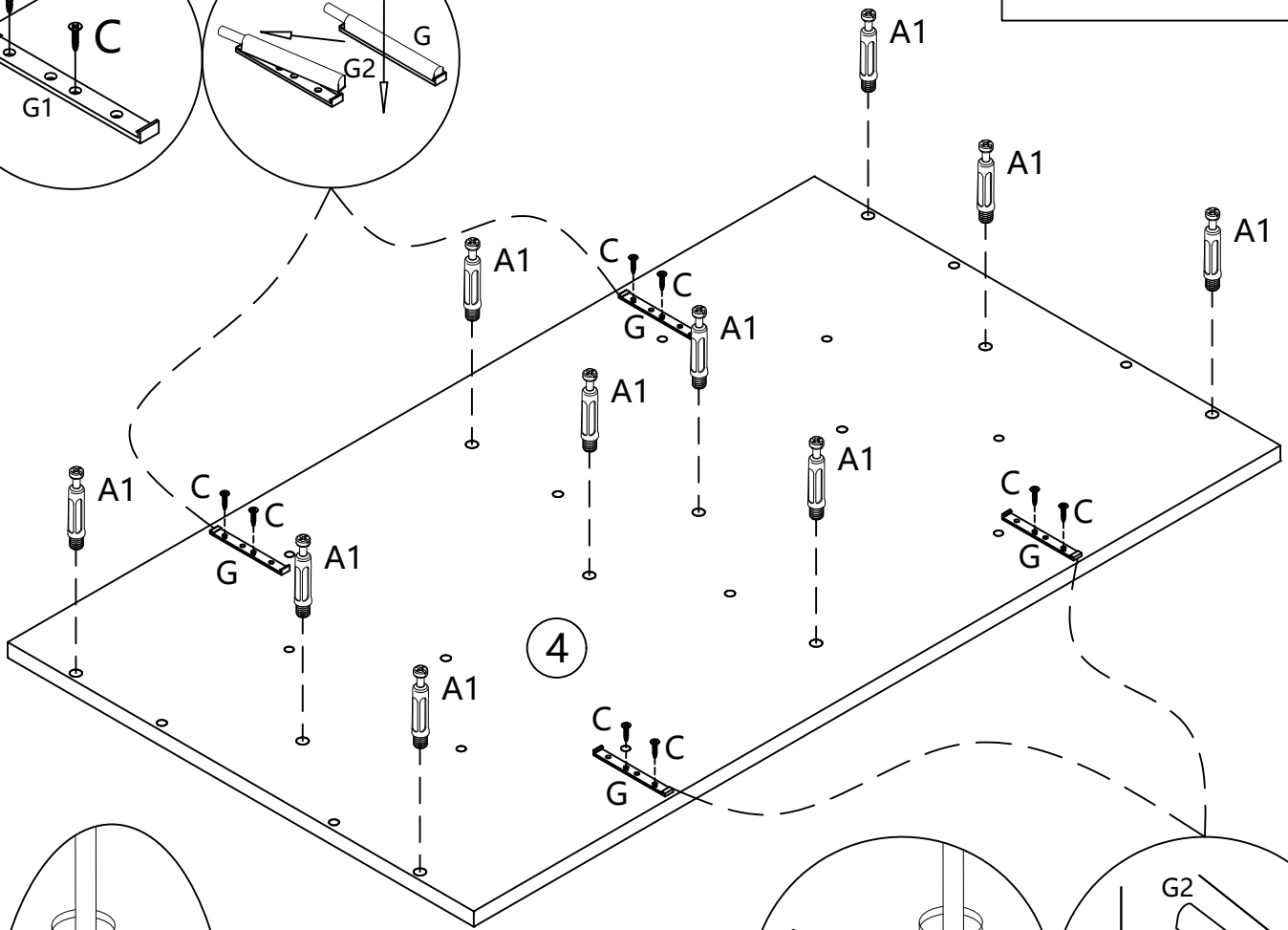
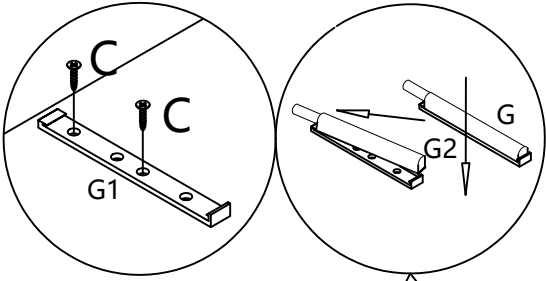

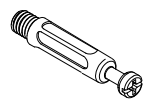
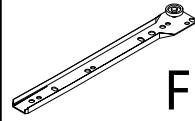
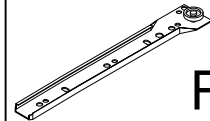
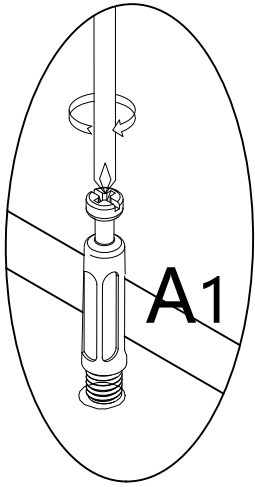
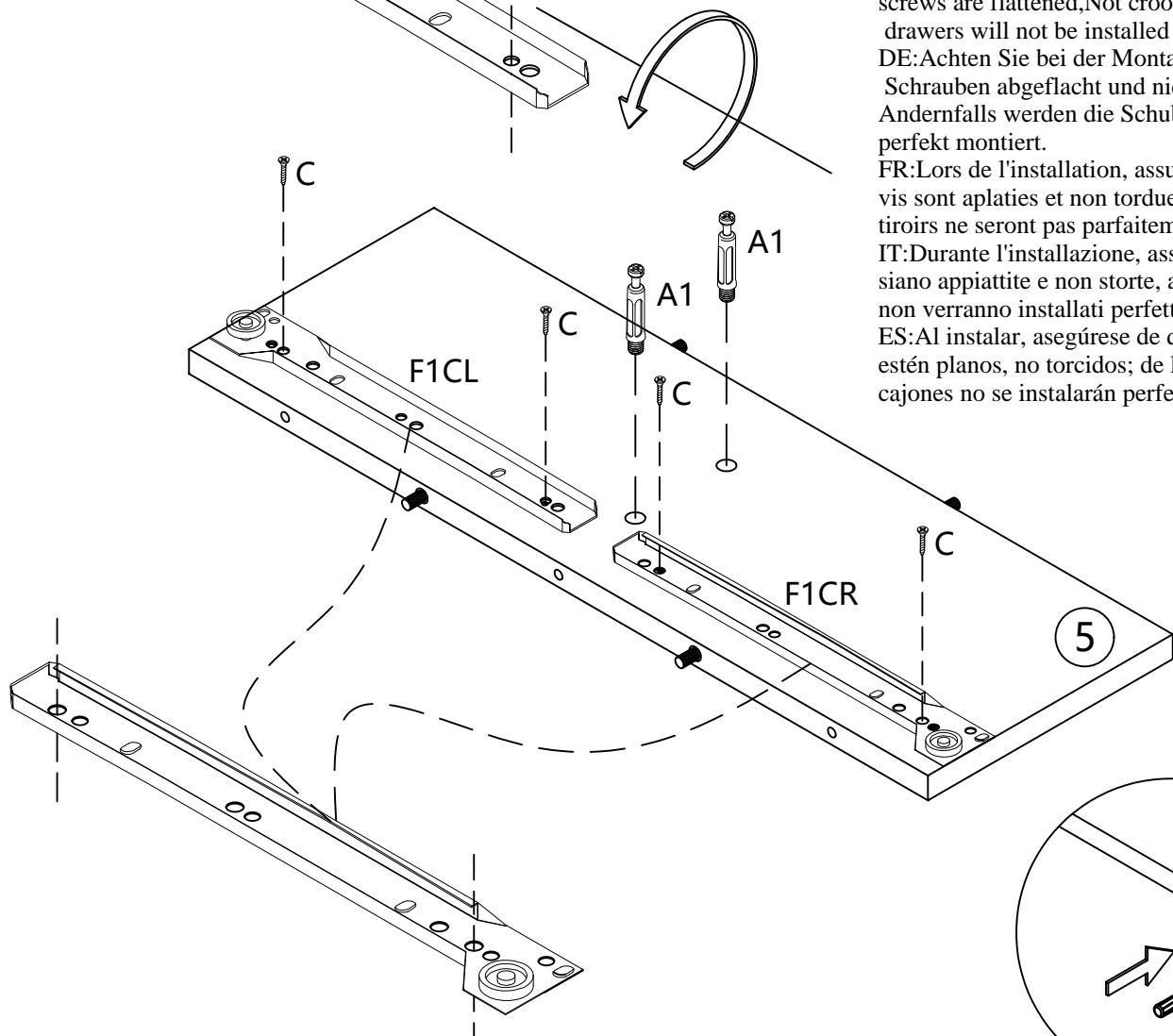
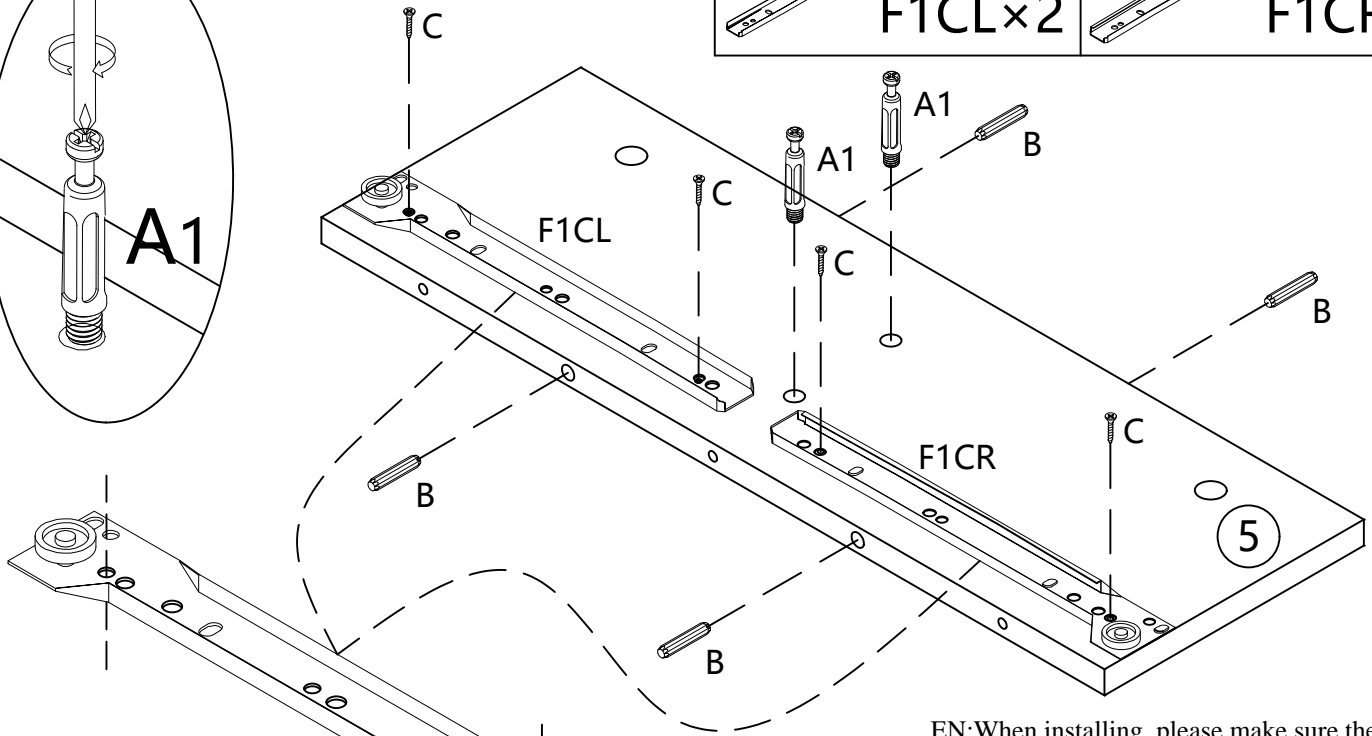
3**A1×4****B×4****C×8****F1CL×2****F1CR×2****A1**

EN:When installing, please make sure the screws are flattened,Not crooked;Otherwise the drawers will not be installed perfectly.
 DE:Achten Sie bei der Montage darauf, dass die Schrauben abgeflacht und nicht schief sind. Andernfalls werden die Schubladen nicht perfekt montiert.
 FR:Lors de l'installation, assurez-vous que les vis sont aplaties et non tordues ; sinon, les tiroirs ne seront pas parfaitement installés.
 IT:Durante l'installazione, assicurarsi che le viti siano appiattite e non storte, altrimenti i cassetti non verranno installati perfettamente.
 ES:Al instalar, asegúrese de que los tornillos estén planos, no torcidos; de lo contrario, los cajones no se instalarán perfectamente.

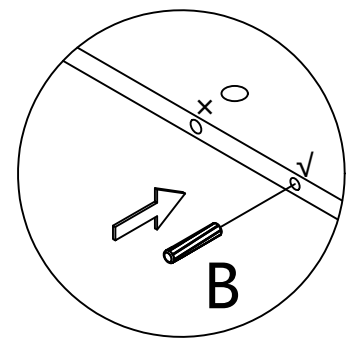
**B**

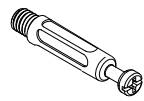
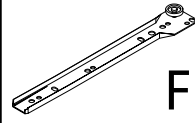
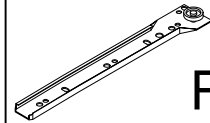
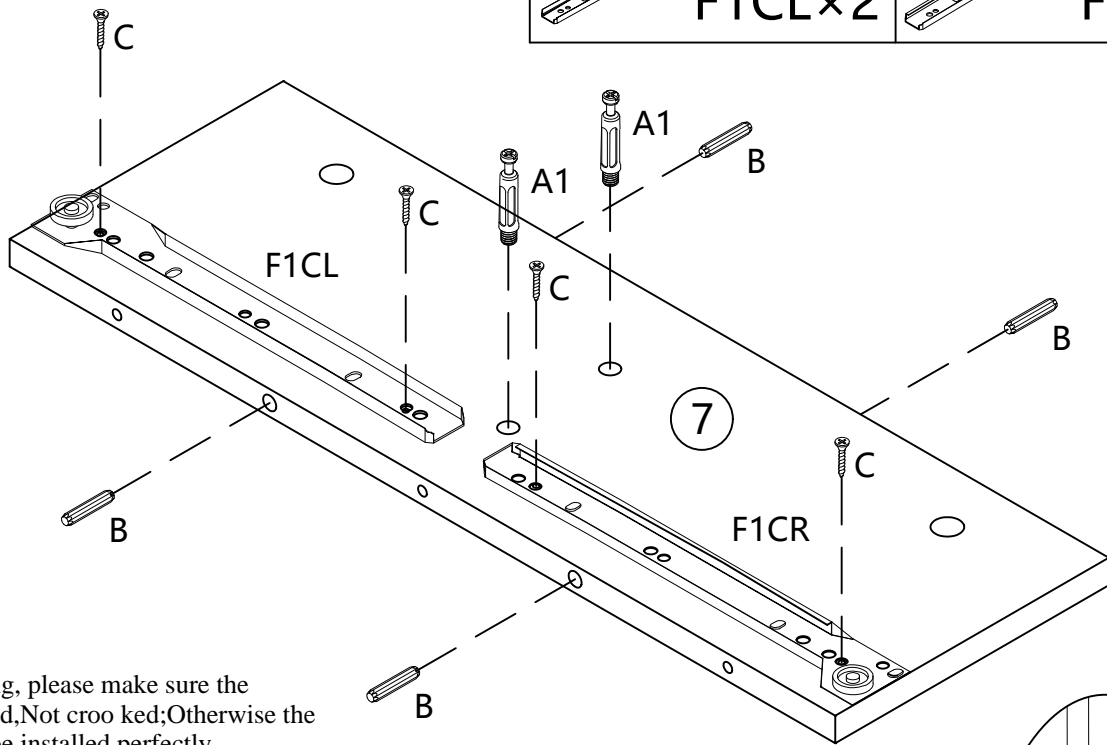
4**A1×4****B×12****C×8****F1CL×2****F1CR×2**

EN:When installing, please make sure the screws are flattened,Not croo ked;Otherwise the drawers will not be installed perfectly.

DE:Achten Sie bei der Montage darauf, dass die Schrauben abgeflacht und nicht schief sind. Andernfalls werden die Schubladen nicht perfekt montiert.

FR:Lors de l'installation, assurez-vous que les vis sont aplaties et non tordues ; sinon, les tiroirs ne seront pas parfaitement installés.

IT:Durante l'installazione, assicurarsi che le viti siano appiattite e non storte, altrimenti i cassetti non verranno installati perfettamente.

ES:Al instalar, asegúrese de que los tornillos estén planos, no torcidos; de lo contrario, los cajones no se instalarán perfectamente.

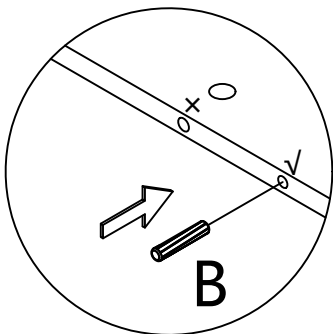
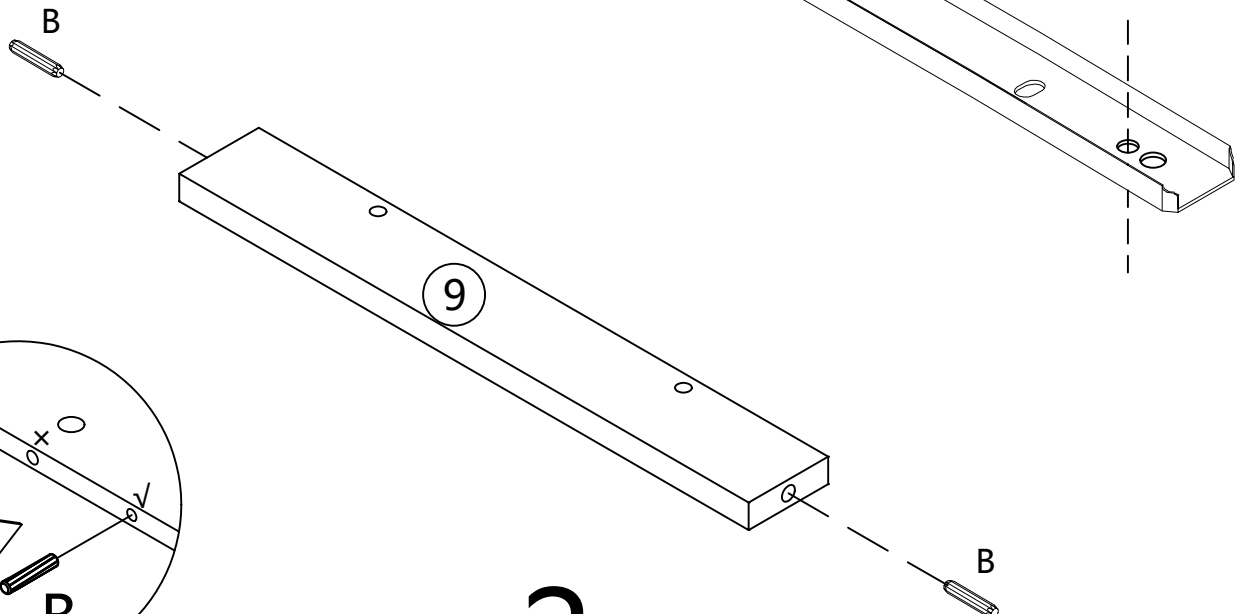
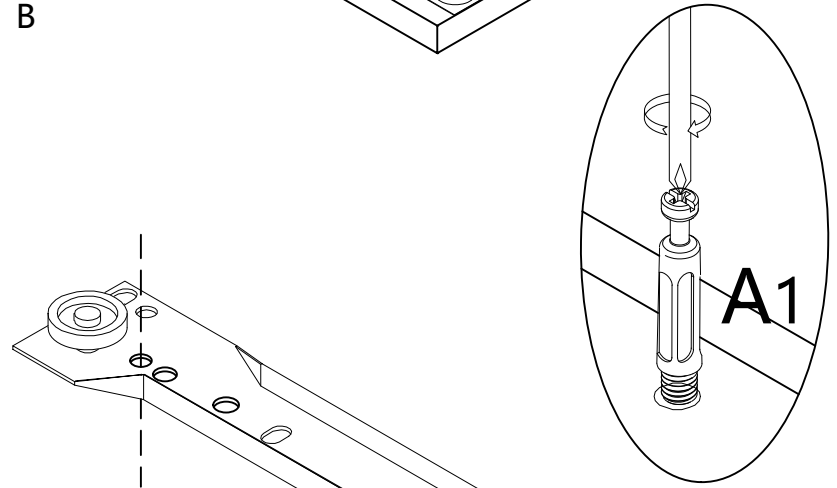
**×2**

5

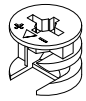

A2×8

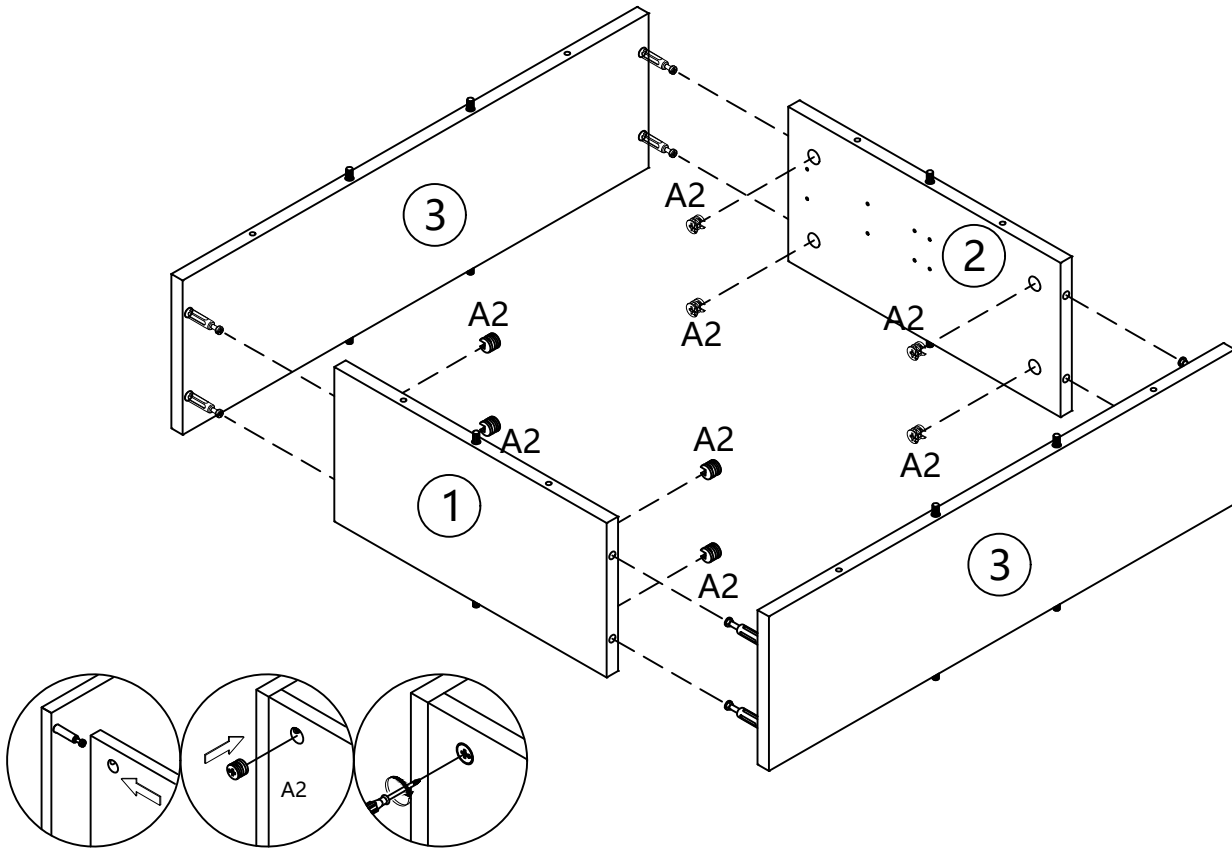

6



E×8

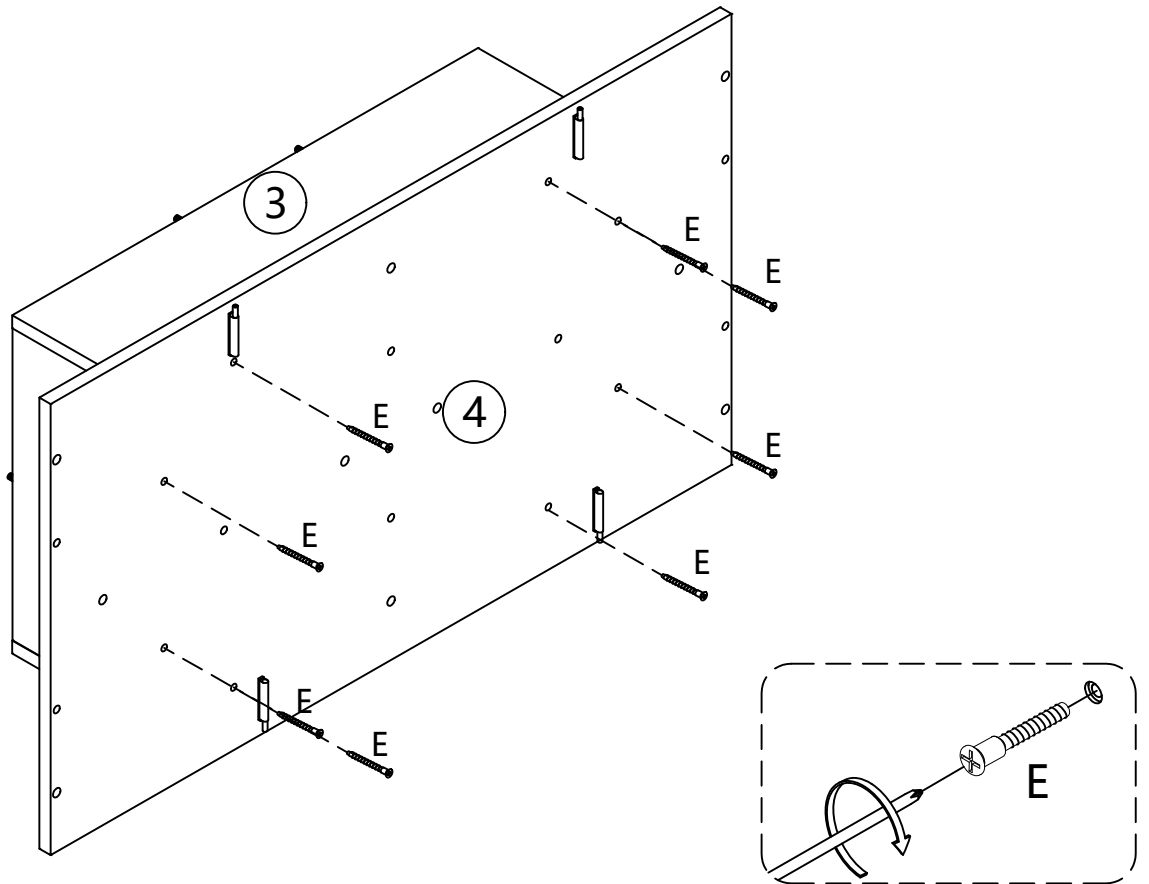

7

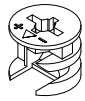

A2x4

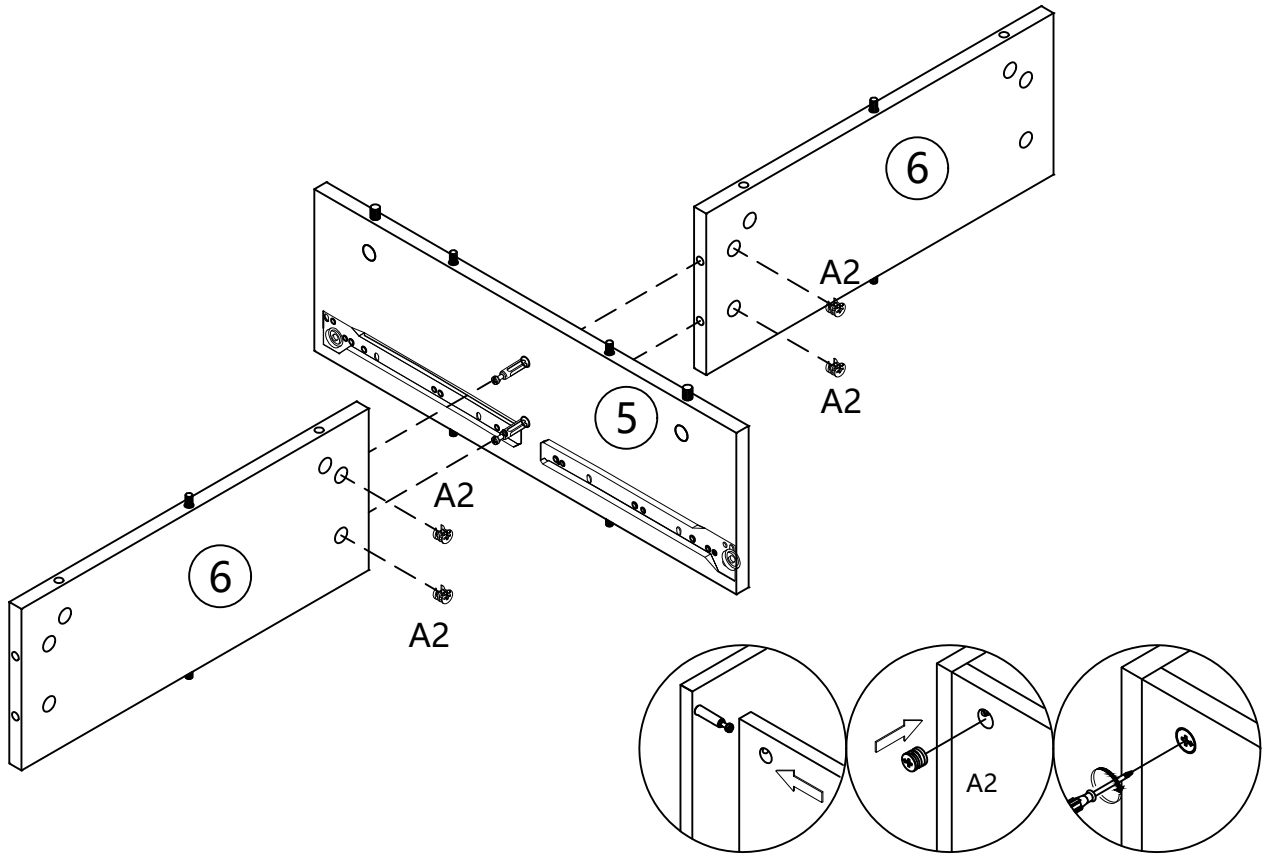

8

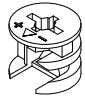

A2x4

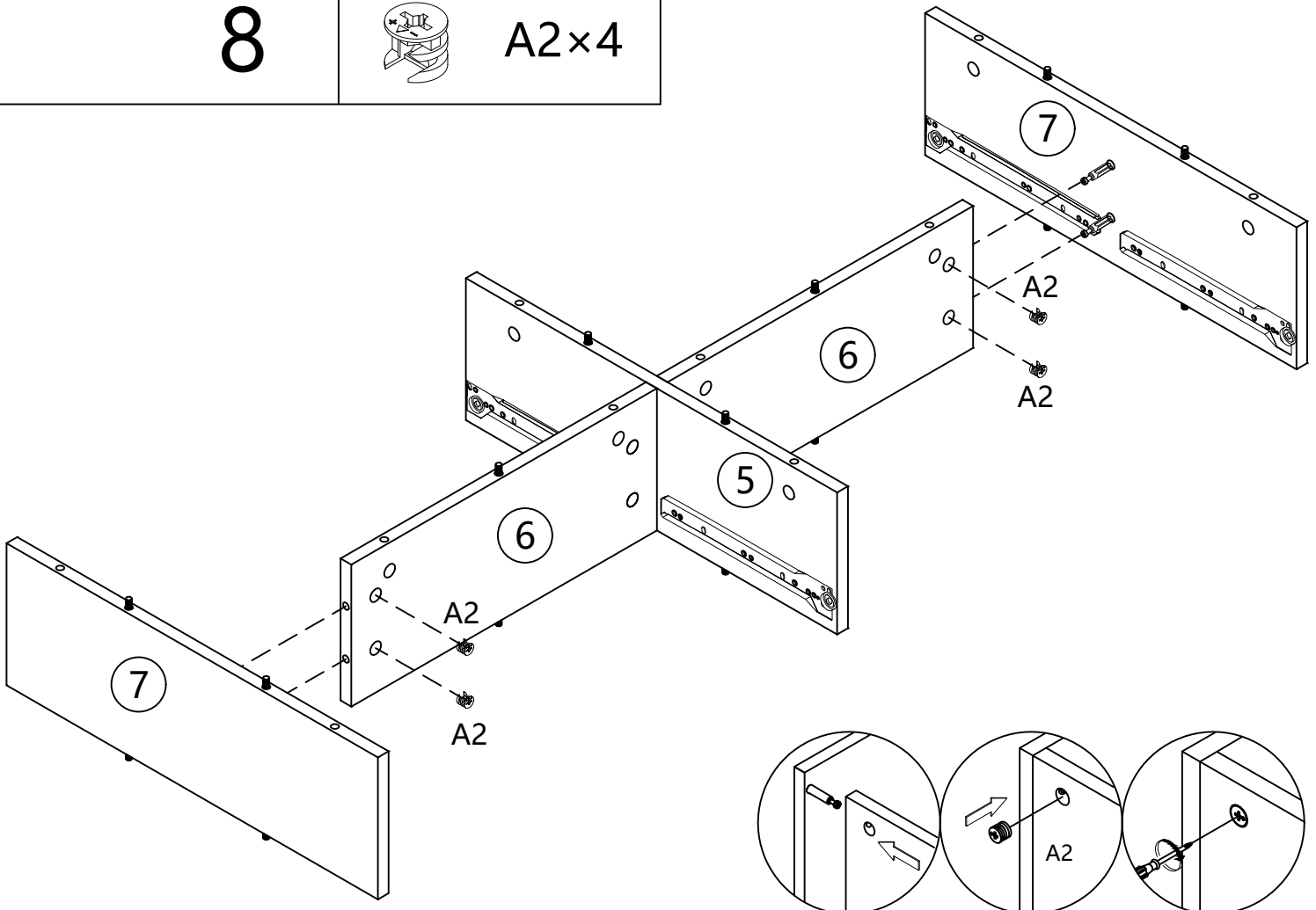

9

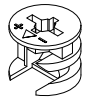

A2x10

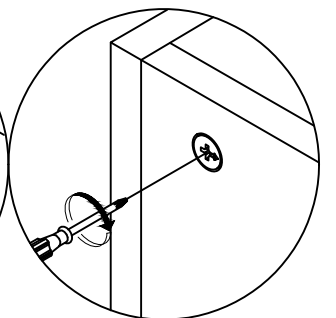
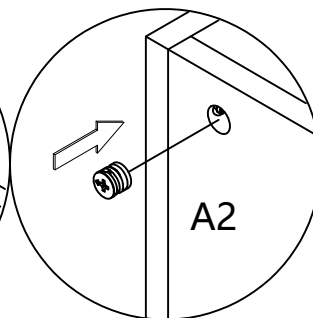
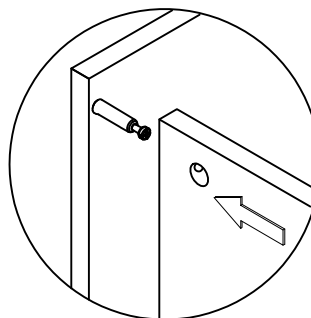
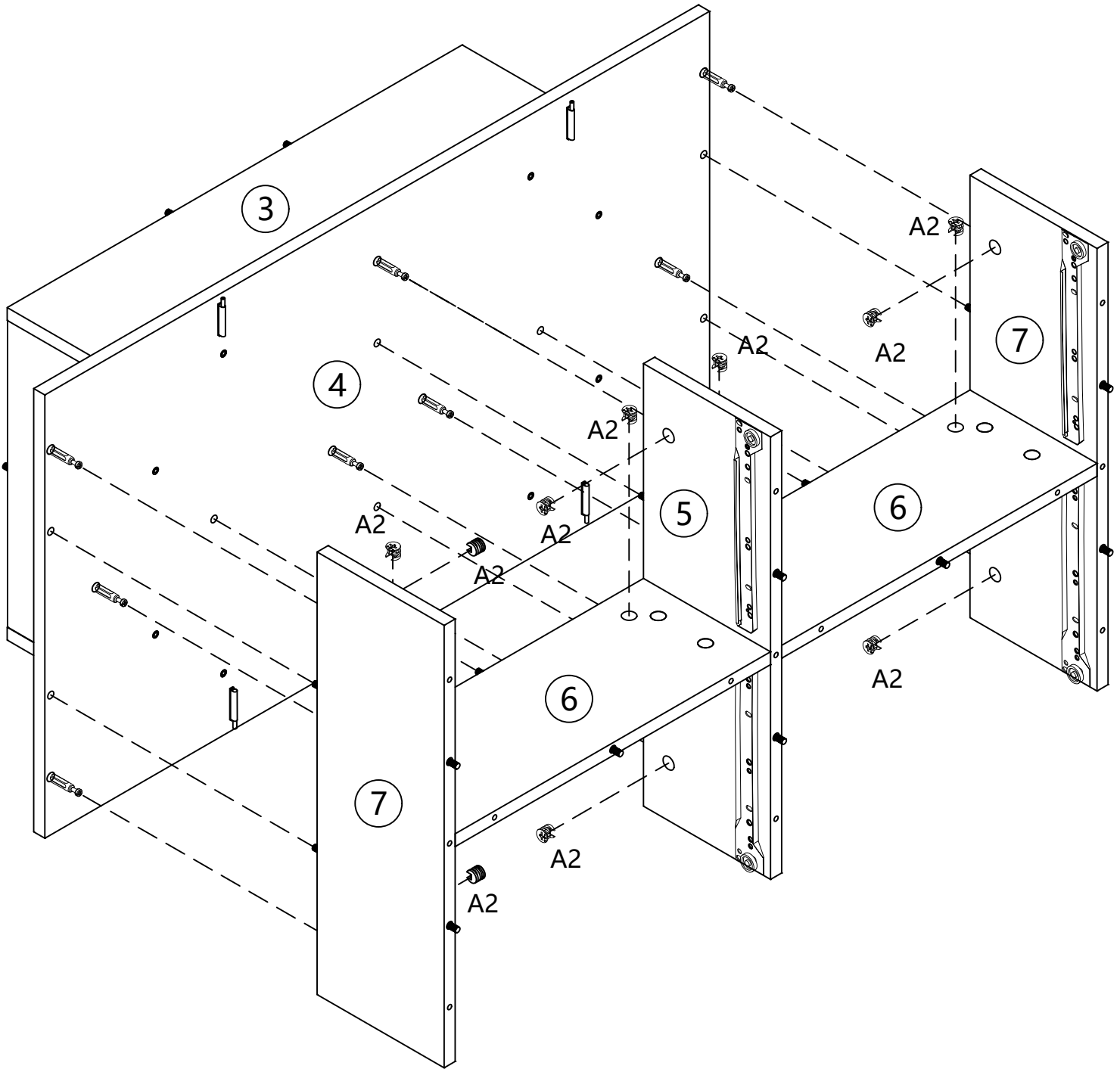

10

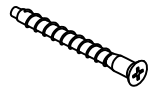

E x 13



J x 6

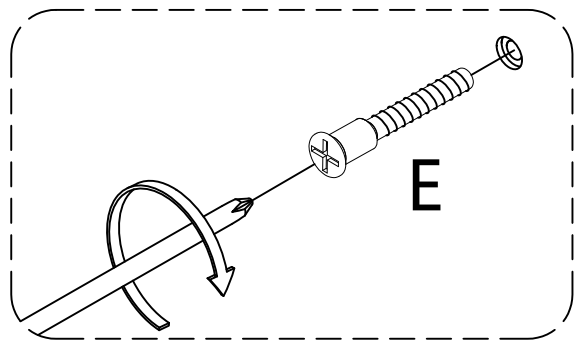
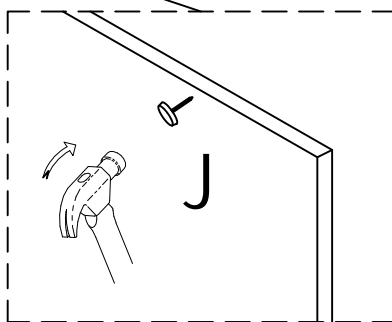
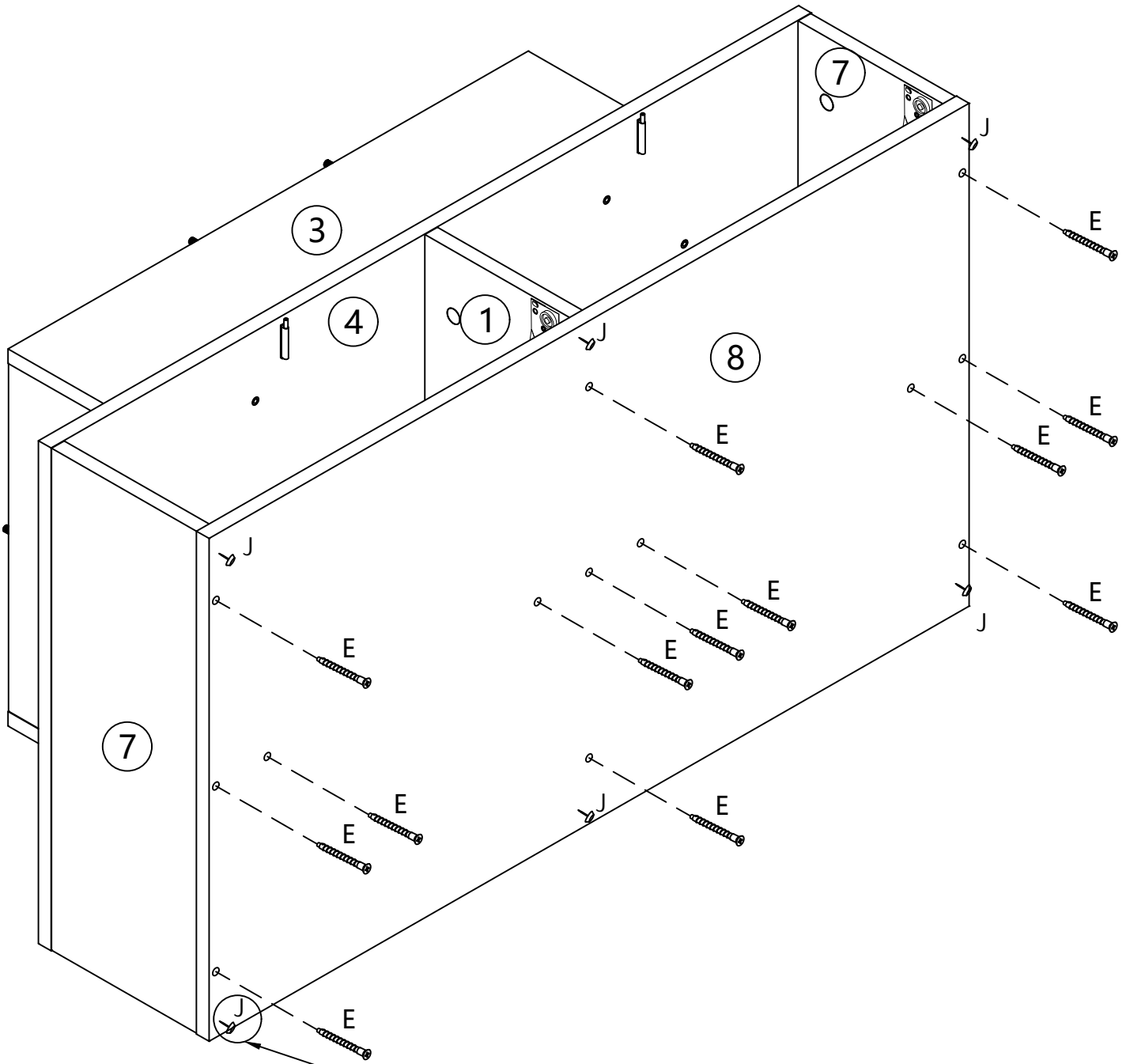

11

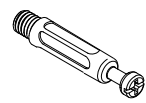

A1x8

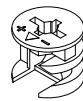

A2x8

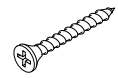

Dx8

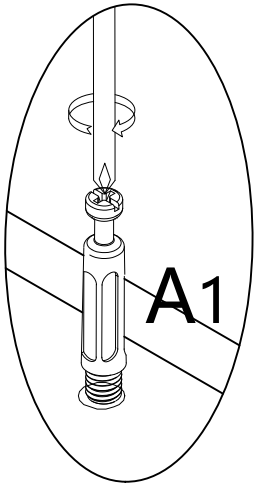

A1

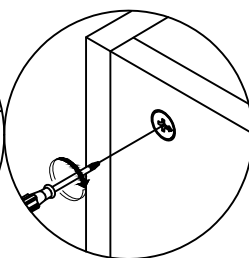
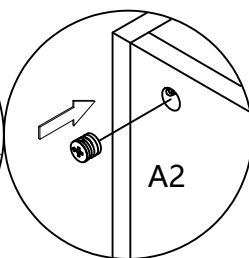
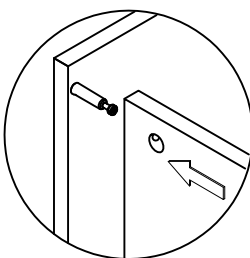
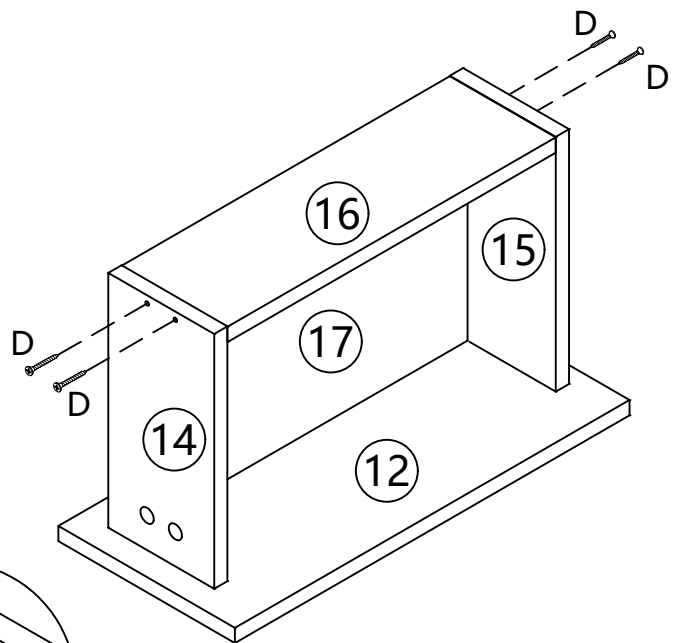
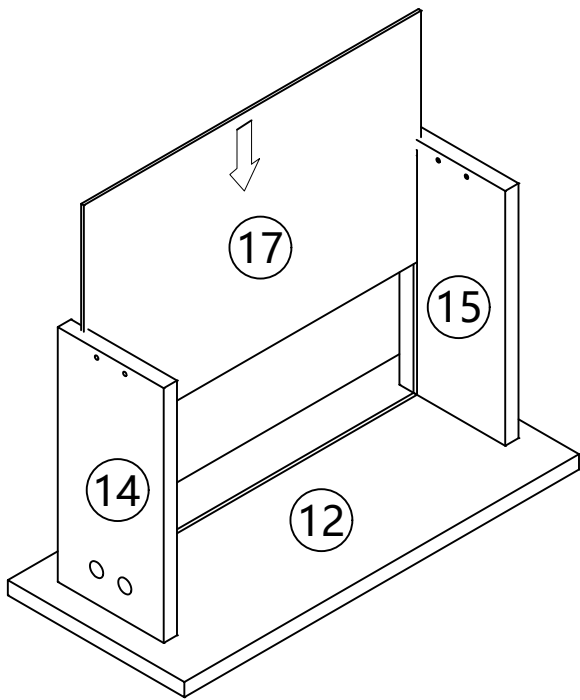
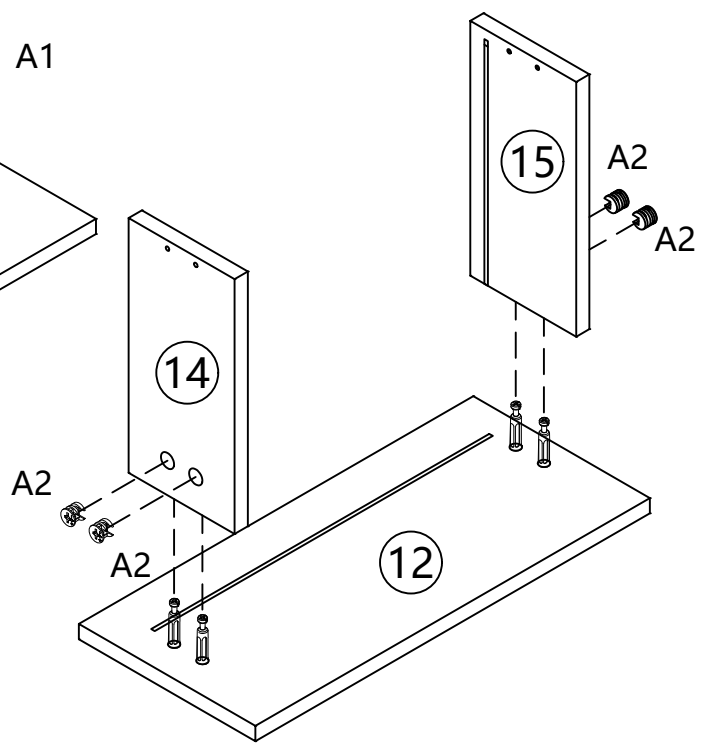
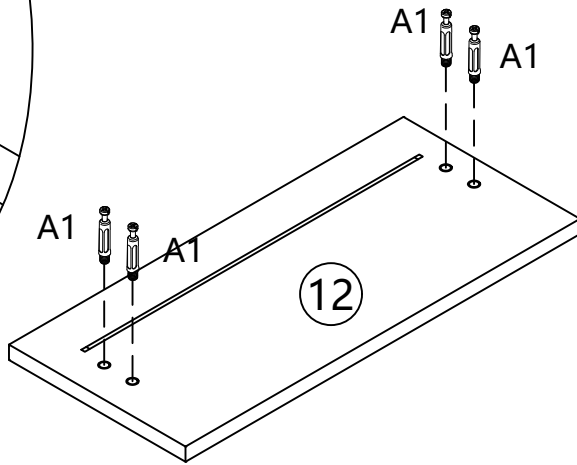

x2

12

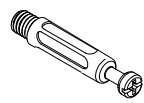

A1×8

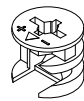

A2×8

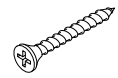

D×8

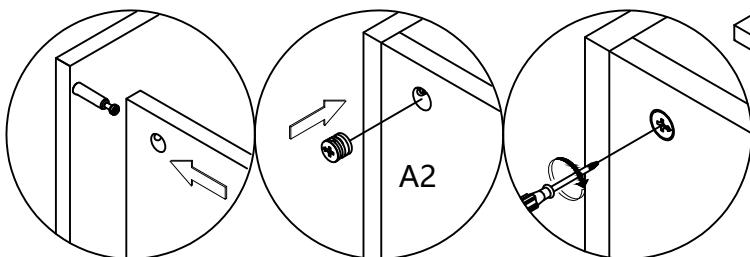
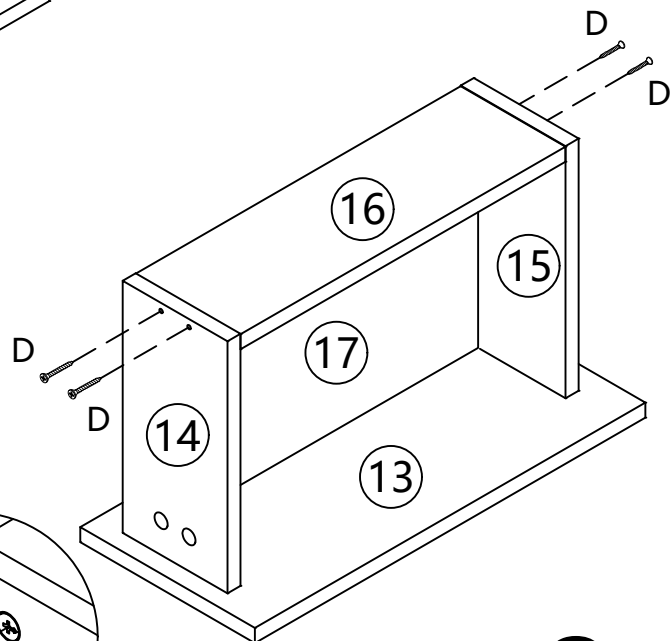
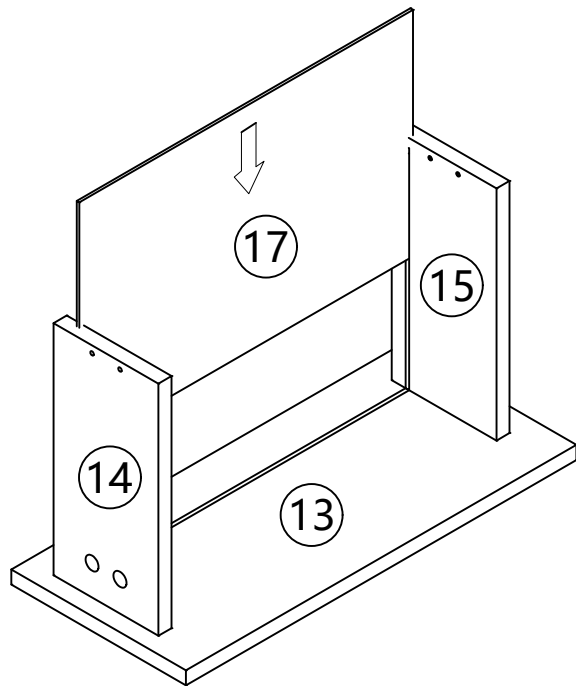
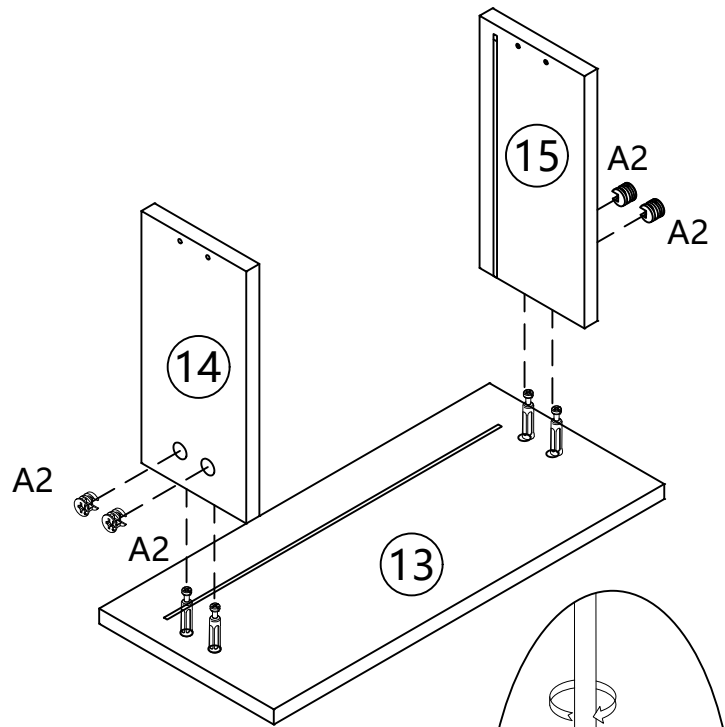
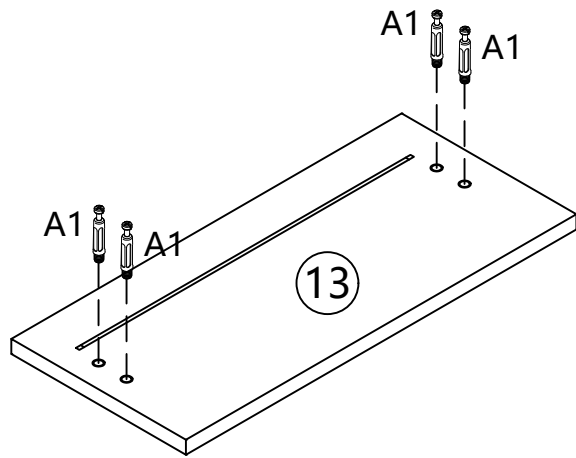

×2

13



C×16

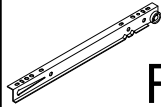

F2DL×4

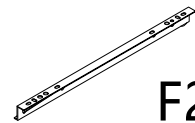

F2DR×4

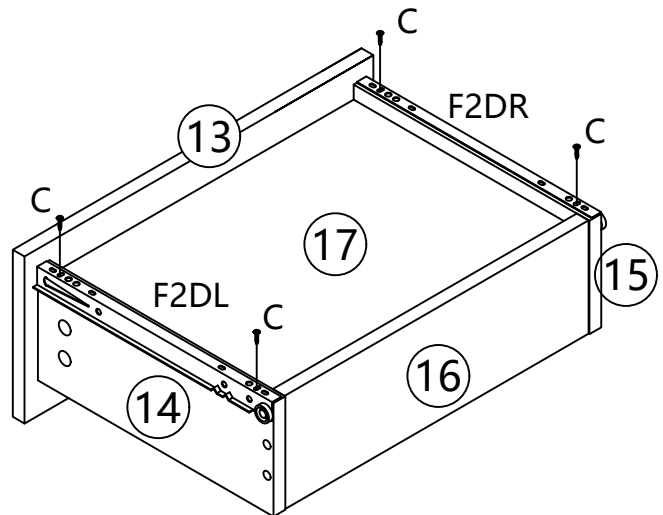
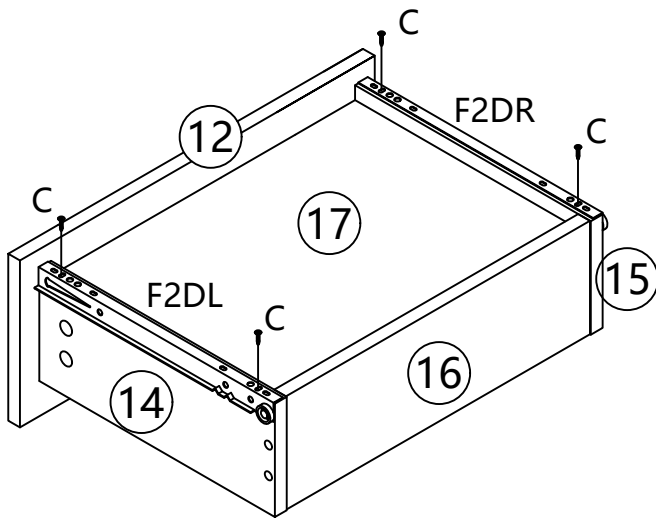
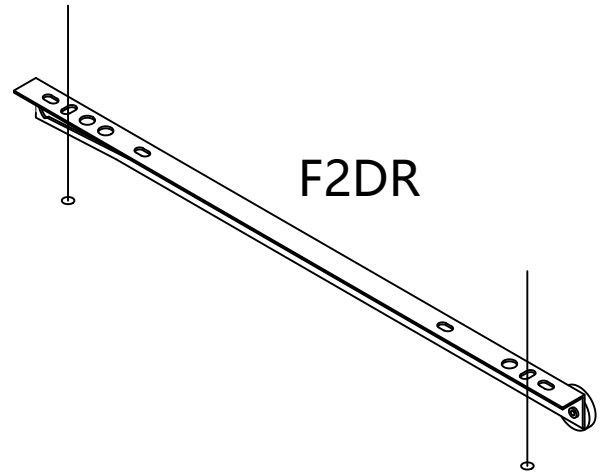
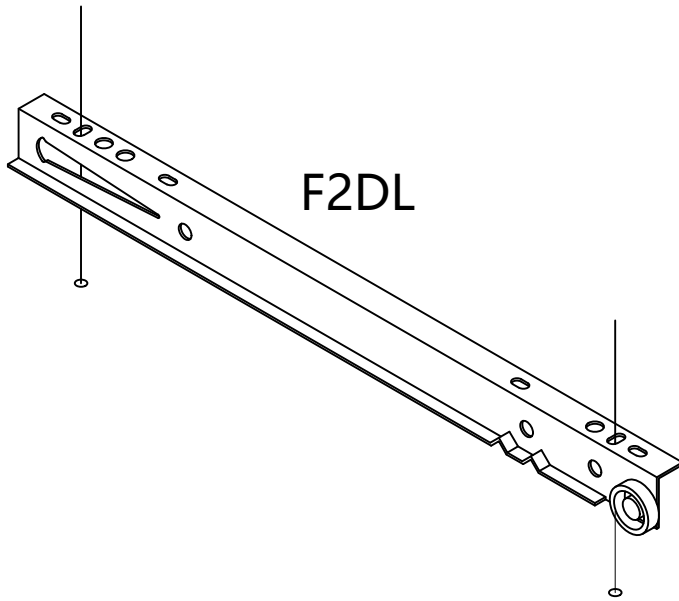

×2

14

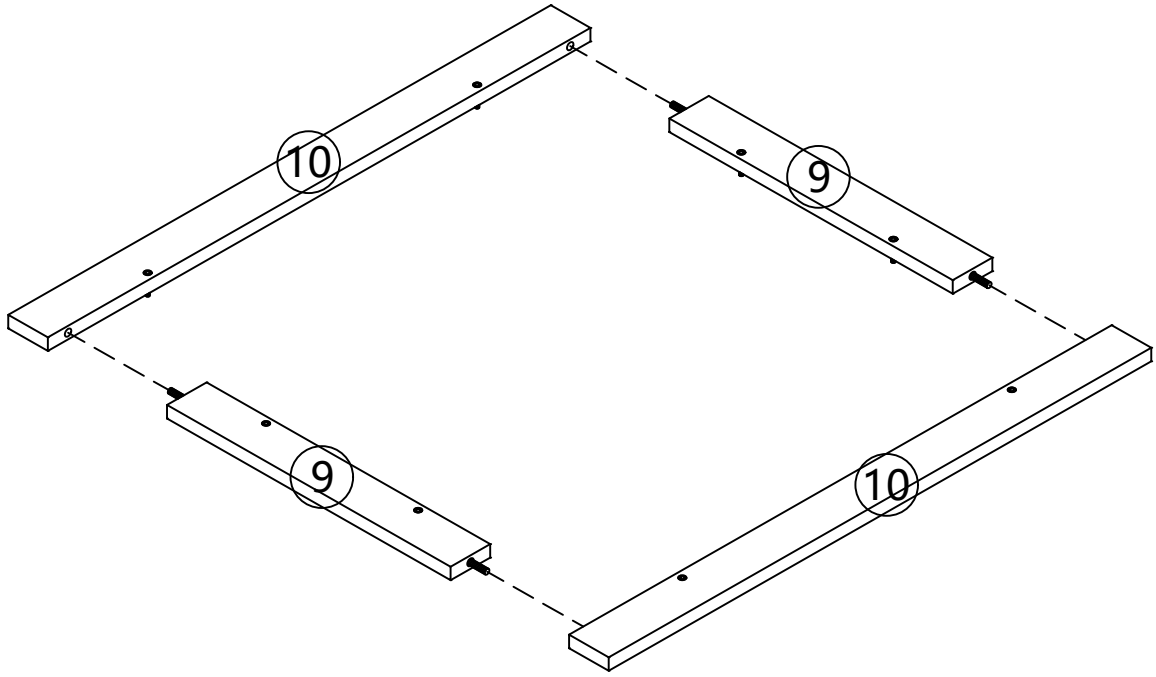

15

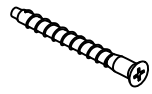

E×8

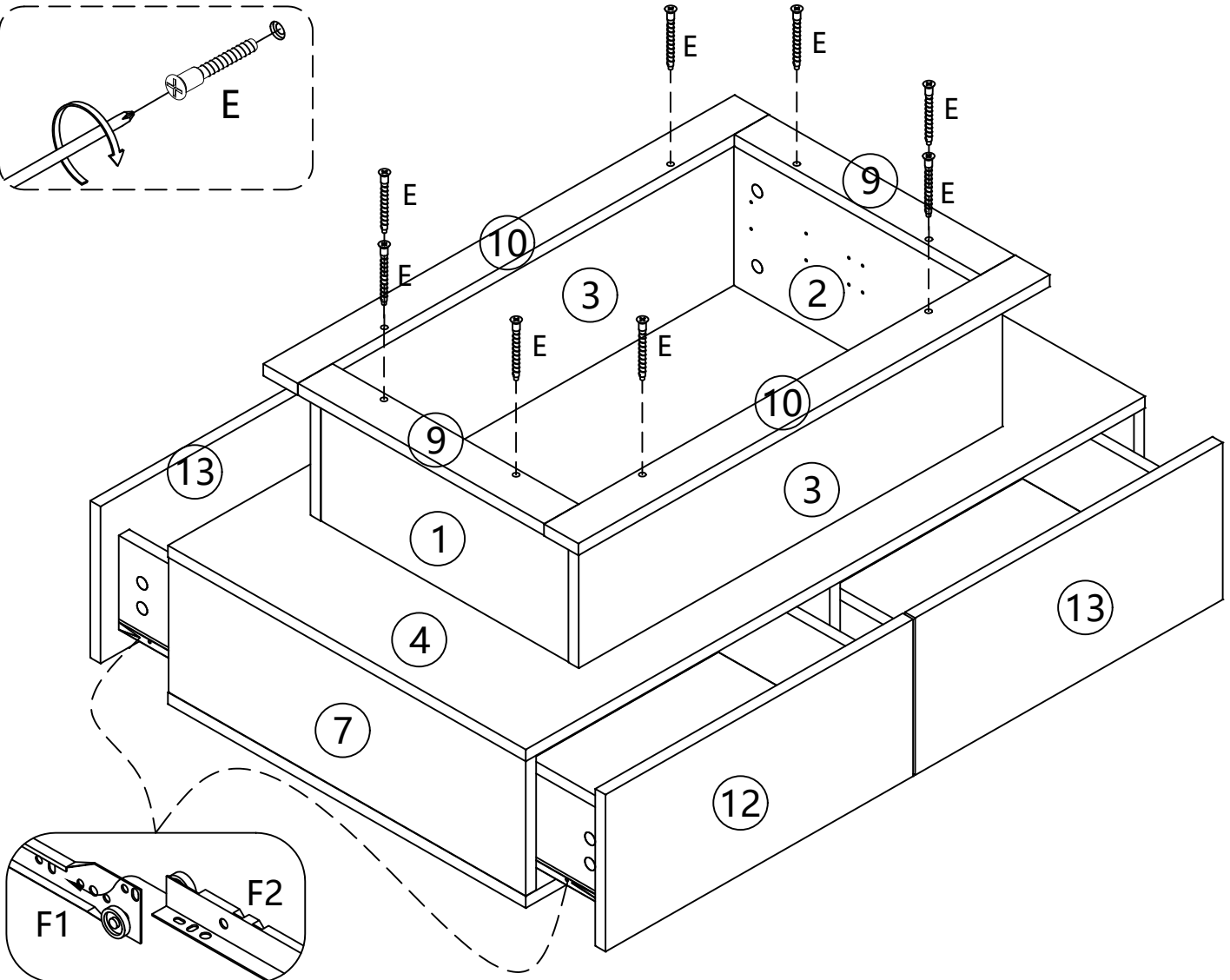
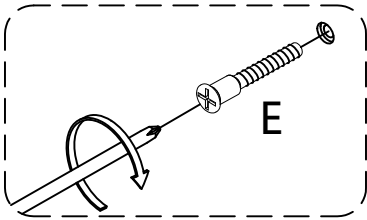

16



K×16

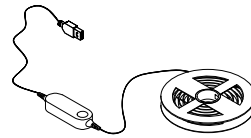

L×1

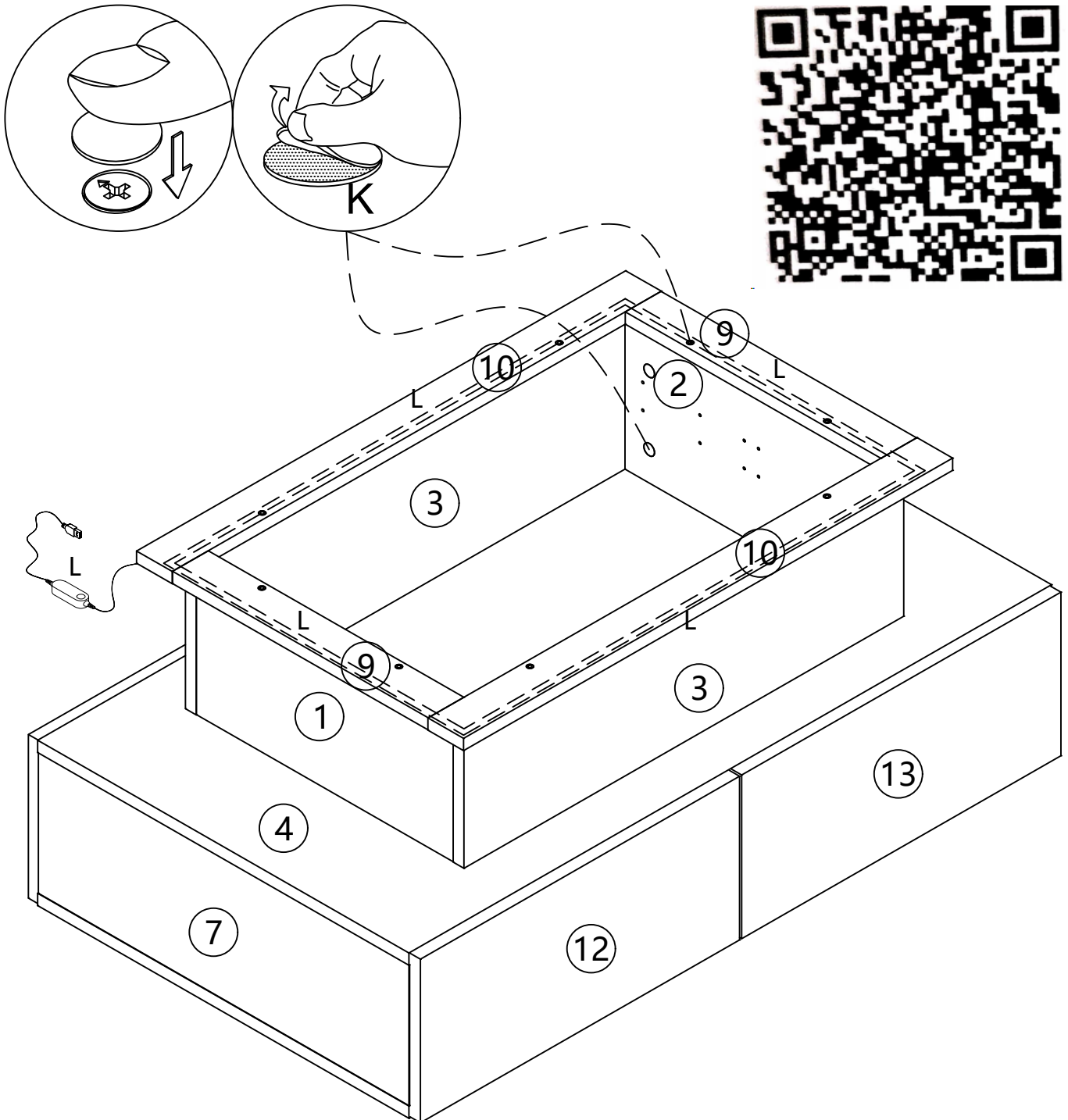

DE: Durch Drehen dieser Position der Teile K können Sie den Abstand zwischen der Tür und der oberen Platte anpassen.

EN: By rotating this position of parts K, you can adjust the gap between the door and the top panel.

FR: En tournant cette position des pièces K, vous pouvez ajuster l'espace entre la porte et le panneau supérieur.

IT: Ruotando questa posizione delle parti K, è possibile regolare lo spazio tra la porta e il pannello superiore.

ES: Al girar esta posición de las piezas K, puede ajustar el espacio entre la puerta y el panel superior.

17

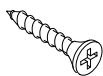

C×10

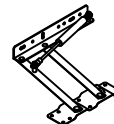
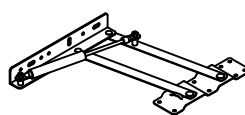

H×1

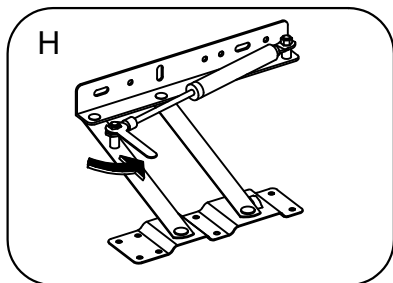

EN:Loosen the screws here,as shown.
 DE:Lösen Sie hier, wie gezeigt, die Schrauben.
 FR:Desserrez les vis ici, comme indiqué.
 IT:Allentare le viti qui, come mostrato.
 ES:Afloje los tornillos aquí, como se muestra.

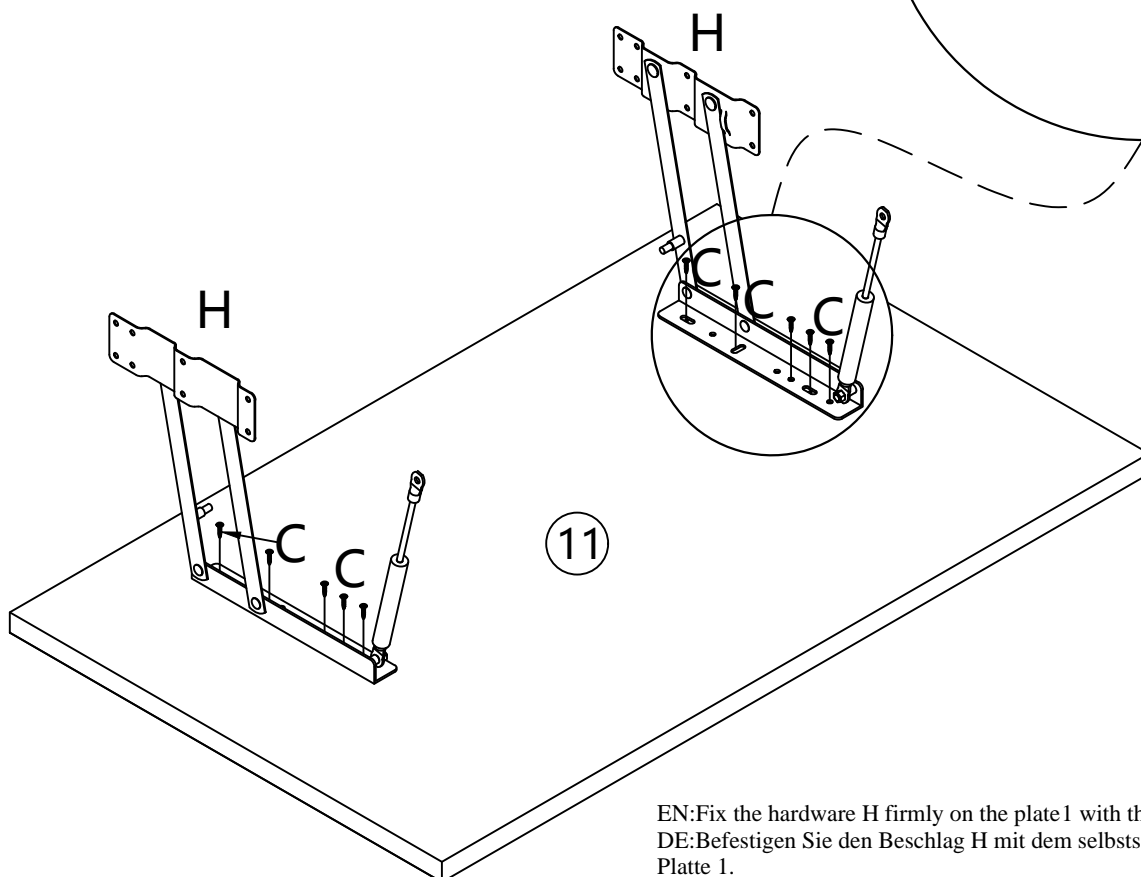
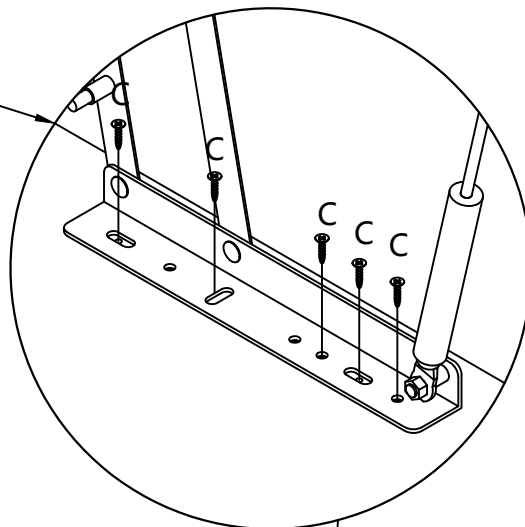

EN:Fix the hardware H firmly on the plate 1 with the self-tapping thread C,
 DE:Befestigen Sie den Beschlag H mit dem selbstschneidenden Gewinde C fest auf der
 Platte 1.
 FR:Fixer fermement la quincaillerie H sur la plaque 1 avec le filetage autotaraudeur C,
 IT:Fissare saldamente la ferramenta H sulla piastra 1 con la filettatura autofilettante C,
 ES:Fije el hardware H firmemente en la placa 1 con la rosca autorroscante C,

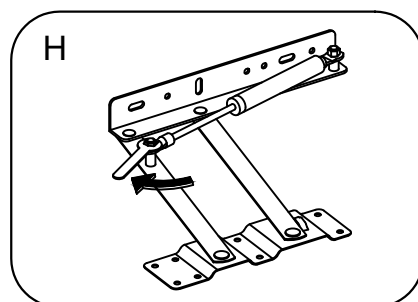

EN:Tighten the screws on hardware H here.
 DE:Dabei die Schrauben am Beschlag H festziehen.
 FR:Serrez les vis sur le matériel H ici.
 IT:Stringere le viti sull'hardware H qui.
 ES:Apriete los tornillos en el hardware H aquí.

18



C×16

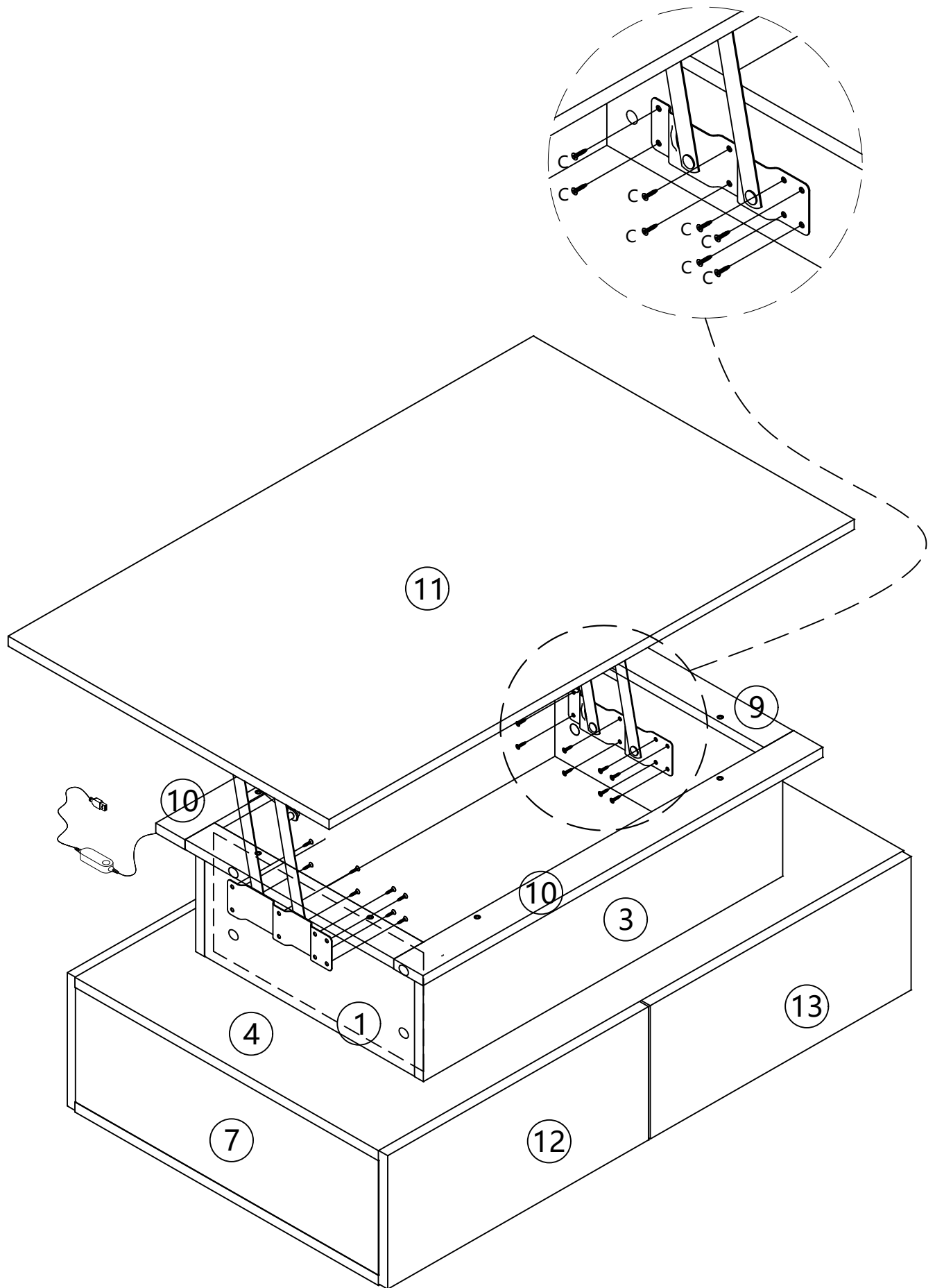

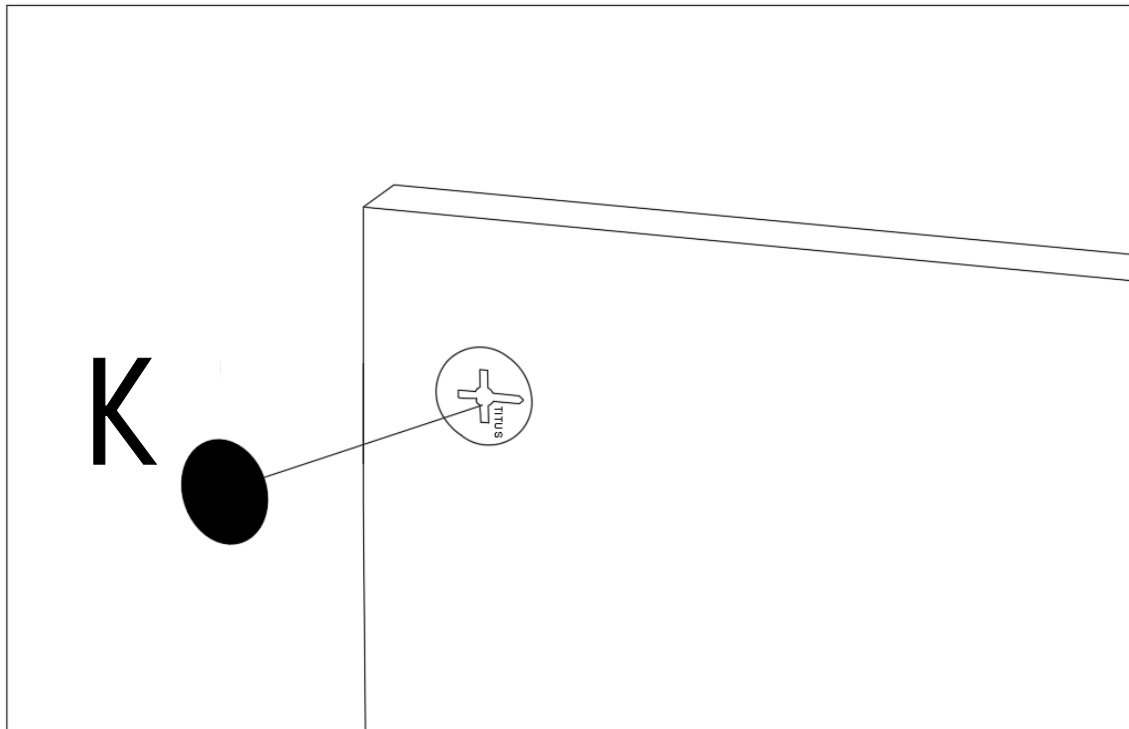

EN:In order to make the product more beautiful,please paste hardware K on the exposed holes.

DE:Um das Produkt noch schöner zu machen, kleben Sie bitte Hardware K auf die freiliegenden Löcher.

FR:Afin de rendre le produit plus beau, s' il vous plaît coller le matériel K sur les trous exposés.

IT:Per rendere il prodotto più bello, incollare l' hardware K sui fori esposti.

ES:Con el fin de hacer el producto más hermoso, por favor pega hardware K en los agujeros expuestos



[DE]

BITTE BEACHTEN: Teilenummer 1 1 . 1 2 . 1 3 st mit einer dichten Kunststoffschutzfolie überzogen. Wenn das Produkt nach der Demontage Kratzer aufweist, machen Sie sich bitte keine Sorgen, es handelt sich nicht um einen Produktschaden.

Bitte ziehen Sie die schützende Kunststoffolie langsam entlang der Kante von der Oberfläche ab. Nach dem Abziehen wird das Produkt glatt und sauber.

[EN]

PLEASE NOTE: Part number 1 1 . 1 2 . 1 3 are covered with a tight plastic protective film.

If there are scratches on the product after disassembly, please don't worry, it's not product damage.

Please slowly tear off the protective plastic film on the surface along the edge. After peeling off, the product becomes smooth and clean.

[FR]

REMARQUE : les pièces numéro 1 1 . 1 2 . 1 3 sont recouvertes d'

un film protecteur en plastique étanche. Si le produit présente des rayures après le démontage, ne vous inquiétez pas, il ne s'agit pas d'un dommage au produit.

Retirez lentement le film protecteur en plastique sur la surface le long du bord. Une fois décollé, le produit devient lisse et propre.

[IT]

NOTA BENE: il numero di parte 1 1 . 1 2 . 1 3 è coperto da una pellicola protettiva in plastica stretta.

Se ci sono graffi sul prodotto dopo lo smontaggio, non preoccuparti, non è un danno al prodotto.

Strappare lentamente la pellicola protettiva in plastica sulla superficie lungo il bordo. Dopo averla staccata, il prodotto diventa liscio e pulito.

[ES]

NOTA: La pieza número 1 1 . 1 2 . 1 3 está cubierta con una película protectora de plástico.

Si hay rayones en el producto después de desmontarlo, no se preocupe, no se trata de daños en el producto. Retire lentamente la película protectora de plástico de la superficie a lo largo del borde.

Después de despegarla, el producto quedará liso y limpio.

Verification of Compliance

Verification No.: TMC210319126-E

Name and address of Applicant: **Shenzhen CWG Technology Co., Ltd**
5 / F, No.264 Baoshi East Road, Shiyan street, Bao'an District, Shenzhen,China 518108

Name and address of Manufacturer: **Shenzhen CWG Technology Co., Ltd**
5 / F, No.264 Baoshi East Road, Shiyan street, Bao'an District, Shenzhen,China 518108

Product name: **LED Strip**

Rated: DC12V

Product model(s): CWG-5050RGB-60D-12V , additional models reference attachment

Product trademark: 创唯光

This verification confirms that the product meets the requirements of the following standard.
The conformity was demonstrated based on following standard(s) listed by European Commission as harmonized with EMC Directive 2014/30/EU.

EN IEC 55015:2019+A11:2020
IEC 61547:2020

The verification has been carried out in accordance with individual rules and conditions agreed with the applicant. Evaluation has been carried out in accordance with:

Test report(s) No.: TMC210319126-E

Test conducted by: TMC Testing Services (Shenzhen) Co., Ltd.

Verification issue date: March 26, 2021

Notes:

This verification refers to the above mentioned product and its conformity in regards of above mentioned standard(s) was proven on test sample.

This verification does not imply meeting all essential requirements, assessment of the series-production or any other restricted Notified Bodies conformity assessment procedure appropriate for the product.

This verification holder shall use this verification in connection to verification of conformity and technical data relevant for the product the verification was issued.

TMC Testing Services (Shenzhen) Co., Ltd.

t:86-755-86642861 cert@tmc-lab.com www.tmc-lab.com

1st Floor, Block A1, Zone A, Xinshidai Gongrong Industrial Park, No. 2, Shihuan Road, Shiyan Street, Baoan District, Shenzhen, China

