

## Upholstered bed N652P248141/N652P248142

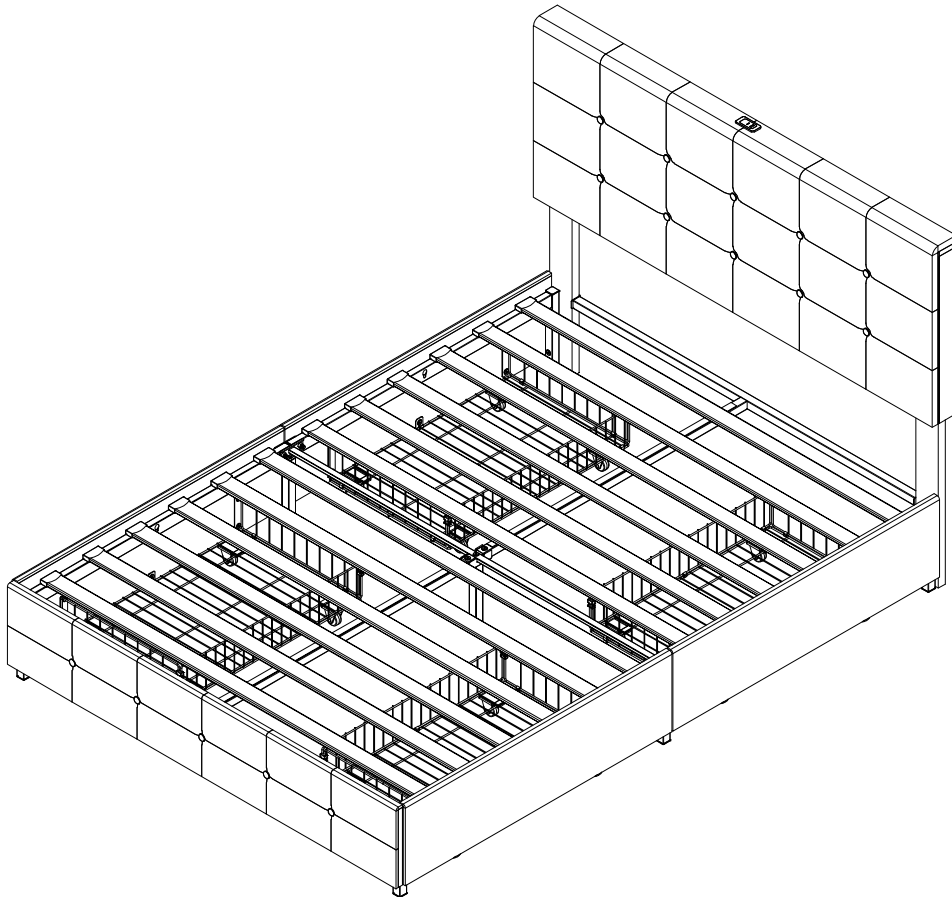

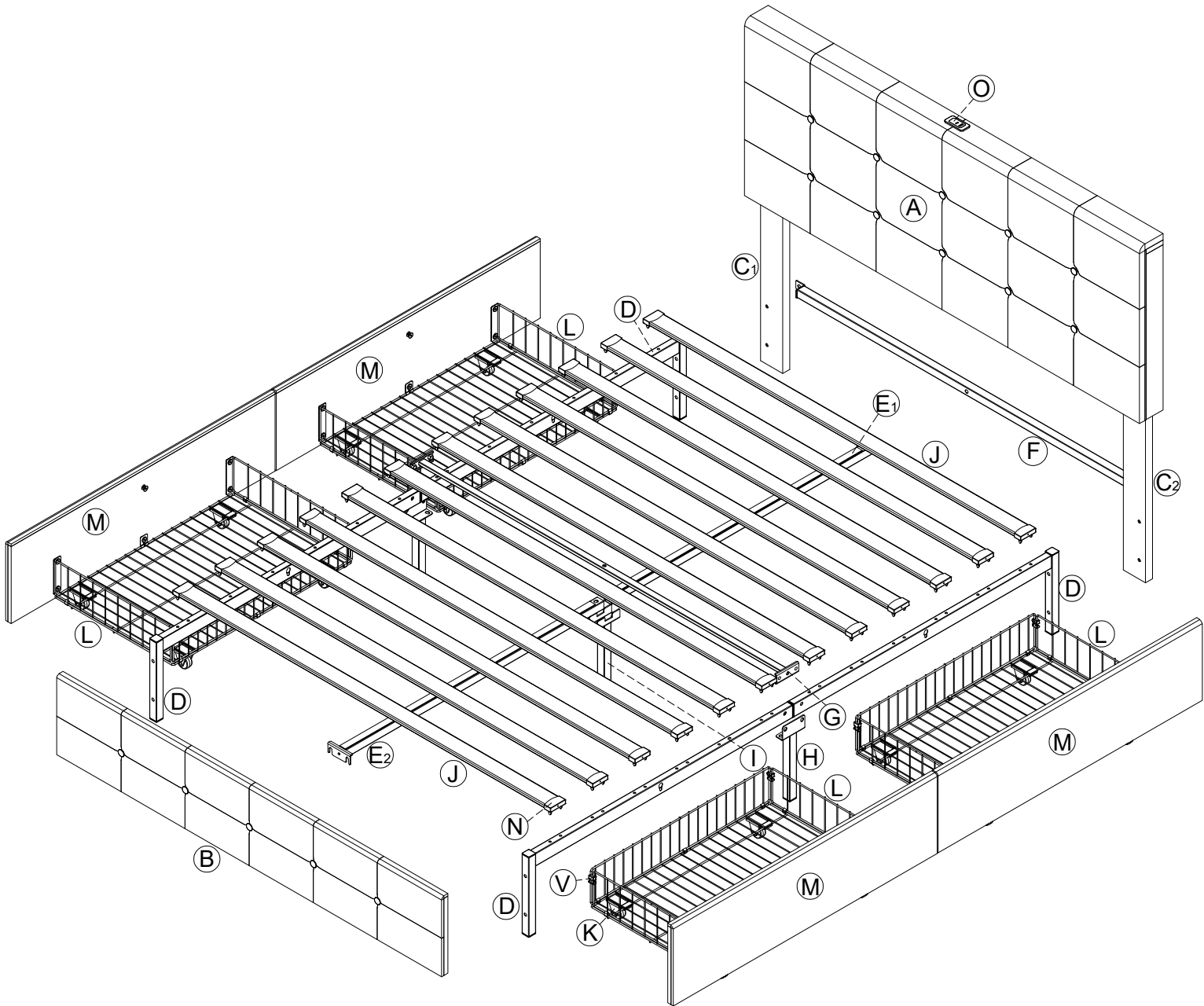







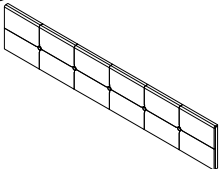

### TIPS

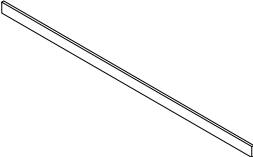
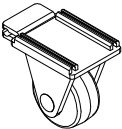
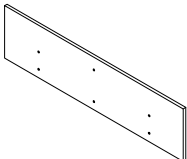
1. Please read the instructions fully before assembly. These instructions include important information which could ensure correct assembly. We have been working on providing high quality products for you. However, in the rare instance that your product is defective, missing parts or there are some issues, please don't hesitate to contact our customer service to submit parts requirements, assembly suggestion, or warranty claims, and we will give the best solution as soon as possible. If necessary, we need you to provide some more clear pictures of the issue.
2. Insert the screws in holes and tighten the screws, but not too tight, 70%~80% is ok, finally tighten all the screws. If some issues happened that some screws can not target to the hole or some parts are difficult to install, please adjust the tightness of the screws.

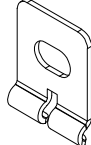
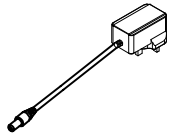
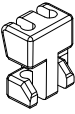
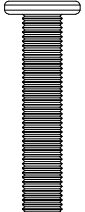

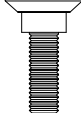

Part List N652P248141

1/2

<p><b>B</b></p>  <p>1PC</p>	<p><b>H</b></p>  <p>2PCS</p>	<p><b>I</b></p>  <p>1PC</p>	<p><b>J</b></p>  <p>12PCS</p>	<p><b>K</b></p>  <p>16PCS</p>
<p><b>M</b></p>  <p>4PCS</p>	<p><b>N</b></p>  <p>24PCS</p>	<p><b>O</b></p>  <p>1PC</p>	<p><b>P</b></p>  <p>4PCS</p>	<p><b>Q</b></p>  <p>1PC</p>
<p><b>V</b></p>  <p>8PCS</p>				
<p><b>1</b></p>  <p>M8*40 20PCS</p>	<p><b>2</b></p>  <p>M6*10 20PCS</p>	<p><b>3</b></p>  <p>M8*18 2PCS</p>	<p><b>4</b></p>  <p>M6*20 4PCS</p>	<p><b>5</b></p>  <p>M6 4PCS</p>
<p><b>6</b></p>  <p>M3*12 2PCS</p>	<p><b>7</b></p>  <p>4*80 1PC</p>	<p><b>8</b></p>  <p>4*80 1PC</p>		

Part List N652P248142

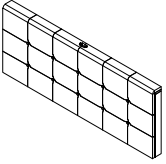
2/2

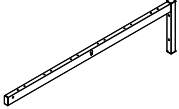
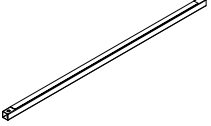
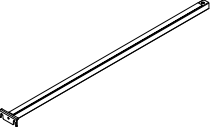
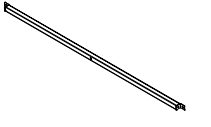
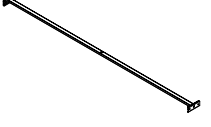
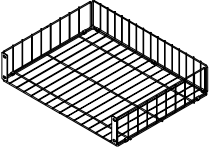
<p><b>A</b></p>  <p>1PC</p>	<p><b>C<sub>1</sub></b></p>  <p>1PC</p>	<p><b>C<sub>2</sub></b></p>  <p>1PC</p>	<p><b>D</b></p>  <p>4PCS</p>	<p><b>E<sub>1</sub></b></p>  <p>1PC</p>
<p><b>E<sub>2</sub></b></p>  <p>1PC</p>	<p><b>F</b></p>  <p>1PC</p>	<p><b>G</b></p>  <p>1PC</p>	<p><b>L</b></p>  <p>4PCS</p>	

1

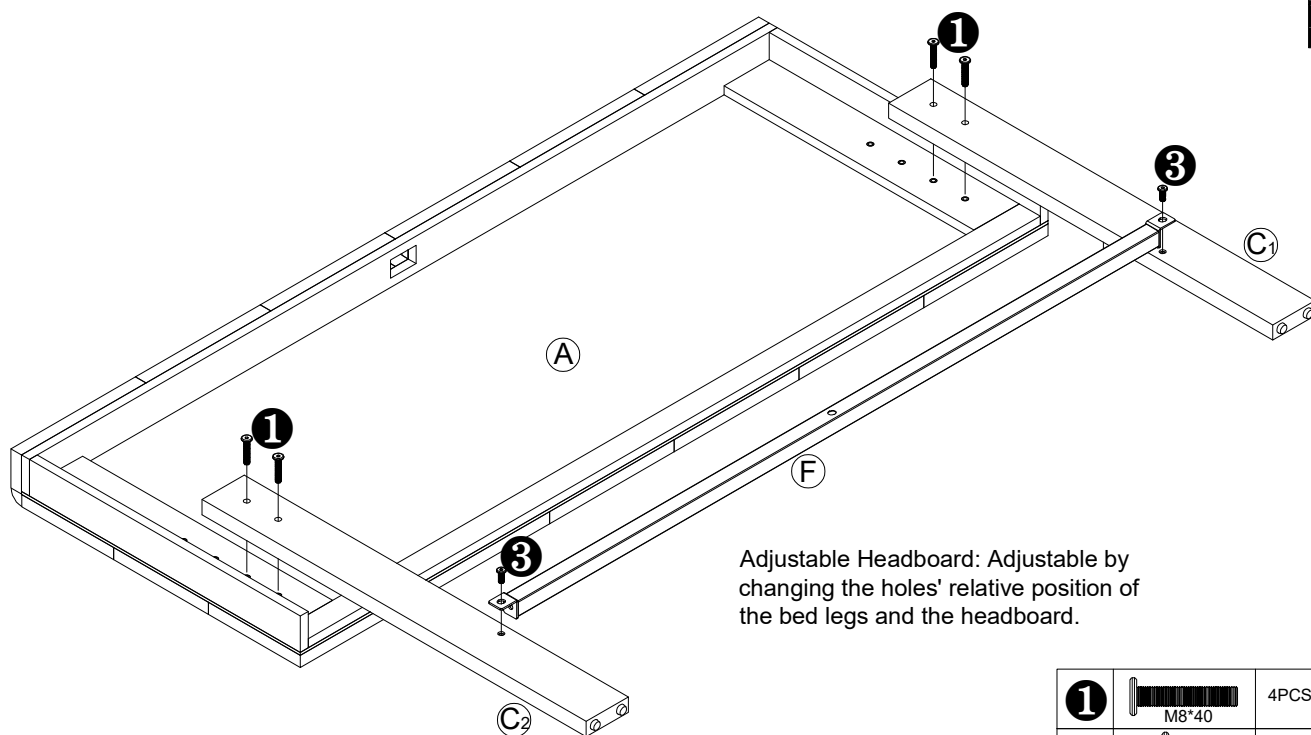

Adjustable Headboard: Adjustable by changing the holes' relative position of the bed legs and the headboard.

<b>1</b>		M8*40	4PCS
<b>3</b>		M8*18	2PCS

2

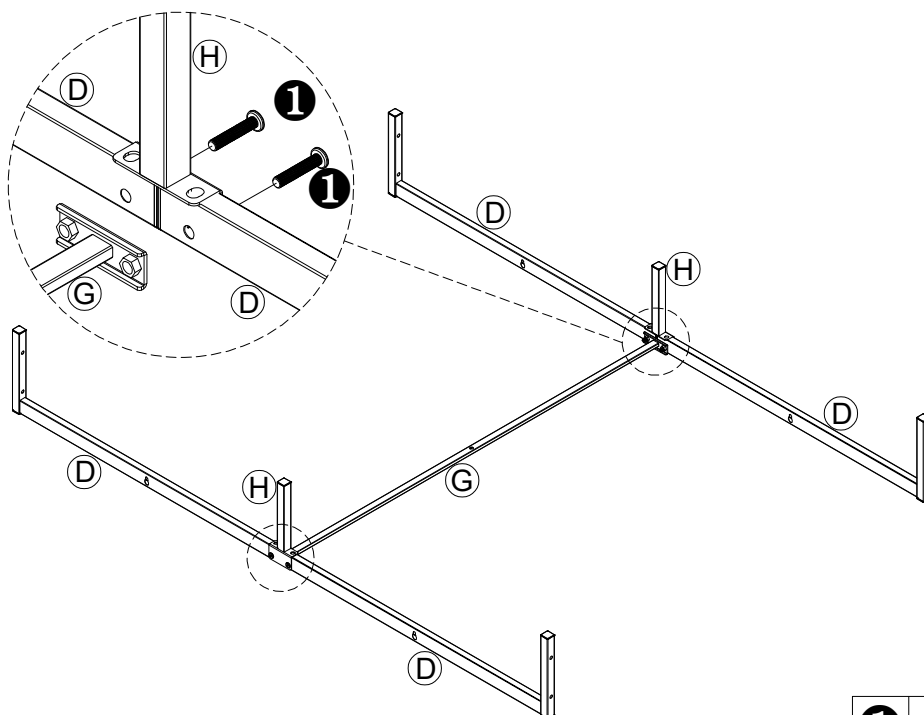

<b>1</b>		M8*40	4PCS
----------	---	-------	------

3

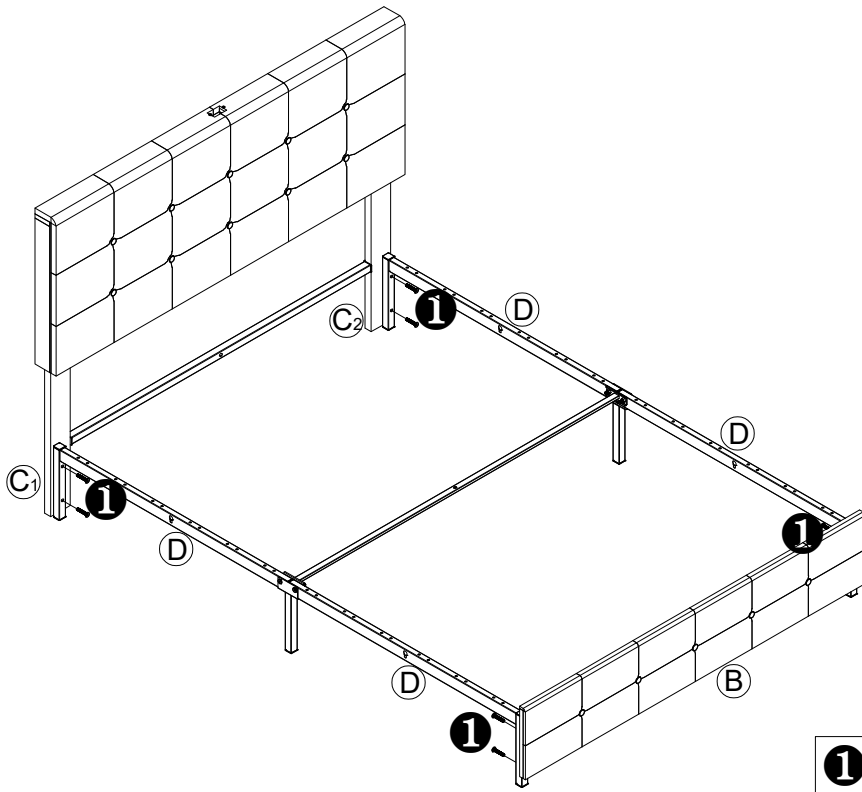

4

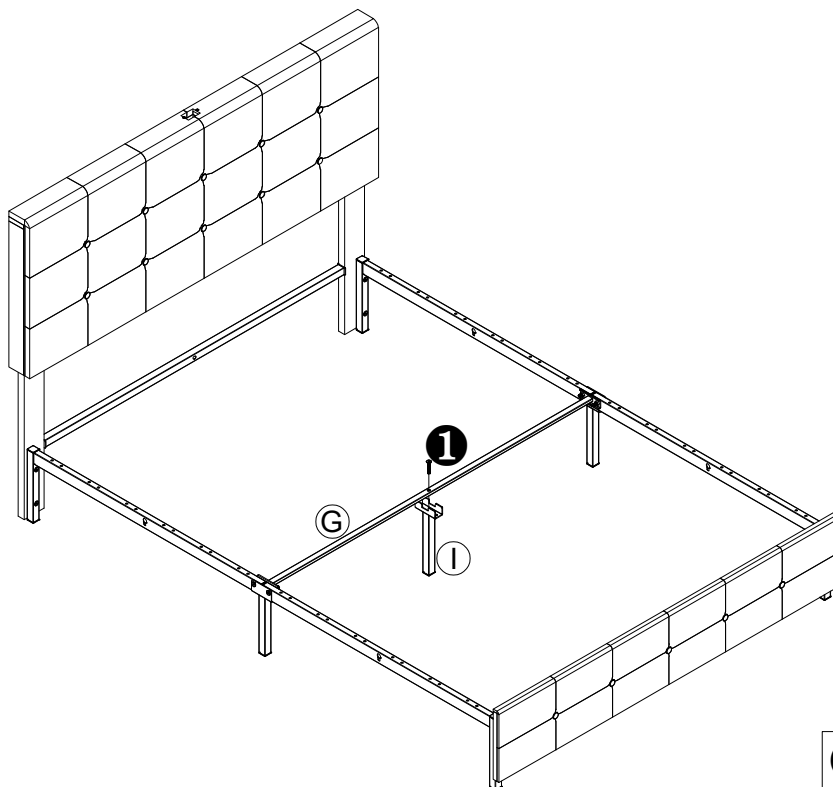

5

1. Loosen the screw first.
2. Hanging E2 on the screws.
3. Tighten the screws.

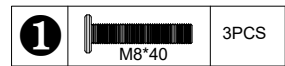
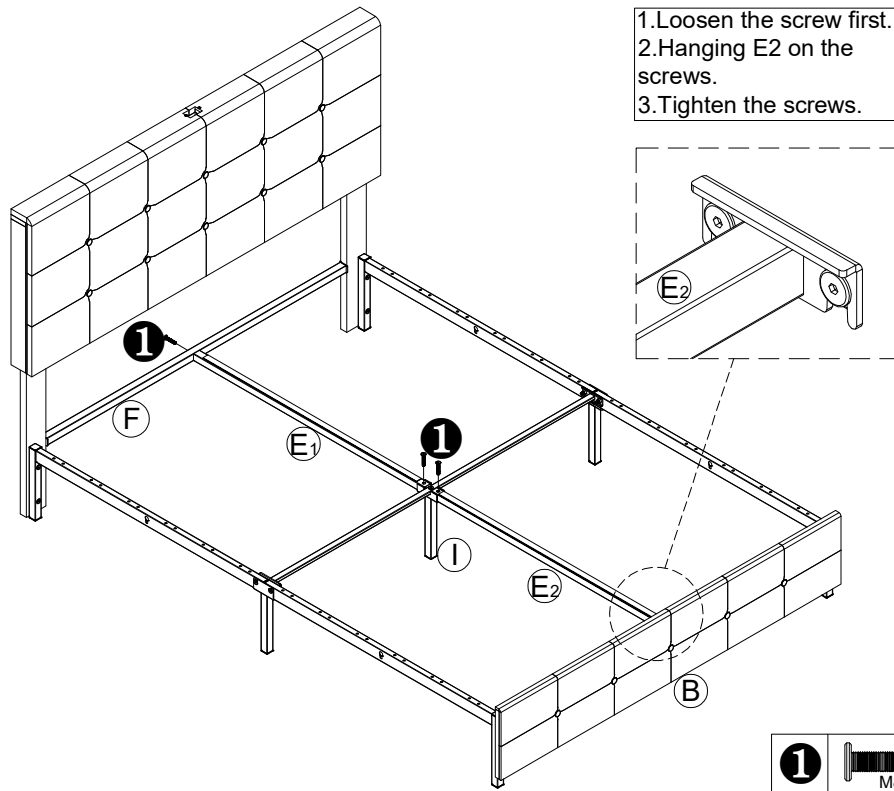

6

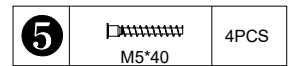
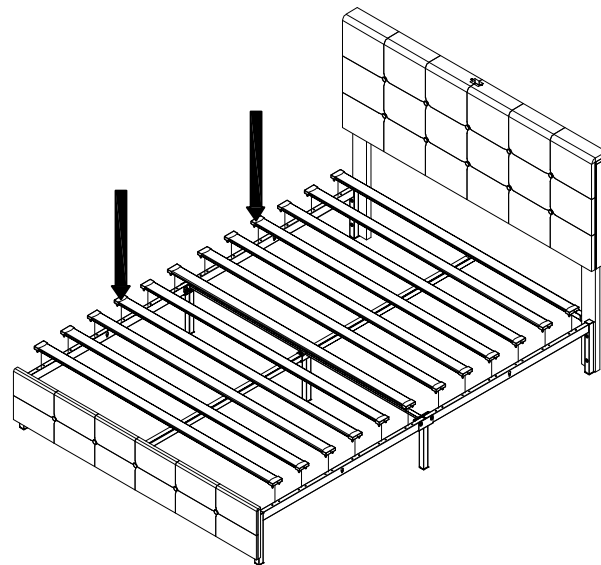
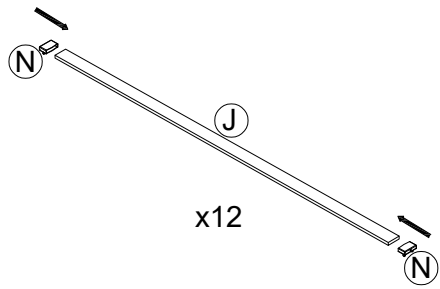

7

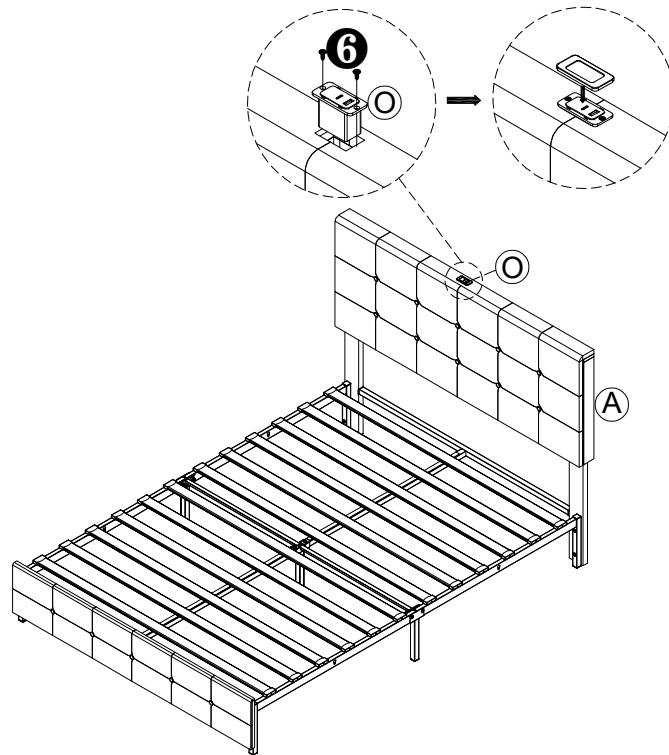

<b>6</b>	 M3*12	2PCS
----------	---	------

8

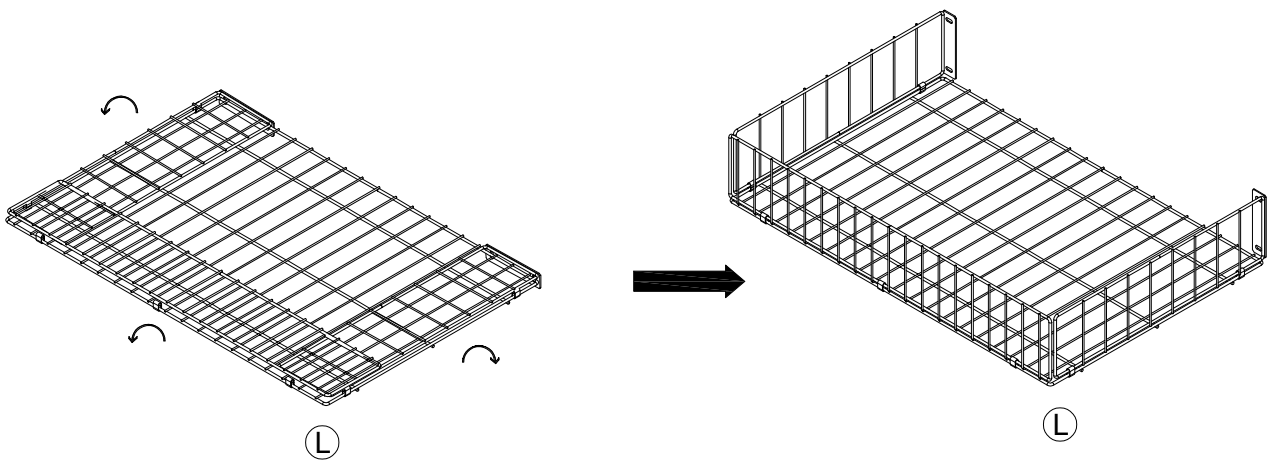

x4

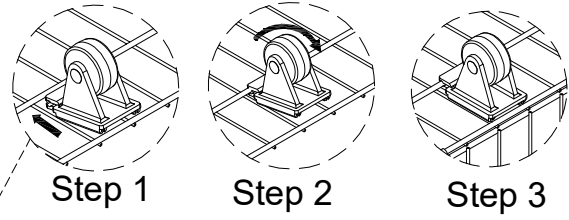
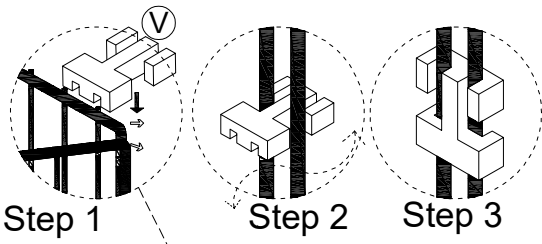

<b>2</b>	 M8*40	8PCS
----------	---	------

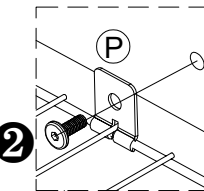
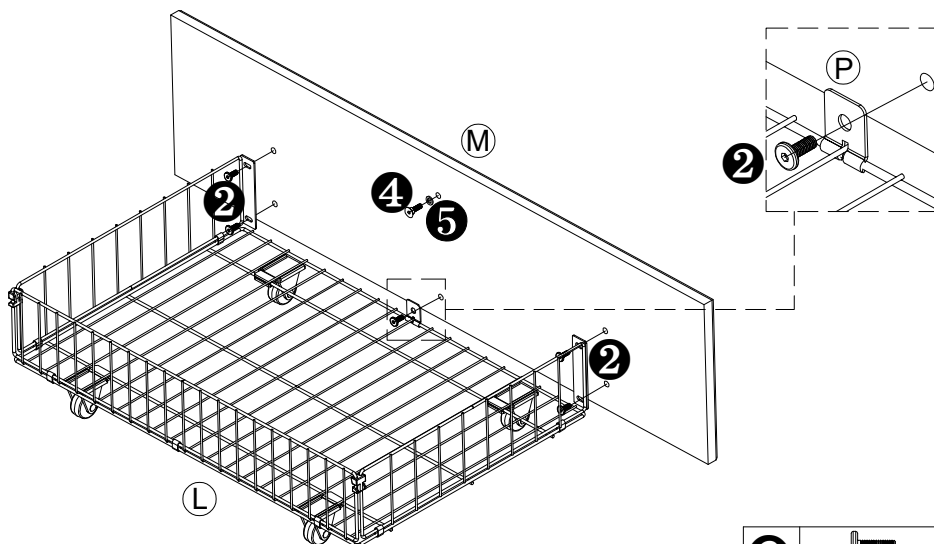
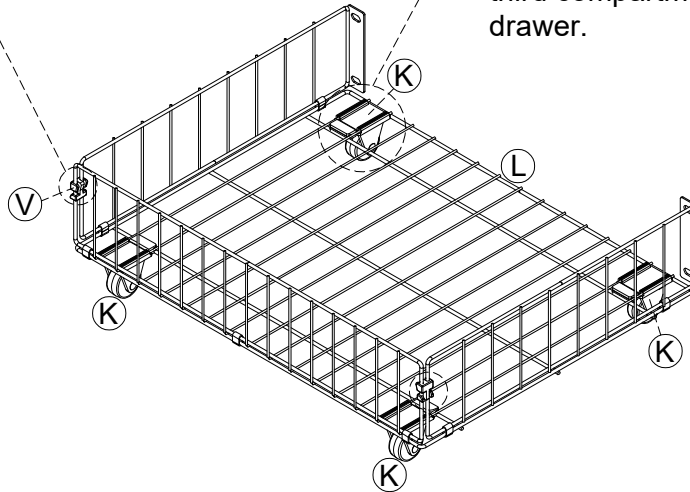

Please assemble the wheel in the second or third compartment of the bottom frame of the drawer.



x4

<b>2</b>	 M6*10	20PCS
<b>4</b>	 M6*20	4PCS
<b>5</b>	 M6	4PCS

11

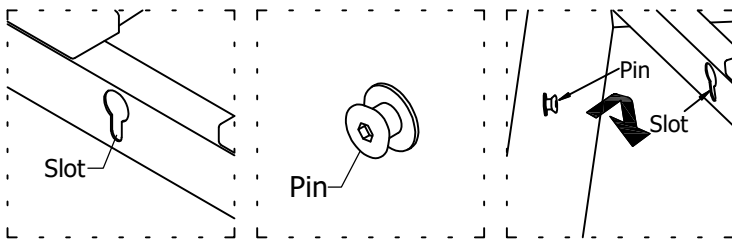

1. Align the pin on the drawer front with the slot in the side rail and push it in.
2. Lock the drawer by gently pushing it down.

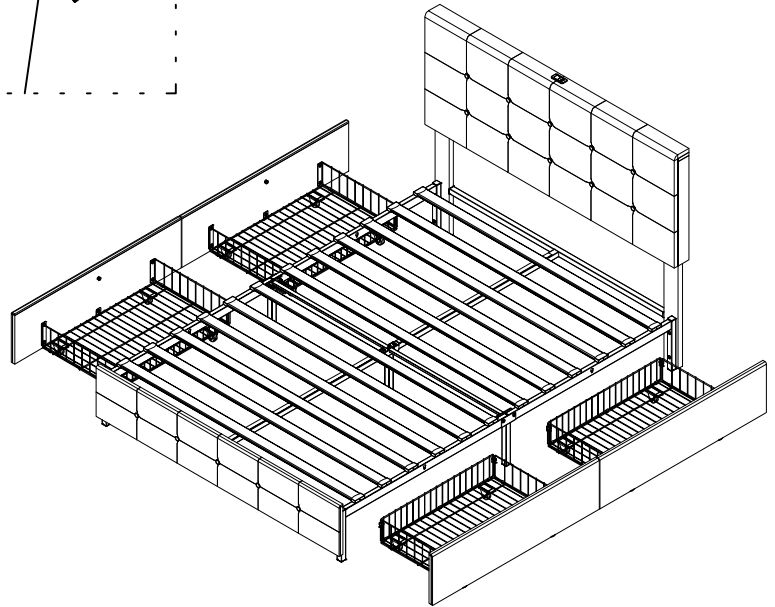

12

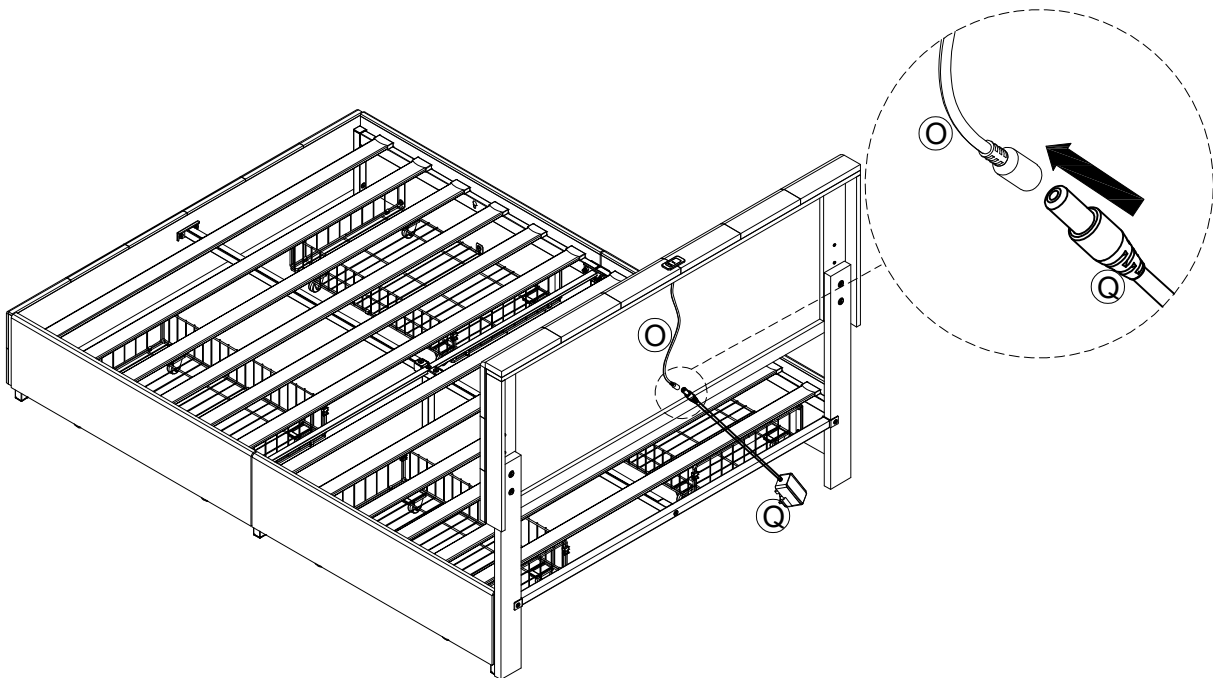

Finish

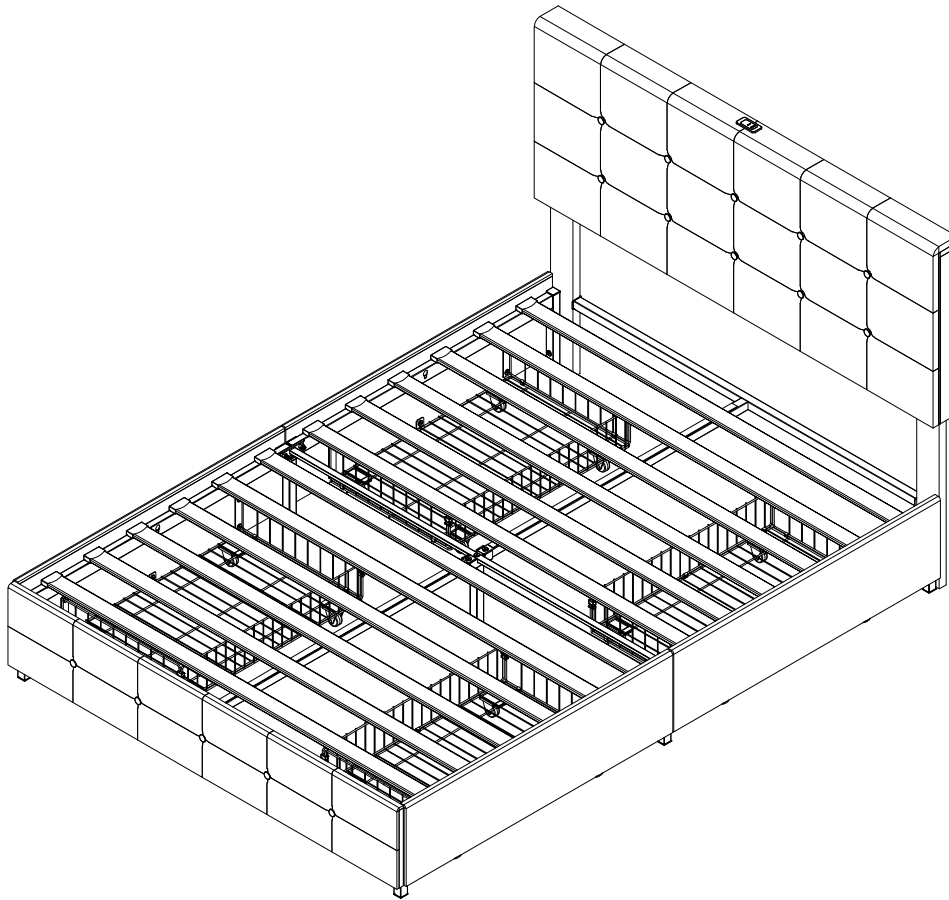

# CERTIFICATE



No. 0P230801.XSWQU14

Certificate's Holder: Xiamen Seebest Wire & Cable Co., Ltd.  
 Floor 1-3, 2 Workshop, No.372 Huanzhu Road, Jimei District,  
 Xiamen City, Fujian 361021 China

Certification ECM Mark



Product: Flexible cables  
 Model(s): (see the following annex)

Verification to: Standard:  
 IEC 60227-5(ed.3):2011  
 related to CE Directive(s):  
 2014/35/EU (Low Voltage)

**Remark:**

The manufacturer has voluntarily decided to submit its documents concerning the above-mentioned product for verification. Ente Certificazione Macchine confirms that the documentation made available and immediately returned to it, as containing sensitive data, meets the essential requirements of the above-mentioned directive/standard. The verification activity carried out exclusively concerned the technical documentation and no verification was carried out on the product. This document cannot replace the EC Declaration of Conformity. This document was issued in accordance with regulation RGVOL01 published on the website of [www.entecerma.it](http://www.entecerma.it) and concerning voluntary certifications with a non-notified procedure.

**Issuance date: 01 August 2023**

**Expiry date: 31 July 2028**

For online check:



Approver  
 Ente Certificazione Macchine  
 Legal Representative  
 Luca Bedonni



# Annex I



No. 0P230801.XSWQU14

## Model(s):

60227 IEC 01 (BV) 450/750V 1.5-25;  
 60227 IEC 02 (RV) 450/750V 1.5-6;  
 60227 IEC 05 (BV) 300/500V 0.5-1;  
 60227 IEC 06 (RV) 300/500V 0.5-1;  
 BV 300/500V 0.75-1;  
 BVR 450/750V 2.5-16;  
 BVVB 300/500V 0.75-10(2-3core);  
 60227 IEC 52 (RVV) 300/300V 0.5-0.75(2-3core);  
 60227 IEC 53 (RVV) 300/500V 0.75-2.5(2-5core);  
 RVV 300/500V 1.5-6(2core), 4(2-5core);  
 RVS 300/300V 0.5-2.5;  
 E(Z)-80/T, TX/PVC 300V 0.051-2.08;  
 E(Z)-105/T, TX/PVC 600V 0.051-2.08;  
 EB(Z)-80/T, TX/PVC 300V 0.051-2.08(2-12 core);  
 EB(Z)-105/T, TX/PVC 600V 0.051-2.08(2-12 core);  
 E(Z)-80/T, TX/PVC/PVC 300V 0.051-2.08(1-10 core);  
 E(Z)-80/T, TX/PVC/P1/PVC 300V 0.051-2.08(1-10 core);  
 E(Z)-80/T, TX/PVC/P(P3)/PVC 300V 0.051-2.08(1-10 core);  
 E(Z)-105/T, TX/PVC/P(P3)/PVC 600V 0.051-2.08(1-10 core);  
 AWM1007, 1015, 1061, 1185, 1569, 1571, 1617, 1672, 2464, 2517, 2586,  
 2725, 2919, 2468, 2651, 2547, 2835, 20276, NISPT-1, NISPT-2, SPT-1, SPT-2,  
 SPT-3, SJT, SVT, ST