

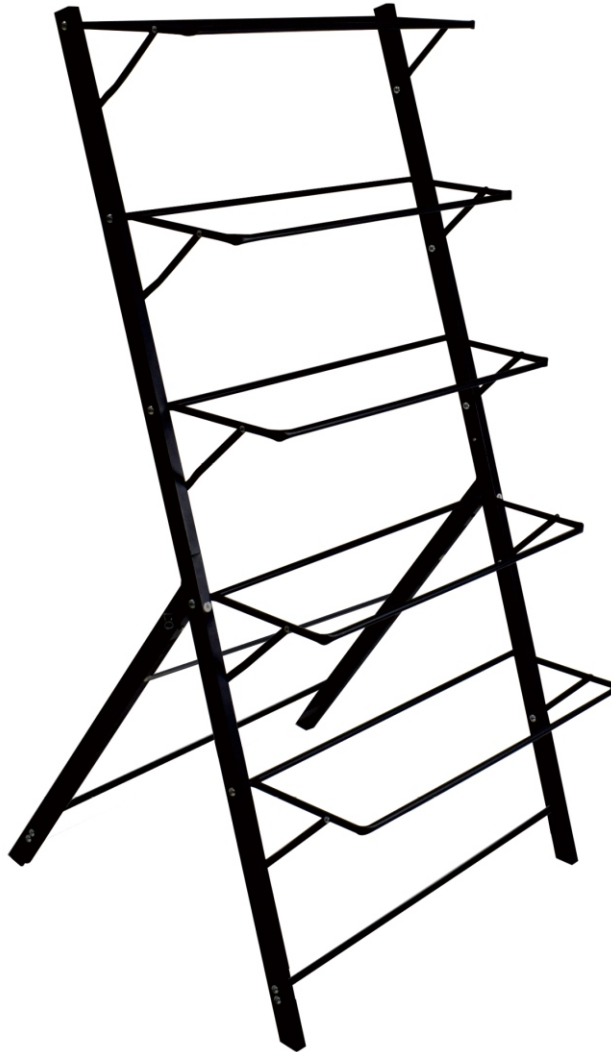

IN231000071V01_GL

845-433V00_845-433V02



EN_IMPORTANT, RETAIN FOR FUTURE REFERENCE: READ CAREFULLY.

FR_IMPORTANT: A LIRE ATTENTIVEMENT ET À CONSERVER POUR CONSULTATION ULTÉRIEURE.

ES_IMPORTANTE, LEA Y GUARDE PARA FUTURAS REFERENCIAS.

PT_IMPORTANTE, REter PARA REFERÊNCIA FUTURA: LEIA ATENTAMENTE.

DE_WICHTIG! SORGFÄLTIG LESEN UND FÜR SPÄTER NACHSCHLAGEN AUFBEWAHREN.

IT_IMPORTANTE! CONSERVARE IL PRESENTE MANUALE PER FUTURO RIFERIMENTO E LEGGERLO ATTENTAMENTE.

PARTS

A x01

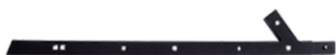

B x01



C x01



D x01



E x02



F x03



G x05



J x05



HARDWARE

2 x16
30mm
+1 (spare)



3 x10
20mm
+1 (spare)



4 x01



EN_ Do not confuse similar screws.
FR_ Ne pas confondre des vis similaires.
ES_ No confunda tornillos similares.
PT_ Não confundir parafusos semelhantes.
DE_ Verwechseln Sie ähnliche Schrauben nicht.
IT_ Non confondere le viti simili.

NOTE

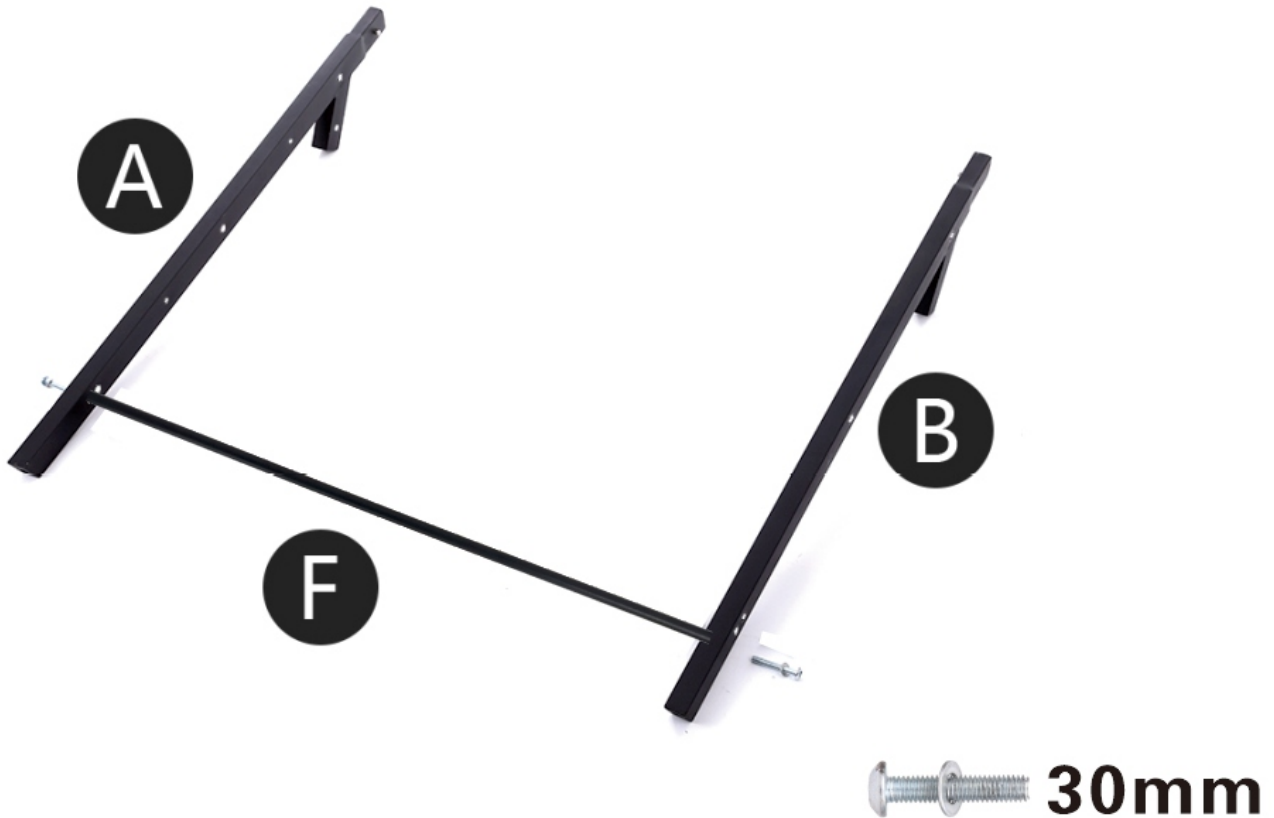

EN_Step 1: Assemble A & B with F.

Direction same as below photo, the clasp spring button on A/B should be inward.

FR_Étape 1 : Assembler A et B avec F.

La direction est la même que sur la photo ci-dessous, le bouton du ressort du fermoir sur A/B doit être tourné vers l'intérieur.

ES_Paso 1: Ensamble A y B con F.

La dirección es la misma que en la foto de abajo, el botón de resorte del cierre en A/B debe estar hacia adentro.

PT_Passo 1: Montar A e B com F.

Direção igual à da fotografia abaixo, o botão de mola do fecho em A/B deve estar para dentro.

DE_Schritt 1: Montieren Sie A und B mit F.

Die Richtung ist dieselbe wie auf dem Foto unten, der Federknopf des Verschlusses an A/B sollte nach innen zeigen.

IT_Fase 1: Assemblare A e B con F.

Come nella foto qui sotto, il pulsante di chiusura di A/B deve essere rivolto verso l'interno.



EN_Step 2: Assemble E with F.

Direction same as below photo, the clasp spring button on E should be inward.

FR_Étape 2 : Assembler E et F.

Direction identique à la photo ci-dessous, le bouton du ressort du fermoir sur E doit être orienté vers l'intérieur.

ES_Paso 2: Ensamble E con F.

La dirección es la misma que en la foto de abajo, el botón de resorte del cierre en E debe estar hacia adentro.

PT_Passo 2: Montar E com F.

Direção igual à da fotografia abaixo, o botão de mola do fecho em E deve ficar para dentro.

DE_Schritt 2: Montieren Sie E mit F.

Die Richtung ist dieselbe wie auf dem Foto unten, der Federknopf des Verschlusses an E sollte nach innen zeigen.

IT_Fase 2: assemblare E con F.

Come nella foto sottostante, il pulsante della molla di chiusura di E deve essere rivolto verso l'interno.

EN_Step 3: Assemble the part of step 1 & 2.

FR_Étape 3 : Assembler les parties des étapes 1 et 2.

ES_Paso 3: Montar la parte de los pasos 1 y 2.

PT_Etapa 3: Montar a parte das etapas 1 e 2.

DE_Schritt 3: Bauen Sie die Teile aus Schritt 1 und 2 zusammen.

IT_Fase 3: assemblare la parte delle fasi 1 e 2.

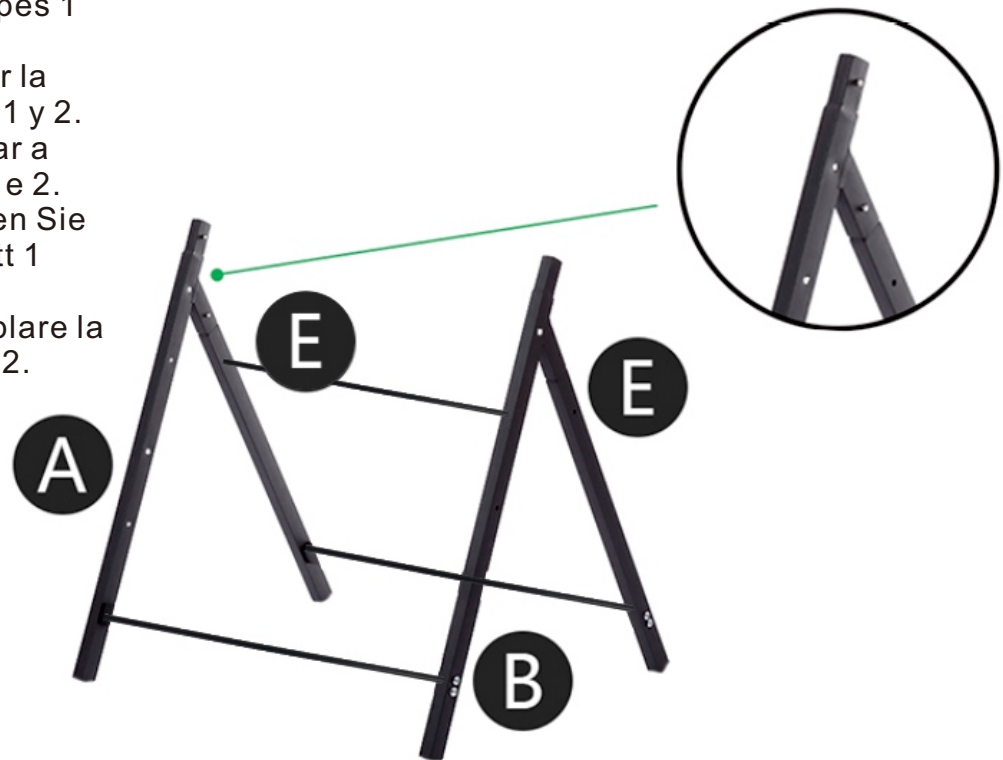

EN_Step 4: Assemble C onto A & D onto B.

The side with more holes is inward

FR_Étape 4 : Assembler C sur A et D sur B.

Le côté avec le plus de trous est vers l'intérieur

ES_Paso 4: Ensamble C en A y D en B.

El lado con más agujeros es el interior

PT_Etapa 4: Montar C em A e D em B.

O lado com mais furos fica para dentro

DE_Schritt 4: Montieren Sie C auf A und D auf B.

Die Seite mit den meisten Löchern ist nach innen gerichtet.

IT_Fase 4: assemblare C su A e D su B.

Il lato con più fori è verso l'interno

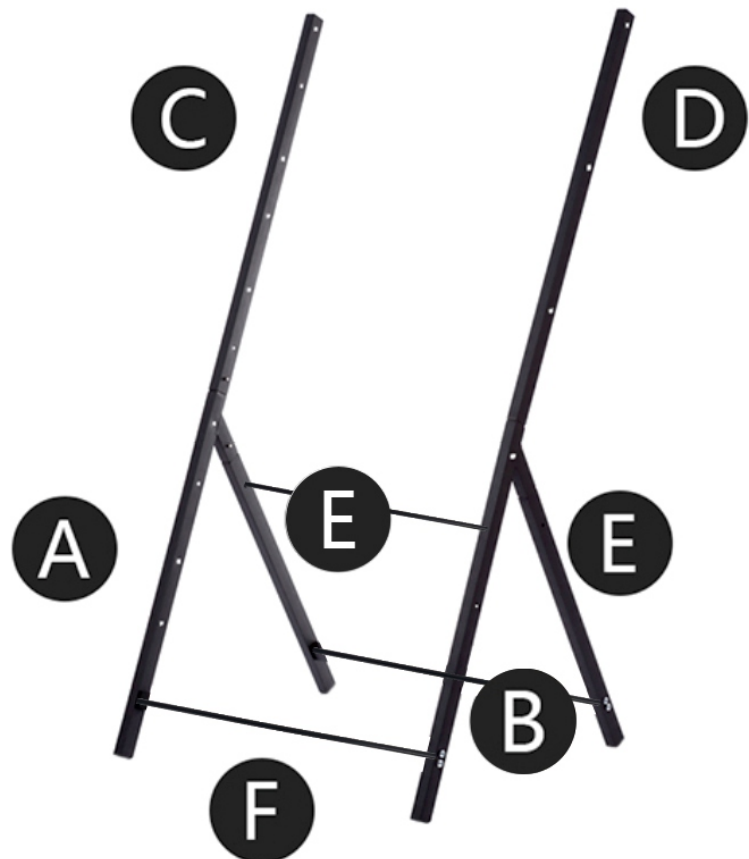

EN_Step 5: Assemble G onto rack.

From the bottom to the top, fix screws first, all parts fix well then screw firmly.

FR_Étape 5 : Assembler G sur le support.

De bas en haut, fixer d'abord les vis, bien fixer toutes les pièces puis visser fermement.

ES_Paso 5: Monte la G en el bastidor.

Desde abajo hacia arriba, fije primero los tornillos, todas las piezas se fijan bien y luego se atornillan firmemente.

PT_Passo 5: Montar o G na prateleira.

De baixo para cima, fixar primeiro os parafusos, todas as peças devem ser bem fixadas e depois aparafusadas com firmeza.

DE_Schritt 5: Montieren Sie G auf dem Gestell.

Von unten nach oben, Schrauben zuerst befestigen, alle Teile gut befestigen, dann festschrauben.

IT_Fase 5: Assemblare G sul rack.

Dal basso verso l'alto, fissare prima le viti, fissare bene tutte le parti e avvitare saldamente.

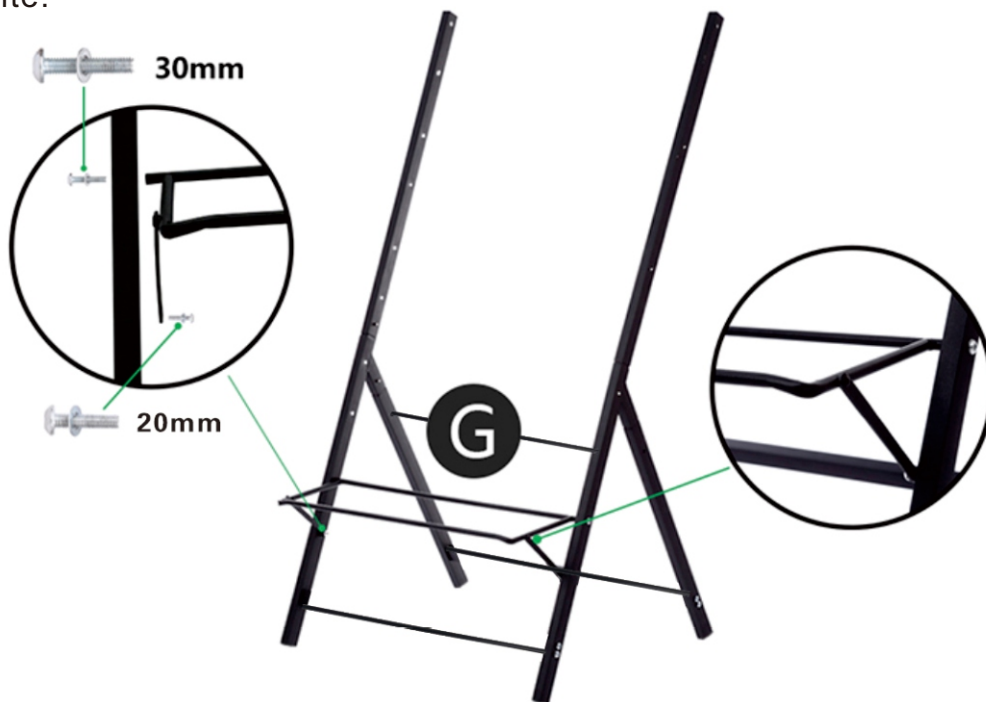

EN_Step 6: Place plastic pots onto rack.

The pot bottom have holes should face forward this can make sure water flow to below pot well.

FR_Étape 6 : Placer les pots en plastique sur le support.

Les trous au fond des pots doivent être orientés vers l'avant, ce qui permet de s'assurer que l'eau s'écoule bien sous le pot.

ES_Paso 6: Coloque las macetas de plástico en la rejilla.

El fondo de la maceta tiene agujeros que deben mirar hacia adelante para asegurar que el agua fluya bien por debajo de la maceta.

PT_Passo 6: Colocar os vasos de plástico no suporte.

O fundo do vaso tem orifícios que devem estar virados para a frente, para garantir que a água flui bem para baixo do vaso.

DE_Schritt 6: Stellen Sie die Kunststofftöpfe auf das Gestell.

Der Topfboden sollte Löcher haben, die nach vorne zeigen, damit das Wasser gut unter den Topf fließen kann.

IT_Fase 6: collocare i vasi di plastica sulla rastrelliera.

I fori sul fondo dei vasi devono essere rivolti in avanti, in modo da garantire un buon flusso d'acqua al di sotto del vaso.

If you have any questions, please contact our customer care center, Our contact details are below:

US

 001-877-644-9366

 customerservice@aosom.com

Imported by Aosom LLC
27150 SW Kinsman Rd Wilsonville, OR 97070 USA
MADE IN CHINA

If you have any questions, please contact our customer care center, Our contact details are below:

CA

 416-792-6088

 customerservice@aosom.ca

Imported by Aosom Canada Inc.
7270 Woodbine Avenue, Unit 307, Markham,
Ontario Canada L3R 4B9
MADE IN CHINA

Si vous avez la moindre question, veuillez contacter notre centre d'assistance à la clientèle, Nos coordonnées sont les suivantes:

 416-792-6088

 customerservice@aosom.ca

Importé par Aosom Canada Inc.
7270 Woodbine Avenue, unité 307,
Markham, Ontario Canada L3R 4B9
FABRIQUÉ EN CHINE

If you have any questions, please contact our customer care center, Our contact details are below:

UK

 0044-800-240-4004

 enquiries@mhstar.co.uk

IMPORTER ADDRESS:
MH STAR UK LTD
Unit 27, Perivale Park,
Horsenden lane South
Perivale, UB6 7RH
MADE IN CHINA

Si vous avez la moindre question, veuillez contacter notre centre d'assistance à la clientèle, Nos coordonnées sont les suivantes:

FR

 0033-1-84166106

 aosom@mhfrance.fr

Importé par/Fabricant/REP:
MH FRANCE
2 Rue Maurice Hartmann
92130 Issy Les Moulineaux
France
FABRIQUÉ EN CHINE

Wenn Sie Fragen haben, wenden Sie sich bitte an unser Kundendienstzentrum, Unsere Kontaktdaten stehen unten:

DE

 0049-0(40)-87408465

 service@aosom.de

ADRESSE DES IMPORTEURE/Hersteller/REP:
MH Handel GmbH
Wendenstraße 309
D-20537 Hamburg
Germany
IN CHINA HERGESTELLT

In caso di dubbio, si prega di contattare il nostro centro assistenza clienti, I nostri dettagli di contatto sono di seguito:

IT

 0039-0249471447

 clienti@aosom.it

IMPORTATO DA/Produttore/REP:
AOSOM Italy srl
Centro Direzionale Milanofiori
Strada 1 Palazzo F1
20057 Assago (MI)
P.I.: 08567220960
FATTO IN CINA

Si tiene alguna pregunta, comuníquese con nuestro Centro de Atención al Cliente, Nuestros datos de contacto son los siguientes:

ES

 0034-931294512

 atencioncliente@aosom.es

IMPORTADOR/Fabricante/REP:
SPANISH AOSOM, S.L.
C/ROC GROS, N°15.08550, ELS HOSTALETES DE
BALENYÀ, SPAIN.
B66295775
HECHO EN CHINA

Se tiver alguma dúvida, por favor contacte o nosso Centro de Atendimento ao Cliente, Os nossos dados de contacto são os seguintes:

 0034-931294512

 info@aosom.pt.

IMPORTADOR/Fabricante/REP:
SPANISH AOSOM, S.L.
C.ROC GROS N.15, 08550. ELS HOSTALETES DE
BALENYÀ
FEITO NA CHINA



FR

**DONNEZ
OU
RECYCLEZ**



ASSOCIATION

OU



LIVRAISON

OU



DÉCHÈTERIE

Adresses sur quefairedemesdechets.fr