

HOMCOM

IN250600246V01_GL

83B-327V71

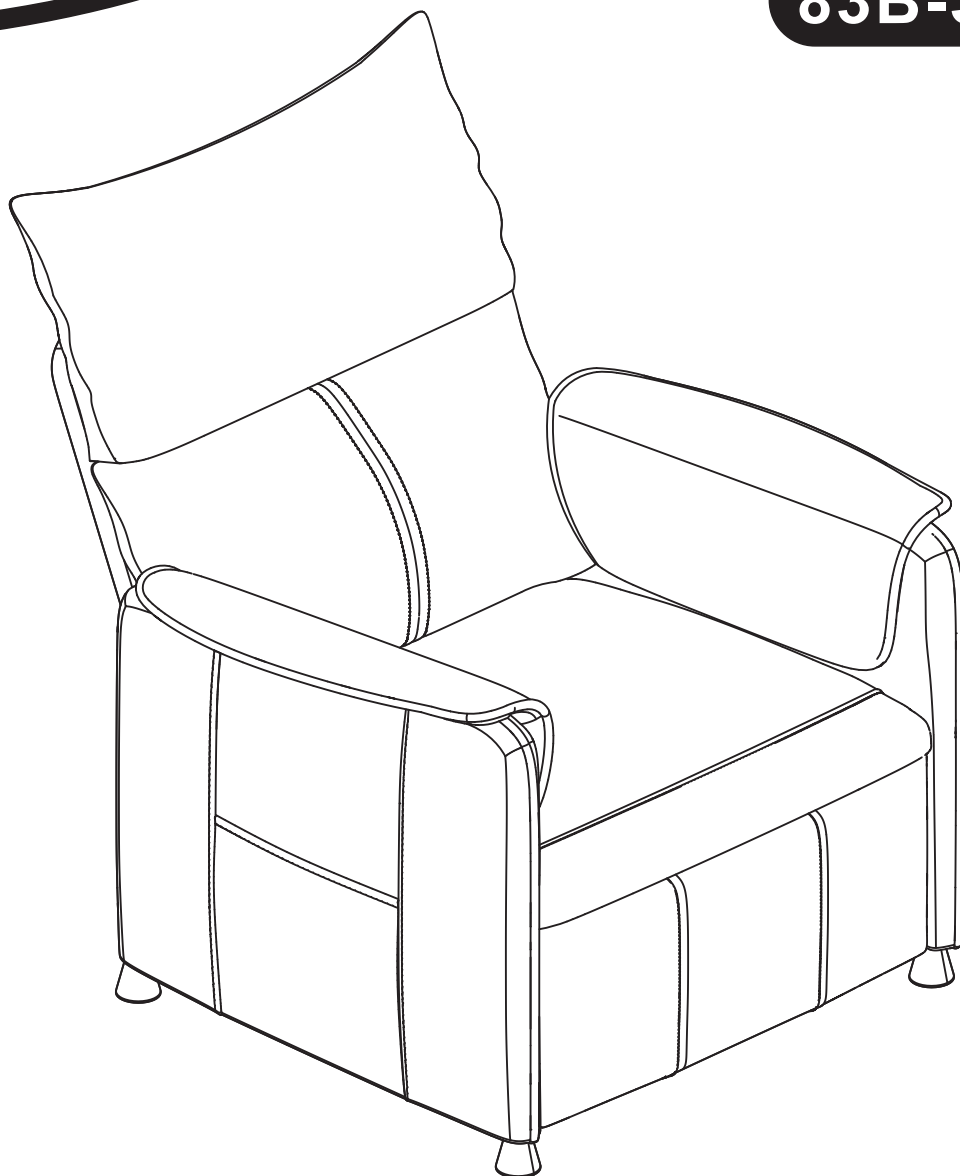

CE

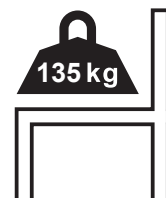
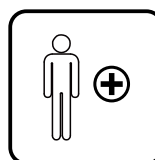
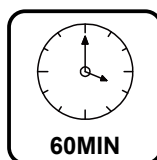

EN_IMPORTANT, RETAIN FOR FUTURE REFERENCE: READ CAREFULLY.

FR_IMPORTANT: A LIRE ATTENTIVEMENT ET A CONSERVER POUR VOUS Y REFRERER ULTERIEUREMENT

ES_IMPORTANTE, LEA DETENIDAMENTE Y GUARDE PARA FUTURAS REFERENCIAS.

PT_IMPORTANTE, GARDE PARA FUTURA REFERÊNCIA, LEIA ATENTAMENTE.

DE_WICHTIG! SORFGFÄLTIG LESEN UND FÜR SPÄTERES NACHSCHLAGEN AUFBEWAHREN.

IT_IMPORTANTE, LEGGERE E CONSERVARE QUESTO MANUALE D'ISTRUZIONE PER UN USO FUTURO.

THE SOFA IS TIDIED UP BEFORE USE

Before

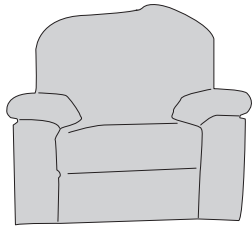

After

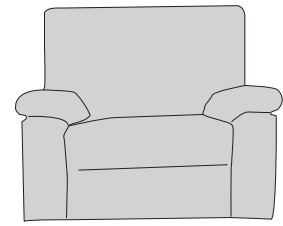

①



②



③

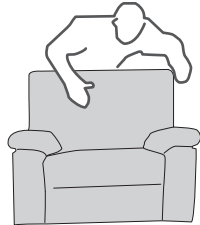

④

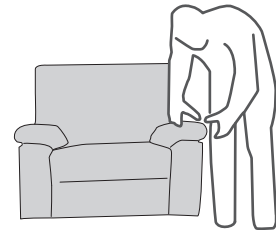

ATTENTION

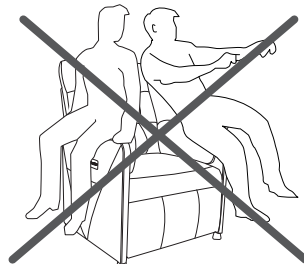
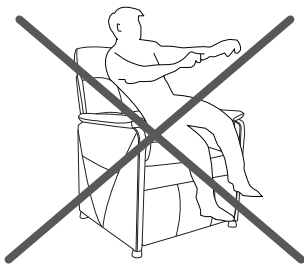
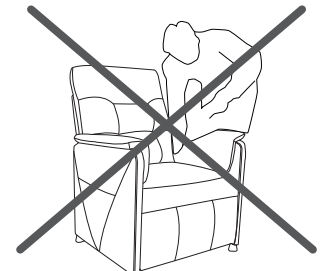
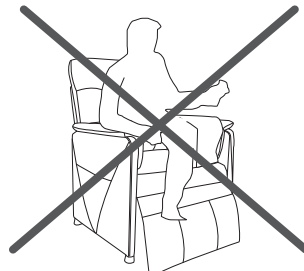
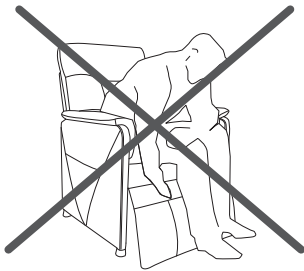

IMPORTANT, RETAIN FOR FUTURE REFERENCE: READ CAREFULLY.

Only for domestic use

Instructions for use:

- *Put the chair stably on a flat floor.
- *Stay away from open flames.
- *Avoid the overload at the chair.

Precautions before assembly:

- *Prepare a clean and dry mounting area.
- *Verify that the product is not damaged.
- *Check that none of the pieces are missing.

Maintenance:

- *Clean with a soft fabric.
- *Check the seating regularly.

Storage conditions:

- *The fabric should be stored completely dry, in a clean and dry place to avoid the risks of mold.

Beware of crushing and cutting hazards during assembly.

The manufacturer declines all responsibility in case of damages due to a bad installation or withering.

Warning! Only trained personnel may replace or repair components for height adjustment of seating furniture with energy storage.

If the product has electrical parts:

This appliance can be used by children aged from 8 years and above and persons with reduced physical, sensory or mental capabilities or lack of experience and knowledge if they have been given supervision or instruction concerning use of the appliance in a safe way and understand the hazards involved.

Children shall not play with the appliance.

Cleaning and user maintenance shall not be made by children without supervision.

The appliance is only to be used with the power supply unit provided with the appliance.

The external flexible cable or cord of this transformer cannot be replaced; if the cord is damaged, the transformer shall be scrapped.

If The appliance has a heated surface. Persons insensitive to heat must be careful when using the appliance.



The power supply unit shall not be used, if pins of the plug part are damaged.

IMPORTANT: A LIRE ATTENTIVEMENT ET À CONSERVER POUR CONSULTATION ULTÉRIEURE.

Réservé à un usage domestique

Conseils :

- *Placez la chaise sur un sol plat et sec afin qu'elle soit stable
- *Placer à l'écart des flammes ou de sources de chaleur
- *Ne pas dépasser la charge maximale autorisée

Précautions avant l'assemblage :

- *Préparez une zone de montage propre et sèche
- *Vérifiez que le produit n'est pas endommagé
- *Vérifiez qu'aucune des pièces de ne manque

Recommandations d'entretien :

- *Veuillez utiliser un chiffon doux pour essuyer la chaise
- *Vérifiez régulièrement la structure du produit

Conditions de stockage:

- *Veuillez stocker le produit dans un environnement propre et sec pour éviter tout risque de moisissure.

Veillez faire attention à ne pas vous blesser lors de l'assemblage du produit. Le fabricant n'est pas responsable des dommages causés par une mau-vaie installation.

Attention! Le remplacement et la réparation des pièces pour le réglage de la hauteur du fauteuil avec accumulateurs d'énergie ne doivent être effectués que par du personnel qualifié.

Si le produit comporte des pièces électriques :

Cet appareil peut être utilisé par des enfants à partir de 8 ans et plus et par des personnes ayant des capacités physiques, sensorielles ou mentales réduites ou un manque d'expérience et de connaissances à condition qu'elles aient reçu une supervision ou des instructions concernant l'utilisation de l'appareil en toute sécurité et qu'elles comprennent les dangers encourus.

Les enfants ne doivent pas jouer avec l'appareil.

Le nettoyage et l'entretien par l'utilisateur ne doivent pas être effectués par des enfants sans surveillance.

L'appareil doit être utilisé uniquement avec l'alimentation fournie avec l'appareil.

Le câble souple externe de ce transformateur ne peut pas être remplacé; en cas d'endommagement du cordon, le transformateur doit être mis au rebut.

Si L'appareil comporte une surface chaude. Les personnes insensibles à la chaleur doivent être prudentes lorsqu'elles utilisent l'appareil.



Le bloc d'alimentation ne doit pas être utilisé si les broches de la partie fiche sont endommagées.

IMPORTANTE: LEA Y GUARDE PARA FUTURAS REFERENCIAS.

Producto para uso doméstico

Consejos de uso:

- *Coloque el producto sobre un suelo plano de forma estable.
- *Manténgase alejado de fuentes de calor y llamas.
- *Evite la sobrecarga de los anclajes del producto.

Precauciones antes del montaje:

- * Prepare la zona de montaje. Asegúrese de que esté limpia y seca.
- * Asegúrese de que el producto está en buen estado.
- * Verifique que no falta ninguna de las piezas.

Mantenimiento:

- *Limpie el producto con la ayuda de un paño suave.
- *Inspeccione el producto de forma regular a fin de detectar posibles daños o desperfectos que puedan afectar a su uso.

Condiciones de almacenaje:

- *A fin de evitar la aparición de moho, los tejidos se deben de guardar totalmente secos y en un lugar limpio y sin humedad.

Atención:

Riesgo de pinzamientos o cortes durante el montaje.

El fabricante declina toda responsabilidad en caso de deterioro debido a una mala instalación o por causar meteorológicas.

¡Advertencia! La sustitución y la reparación de los componentes para la regulación de la altura de la silla con acumuladores de energía deben ser efectuados solo por personal cualificado.

Si el producto tiene partes eléctricas:

Este aparato puede ser utilizado por niños a partir de 8 años y personas con capacidades físicas, sensoriales o mentales reducidas o con falta de experiencia y conocimientos si han recibido supervisión o instrucciones sobre el uso del aparato de forma segura y comprenden los peligros que conlleva.

Los niños no deben jugar con el aparato.

Los niños no deben limpiar ni realizar tareas de mantenimiento sin supervisión.

El aparato sólo debe utilizarse con la fuente de alimentación suministrada con el mismo.

El cable flexible externo o cordón de este transformador no puede ser reemplazado; si el cordón está dañado, el transformador debe ser desechado.

Si el aparato tiene una superficie caliente. Las personas insensibles al calor deben tener cuidado al utilizar el aparato.



No utilice la fuente de alimentación si las clavijas del enchufe están dañadas.

IMPORTANTE, RETER PARAREFERÊNCIA FUTURA: LEIA ATENTAMENTE.

Produto para uso doméstico

Conselhos de uso:

- * Coloque o produto sobre um solo plano e estável.
- * Mantenha-o afastado de fontes de calor e chamas.
- * Evite a sobre carga das fixações do produto.

Precauções antes da montagem:

- * Prepare a zona de montagem. Certifique-se de que esteja limpa e seca.
- * Certifique-se que o produto esteja em bom estado.
- * Verifique que não falte nenhuma das peças.

Manutenção:

- * Limpar o produto com a ajuda de um pano suave.
- * Inspeccionar o produto de forma regular a fim de detectar possíveis defeitos que possa afetar seu uso.

Condições de armazenamento:

- * A fim de evitar a aparecimento de mofo, os tecidos se devem guardar totalmente secos e em um lugar limpo e sem umidade.

Atenção:

Risco de cortes durante a montagem. O fabricante declina toda responsabilidade no caso de deterioração devido uma má instalação ou por causas meteorológicas.

Aviso! A substituição ou reparação de componentes para a regulação em altura de mobiliário para sentar com acumulador de energia só pode ser efectuada por pessoal qualificado.

Se o produto tiver partes eléctricas:

Este aparelho pode ser utilizado por crianças a partir dos 8 anos de idade e por pessoas com capacidades físicas, sensoriais ou mentais reduzidas ou com falta de experiência e conhecimentos, desde que tenham recebido supervisão ou instruções sobre a utilização do aparelho de forma segura e compreendam os perigos envolvidos.

As crianças não devem brincar com o aparelho.

A limpeza e a manutenção pelo utilizador não devem ser efectuadas por crianças sem supervisão.

O aparelho só deve ser utilizado com a fonte de alimentação fornecida com o aparelho.

O cabo flexível externo ou o cabo deste transformador não podem ser substituídos; se o cabo estiver danificado, o transformador deve ser eliminado.

Se O aparelho tem uma superfície aquecida. As pessoas insensíveis ao calor devem ter cuidado ao utilizar o aparelho.

A fonte de alimentação não deve ser utilizada se os pinos da ficha estiverem danificados.



WICHTIG! SORGFÄLTIG LESEN UND ZUM SPÄTEREN NACHSCHLAGEN AUFBEWAHREN.

Ausschließlich für den häuslichen Gebrauch bestimmt

Nutzungshinweise:

- *Bitte stellen Sie den Stuhl stabil auf eine ebene Fläche.
- *Von offenen Feuerquellen fernhalten.
- *Vermeiden Sie eine Überlastung des Stuhls.

Vorsichtsmaßnahmen vor der Montage:

- *Bitte bereiten Sie einen sauberen und trockenen Montagebereich vor.
- *Stellen Sie sicher, dass das Produkt nicht beschädigt ist.
- *Vergewissern Sie sich, dass kein Zubehörteil fehlt.

Instandhaltung:

- *Bitte reinigen Sie den Stuhl nur mit einem weichen Tuch.
- *Überprüfen Sie den Stuhl regelmäßig.

Lagerung:

- *Der Stoff sollte an einem völlig trockenen und sauberen Ort aufbewahrt werden, um Schimmel zu vermeiden.

Vorsicht vor Quetsch- und Schnittgefahr bei der Montage.
Der Hersteller lehnt jegliche Haftung für Schäden ab, die aufgrund unsachgemäßer Montage oder Witterungseinflüsse verursacht werden.
Warnung! Der Austausch und die Reparatur von Zubehörteilen zur Einstellung der Stuhlhöhe darf nur von qualifiziertem Fachpersonal durchgeführt werden.

Wenn das Produkt elektrische Teile enthält:

Dieses Gerät kann von Kindern ab 8 Jahren und darüber sowie von Personen mit verringerten physischen, sensorischen oder mentalen Fähigkeiten oder Mangel an Erfahrung und Wissen benutzt werden, wenn sie beaufsichtigt oder bezüglich des sicheren Gebrauchs des Gerätes unterwiesen wurden und die daraus resultierenden Gefahren verstehen. Kinder dürfen nicht mit dem Gerät spielen.

Reinigung und Benutzer-Wartung dürfen nicht von Kindern ohne Beaufsichtigung durchgeführt werden.

Das Gerät ist nur mit dem mitgelieferten Netzteil zu benutzen.

Das externe flexible Kabel dieses Transformators kann nicht ersetzt werden; Wenn das Kabel beschädigt ist, muss der Transformator verschrottet werden.

Wenn Das Gerät hat eine beheizte Oberfläche. Hitzeunempfindliche



Personen müssen bei der Verwendung des Geräts vorsichtig sein.
Das Netzteil darf nicht verwendet werden, wenn die Stifte des Steckerteils beschädigt sind.

IMPORTANTE! CONSERVARE IL PRESENTE MANUALE PER FUTURO RIFERIMENTO E LEGGERLO ATTENTAMENTE.

Solo per uso domestico

Istruzioni per l'uso:

- *Posizionare la sedia in maniera stabile su un pavimento in piano.
- *Tenere lontano dalle fiamme vive.
- *Evitare di sovraccaricare la sedia.

Precauzioni prima del montaggio:

- *Preparare un'area di montaggio sgombra e asciutta.
- *Verificare che il prodotto non sia danneggiato.
- *Verificare che non manchi nessun pezzo.

Manutenzione:

- *Pulire con un tessuto morbido.
- *Controllare regolarmente il sedile.

Condizioni di stoccaggio:

- *Il tessuto deve essere conservato completamente asciutto, in un luogo pulito e asciutto per evitare la formazione di muffa.

Fare attenzione al rischio di schiacciamento e di taglio durante le fasi di montaggio.

Il produttore declina ogni responsabilità in caso di danni dovuti ad un'installazione incorretta o alle intemperie.

Avvertenza! La sostituzione e la riparazione di componenti per la regolazione dell'altezza della sedia con un sistema di propulsione va eseguita solo da personale qualificato.

Se il prodotto ha parti elettriche:

Questo apparecchio può essere utilizzato da bambini di età pari o superiore a 8 anni e da persone con ridotte capacità fisiche, sensoriali o mentali o con mancanza di esperienza e conoscenza, a condizione che abbiano ricevuto supervisione o istruzioni sull'uso dell'apparecchio in modo sicuro e che comprendano i rischi connessi.

I bambini non devono giocare con l'apparecchio.

La pulizia e la manutenzione da parte dell'utente non devono essere eseguite da bambini senza supervisione.

L'apparecchio deve essere utilizzato solo con l'alimentatore fornito in dotazione.

Il cavo flessibile esterno o il cavo di questo trasformatore non possono essere sostituiti; se il cavo è danneggiato, il trasformatore deve essere rottamato.

Se l'apparecchio ha una superficie riscaldata. Le persone insensibili al calore devono prestare attenzione quando utilizzano l'apparecchio.



L'alimentatore non deve essere utilizzato se gli spinotti della spina sono danneggiati.

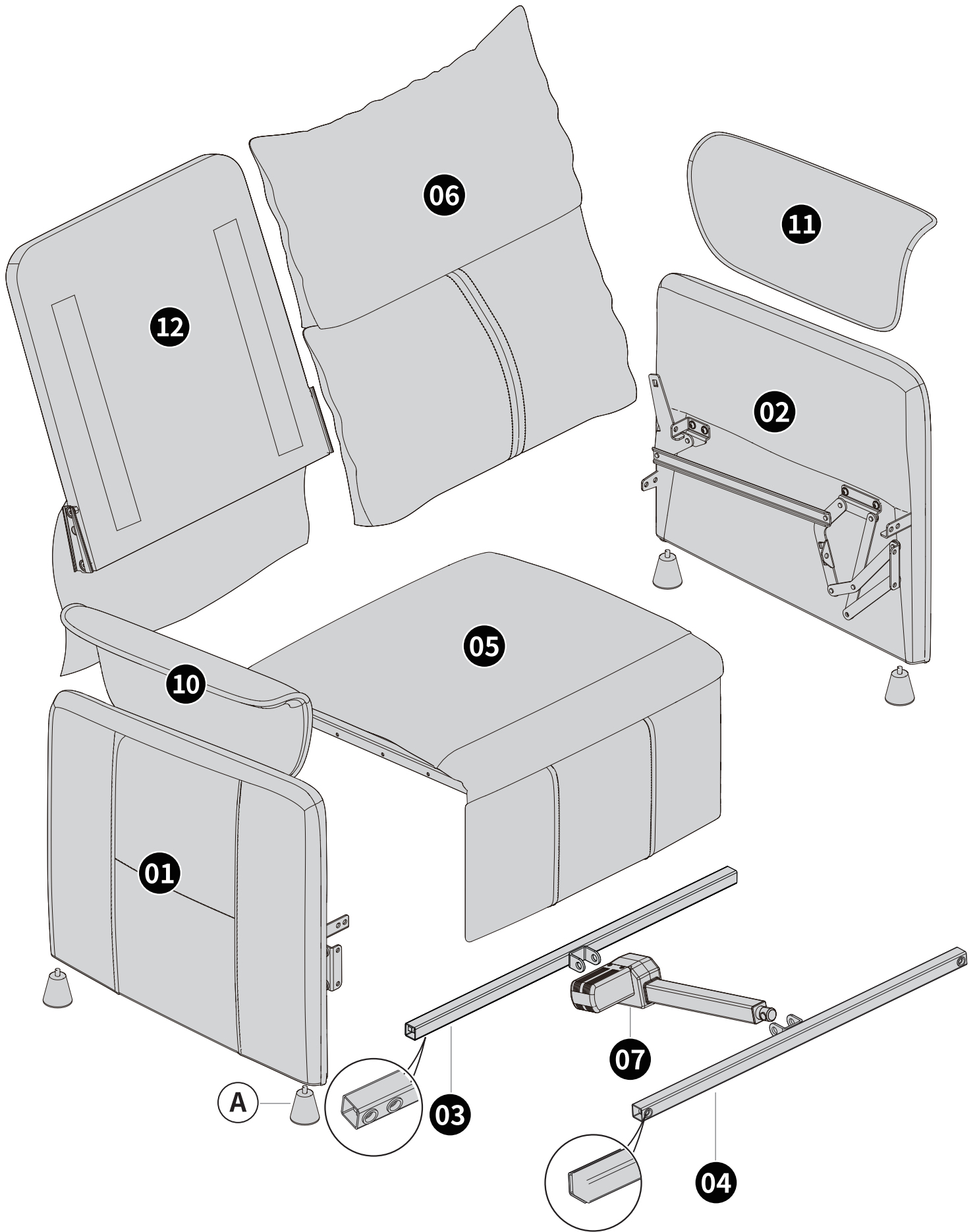

PACKING DETAILS: TOTAL 2 BOXES

BOX-1/2

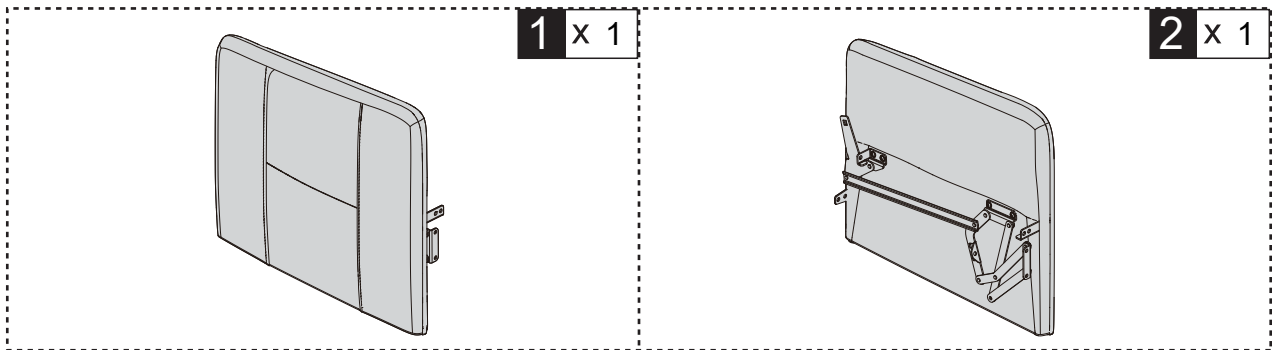

BOX-2/2

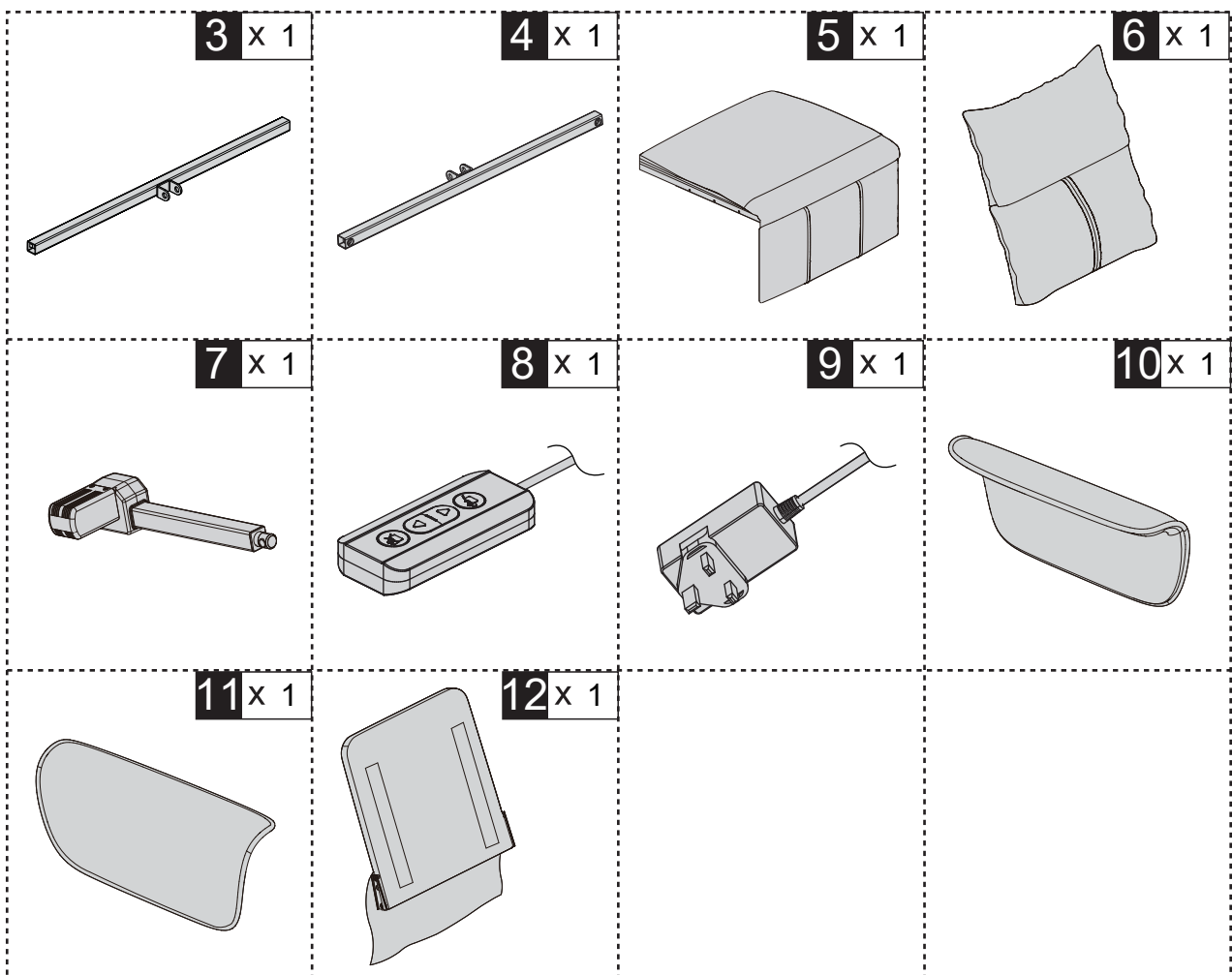

PACKING SCREWS

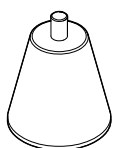

(A) x 4



M8 x 20mm

(B) x 12

+2 (spare)



M6 x 15mm

(C) x 4

+1 (spare)

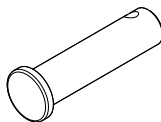

(D) x 2

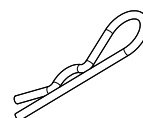

(E) x 2

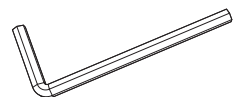

3/16" (5mm)

(F) x 1

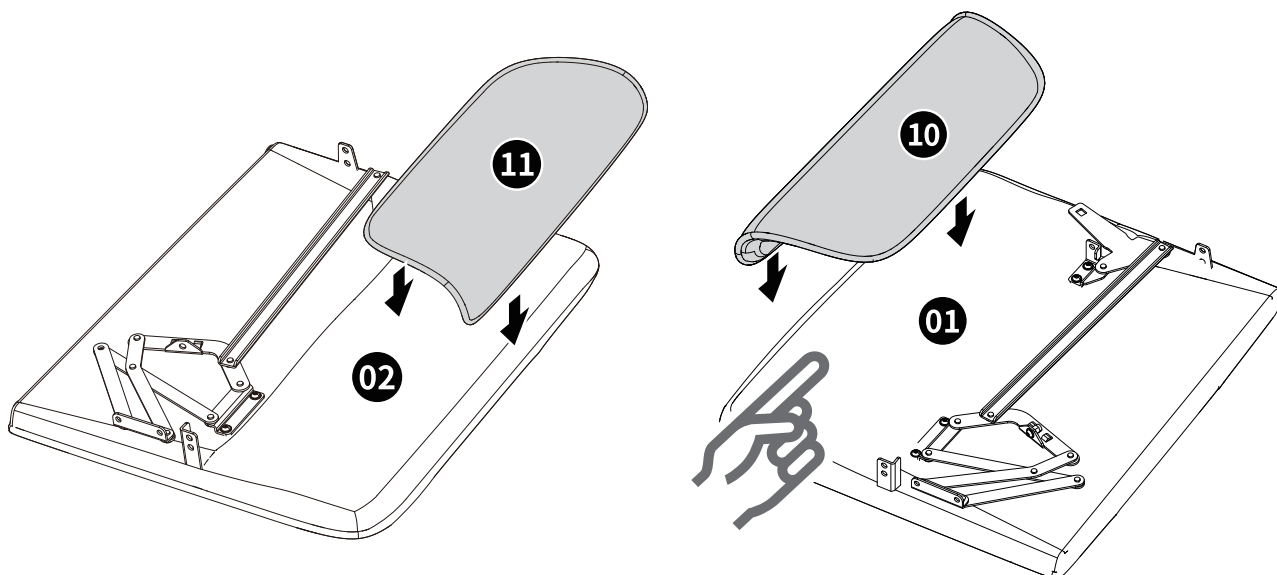

TIP: Zip up to connect the two parts.

CONSEIL : Fermez la fermeture éclair pour connecter les deux parties.

TIPP: Ziehen Sie den Reißverschluss zu, um die zwei Teile zu verbinden.

CONSEJO: Suba la cremallera para conectar las dos partes.

DICA: Feche o zíper para conectar as duas partes.

CONSIGLIO: Chiudete la cerniera per collegare le due parti.



(A) x 4

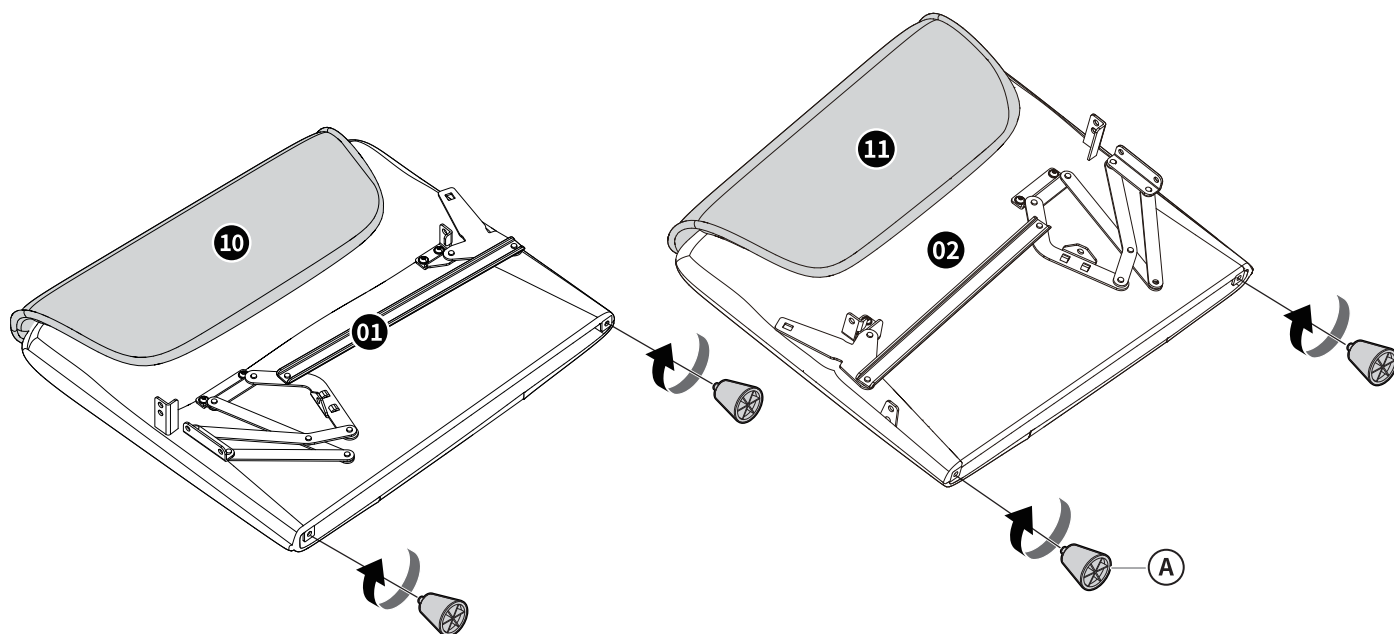

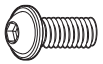

M8 x 20mm



3/16" (5mm)

B x 6

F x 1

Note: Do not tighten bolts fully until step 6 is completed!

Remarque : Ne vissez pas complètement les boulons avant que l'étape 5 ne soit terminée !

Hinweis: Ziehen Sie die Schrauben nicht vollständig fest, bevor Schritt 5 abgeschlossen ist!

Nota: ¡No apriete completamente los pernos hasta que el paso 5 esté completado!

Nota: Não aperte completamente os parafusos até que a etapa 5 esteja concluída!

Nota: Non stringere completamente i bulloni finché il passaggio 5 non è completato!

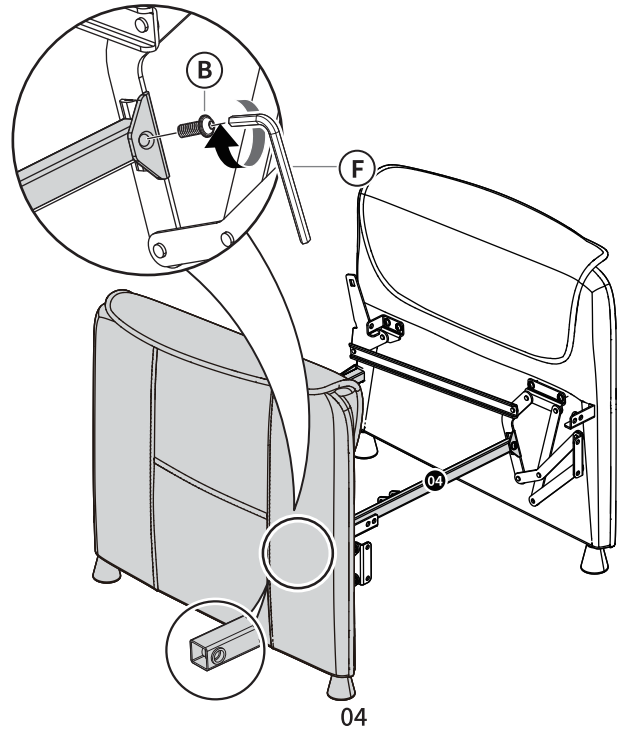
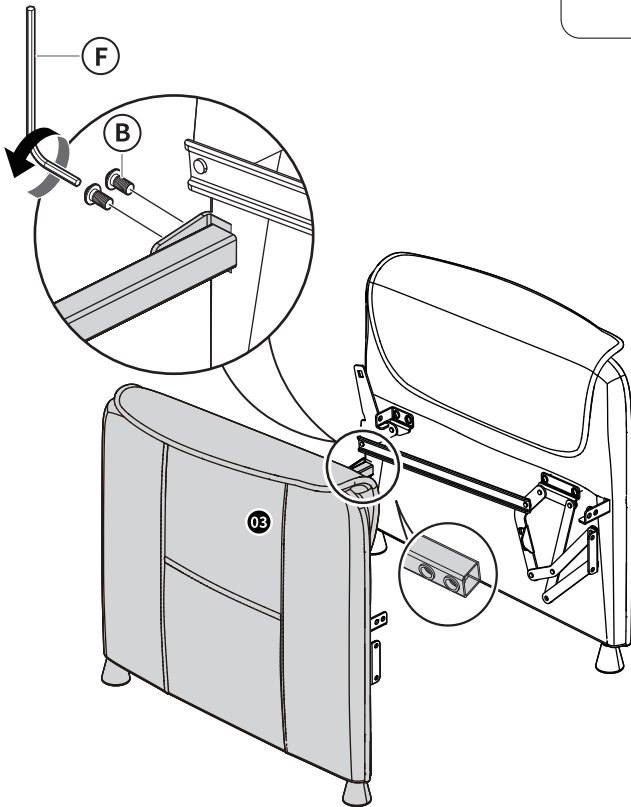

Note: Do not tighten bolts fully until step 6 is completed!

Remarque : Ne vissez pas complètement les boulons avant que l'étape 5 ne soit terminée !

Hinweis: Ziehen Sie die Schrauben nicht vollständig fest, bevor Schritt 5 abgeschlossen ist!

Nota: ¡No apriete completamente los pernos hasta que el paso 5 esté completado!

Nota: Não aperte completamente os parafusos até que a etapa 5 esteja concluída!

Nota: Non stringere completamente i bulloni finché il passaggio 5 non è completato!

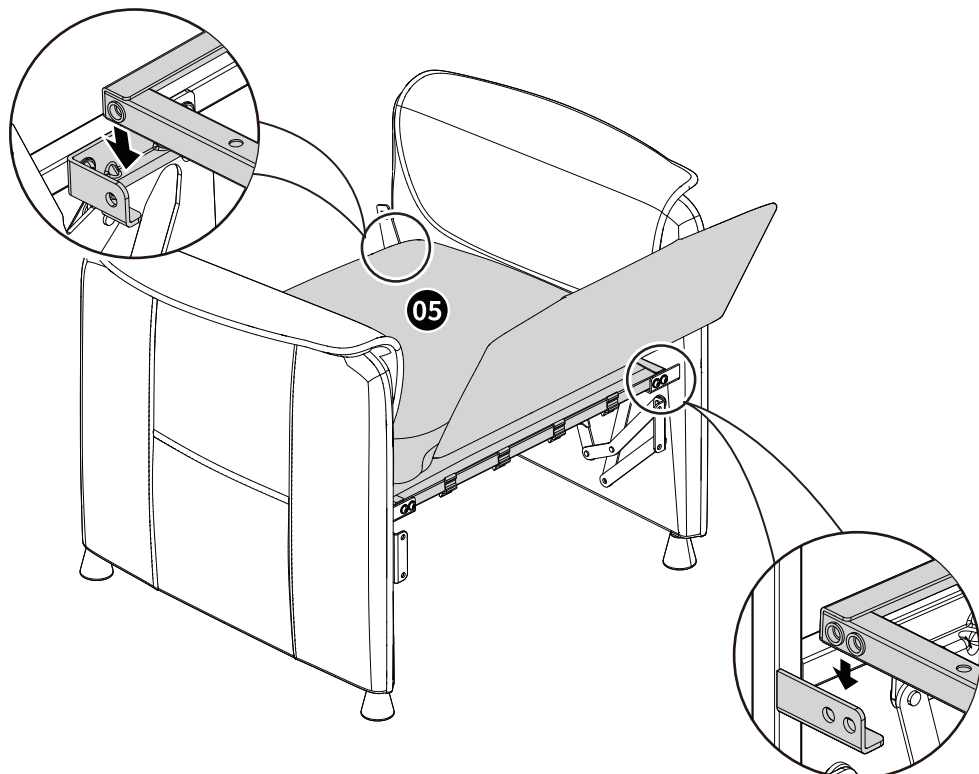

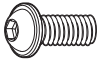

M8 x 20mm

(B) x 4

3/16" (5mm)

(F) x 1

Note: Do not tighten bolts fully until step 6 is completed!

Remarque : Ne vissez pas complètement les boulons avant que l'étape 5 ne soit terminée !

Hinweis: Ziehen Sie die Schrauben nicht vollständig fest, bevor Schritt 5 abgeschlossen ist!

Nota: ¡No apriete completamente los pernos hasta que el paso 5 esté completado!

Nota: Não aperte completamente os parafusos até que a etapa 5 esteja concluída!

Nota: Non stringere completamente i bulloni finché il passaggio 5 non è completato!

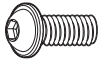
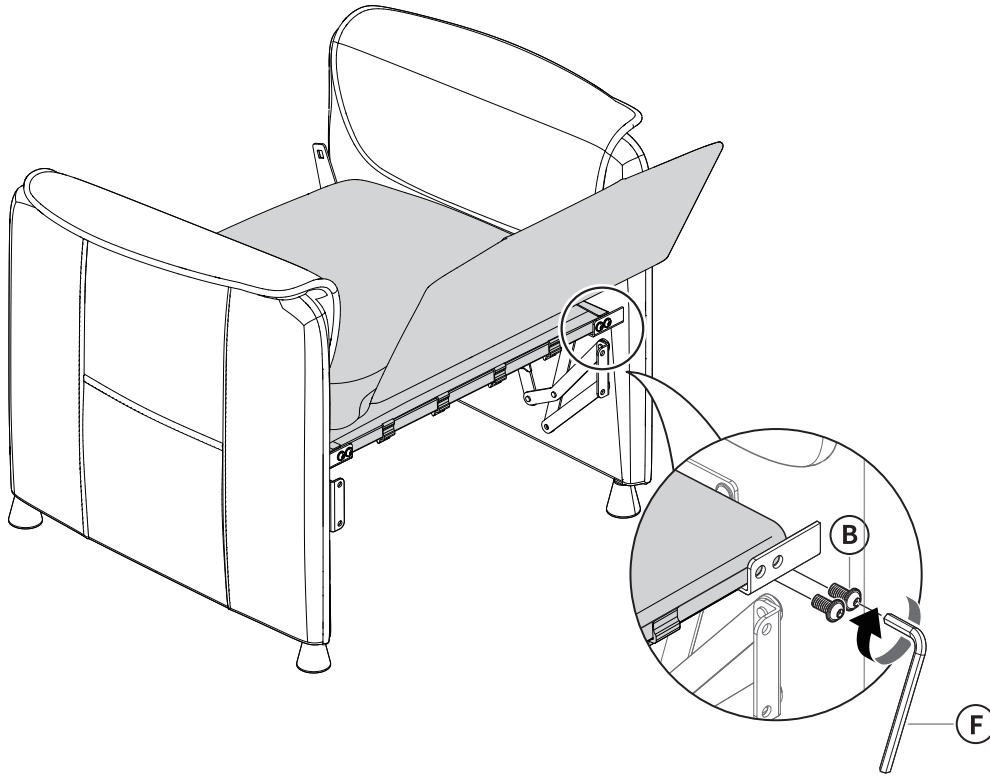

M8 x 20mm

(B) x 2

3/16" (5mm)

(F) x 1

Note: Do not tighten bolts fully until step 6 is completed!

Remarque : Ne vissez pas complètement les boulons avant que l'étape 5 ne soit terminée !

Hinweis: Ziehen Sie die Schrauben nicht vollständig fest, bevor Schritt 5 abgeschlossen ist!

Nota: ¡No apriete completamente los pernos hasta que el paso 5 esté completado!

Nota: Não aperte completamente os parafusos até que a etapa 5 esteja concluída!

Nota: Non stringere completamente i bulloni finché il passaggio 5 non è completato!

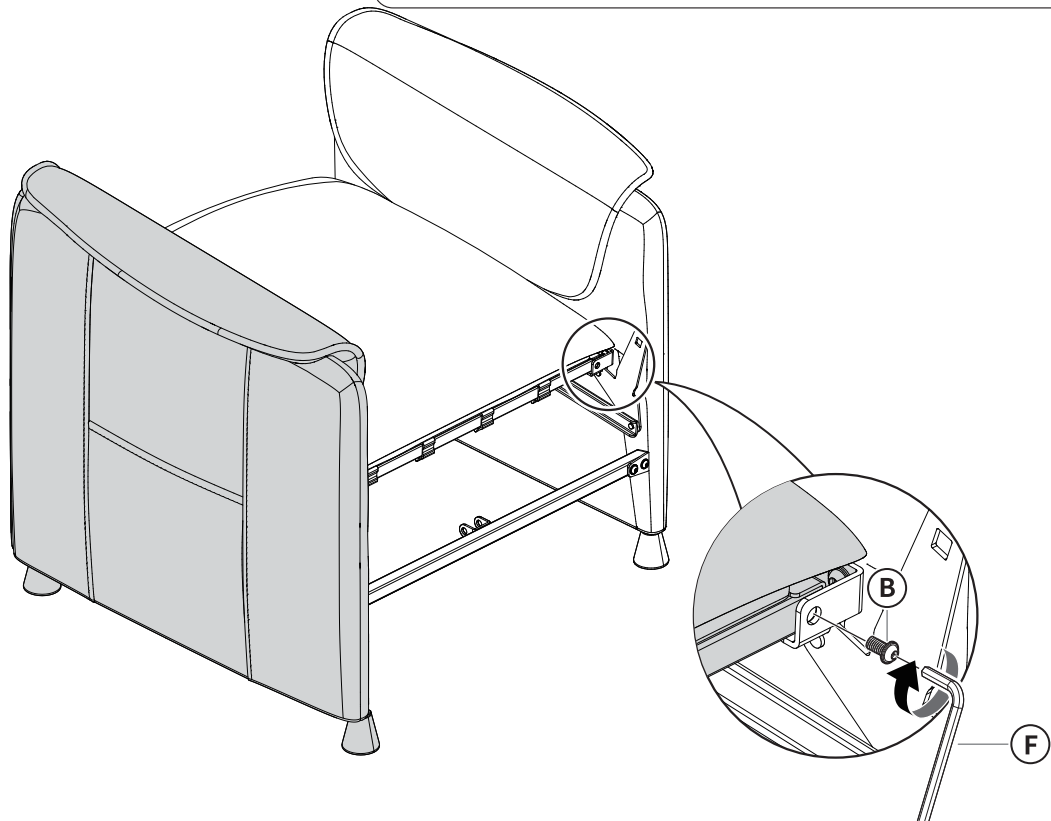

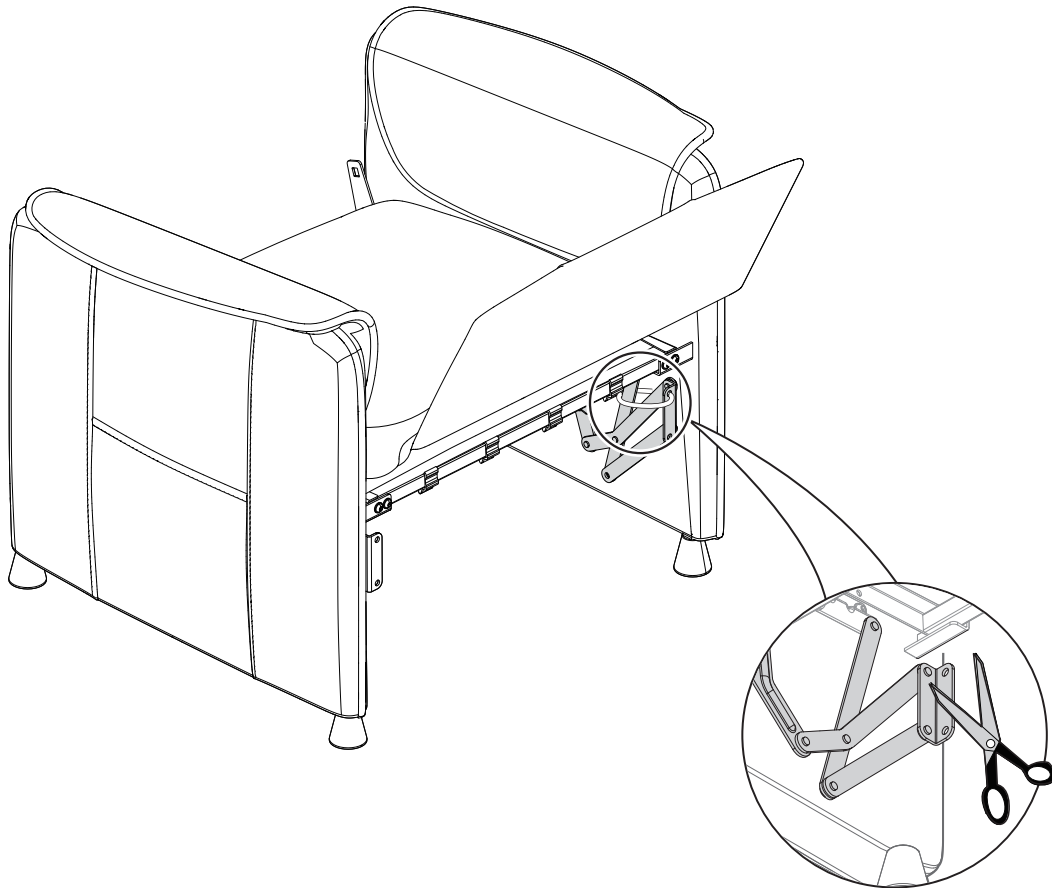

CUT THE TIES



M6 x 15mm





3/16" (5mm)

C x 4

F x 1

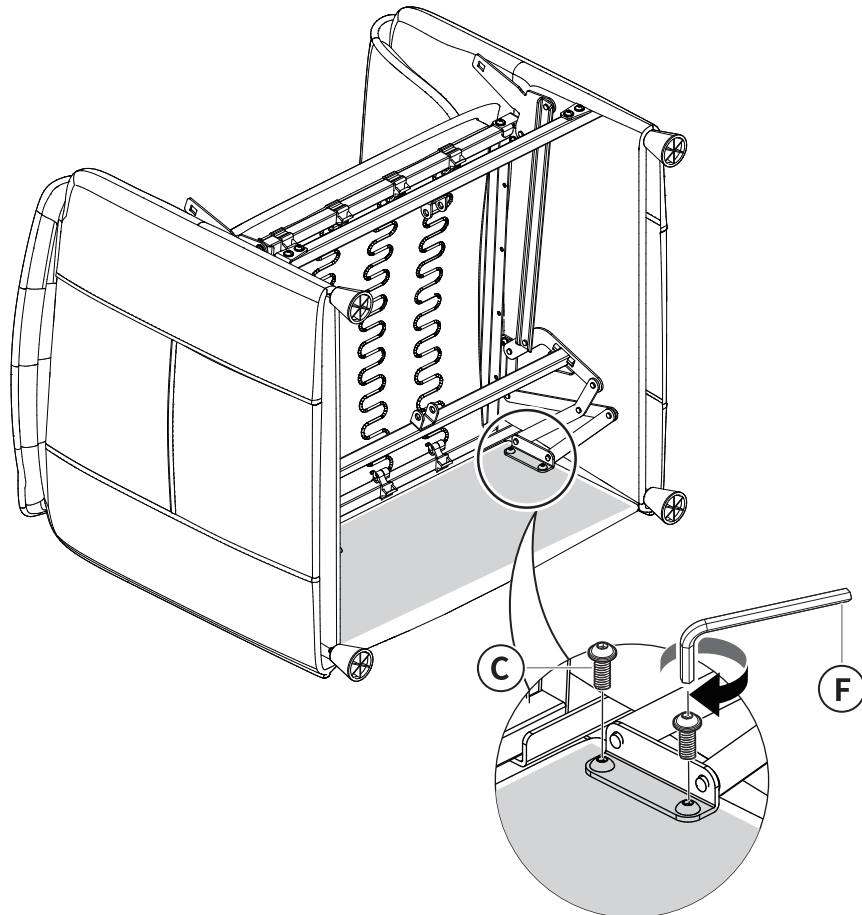
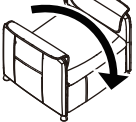
90



-  Ø10 x 40mm
- 
- D** x 2
- E** x 2

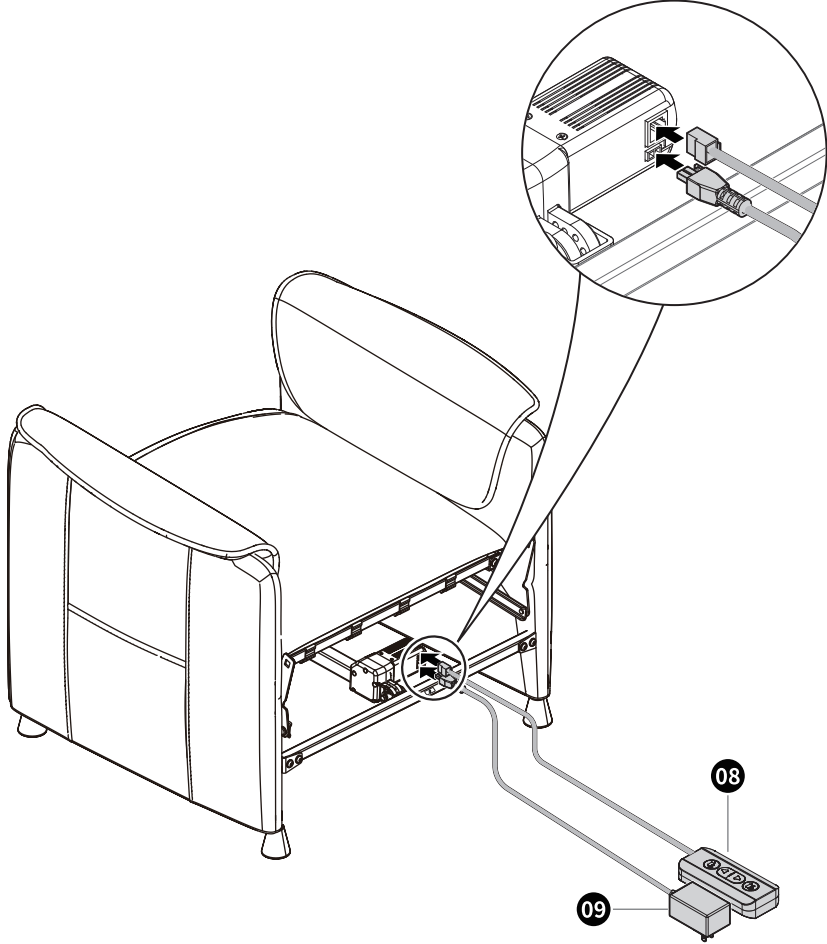
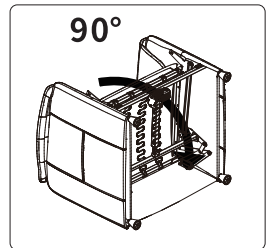
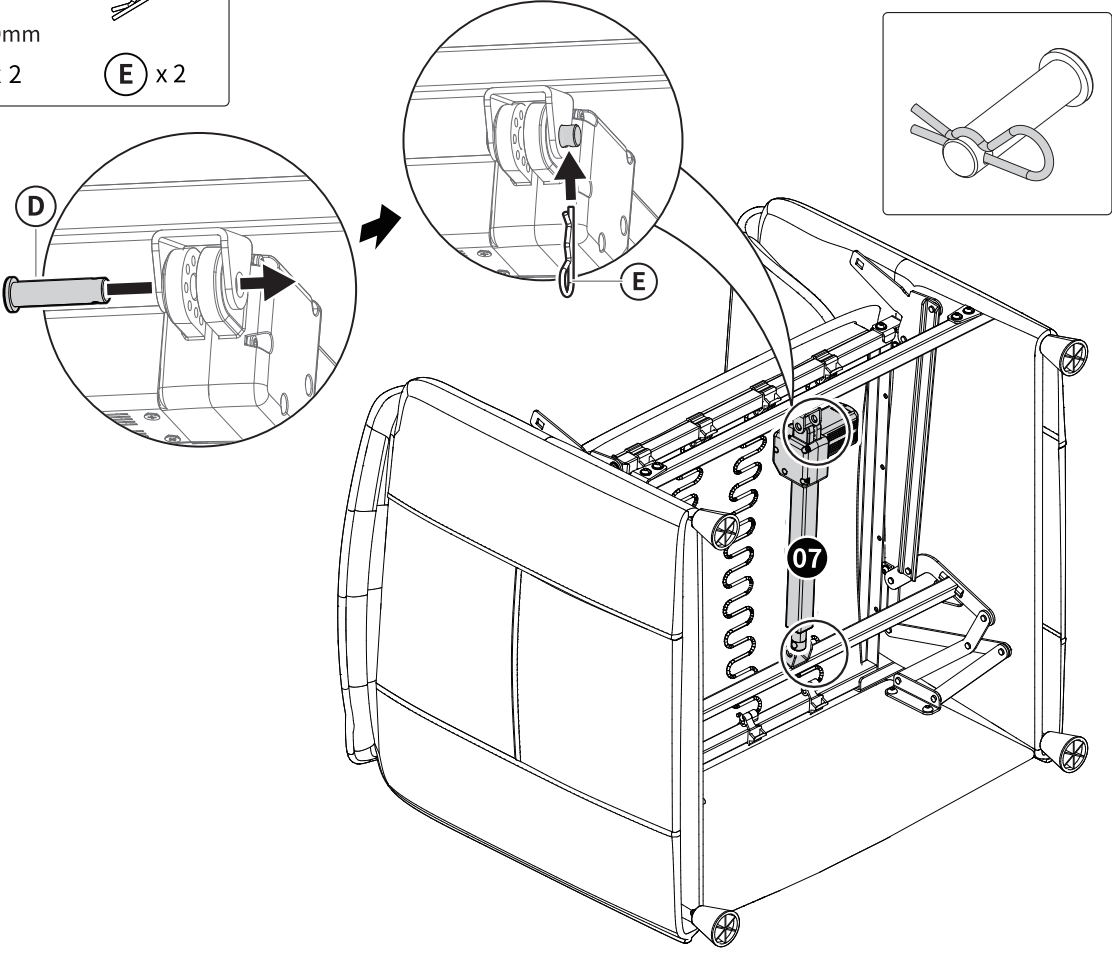



TIP: Zip up to connect the two parts.

Astuce : Fermez la fermeture éclair pour connecter les deux parties.

Tipp: Ziehen Sie den Reißverschluss zu, um die beiden Teile zu verbinden.

Consejo: Sube la cremallera para conectar las dos partes.

Dica: Feche o zíper para conectar as duas partes.

Suggerimento: Chiudi la cerniera per collegare le due parti.

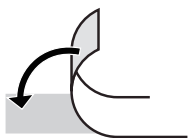
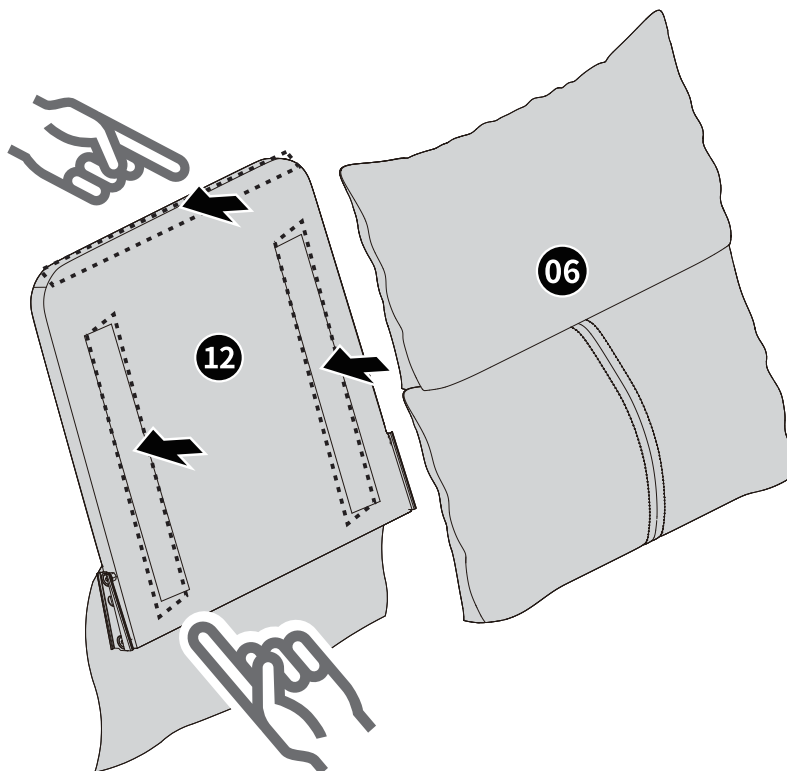

TIP: TIP: Align and attach the hook and loop fasteners for a secure connection.

CONSEIL : Alignez et fixez les attaches auto-agrippantes pour une connexion sécurisée.

TIPP: Richten Sie die Klettverschlüsse aus und befestigen Sie sie für eine sichere Verbindung.

CONSEJO: Alinee y fije los cierres de gancho y bucle para una conexión segura.

DICA: Alinhe e fixe os fechos de gancho e laço para uma conexão segura.

CONSIGLIO: Allinea e fissa i nastri a strappo per una connessione sicura.

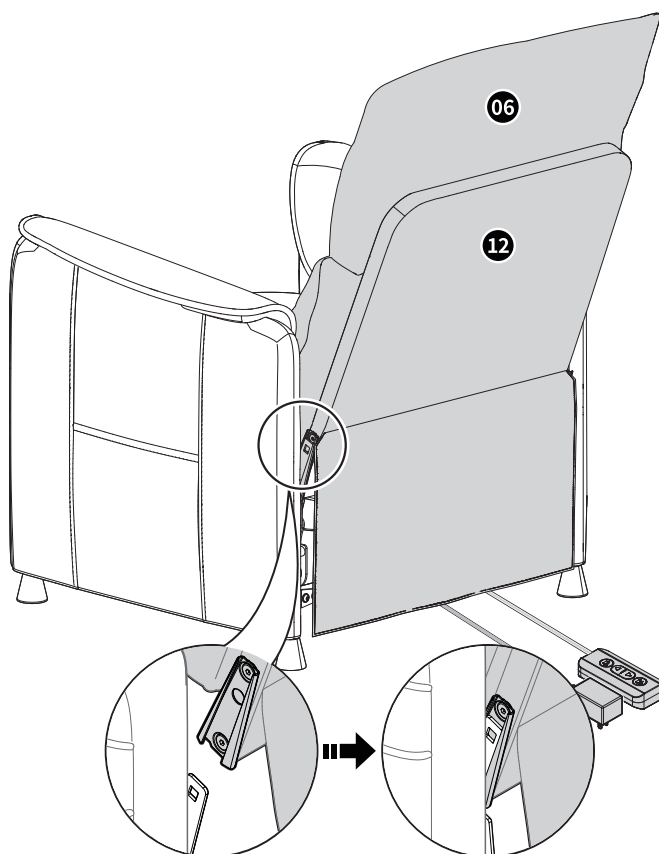

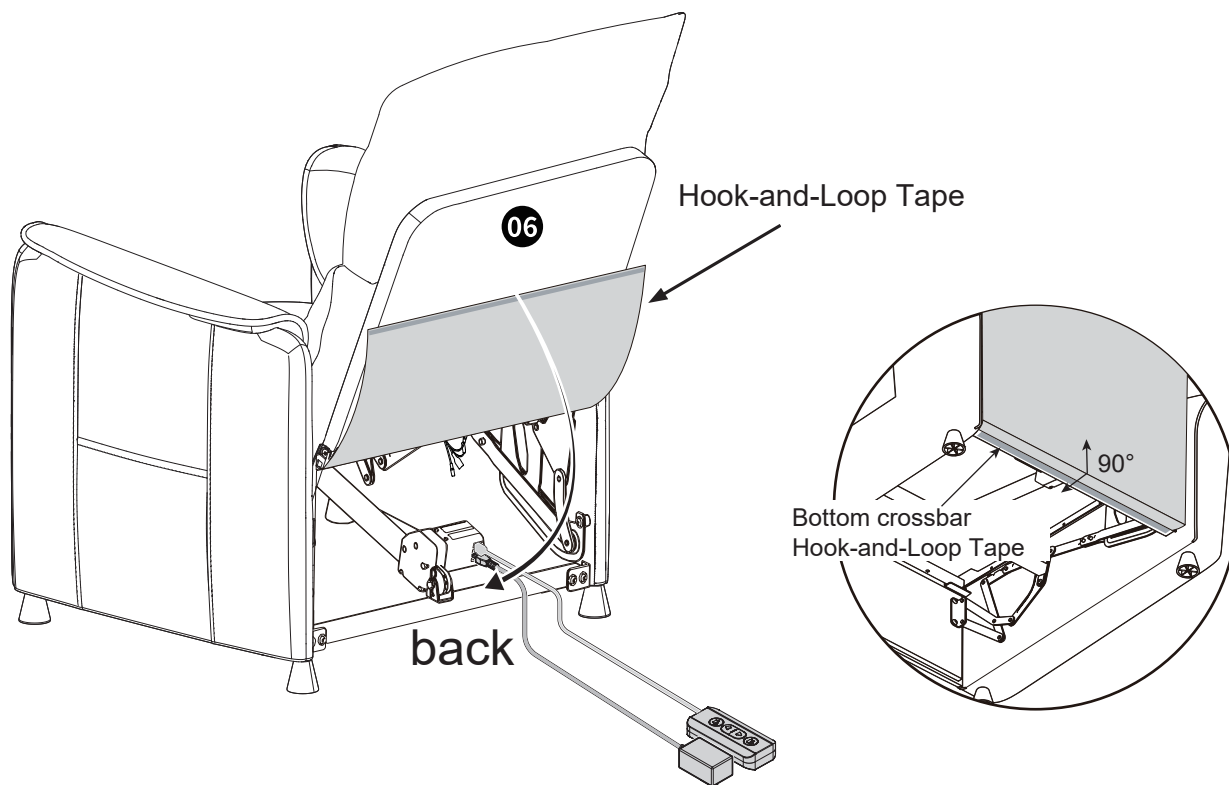

- EN** Attach the cloth to the Hook-and-Loop Tape on the lower crossbar at the couch base.
FR Fixez le tissu à la fermeture à crochets et boucles sur la traverse inférieure à la base du canapé.
ES Fija la tela al cierre de gancho y bucle en la barra transversal inferior en la base del sofá.
PT Prenda o pano ao fecho de gancho e laço na barra transversal inferior na base do sofá.
DE Befestigen Sie das Tuch am Haken- und Schlaufenverschluss der unteren Querstange an der Sofabasis.
IT Fissa il tessuto alla chiusura a strappo sulla barra trasversale inferiore alla base del divano.

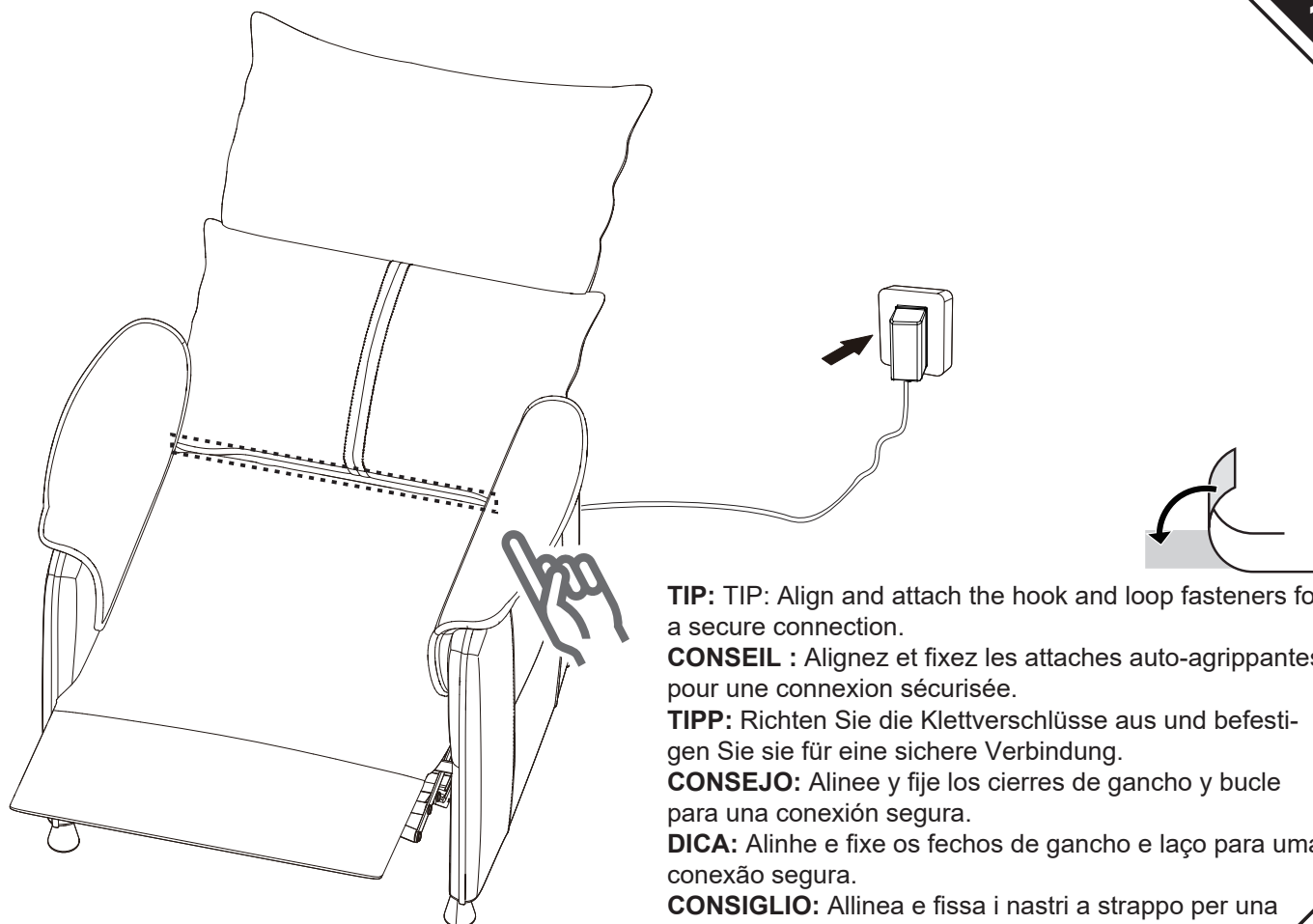

TIP: TIP: Align and attach the hook and loop fasteners for a secure connection.

CONSEIL : Aligned et fixez les attaches auto-agrippantes pour une connexion sécurisée.

TIPP: Richten Sie die Klettverschlüsse aus und befestigen Sie sie für eine sichere Verbindung.

CONSEJO: Alinee y fije los cierres de gancho y bucle para una conexión segura.

DICA: Alinhe e fixe os fechos de gancho e laço para uma conexão segura.

CONSIGLIO: Allinea e fissa i nastri a strappo per una connessione sicura.

Manual controller instructions

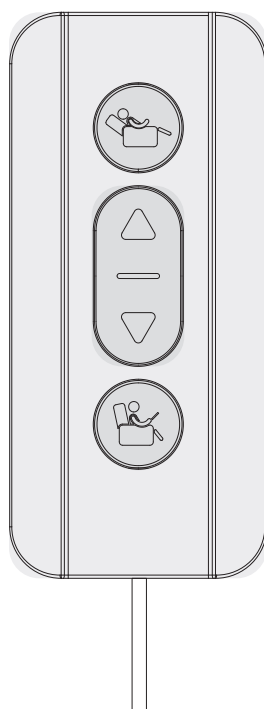





1. Regular Setup Guide

“” Long press and hold this button to make the couch recline. Release whenever you reach your favorite reclining angle.



“” Long press this button to raise the couch. Let go when you’ve found the perfect sitting position.

2. Memory Function

Save Your Favorite Position: Hold down the button “” or “” for 3 seconds. Your current couch position will be saved as a memory.

Recall Your Saved Position: Simply tap the button “” or “”, the couch will adjust to your saved memory position.

3. Resetting

If the couch does not work suddenly, press and hold both the buttons “” and “” for 5 seconds, you can force it return to the upright position, then can use again.

Input voltage	100-240	V
Input AC frequency	50/60	Hz
Output voltage	29	V
Output current	1.0	A
Output power	29	W
Average active efficiency	88.2	%
Efficiency at low load (10 %)	88	%
No-load power consumption	0.1	W

Instructions du contrôleur manuel

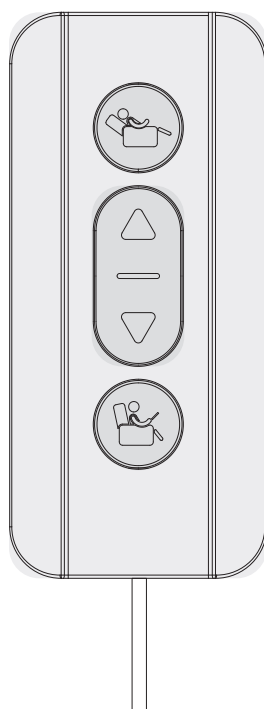





1. Guide de configuration standard

"  " : Appuyez longuement sur ce bouton pour incliner le canapé. Relâchez lorsque vous atteignez l'angle d'inclinaison souhaité.



"  " : Appuyez longuement sur ce bouton pour relever le canapé. Relâchez lorsque vous avez trouvé la position assise idéale.

2. Fonction de mémoire

Enregistrer votre position préférée : Maintenez enfoncé le bouton "  " ou "  " pendant 3 secondes. La position actuelle du canapé sera enregistrée en mémoire.

Rappeler votre position enregistrée : Appuyez simplement sur le bouton "  " ou "  ", le canapé s'ajustera à la position mémorisée.

3. Réinitialisation

Si le canapé cesse soudainement de fonctionner, maintenez enfoncés les boutons "  " et "  " pendant 5 secondes. Cela forcera le canapé à revenir en position verticale, et vous pourrez l'utiliser à nouveau.

Tension d'entrée	100-240	V
Fréquence AC d'entrée	50/60	Hz
Tension de sortie	29	V
Courant de sortie	1.0	A
Puissance de sortie	29	W
Efficacité active moyenne	88.2	%
Efficacité à faible charge (10 %)	88	%
Consommation d'énergie à vide	0.1	W

Anleitung für den manuellen Controller

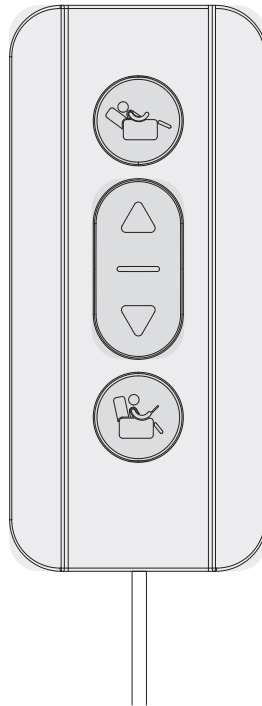

1. Standard-Einrichtungsanleitung

"△": Drücken und halten Sie diesen Knopf, um das Sofa zurückzulehnen. Lassen Sie los, sobald Sie den gewünschten Neigungswinkel erreicht haben.

"▽": Drücken und halten Sie diesen Knopf, um das Sofa anzuheben. Lassen Sie los, wenn Sie die perfekte Sitzposition gefunden haben.

2. Speicherfunktion

Ihre Lieblingsposition speichern: Halten Sie den Knopf "⊞" oder "⊞" für 3 Sekunden gedrückt. Die aktuelle Position des Sofas wird als Speicher gespeichert.

Gespeicherte Position abrufen: Tippen Sie einfach auf den Knopf "⊞" oder "⊞", das Sofa stellt sich automatisch auf die gespeicherte Position ein.

3. Zurücksetzen

Falls das Sofa plötzlich nicht mehr funktioniert, drücken und halten Sie die Knöpfe "⊞" und "⊞" gleichzeitig für 5 Sekunden. Das Sofa wird zwangsweise in die aufrechte Position zurückgebracht und kann danach wieder verwendet werden.

Eingangsspannung	100-240	V
Eingangswechselstromfrequenz	50/60	Hz
Ausgangsspannung	29	V
Ausgangsstrom	1.0	A
Ausgangsleistung	29	W
Durchschnittliche aktive Effizienz	88.2	%
Effizienz bei niedriger Last (10 %)	88	%
Leerlaufstromverbrauch	0.1	W

Instrucciones del controlador manual

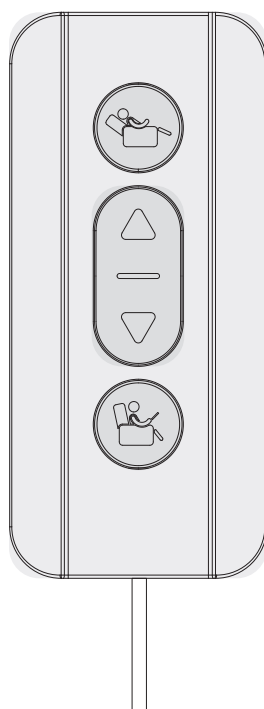

1. Guía de configuración estándar

"△": Mantén presionado este botón para reclinarse el sofá. Suelta cuando alcances el ángulo de inclinación que prefieras.

"▽": Mantén presionado este botón para levantar el sofá. Suelta cuando encuentres la posición sentada perfecta.

2. Función de memoria

Guardar tu posición favorita: Mantén presionado el botón "👤" o "👤" durante 3 segundos. La posición actual del sofá se guardará en la memoria.

Recuperar tu posición guardada: Simplemente presiona el botón "👤" o "👤", y el sofá se ajustará a la posición memorizada.

3. Restablecimiento

Si el sofá deja de funcionar repentinamente, mantén presionados los botones "👤" y "👤" durante 5 segundos. Esto forzará al sofá a volver a la posición vertical, y podrás usarlo de nuevo.

Voltaje de entrada	100-240	V
Frecuencia de entrada AC	50/60	Hz
Voltaje de salida	29	V
Corriente de salida	1.0	A
Potencia de salida	29	W
Eficiencia activa promedio	88.2	%
Eficiencia a baja carga (10 %)	88	%
Consumo de energía en vacío	0.1	W

Instruções do controlador manual

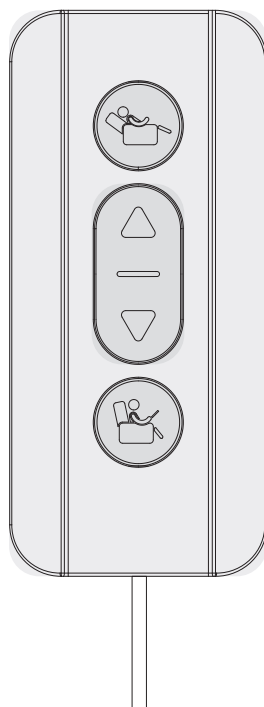





1. Guia de configuração padrão

"  ": Pressione e segure este botão para reclinar o sofá. Solte quando atingir o ângulo de reclinção desejado.



"  ": Pressione e segure este botão para levantar o sofá. Solte quando encontrar a posição sentada perfeita.

2. Função de memória

Salvar sua posição favorita: Mantenha pressionado o botão "  " ou "  " por 3 segundos. A posição atual do sofá será salva na memória.

Recuperar a posição salva: Basta tocar no botão "  " ou "  ", e o sofá ajustará automaticamente para a posição memorizada.

3. Redefinição

Se o sofá parar de funcionar repentinamente, pressione e segure os botões "  " e "  " por 5 segundos. Isso forçará o sofá a retornar à posição vertical, e você poderá usá-lo novamente.

Voltagem de entrada	100-240	V
Frequência de entrada AC	50/60	Hz
Voltagem de saída	29	V
Corrente de saída	1.0	A
Potência de saída	29	W
Eficiência ativa média	88.2	%
Eficiência em baixa carga (10 %)	88	%
Consumo de energia em vazio	0.1	W

Istruzioni del controller manuale

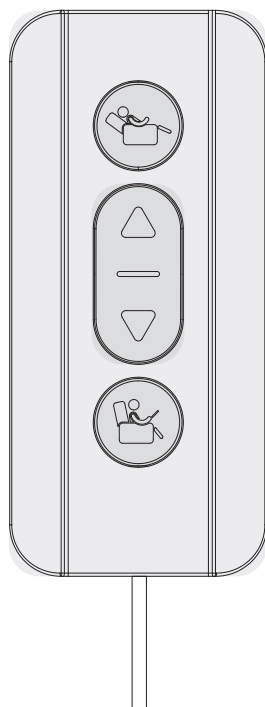





1. Guida alla configurazione standard

"  ": Premi a lungo questo pulsante per reclinare il divano. Rilascia quando raggiungi l'angolo di reclinazione desiderato.



"  ": Premi a lungo questo pulsante per sollevare il divano. Rilascia quando trovi la posizione seduta perfetta.

2. Funzione di memoria

Salva la tua posizione preferita: Tieni premuto il pulsante "  " o "  " per 3 secondi. La posizione attuale del divano verrà salvata in memoria.

Richiama la posizione salvata: Basta toccare il pulsante "  " o "  ", e il divano si regolerà automaticamente sulla posizione memorizzata.

3. Ripristino

Se il divano smette improvvisamente di funzionare, premi e tieni premuti i pulsanti "  " e "  " per 5 secondi. Questo forzerà il divano a tornare in posizione verticale, dopodiché potrà essere utilizzato nuovamente.

Tensione di ingresso	100-240	V
Frequenza AC di ingresso	50/60	Hz
Tensione di uscita	29	V
Corrente di uscita	1.0	A
Potenza di uscita	29	W
Efficienza media attiva	88.2	%
Efficienza a basso carico (10 %)	88	%
Consumo di energia a vuoto	0.1	W

If you have any questions, please contact our customer care center, Our contact details are below:

US

 001-877-644-9366

 customerservice@aosom.com

Imported by Aosom LLC
27150 SW Kinsman Rd Wilsonville, OR 97070 USA
MADE IN CHINA

If you have any questions, please contact our customer care center, Our contact details are below:

CA

 416-792-6088

 customerservice@aosom.ca

Imported by Aosom Canada Inc.
7270 Woodbine Avenue, Unit 307, Markham,
Ontario Canada L3R 4B9
MADE IN CHINA

Si vous avez la moindre question, veuillez contacter notre centre d'assistance à la clientèle, Nos coordonnées sont les suivantes:

 416-792-6088

 customerservice@aosom.ca

Importé par Aosom Canada Inc.
7270 Woodbine Avenue, unité 307,
Markham, Ontario Canada L3R 4B9
FABRIQUÉ EN CHINE

If you have any questions, please contact our customer care center, Our contact details are below:

UK

 0044-800-240-4004

 enquiries@mhstar.co.uk

IMPORTER ADDRESS:
MH STAR UK LTD
Unit 27, Perivale Park,
Horsenden lane South
Perivale, UB6 7RH
MADE IN CHINA

Si vous avez la moindre question, veuillez contacter notre centre d'assistance à la clientèle, Nos coordonnées sont les suivantes:

 0033-1-84166106

 aosom@mhfrance.fr

Importé par/Fabricant/REP:
MH FRANCE
2 Rue Maurice Hartmann
92130 Issy Les Moulineaux
France
FABRIQUÉ EN CHINE



FR

Cet appareil, ses accessoires, cordons et batteries se recyclent

REPRISE
À LA LIVRAISON



À DÉPOSER
EN MAGASIN



À DÉPOSER
EN DÉCHÈTERIE



Points de collecte sur www.quefairedemesdechets.fr
Privilégiez la réparation ou le don de votre appareil !

Wenn Sie Fragen haben, wenden Sie sich bitte an unser Kundendienstzentrum, Unsere Kontaktdaten stehen unten:

DE

 +49 40 87408465

 service@aosom.de

ADRESSE DES IMPORTEURE/Hersteller/REP:
MH Handel GmbH
Wendenstraße 309
D-20537 Hamburg
Germany
IN CHINA HERGESTELLT

In caso di dubbio, si prega di contattare il nostro centro assistenza clienti, I nostri dettagli di contatto sono di seguito:

IT

 0039-0249471447

 clienti@aosom.it

IMPORTATO DA/Produttore/REP:
AOSOM Italy srl
Centro Direzionale Milanofiori
Strada 1 Palazzo F1
20057 Assago (MI)
P.I.: 08567220960
FATTO IN CINA

Si tiene alguna pregunta, comuníquese con nuestro Centro de Atención al Cliente, Nuestros datos de contacto son los siguientes:

ES

 0034-931294512

 atencioncliente@aosom.es

IMPORTADOR/Fabricante/REP:
SPANISH AOSOM, S.L.
C/ROC GROS, N°15.08550, ELS HOSTALETES DE
BALENYÀ, SPAIN.
B66295775
HECHO EN CHINA

Se tiver alguma dúvida, por favor contacte o nosso Centro de Atendimento ao Cliente, Os nossos dados de contacto são os seguintes:

 0034-931294512

 info@aosom.pt.

IMPORTADOR/Fabricante/REP:
SPANISH AOSOM, S.L.
C.ROC GROS N.15, 08550. ELS HOSTALETES DE
BALENYÀ
FEITO NA CHINA

FR