

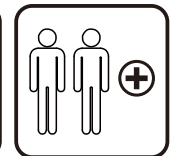

IN251100370V01\_GL

**84C-790V01**

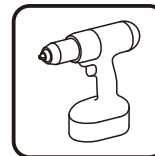
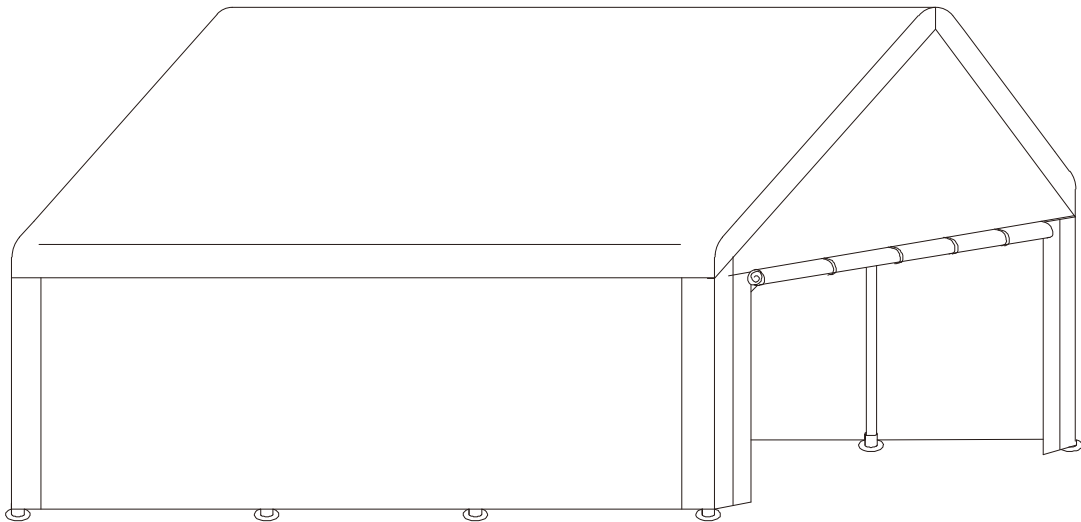

Tools Recommended

**EN\_IMPORTANT, RETAIN FOR FUTURE REFERENCE: READ CAREFULLY.**

**FR\_IMPORTANT: A LIRE ATTENTIVEMENT ET À CONSERVER POUR CONSULTATION ULTÉRIEURE.**

**ES\_IMPORTANTE, LEA Y GUARDE PARA FUTURAS REFERENCIAS.**

**PT\_IMPORTANTE, RETER PARA REFERÊNCIA FUTURA: LEIA ATENTAMENTE.**

**DE\_WICHTIG! SORFGFÄLTIG LESEN UND FÜR SPÄTERES NACHSCHLAGEN AUFBEWAHREN.**

**IT\_IMPORTANTE! CONSERVARE IL PRESENTE MANUALE PER FUTURO RIFERIMENTO E LEGGERLO ATTENTAMENTE.**

## BOX1

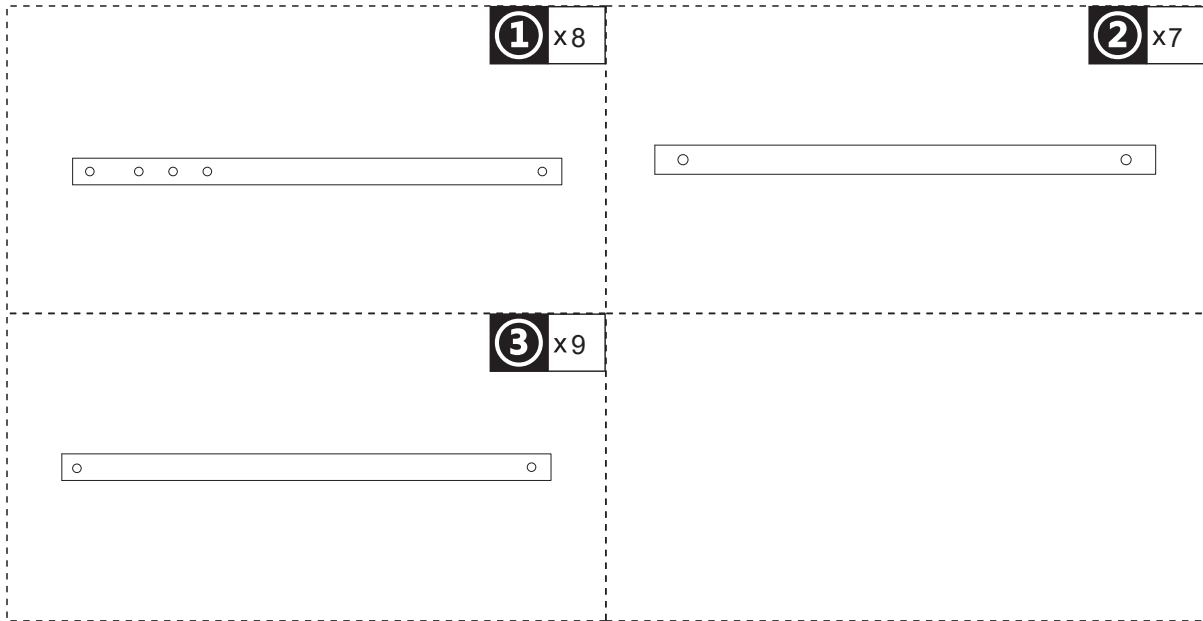

## BOX2

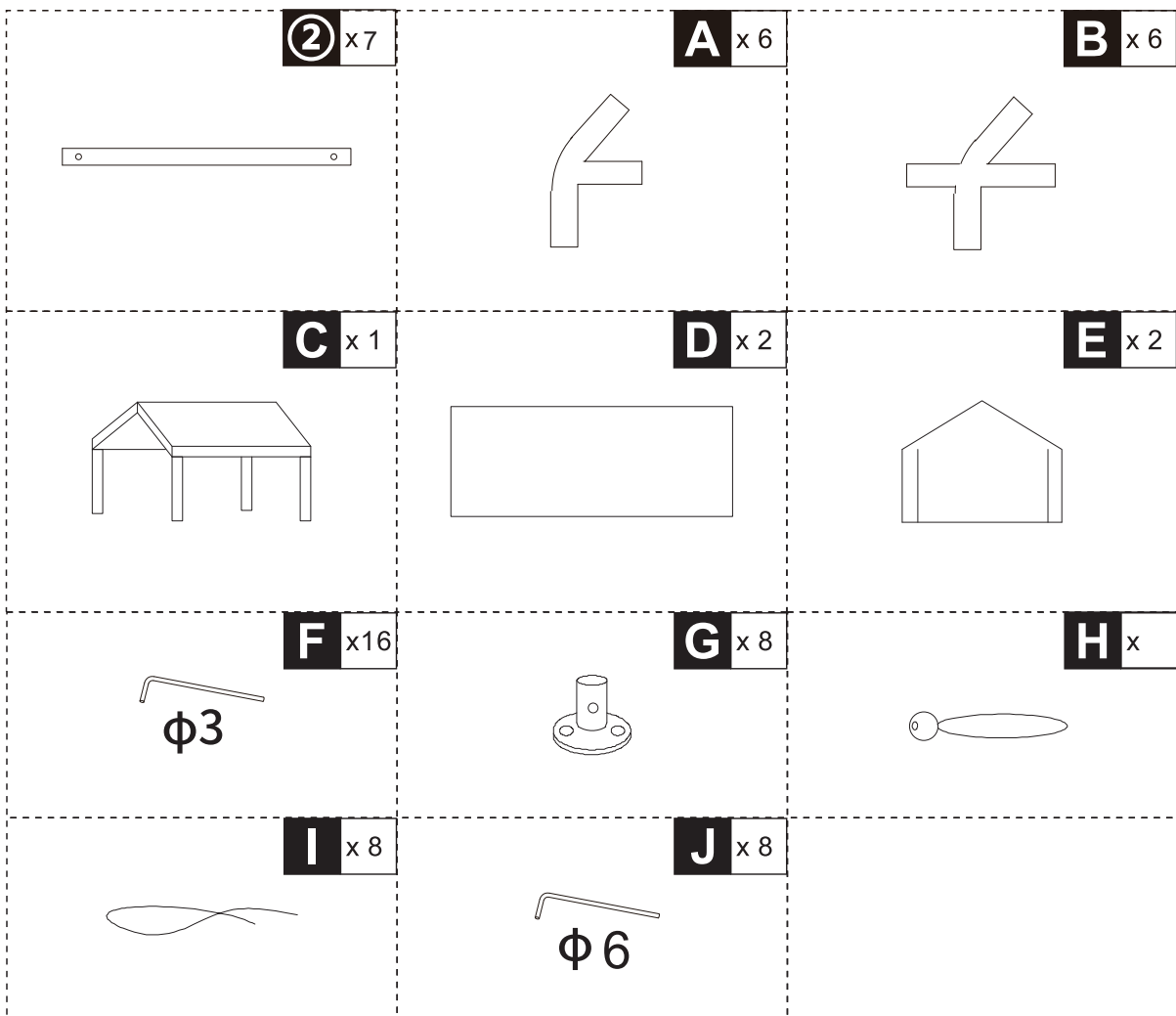



③3pcs



Ⓐ2pcs



Ⓑ2pcs

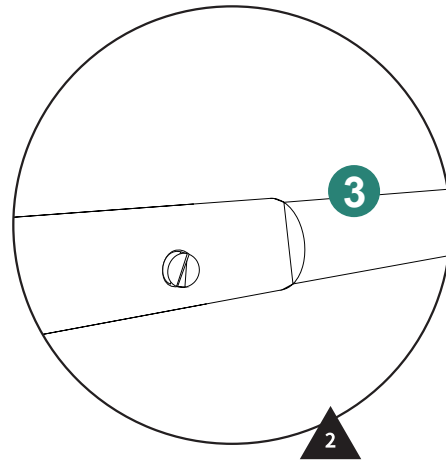
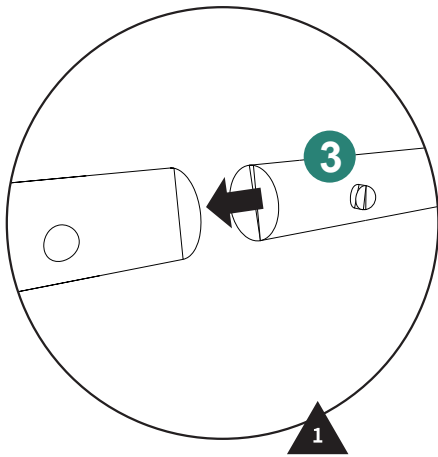
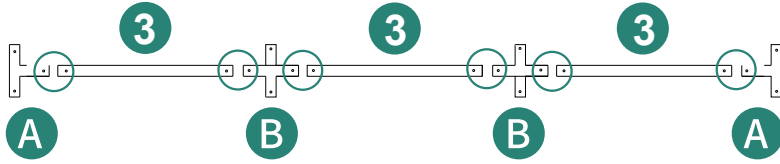

③6pcs



Ⓐ4pcs



Ⓑ4pcs

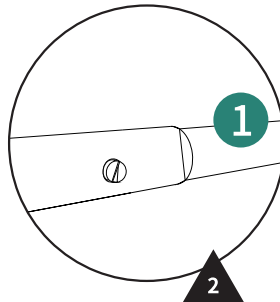
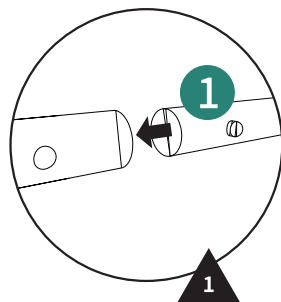
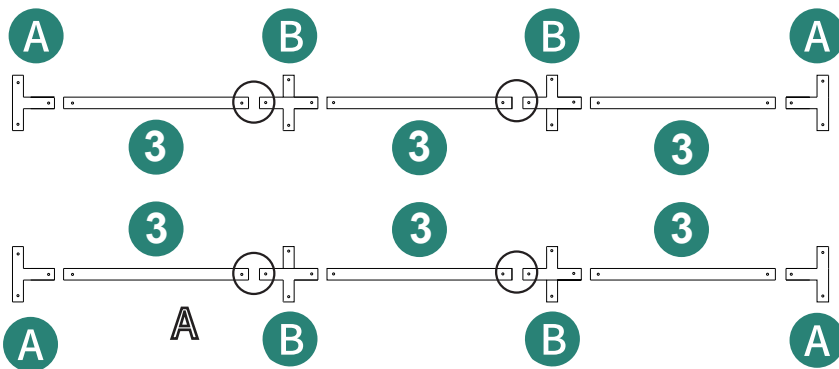



② 8pcs

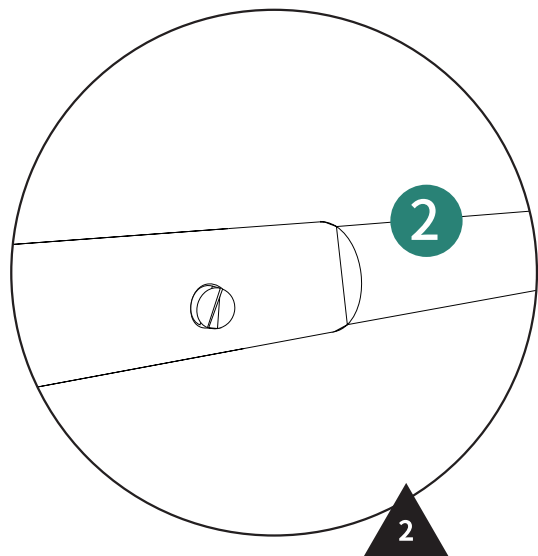
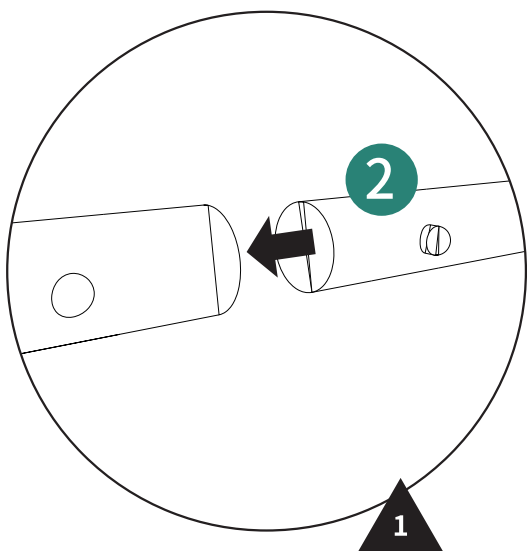
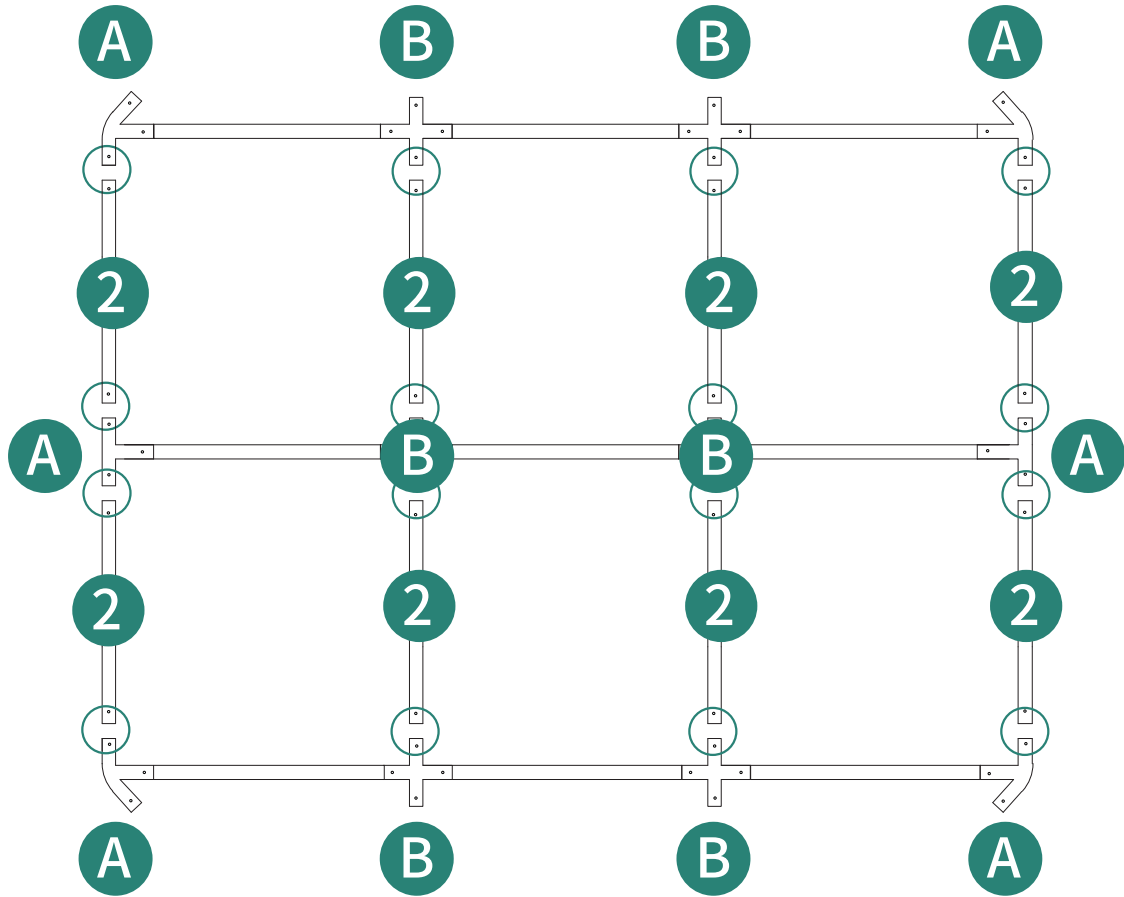

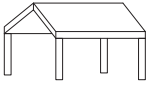

1pc



48pcs

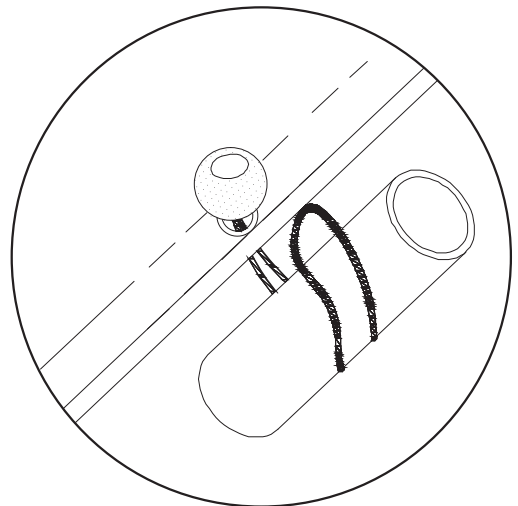
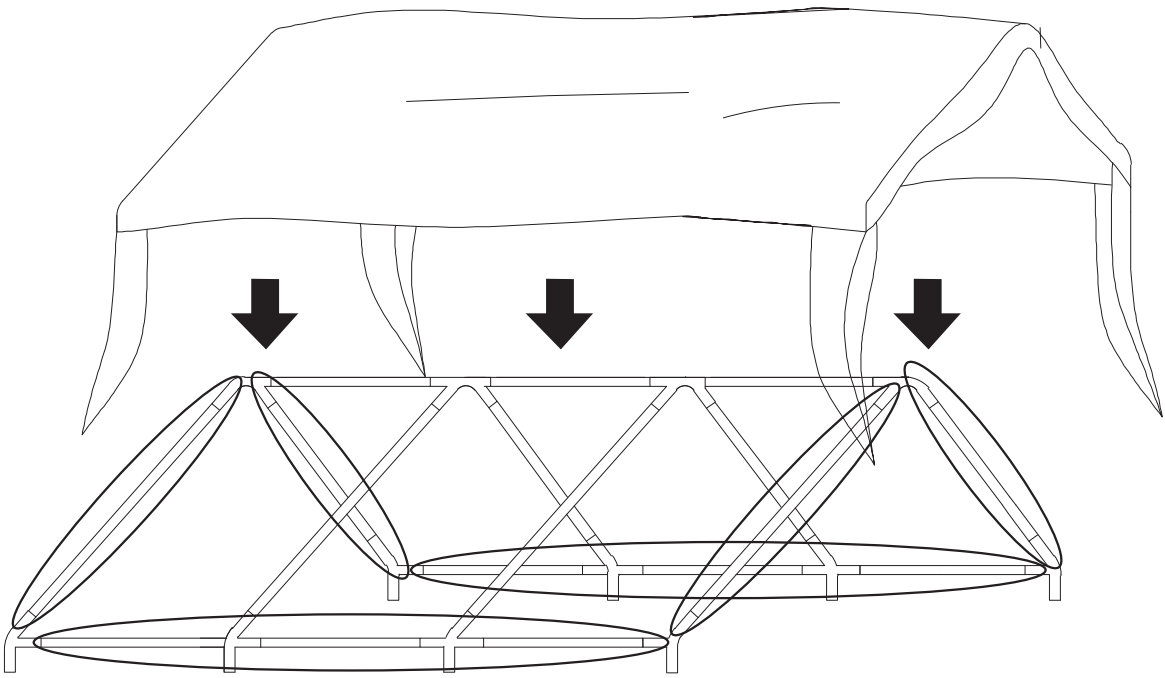



① 4pcs

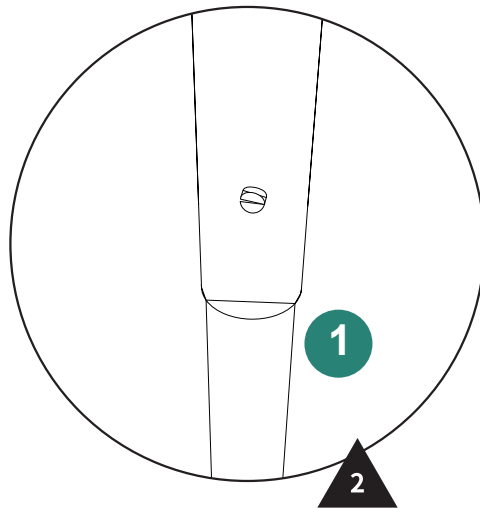
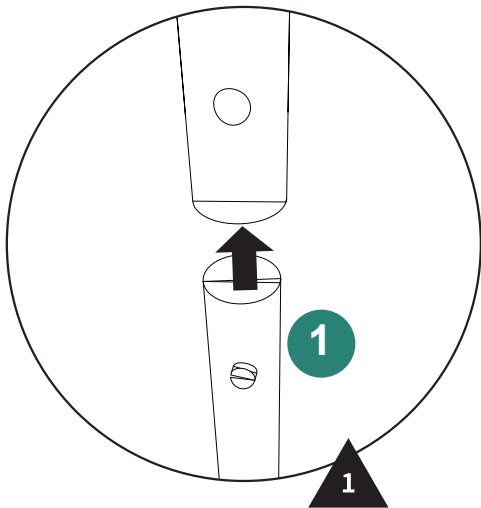
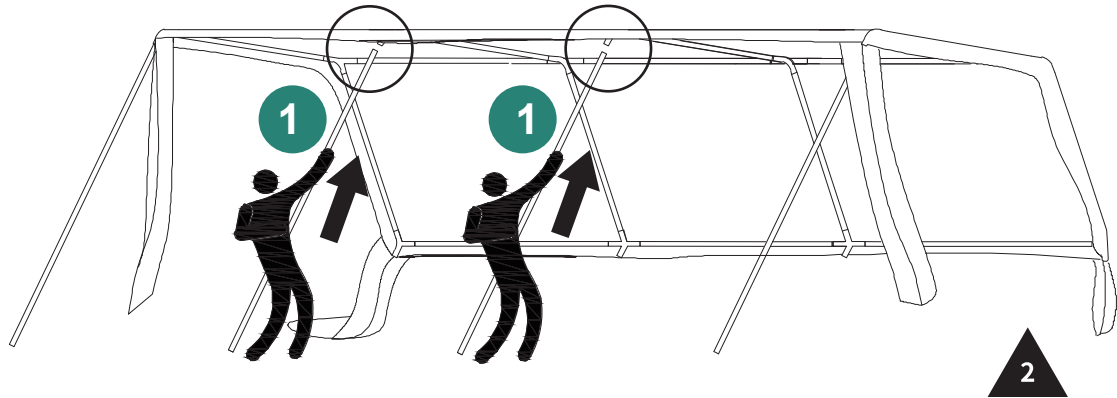
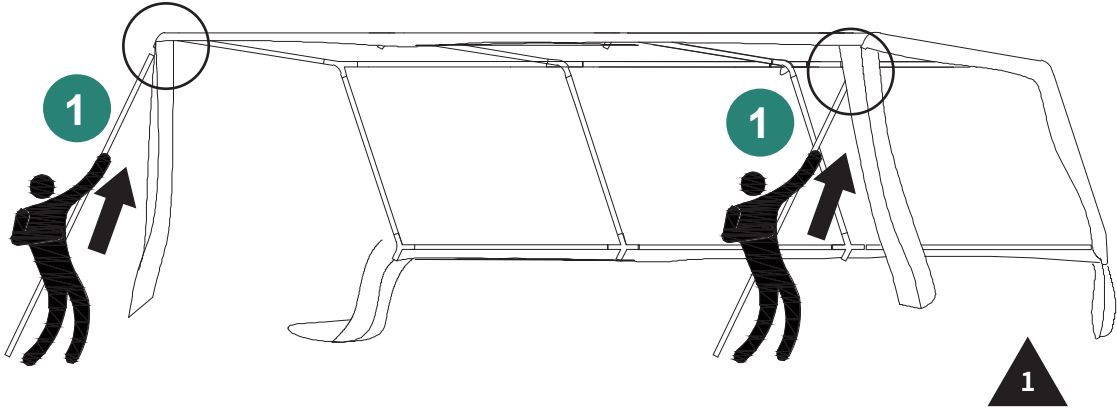

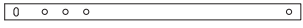

① 4pcs

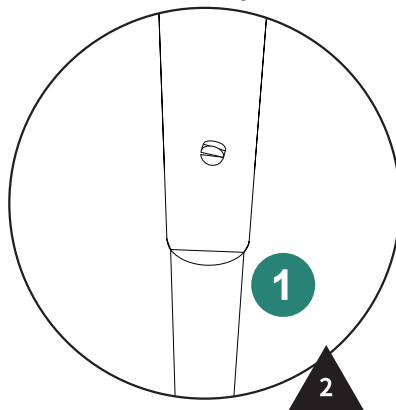
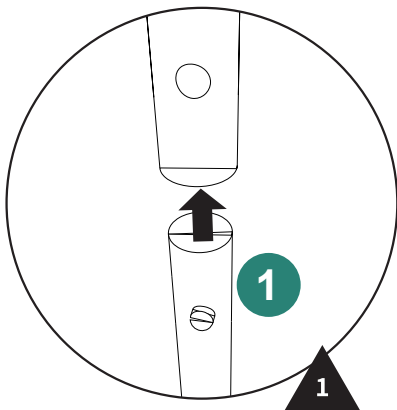
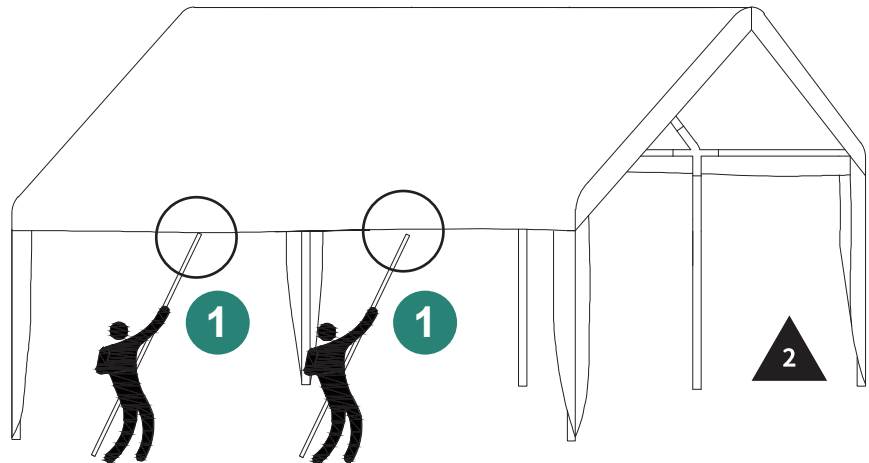
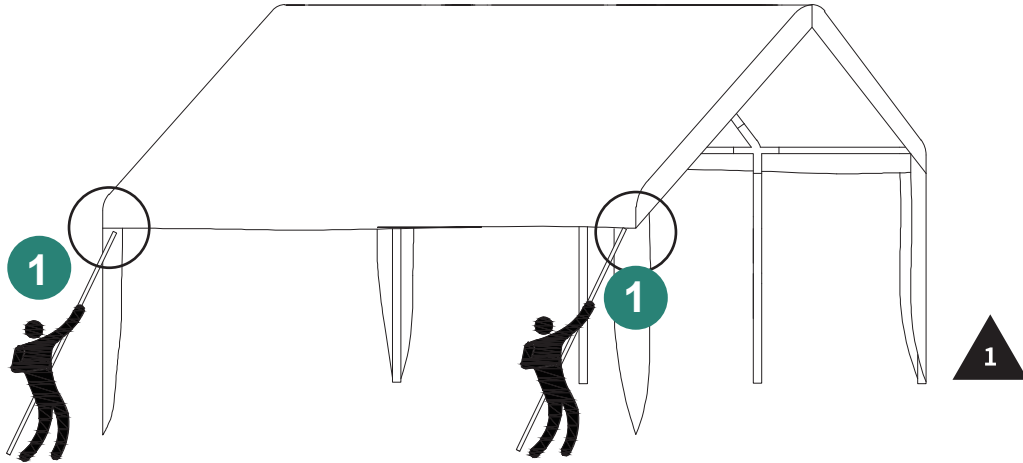



8pcs

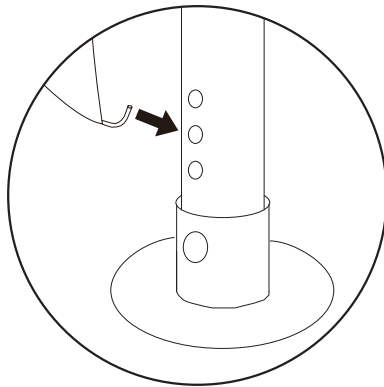
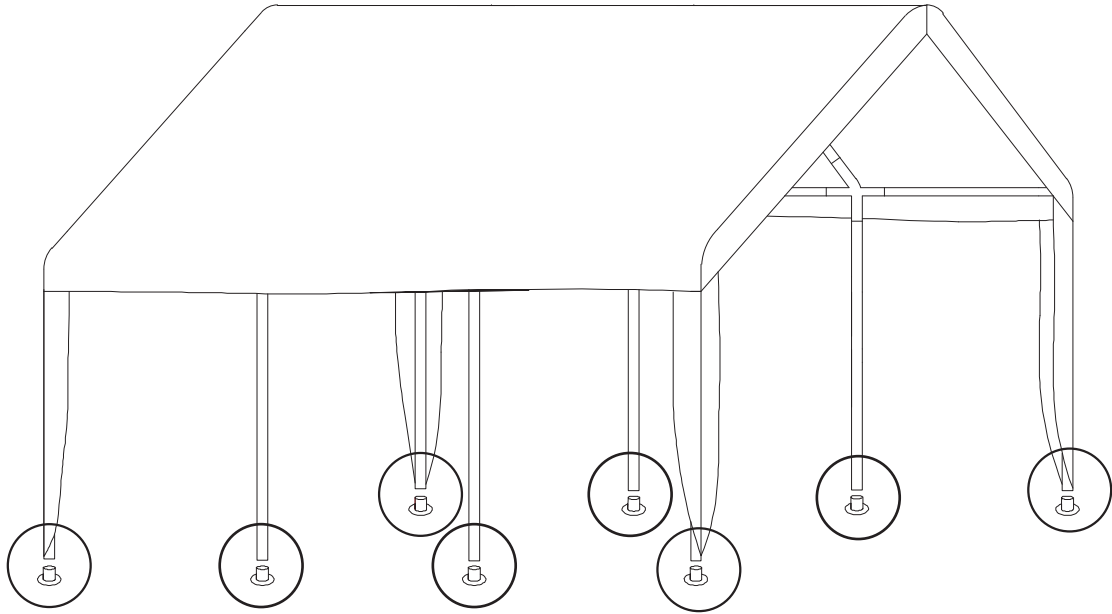



16pcs



2pcs

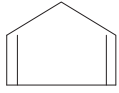

2pcs

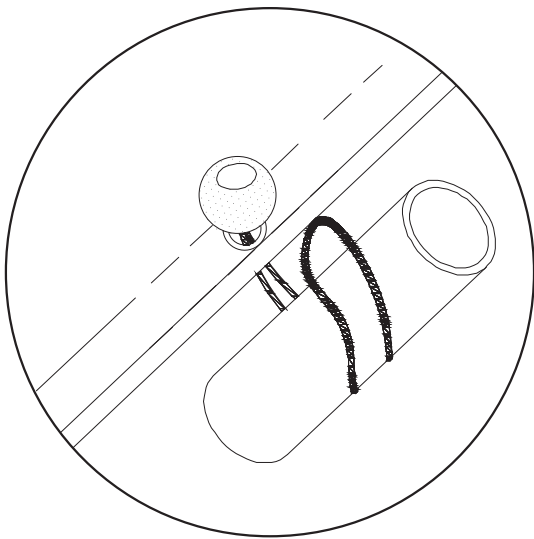
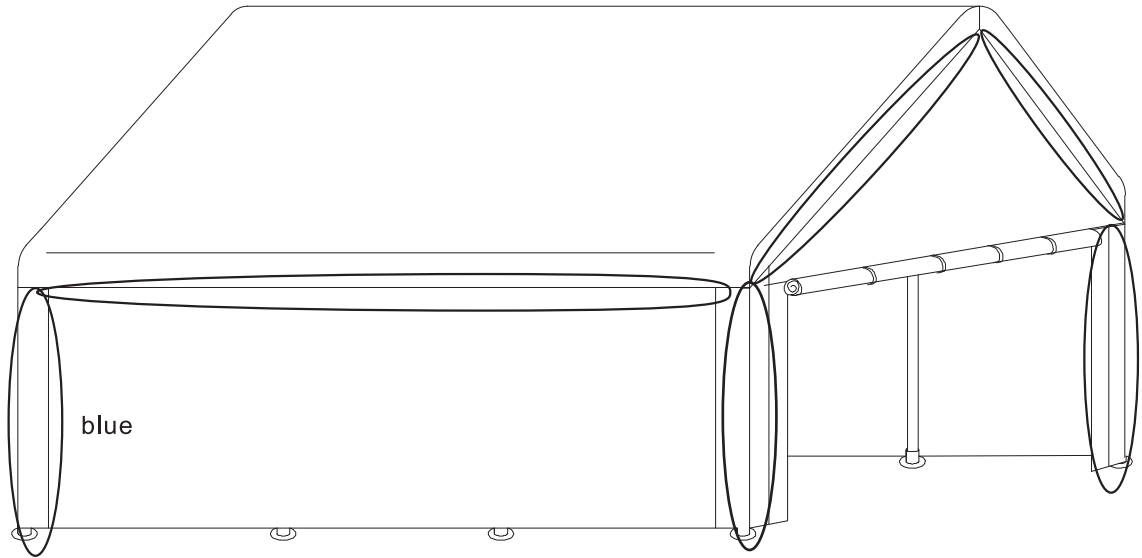

$\phi 3$   
16pcs

$\phi 6$   
8pcs

8pcs

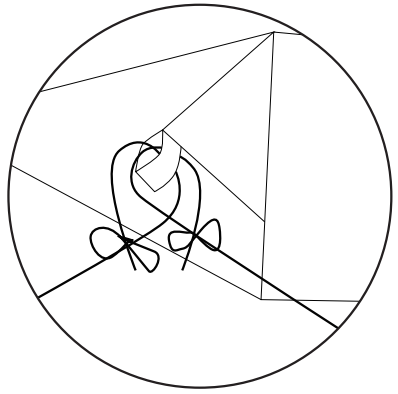
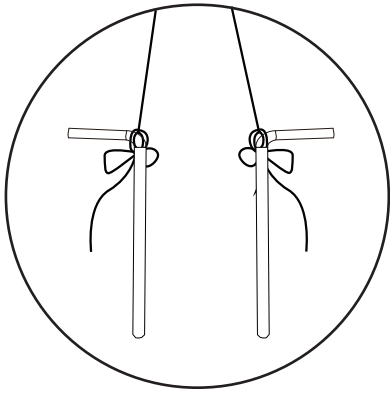
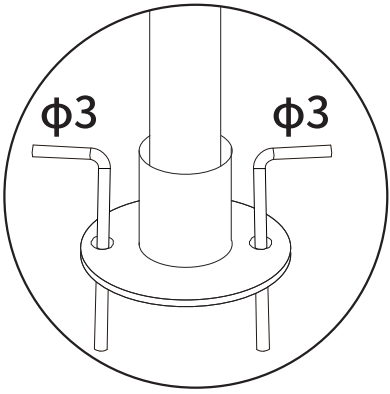
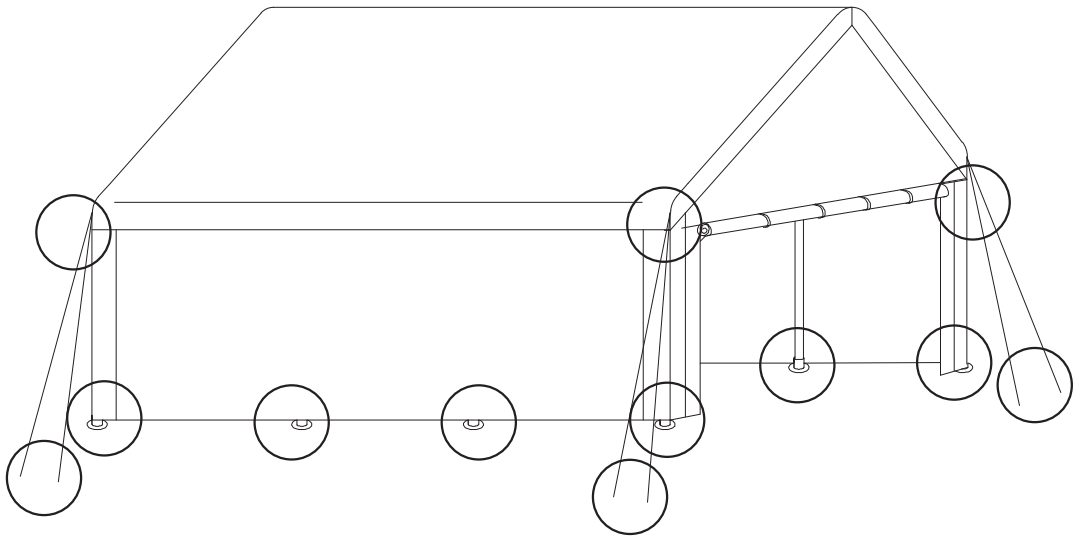

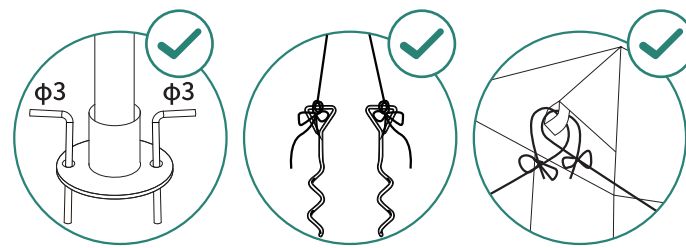

Grassy surfaces

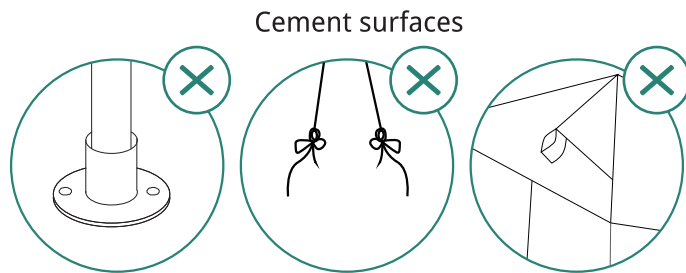

Cement surfaces

**EN**\_To improve wind resistance, be sure to complete this installation step. If expansion screws or ground nails are not installed, strong winds may topple the gazebo. Expansion screws are essential for stability on cement surfaces, and ground nails are for grassy surfaces.

Ground nails are included in the package while expansion screws are not provided.

**FR**\_Pour améliorer la résistance au vent, assurez-vous de compléter cette étape de l'installation. Si les vis d'expansion ou les clous de sol ne sont pas installés, les vents forts peuvent faire basculer le gazebo.

Les vis d'expansion sont essentielles pour assurer la stabilité sur les surfaces en ciment, et les clous de sol le sont pour les surfaces herbeuses.

Les clous de sol sont inclus dans l'emballage, tandis que les vis d'expansion ne sont pas fournies.

**ES**\_Para mejorar la resistencia al viento, asegúrese de completar este paso de la instalación. Si no se instalan tornillos de expansión o clavos de tierra, los vientos fuertes pueden derribar el cenador.

Los tornillos de expansión son esenciales para la estabilidad en superficies de cemento, y los clavos de tierra son para superficies cubiertas de hierba.

Los clavos de tierra se incluyen en el paquete, mientras que los tornillos de expansión no.

**PT**\_Para melhorar a resistência ao vento, não se esqueça de concluir esta etapa da instalação. Se os parafusos de expansão ou os pregos de solo não forem instalados, ventos fortes podem derrubar o gazebo.

Os parafusos de expansão são essenciais para a estabilidade em superfícies de cimento, e os pregos de solo são para superfícies relvadas.

Os pregos de solo estão incluídos na embalagem, enquanto os parafusos de expansão não são fornecidos.

**DE**\_Zur Verbesserung der Windbeständigkeit, stellen Sie sicher, dass dieser Montageschritt abgeschlossen ist. Wenn keine Dehnschrauben oder Erdnägel angebracht werden, kann der Pavillon bei starkem Wind umkippen.

Dehnungsschrauben sind für die Stabilität auf Zementoberflächen unerlässlich, während Erdnägel für grasbewachsene Oberflächen geeignet sind.

Erdnägel sind in der Verpackung enthalten, während Dehnungsschrauben nicht mitgeliefert werden.

**IT**\_Per migliorare la resistenza al vento, assicurarsi di completare questa fase di installazione. Se non si installano le viti a espansione o i chiodi a terra, il forte vento può far cadere il gazebo.

Le viti a espansione sono essenziali per la stabilità delle superfici in cemento, mentre i chiodi a terra sono indicati per le superfici erbose.

I chiodi a terra sono inclusi nella confezione, mentre le viti a espansione non sono fornite.

If you have any questions, please contact our customer care center, Our contact details are below:

**US**

 001-877-644-9366

 customerservice@aosom.com

Imported by Aosom LLC  
27150 SW Kinsman Rd Wilsonville, OR 97070 USA  
MADE IN CHINA

If you have any questions, please contact our customer care center, Our contact details are below:

**CA**

 416-792-6088

 customerservice@aosom.ca

Imported by Aosom Canada Inc.  
7270 Woodbine Avenue, Unit 307, Markham,  
Ontario Canada L3R 4B9  
MADE IN CHINA

Si vous avez la moindre question, veuillez contacter notre centre d'assistance à la clientèle, Nos coordonnées sont les suivantes:

 416-792-6088

 customerservice@aosom.ca

Importé par Aosom Canada Inc.  
7270 Woodbine Avenue, unité 307,  
Markham, Ontario Canada L3R 4B9  
FABRIQUÉ EN CHINE

If you have any questions, please contact our customer care center, Our contact details are below:

**UK**

 0044-800-240-4004

 enquiries@mhstar.co.uk

IMPORTER ADDRESS:  
MH STAR UK LTD  
Unit 27, Perivale Park,  
Horsenden lane South  
Perivale, UB6 7RH  
MADE IN CHINA

Si vous avez la moindre question, veuillez contacter notre centre d'assistance à la clientèle, Nos coordonnées sont les suivantes:

**FR**

 0033-1-84166106

 aosom@mhfrance.fr

Importé par/Fabricant/REP:  
MH FRANCE  
2 Rue Maurice Hartmann  
92130 Issy Les Moulineaux  
France  
FABRIQUÉ EN CHINE

Wenn Sie Fragen haben, wenden Sie sich bitte an unser Kundendienstzentrum, Unsere Kontaktdaten stehen unten:

**DE**

 0049-0(40)-87408465

 service@aosom.de

ADRESSE DES IMPORTEURE/Hersteller/REP:  
MH Handel GmbH  
Wendenstraße 309  
D-20537 Hamburg  
Germany  
IN CHINA HERGESTELLT

In caso di dubbio, si prega di contattare il nostro centro assistenza clienti, I nostri dettagli di contatto sono di seguito:

**IT**

 0039-0249471447

 clienti@aosom.it

IMPORTATO DA/Produttore/REP:  
AOSOM Italy srl  
Centro Direzionale Milanofiori  
Strada 1 Palazzo F1  
20057 Assago (MI)  
P.I.: 08567220960  
FATTO IN CINA

Si tiene alguna pregunta, comuníquese con nuestro Centro de Atención al Cliente, Nuestros datos de contacto son los siguientes:

**ES**

 0034-931294512

 atencioncliente@aosom.es

IMPORTADOR/Fabricante/REP:  
SPANISH AOSOM, S.L.  
C/ROC GROS, N°15.08550, ELS HOSTALETES DE  
BALENYÀ, SPAIN.  
B66295775  
HECHO EN CHINA

Se tiver alguma dúvida, por favor contacte o nosso Centro de Atendimento ao Cliente, Os nossos dados de contacto são os seguintes:

 0034-931294512

 info@aosom.pt.

IMPORTADOR/Fabricante/REP:  
SPANISH AOSOM, S.L.  
C.ROC GROS N.15, 08550. ELS HOSTALETES DE  
BALENYÀ  
FEITO NA CHINA



**FR**

**DONNEZ  
OU  
RECYCLEZ**



ASSOCIATION

OU



LIVRAISON

OU



DÉCHÈTERIE

Adresses sur [quefairedemesdechets.fr](http://quefairedemesdechets.fr)