

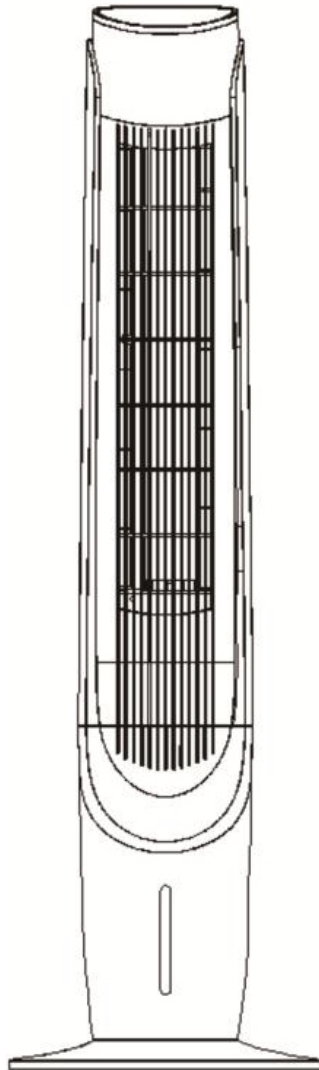

IN251000397V01_UK

824-047V71



AIR COOLER

220-240V~50-60Hz,60W

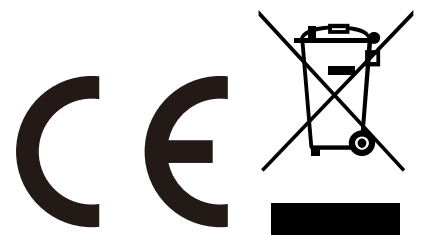

IMPORTANT, RETAIN FOR FUTURE REFERENCE: READ CAREFULLY.

READ CAREFULLY BEFORE ATTEMPTING TO ASSEMBLE, INSTALL, OPERATE OR MAINTAIN THE PRODUCT DESCRIBED. PROTECT YOURSELF AND OTHER BY OBSERVING ALL SAFETY INFORMATION. FAILURE TO COMPLY WITH INSTRUCTIONS COULD RESULT IN PERSONAL INJURY AND/OR PROPERTY DAMAGE !

IMPORTANT SAFETY INSTRUCTIONS

- Read all instructions carefully before using the FAN.
- This appliance can be used by children aged from 8 years and above and persons with reduced physical, sensory or mental capabilities or lack of experience and knowledge if they have been given supervision or instruction concerning use of the appliance in a safe way and understand the hazards involved.
- Children shall not play with the appliance.
- Cleaning and user maintenance shall not be made by children without supervision.
- If the supply cord is damaged, it must be replaced by the manufacturer, its service agent or similarly qualified persons in order to avoid a hazard.



- **Clean the water tank every three days.**
- Be aware that high humidity levels may encourage the growth of biological organisms in the environment.
- Do not permit the area around the humidifier to become damp or wet. If dampness occurs, turn the output of the humidifier down. If the humidifier output volume cannot be turned down, use the humidifier intermittently. Do not allow absorbent materials, such as carpeting, curtains, drapes, or tablecloths, to become damp.
- Unplug the appliance during filling and cleaning.
- Never leave water in the reservoir when the appliance is not in use.
- Empty and clean the humidifier before storage. Clean the humidifier before next use.
- **WARNING:** Micro-organisms that may be present in the water or in the environment where the appliance is used or stored, can grow in the water reservoir and be blown in the air causing very serious health risks when the water is not renewed and the tank is not cleaned properly every 3 days.
- Empty the tank and refill every third day. Before refilling, clean it with fresh tap water or cleaning agents if required by the manufacturer. Remove any scale, deposits, or film that has formed on the sides of the tank or on interior surfaces, and wipe all surfaces dry.
- Use this FAN only as described in this manual. Any other use not recommended by the manufacturer may cause fire, electrical shock, or injury to persons.
- Remove the package and ensure that the FAN is undamaged. In case of doubt do not use FAN and contact with your supplier.
- Do not let children play parts of package.
- Before use the FAN, check if the voltage marked on the rating label corresponds to the mains in your home.

- Extreme caution is necessary when the FAN is used by or near children or Invalids and whenever the FAN is left operating unattended.
- Avoid using extension cord as the extension cord may overheat and cause a risk of fire.
- Do not pull the power cord to disconnect with power source. Always grasp the plug to pull out.
- Do not insert any objects into the FAN as it may cause an electric shock or injure or damage to the FAN. Do not block or tamper with the FAN in any manner while it is in operation.
- Do not leave the FAN unattended. Always unplug FAN when not in use.
- This FAN is not intended for use in wet or damp locations. Never locate a FAN where it may fall into a bathtub or other water container.
- Do not use FAN outdoors.
- Disconnect the fan from the mains power when not in use, and before servicing or performing any maintenance.
- **WARNING:** The Main Power Switch and the On/Off switch should not be used as the sole means of disconnecting power. Always unplug the power cord before servicing or moving the unit.
- Keep the fan clean and maintain in good condition (use an authorized service agent).
- Use recommended parts only (non genuine parts may be dangerous, and will invalidate your warranty).
- When not in use store in a safe, dry, childproof location.
- The back housing shall not dismantle, removal will be dangerous.
- **WARNING:** To avoid danger of electric shock, unplug from outlet when not in use and before cleaning.

PARTS NAME

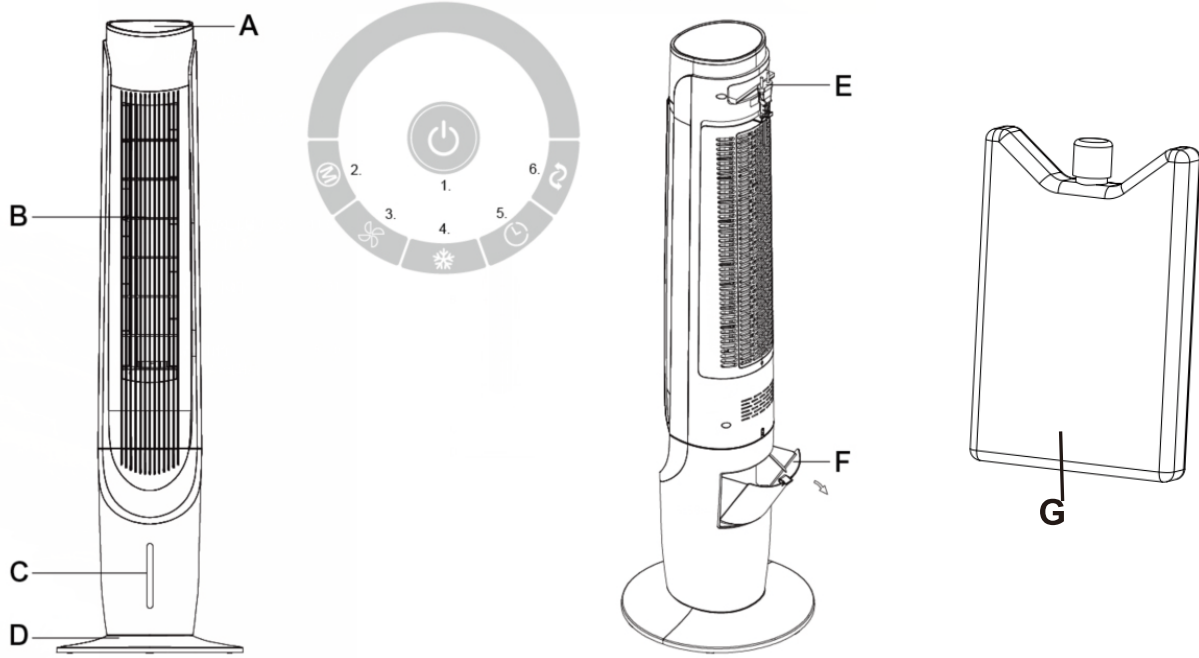

A: Control panel:

- | | | |
|------------------------|-------------------|-----------------------|
| 1: Power on/off button | 3: Speed button | 5: Timer button |
| 2: Modes button | 4: Cooling button | 6: Oscillation button |

B: Air outlet

C: Water Scale

D: Base

E: Handle

F: Water Tank

G: Ice Box

ASSEMBLY

1. Take out the two parts of the base from packing box. Then, align the centers of the two parts of the base and place them in a crossed form. Rotate one of the two bases to align its hole site and make it stuck correctly. (Fig 1)

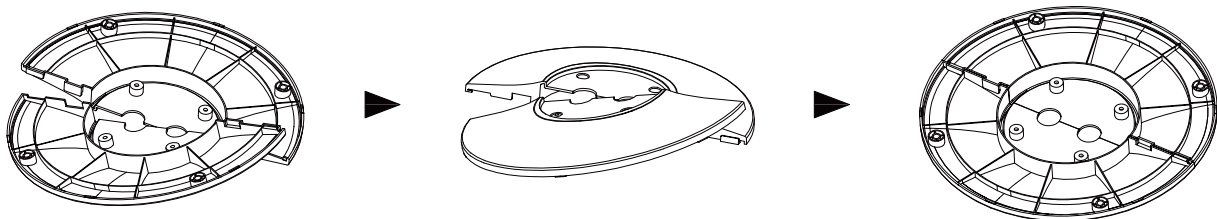

(Fig 1)

2. Fix the base on the fan body with four screws (included), with a screwdriver, wise is clockwise (Fig 2).

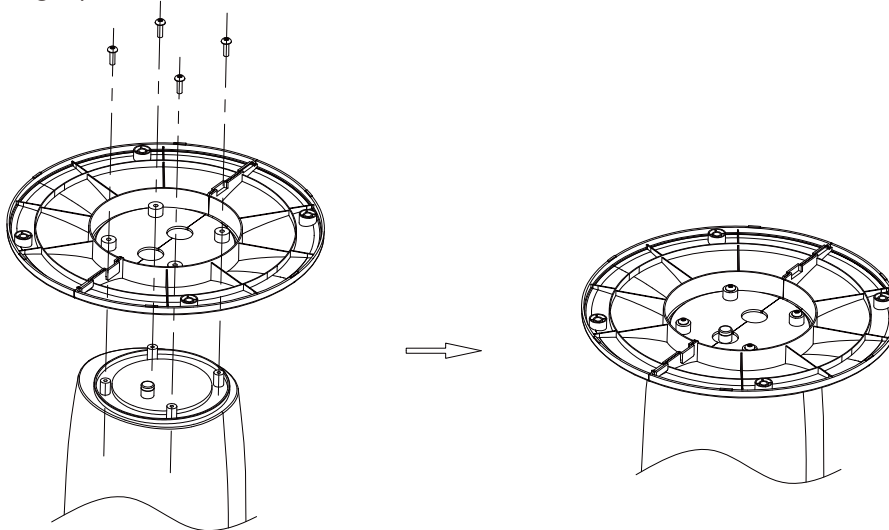

(Fig 2)

- Cable Hook:** Hanging the power cord at cable hock when the fan is not be used.(Fig 3)

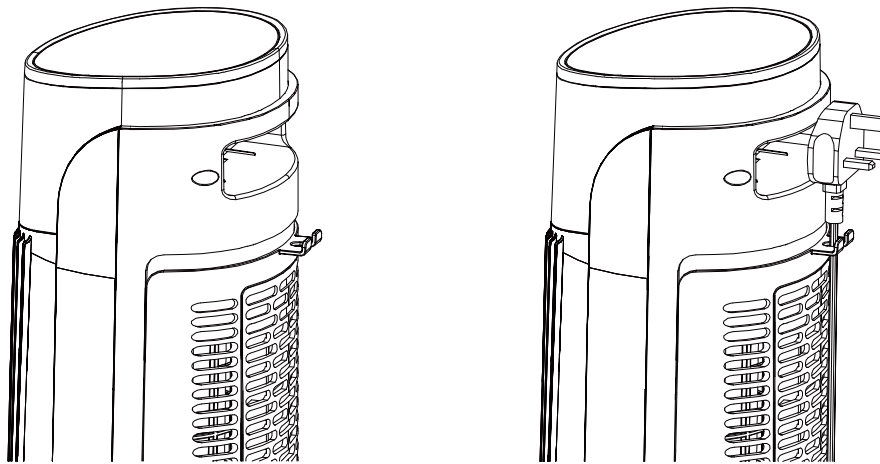

(Fig 3)

Water filling and water tank clearance



ATTENTION

1. Please be sure the plug is taken off when you fill the water or making cleaning.
2. Please clean the water that in the water tank when you do not use the product.
3. Clean Water tank: Open the water tank(Fig 4), use the brush or tool to clean the water tank, and then pull out the rubber plug to sewage disposal.(Fig 6).
4. Don't clean transducer by any metal or stiffness material or scrape it to avoid any damage.
5. Don't put acid, alkaliescent, blench scour into water tank to avoid damage.
6. Do not spray the water onto control panel and its surrounding, to avoid electrical leakage accidents.
7. When file the water, do not exceed 'MAX' level at water scale. At cooling mode, keep the water at least at 'MIN' level. (Fig 5).
8. Do not open the cover of Ice Box, to avoid its leakage. The Ice Box is environmental protection material that would storage in refrigerator and would use it repeatedly.

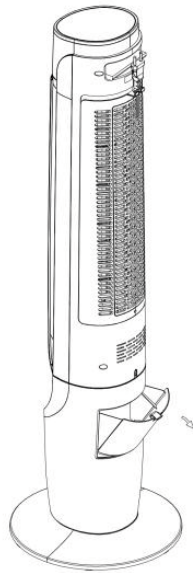

(Fig 4)



(Fig 5)

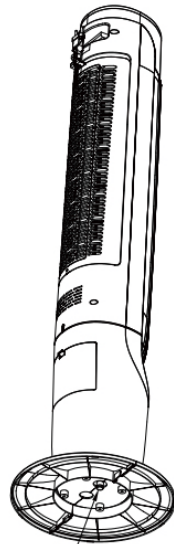

Rubber Plug (Fig 6)

Remark: One more rubber plug (spare parts) given in manual bag!

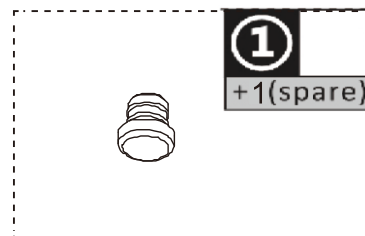
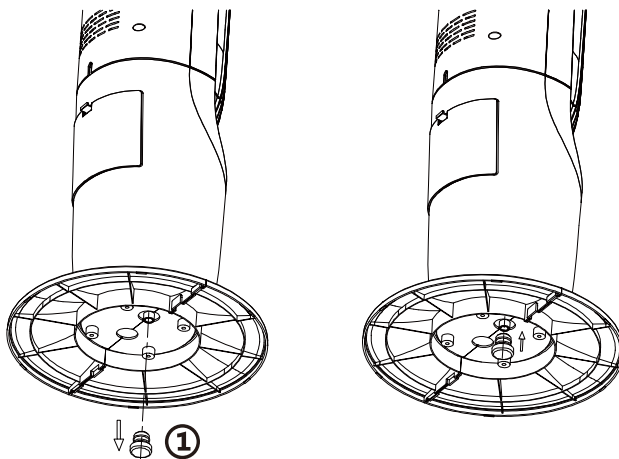

REMOTE CONTROL

1. Install 2*AAA batteries (not included) into the remote.
2. The Remote Control Power button is labeled as such(Fig 6). All the functions performed with the Remote Control work identically to the Manual Controls.

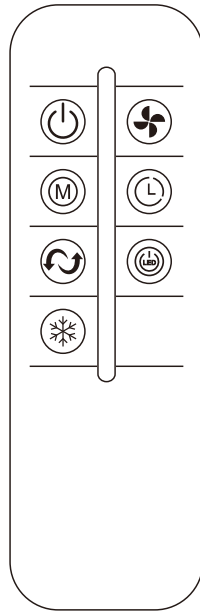



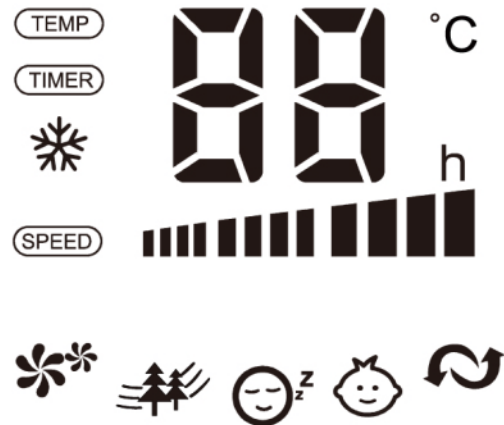



(Fig 7)



(Fig 8)



OPERATION

The FAN may be operated by the manual controls located on the FAN or by your remote control (shown in Fig 7).

1. Place the FAN on a stable flat surface. Plug the cord set into a 220-240V~ electrical outlet. Plug on the FAN, existing room temperature will be displayed at display panel.
2. **POWER**  : Turn the FAN on by pressing the 'POWER' button; Turn the FAN off by pressing the 'POWER' button again.
3. **SPEED**  : You can adjust the fan speed to the desired level: low, medium, or high by pressing 'SPEED'. The speed setting is displayed on the LED display. (Fig 8)
4. **MODE**  : Pressing the 'MODE' button will set the FAN into NORMAL, NATURAL, SLEEP and CHILD mode.
 - NORMAL Mode  : Fan will start work at any speed you set up.
 - NATURAL Mode  : Fan will start work at low speed(5s) → medium speed(5s)→ high speed(5s)→medium speed(5s), it works as per this recycle.
 - SLEEP Mode  :
 - 1) If you set the fan at high speed, fan will work at high speed for 30 mins, then transfer to medium speed at 30 mins and transfer to low speed until the fan stops working.
 - 2) If you set the mode at medium speed, fan will work at medium speed for 30 mins, then transfer to low speed until fan stop working.

3) If you set the mode at low speed, fan will work at low speed until fan stop working. The LED display will turn off if you don't control the fan in 30 seconds, touch any button to turn on the display.

- CHILD Mode  : Fan will auto. set up timer at 3 hours, oscillation function will start. And it will work at high speed for 15 minutes, transfer to medium speed at 15 minutes, then transfer to low speed until it turn off. You can turn off oscillation function by manual. The LED display will turn off if you don't control the fan in 30 seconds, touch any button to turn on the display.

5. **TIMER**  : The fan is equipped with a timer that allows you to set its length of operation from 1 hour to 12 hours. The LED display will turn off if you don't control the fan in 30 seconds, touch any button to turn on the display.
6. **OSC**  : Pressing the 'OSC' button will start and stop the oscillation function. The symbol is displayed on the LED display.
7. **COOLING**  : Press 'COOLING' button to turn on the cold air function. Press button again to turn off. If you want to operate the unit with water for better cooling, pull out the water tank and fill it up to the MAX mark at the most. Take care when doing so, to make sure, that no water enters the product, e.g. through the air inlet.

ATTENTION ABOUT ICE BOX

Then put a ice box in the water tank (the ice box needs to be frozen for more than 3 hours), and the cooling effect is better (Note: when the water tank is short of water, it is forbidden to use, please add water in time).

8. **DISPLAY**  : Can be switched off temporarily by press the LED button on the remote or by pressing and holding the SPEED button on the control panel for more than 3 seconds, the display will light up again once any control button is activated.

MAINTENANCE

1. This can only be done by an authorized service agent such as your local dealer or any agent qualified to undertake electrical repairs.
2. If the unit requires external cleaning make sure it is switched off and unplugged from the mains supply. Use a soft tissue or cloth for general cleaning. To remove more persistent dirt or grime wipe down with a cloth that has been dampened with warm soapy water. Do not use any solvents (such as thinners) as these may damage the plastic casing.

Correct Disposal of this product

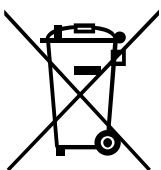

This marking indicates that this product should not be disposed with other household wastes throughout the EU. To prevent possible harm to the environment or human health from uncontrolled waste disposal, recycle it responsibly to promote the sustainable reuse of material resources. To return your used device, please use the return and collection systems or contact the retailer where the product was purchased. They can take this product for environmentally safe recycling.

TECHNICAL SPECIFICATIONS

Rated Voltage: AC220-240 V ~ 50-60 Hz

Rated Power:60W

Off mode power	P_o	[N/A]	W
Standby mode power	P_{so}	0.51	W
Power management function	[N/A]		
Time to enter automatically off mode	T_o	[N/A]	Min
Time to enter automatically standby mode	T_{so}	[N/A]	Min

UK

If you have any questions, please contact our customer care center.

Our contact details are below:



0044-800-240-4004



enquiries@mhstar.co.uk

IMPORTER ADDRESS:
 MH STAR UK LTD
 Unit 27, Perivale Park,
 Horsenden lane South
 Perivale, UB6 7RH
 MADE IN CHINA

