

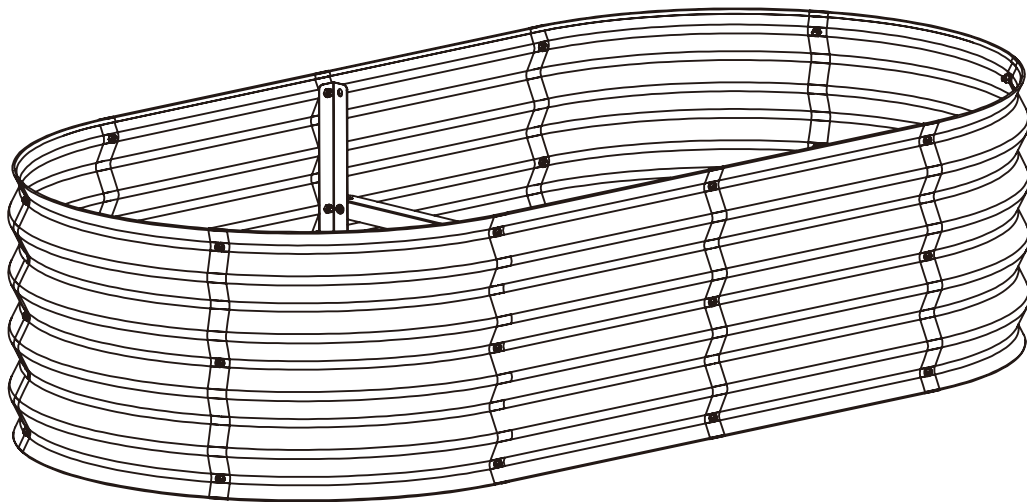

IN250900249V01\_GL

**845-981V05**



**EN\_IMPORTANT, RETAIN FOR FUTURE REFERENCE: READ CAREFULLY.**

**FR\_IMPORTANT: A LIRE ATTENTIVEMENT ET À CONSERVER POUR CONSULTATION  
ULTÉRIEURE.**

**ES\_IMPORTANTE, LEA Y GUARDE PARA FUTURAS REFERENCIAS.**

**PT\_IMPORTANTE, RETER PARA REFERÊNCIA FUTURA: LEIA ATENTAMENTE.**

**DE\_WICHTIG! SORFGFÄLTIG LESEN UND FÜR SPÄTERES NACHSCHLAGEN AUFBEWAHREN.**

**IT\_IMPORTANTE! CONSERVARE IL PRESENTE MANUALE PER FUTURO RIFERIMENTO E  
LEggerlo ATTENTAMENTE.**

**EN**

1. Pay attention to the sharp edge of some parts.
2. Wearing safety gloves, eye protection and long sleeves during the assembly to prevent injury.
3. Children and pets are not allowed entering into the construction site.

**FR**

1. Faites attention au bord tranchant de certaines parties.
2. Porter des gants de protection, des lunettes de protection et des manches longues pendant le montage pour éviter les blessures.
3. Les enfants et les animaux domestiques ne sont pas admis sur le chantier de construction.

**ES**

1. Preste atención al borde afilado de algunas partes.
2. Use guantes de seguridad, protección ocular y mangas largas durante el montaje para evitar lesiones.
3. Los niños y las mascotas no pueden ingresar al sitio de construcción.

**PT**

1. Prestar atenção à aresta afiada de algumas peças.
2. Usar luvas de segurança, protecção dos olhos e mangas compridas durante a montagem para evitar ferimentos.
3. Não é permitida a entrada de crianças e animais de estimação no abrigo durante a construção.

**DE**

1. Achten Sie auf die scharfe Kante für einige Teile.
2. Tragen Sie die Schutzhandschuhen, Augenschutz und langen Ärmeln bei der Montage zur Vermeidung von Verletzungen.
3. Die Kinder und Haustiere dürfen nicht auf die Baustelle betreten.

**IT**

1. Prestare attenzione al bordo tagliente di alcune parti.
2. Indossare guanti di sicurezza, occhiali protettivi e maniche lunghe durante l'assemblaggio per evitare lesioni.
3. Ai bambini e agli animali domestici non è consentito entrare nel cantiere.

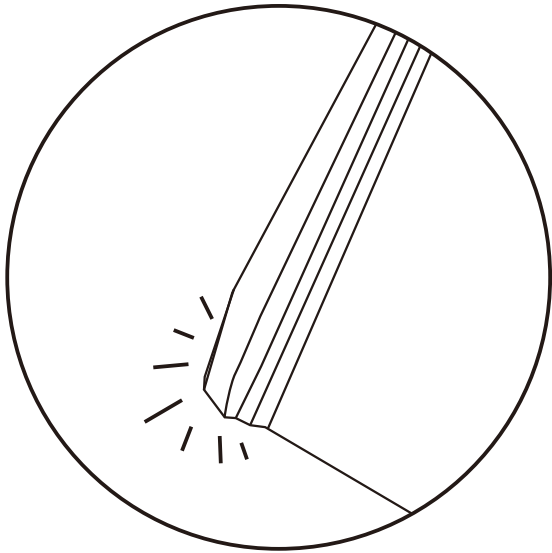

**EN\_NOTICE:** If there is slight bending on the corners

**FR\_AVIS :** En cas de légère courbure des angles

**ES\_NOTA:** Si hay una ligera flexión en las esquinas

**PT\_AVISO:** Se houver uma ligeira dobragem nas esquinas

**DE\_HINWEIS:** Wenn die Ecken leicht gebogen sind

**IT\_AVVISO:** Qualora ci fosse una leggera flessione sugli angoli

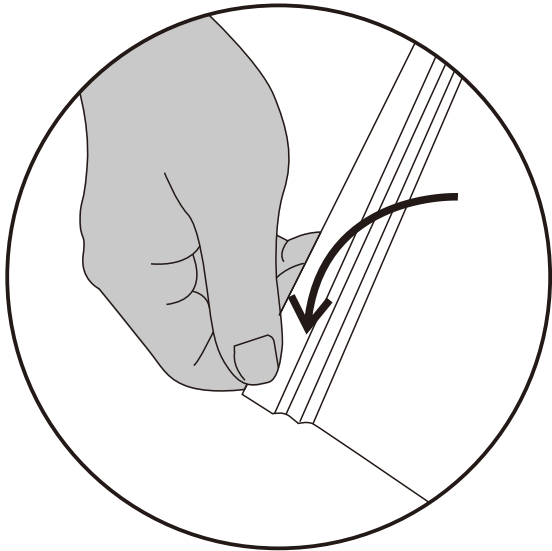

**EN\_1.** Pls wear gloves and stretch the corners slightly until they are flat

**FR\_1.** Veuillez porter des gants et exercer une légère torsion sur les bords jusqu'à ce qu'ils soient plats

**ES\_1.** Por favor, use guantes y estire las esquinas ligeramente hasta que queden planas

**PT\_1.** Utilize uma luva e estique ligeiramente os cantos até que estejam normais

**DE\_1.** Bitte tragen Sie Handschuhe und dehnen Sie die Ecken leicht, bis sie flach sind

**IT\_1.** Si prega di indossare dei guanti e di allungare leggermente gli angoli fino a quando non si sono appiattiti

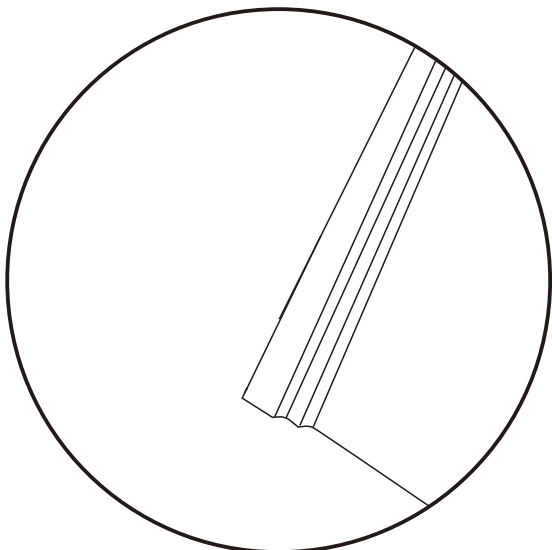

**EN\_2.** Then the sheets will be normal and there is no effect on the assembling

**FR\_2.** Les feuilles deviennent alors normales ; sans incidence sur l'assemblage.

**ES\_2.** Entonces las hojas serán normales y no hay ninguna influencia sobre el ensamblaje

**PT\_2.** Em seguida, os painéis estarão normais e não há efeito sobre a montagem

**DE\_2.** Dann sind die Platten normal und es gibt keine Auswirkungen auf den Zusammenbau

**IT\_2.** Quindi le lastre torneranno normali e non vi sarà alcun effetto sull'assemblaggio

① x6

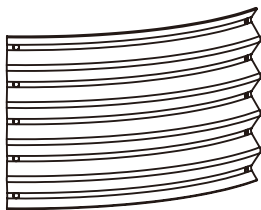

② x4

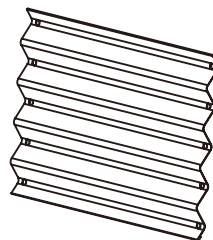

③ x2



④ x2

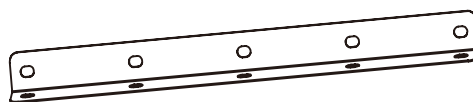

⑤ x34  
+1(spare)

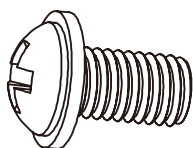

⑥ x34  
+1(spare)

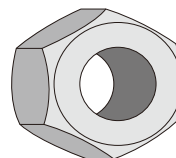

⑦ x1

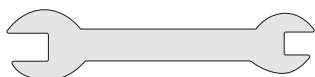

⑧ x1

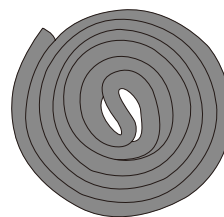

⑨ x2

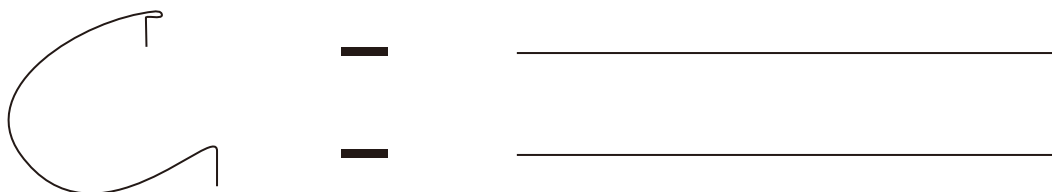

⑤ x12    ⑥ x12

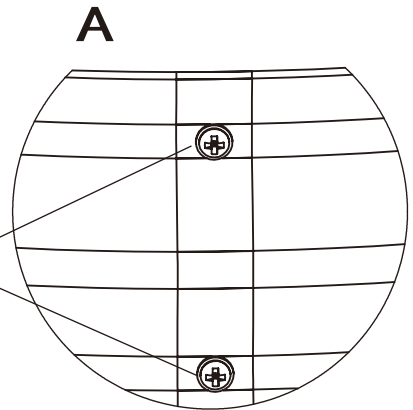
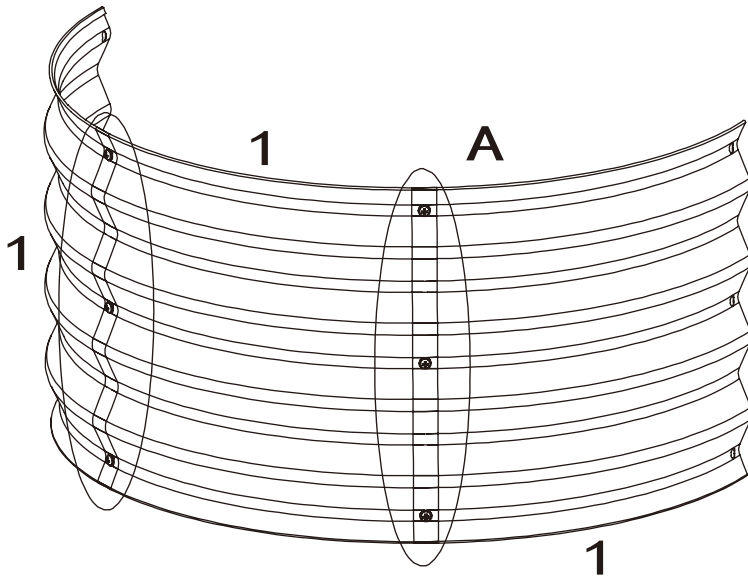

EN\_ Connect board 1 with screws.  
 FR\_ Fixez la planche 1 à l'aide de vis.  
 ES\_ Conecte la placa 1 con tornillos.  
 PT\_ Conecte a placa 1 com parafusos.  
 DE\_ Verbinden Sie Platte 1 mit Schrauben.  
 IT\_ Collegare la scheda 1 con le viti.



5/6

x2

⑤ x6    ⑥ x6

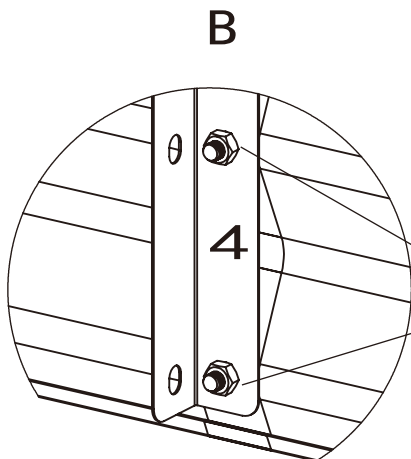
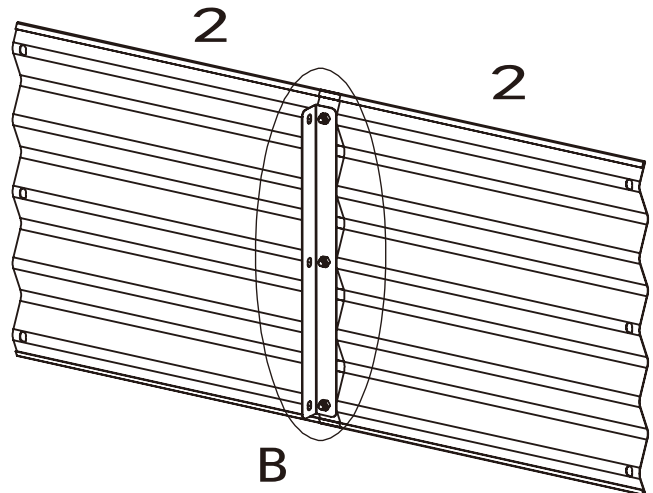

5/6

EN\_ Connect the 2nd board with screws.  
 FR\_ Fixez la deuxième planche à l'aide de vis.  
 ES\_ Conecte la segunda placa con tornillos.  
 PT\_ Conecte a segunda placa com parafusos.  
 DE\_ Verbinden Sie die zweite Platte mit Schrauben.  
 IT\_ Collegare la seconda scheda con le viti.



x2

⑤ x12    ⑥ x12

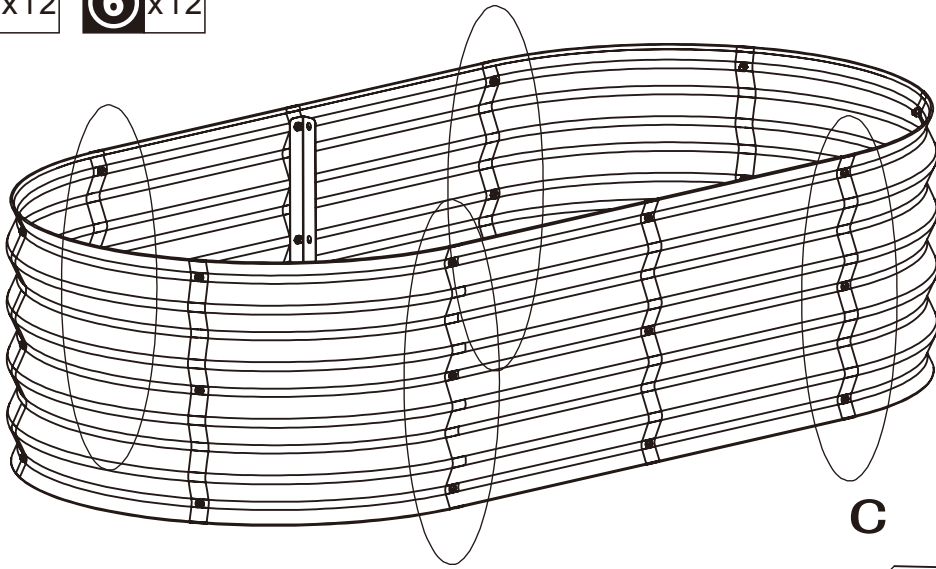

C

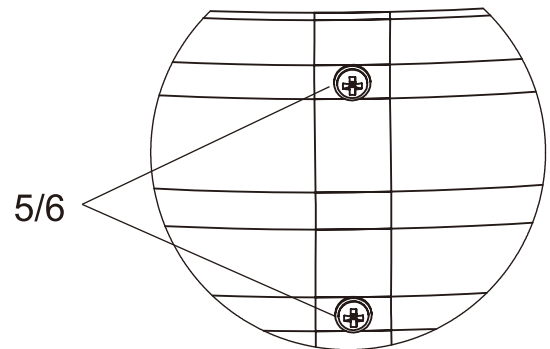

⑤ x4    ⑥ x4

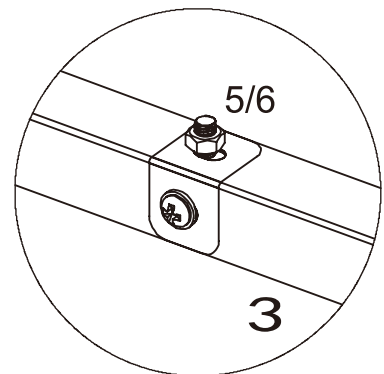
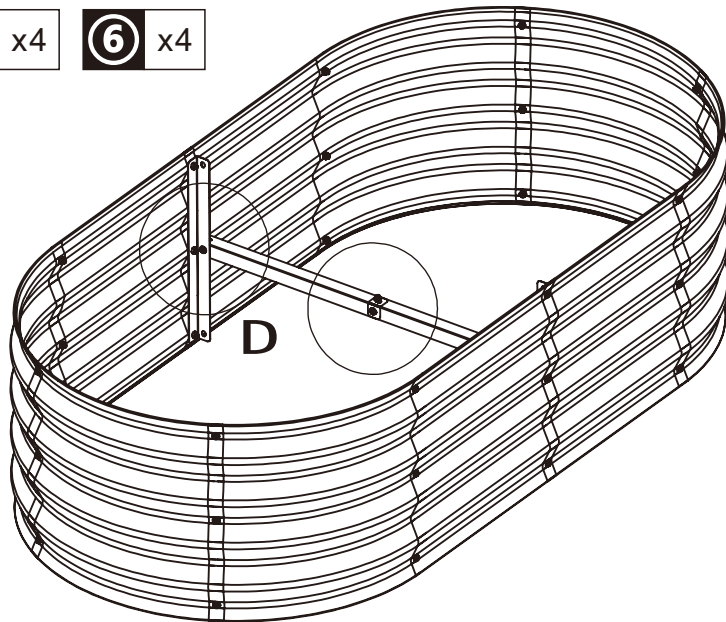

D

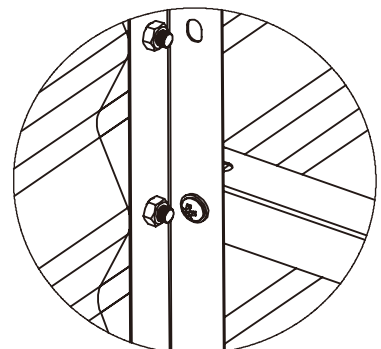

- EN\_** Connect accessory 3 to accessory 4 with screws.  
**FR\_** Fixez l'accessoire 3 à l'accessoire 4 à l'aide de vis.  
**ES\_** Conecte el accesorio 3 al accesorio 4 con tornillos.  
**PT\_** Conecte o acessório 3 ao acessório 4 com parafusos.  
**DE\_** Verbinden Sie Zubehörteil 3 mit Zubehörteil 4 mit Schrauben.  
**IT\_** Collegare l'accessorio 3 all'accessorio 4 con le viti.

8 x1

9 x2

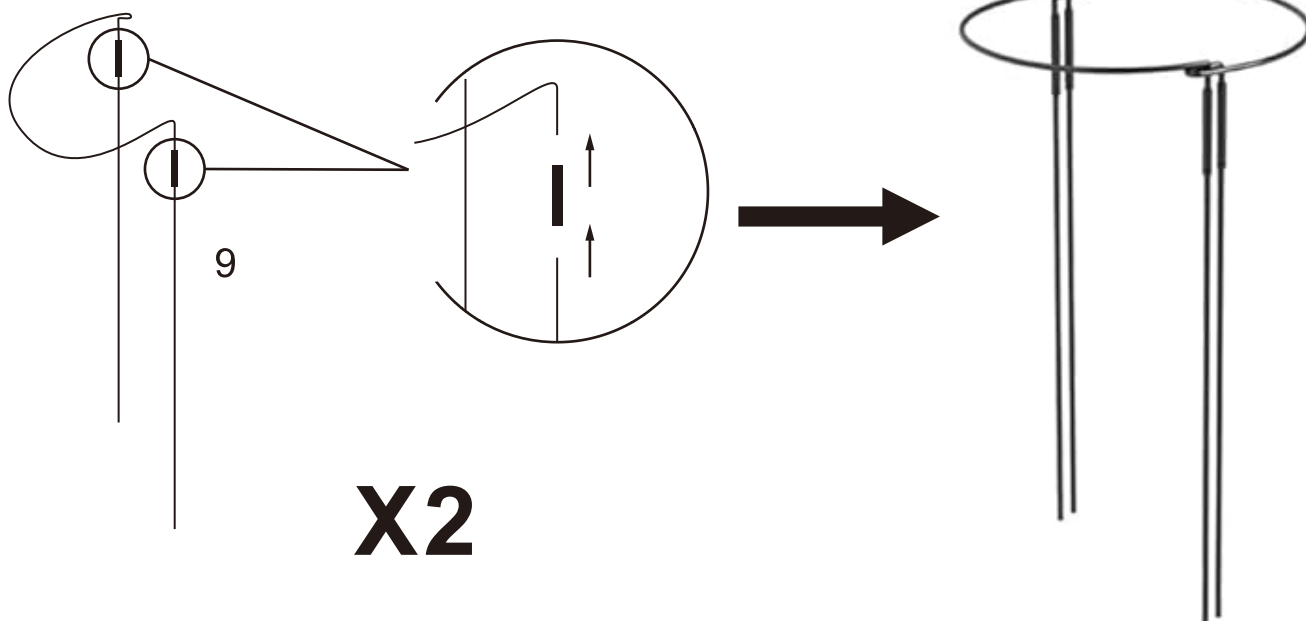
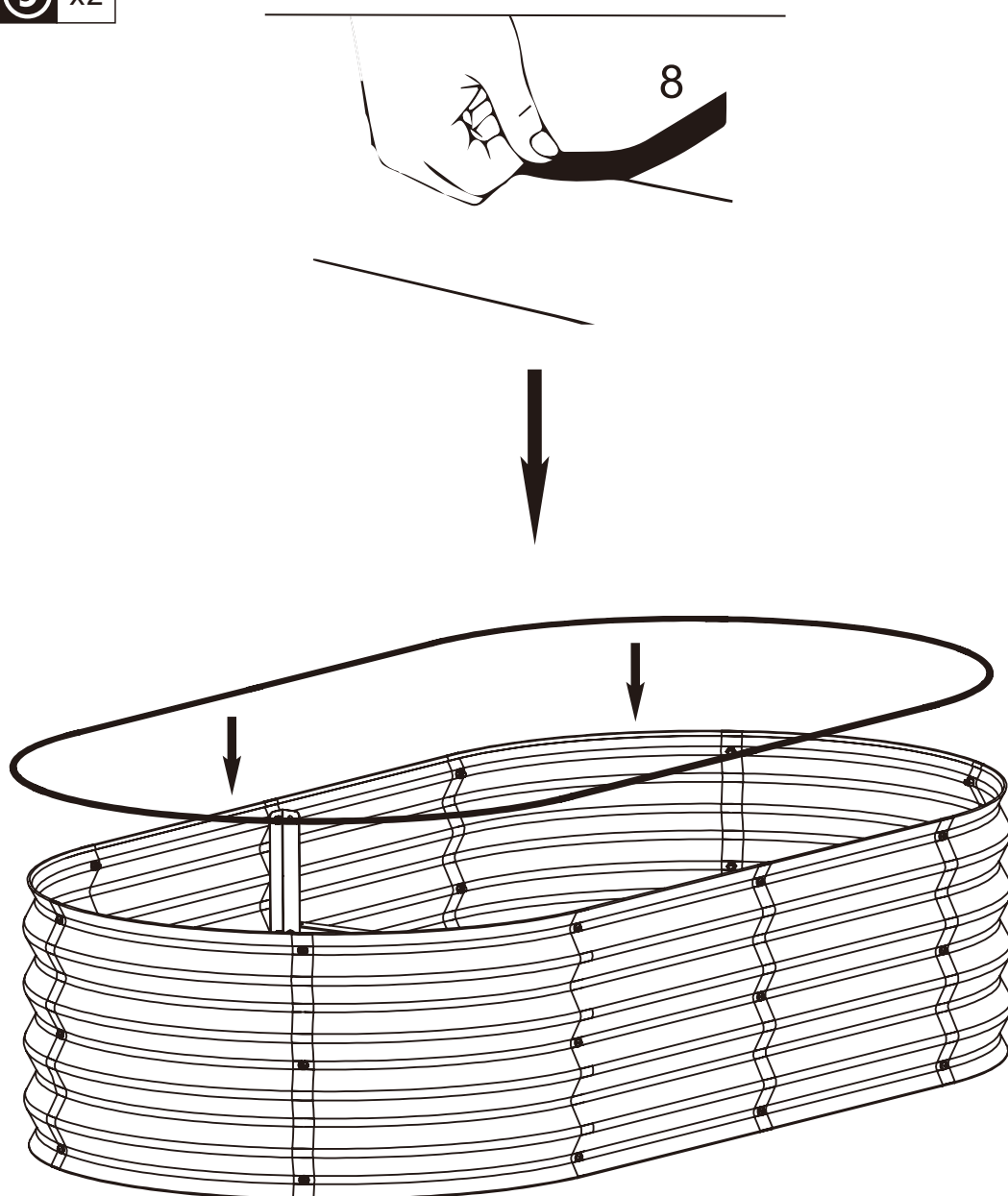

If you have any questions, please contact our customer care center, Our contact details are below:

**US**

 001-877-644-9366

 customerservice@aosom.com

Imported by Aosom LLC  
27150 SW Kinsman Rd Wilsonville, OR 97070 USA  
MADE IN CHINA

If you have any questions, please contact our customer care center, Our contact details are below:

**CA**

 416-792-6088

 customerservice@aosom.ca

Imported by Aosom Canada Inc.  
7270 Woodbine Avenue, Unit 307, Markham,  
Ontario Canada L3R 4B9  
MADE IN CHINA

Si vous avez la moindre question, veuillez contacter notre centre d'assistance à la clientèle, Nos coordonnées sont les suivantes:

 416-792-6088

 customerservice@aosom.ca

Importé par Aosom Canada Inc.  
7270 Woodbine Avenue, unité 307,  
Markham, Ontario Canada L3R 4B9  
FABRIQUÉ EN CHINE

If you have any questions, please contact our customer care center, Our contact details are below:

**UK**

 0044-800-240-4004

 enquiries@mhstar.co.uk

IMPORTER ADDRESS:  
MH STAR UK LTD  
Unit 27, Perivale Park,  
Horsenden lane South  
Perivale, UB6 7RH  
MADE IN CHINA

Si vous avez la moindre question, veuillez contacter notre centre d'assistance à la clientèle, Nos coordonnées sont les suivantes:

**FR**

 0033-1-84166106

 aosom@mhfrance.fr

Importé par/Fabricant/REP:  
MH FRANCE  
2 Rue Maurice Hartmann  
92130 Issy Les Moulineaux  
France  
FABRIQUÉ EN CHINE

Wenn Sie Fragen haben, wenden Sie sich bitte an unser Kundendienstzentrum, Unsere Kontaktdaten stehen unten:

**DE**

 0049-0(40)-87408465

 service@aosom.de

ADRESSE DES IMPORTEURE/Hersteller/REP:  
MH Handel GmbH  
Wendenstraße 309  
D-20537 Hamburg  
Germany  
IN CHINA HERGESTELLT

In caso di dubbio, si prega di contattare il nostro centro assistenza clienti, I nostri dettagli di contatto sono di seguito:

**IT**

 0039-0249471447

 clienti@aosom.it

IMPORTATO DA/Produttore/REP:  
AOSOM Italy srl  
Centro Direzionale Milanofiori  
Strada 1 Palazzo F1  
20057 Assago (MI)  
P.I.: 08567220960  
FATTO IN CINA

Si tiene alguna pregunta, comuníquese con nuestro Centro de Atención al Cliente, Nuestros datos de contacto son los siguientes:

**ES**

 0034-931294512

 atencioncliente@aosom.es

IMPORTADOR/Fabricante/REP:  
SPANISH AOSOM, S.L.  
C/ROC GROS, N°15.08550, ELS HOSTALETES DE  
BALENYÀ, SPAIN.  
B66295775  
HECHO EN CHINA

Se tiver alguma dúvida, por favor contacte o nosso Centro de Atendimento ao Cliente, Os nossos dados de contacto são os seguintes:

 0034-931294512

 info@aosom.pt.

IMPORTADOR/Fabricante/REP:  
SPANISH AOSOM, S.L.  
C.ROC GROS N.15, 08550. ELS HOSTALETES DE  
BALENYÀ  
FEITO NA CHINA



**FR**

**DONNEZ  
OU  
RECYCLEZ**



ASSOCIATION

OU



LIVRAISON

OU



DÉCHÈTERIE

Adresses sur [quefairedemesdechets.fr](http://quefairedemesdechets.fr)