

AIYAPLAY

IN250500218V01_UK

AA1-127V70



ELECTRIC SCOOTER



WARNING:
Suitable for children of 6+ years old;
Max weight: 50 kg.

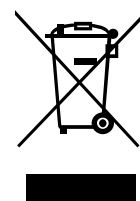
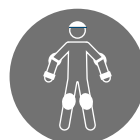

IMPORTANT, RETAIN FOR FUTURE REFERENCE: READ CAREFULLY

USER MANUAL

Catalog

I. Package Contents.....	3
II. Installation Steps.....	3
III. Safety Precautions.....	5
IV. Using the Electric Scooter.....	5
V. Charging the Battery.....	6
VI. Daily Maintenance and Care	6

I. Package Contents

1. Handlebars
2. Accessories
3. Electric Scooter
4. Charger
5. User Manual
6. Hex Wrench

II. Installation Steps

1. Insert the handlebars as illustrated and tighten the screws.

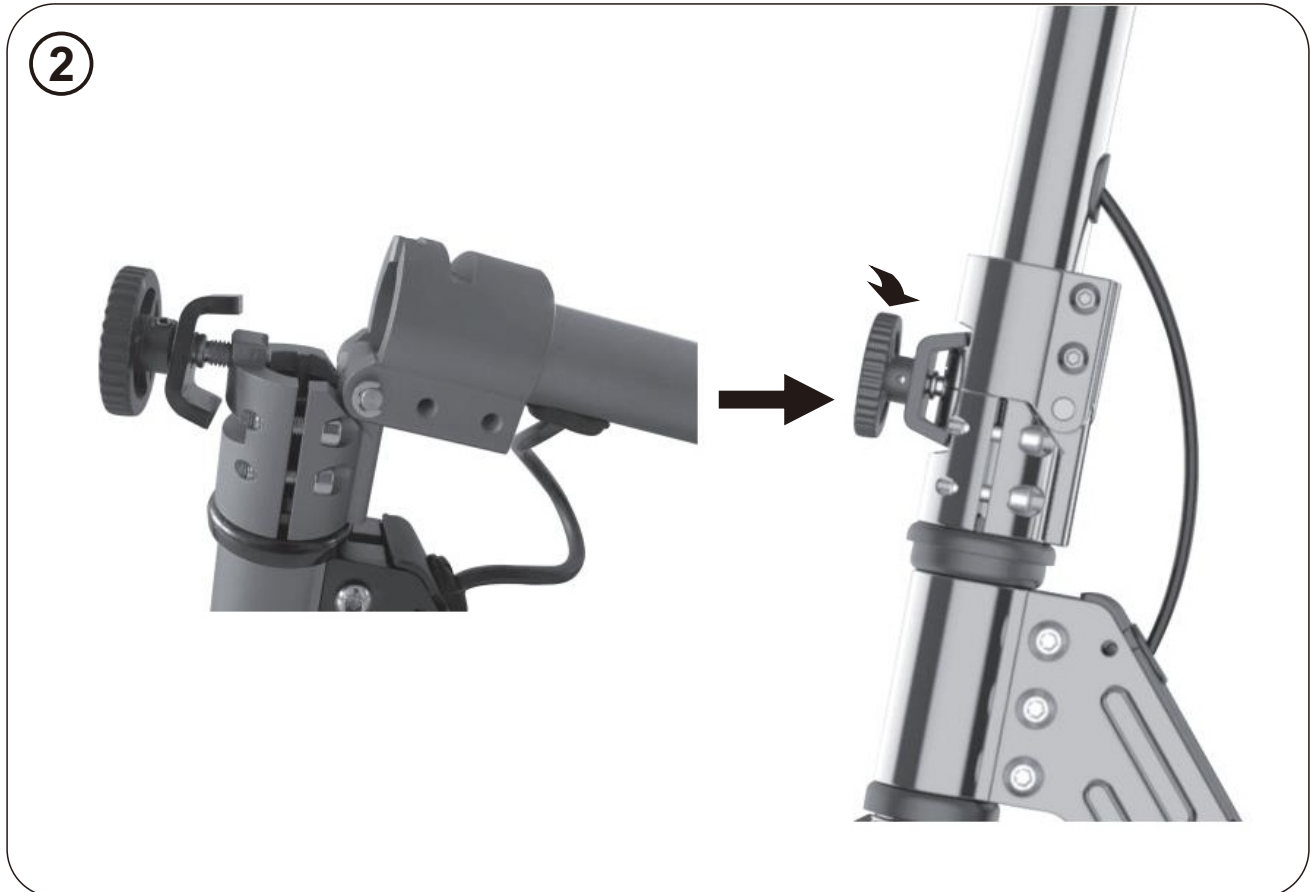

2. Perform an initial power-on check.
Function diagram



III. Safety Precautions

1. Before using the electric scooter, please ensure your child is equipped with appropriate safety gear, such as a helmet, wrist guards, and knee pads.
2. Avoid using the electric scooter on wet, slippery surfaces, steep slopes, or in complex traffic environments.
3. Do not continue to use the scooter when the battery is low to avoid battery over-discharge.
4. Do not press the throttle while walking with the scooter.
5. Avoid obstacles while riding.
6. Do not hang heavy items on the handlebars.
7. Do not ride with one foot.
8. Do not drive on public roads, motor ways, or highways.
9. Do not make substantial turns of the handlebars while driving at high speed.
10. Do not drive in standing water.
11. Do not allow more than one person to ride the scooter at a time or carry a child while riding.
12. Do not step on the folding switch while riding.
13. The wheel motor may become hot during operation, avoid touching.
14. Do not drive without holding the handlebars. Do not drive with one hand.
15. Do not ride the scooter up or down steps or jump obstacles.
16. Hold the handlebars tightly with both hands, otherwise, you may lose balance or fall and seriously injure yourself.
17. Scooter not approved for use on public roads.
18. Use is to be considered exclusively for private areas.
19. Any other use will be subject to penalties provided by the current Highway Code.

IV. Using the Electric Scooter

1. Ensure the scooter's battery is fully charged.
2. Power on the scooter and check the battery indicator light. If the battery is low, please charge it immediately.
3. Stand on the scooter with one foot and use the other foot to push off and start moving.
4. Place the other foot on the scooter, and keep both feet stable. Once balanced, gently press the throttle on the right handle to accelerate. Please note that for your safety, the motor will not start until the scooter reaches 3km/h.
5. Release the throttle to slow down. For emergency braking, quickly pull the brake lever
6. When turning, slightly lean your body weight towards the direction of the turn and slowly turn the handlebars.
7. When your child is done using the scooter, turn off the power switch on both the scooter and the controller.

V. Charging the Battery

1. Plug the charger's power cord into the power socket.
2. Insert the charger's charging plug into the charging port on the scooter and controller.
3. When the charger's indicator light turns from red to green, the battery is fully charged.
4. Do not use other models or brands of batteries, as it may pose a safety risk.
5. Avoid touching the battery contacts, disassembling, or puncturing the casing. Avoid metal objects contacting the battery contacts to prevent short circuits. This could cause damage to the battery or injury.
6. Improper disposal of used batteries can severely pollute the environment. Discard the battery pack according to local regulations. Do not dispose of this battery arbitrarily, let's protect our environment together.
7. Do not place the battery in a high temperature above 50°C or a low temperature below -20°C environment (for example, do not leave the scooter or its battery in a car exposed to the sun in summer), and do not throw the battery into fire, as it may lead to battery failure, overheating, or even fire risk.
8. Only use the original charger for charging, otherwise, there is a risk of damage or fire.
9. Do not disassemble the charger casing by yourself. Avoid touching the interface contacts with metal objects when powered on, as it may cause electric shock or charger damage.

VI. Daily Maintenance and Care

Cleaning and Storage

Wipe the main frame clean with a soft damp cloth. If there are stubborn stains, apply toothpaste and scrub repeatedly with a toothbrush, then clean with a soft damp cloth. If there are scratches on the plastic parts of the body, they can be polished with fine sandpaper.

Tips: Do not use alcohol, gasoline, kerosene, or other corrosive, volatile solvents to clean your scooter. These substances may damage the appearance and internal structure of the scooter. Do not use pressure washers or hose sprays.

Warning: Before cleaning, make sure the scooter is turned off and the charging cable has been unplugged, and the rubber cap of the charging port is tightly fastened, otherwise, it may damage the electronic components. When not in use, store the scooter in a cool, dry place. Do not leave the scooter outdoors for extended periods. Sun exposure and extreme temperature conditions (overheating and overcooling) will accelerate the aging of plastic parts and may reduce battery life.

Battery Maintenance

When storing or charging the battery, do not exceed the specified temperature limit (please refer to the model parameter table). Do not puncture the battery. Please refer to the laws and regulations in your area regarding battery recycling and/or disposal.

Maintaining a well-maintained battery can keep it running well even after many miles of travel. Please charge the battery after each ride and avoid completely depleting the battery. At normal temperatures of 22°C, the battery's endurance and performance are optimal. However, when used in conditions below 0°C, the battery's endurance and performance may decline. Generally speaking, the same battery at -20°C has only half the endurance and performance of 22°C. The battery's endurance will recover as the temperature rises.

Model identifie		
Input voltage	100-240 ~	V
Input AC frequency	50	Hz
Output voltage	--- 25.2	V
Output current	1	A
Output power	25.2	W
Average active efficiency	86.42	%
Efficiency at low load (10 %)	82.53	%
No-load power consumption	0.3	W

If you have any questions, please contact our customer care centre.
Our contact details are below:



0044-800-240-4004



enquiries@mhstar.co.uk

IMPORTER ADDRESS:
MH STAR UK LTD
Unit 27, Perivale Park,
Horsenden lane South
Perivale, UB6 7RH
MADE IN CHINA

