

# PawHut

IN251100544V01\_GL

D00-222V00\_D00-222V01\_D00-222V02

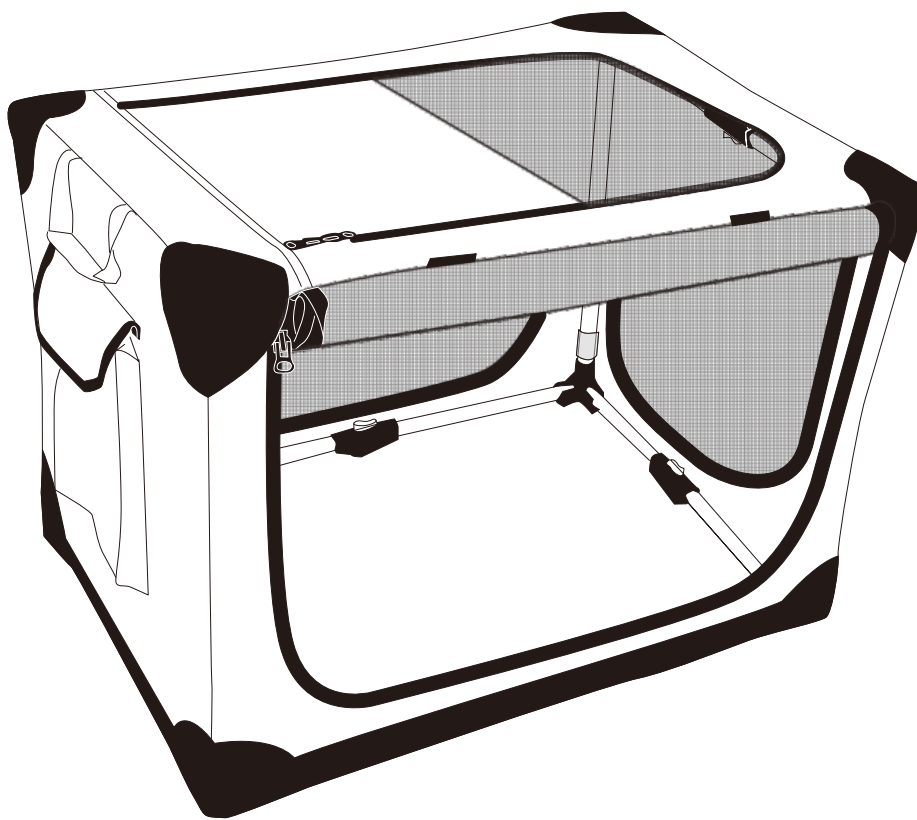

**EN\_IMPORTANT, RETAIN FOR FUTURE REFERENCE: READ CAREFULLY.**

**FR\_IMPORTANT: A LIRE ATTENTIVEMENT ET À CONSERVER POUR CONSULTATION  
ULTÉRIEURE.**

**ES\_IMPORTANTE, LEA Y GUARDE PARA FUTURAS REFERENCIAS.**

**PT\_IMPORTANTE, RETER PARA REFERÊNCIA FUTURA: LEIA ATENTAMENTE.**

**DE\_WICHTIG! SORGFÄLTIG LESEN UND FÜR SPÄTERES NACHSCHLAGEN AUFBEWAHREN.**

**IT\_IMPORTANTE! CONSERVARE IL PRESENTE MANUALE PER FUTURO RIFERIMENTO E  
LEggerlo ATTENTAMENTE.**



MANUAL FOR FOLDING PET CRATE

How to Unfold the Pet Crate ?

1. Lay the pet crate flat on the ground and expand it. See Fig 3.1.
2. Pull the top joint straight up until you hear a clicking sound. See Fig 3.2.1. Continue pulling the remaining joints up.

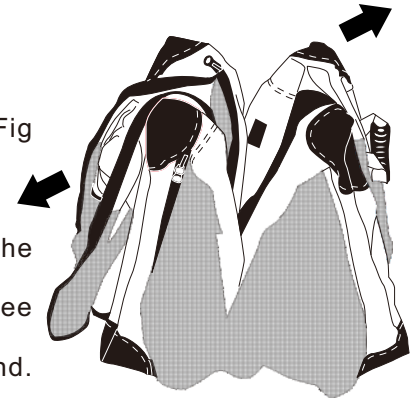

Fig 3.1

Note:

- 1) If the last joint (too tight) cannot be pulled up, please rotate the crate 180° and press. See Fig 3.2.2
  - 2) If the joint does not open, manually push the red button forward. See Fig 3.2.3
  3. Press the bottom joint straight down until you hear a clicking sound. See Fig 3.3
- Note: If the joint does not open, manually push the red button forward. See Fig 3.2.3
4. Lay the pad flat on the bottom of the crate and secure it with the Nylon buckle.
  5. Your pet crate is now ready to use!

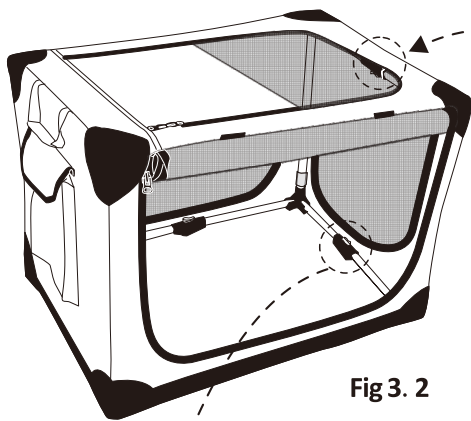

Fig 3.2

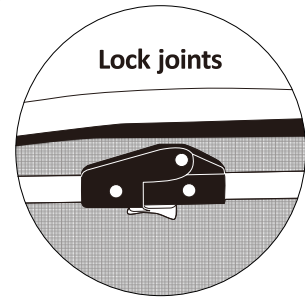
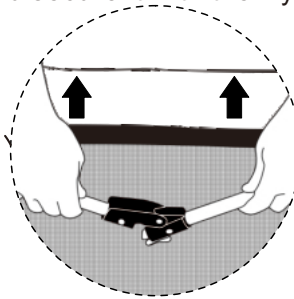

Fig 3.2.1

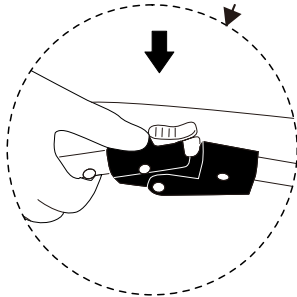

Fig 3.3

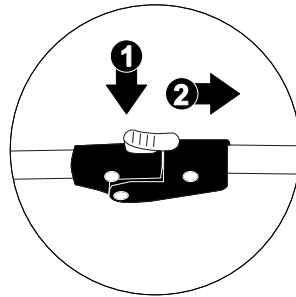

Fig 3.2.3

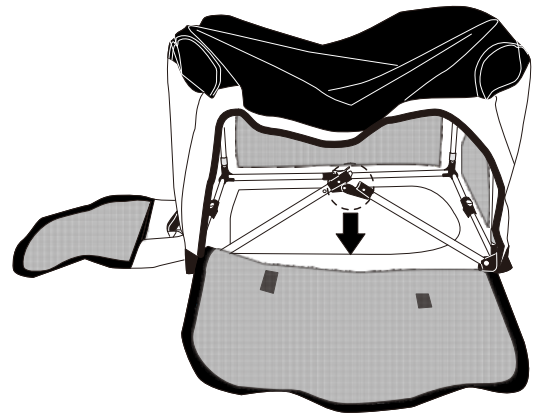

Fig 3.2.2

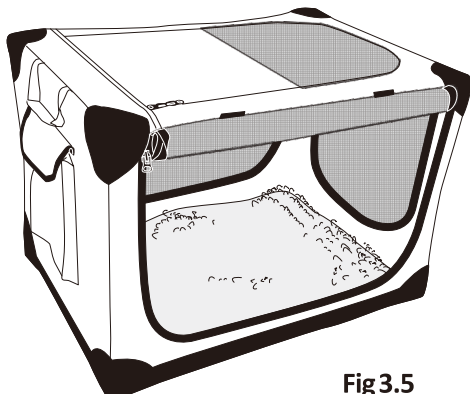

Fig 3.5

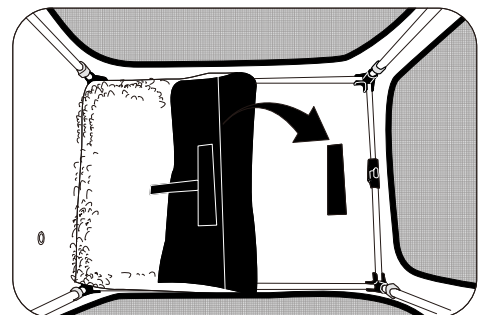

Fig 3.4

**How to Fold the Pet Crate ?**

1. Remove the pad from the crate. See Fig 4.1
2. Gently lift the top joint, slide the switch in the direction of the arrow, and press the joint down. See Fig 4.2.1.

Continue lifting the remaining joints.

3. Slide the switch on the bottom joint in the direction of the arrow, then pull up the joint. See Fig 4.2.2
4. Fold the crate diagonally. See Fig 4.3
5. Place the folded crate on the pet pad. And wrap the crate with the pad and secure it using the Nylon buckle. See Fig 4.4
6. Place everything into the storage bag. Your pet crate is now neatly stored! See Fig 4.5

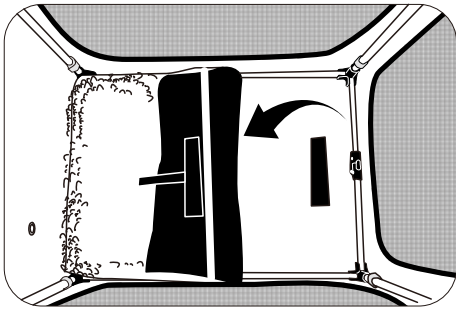
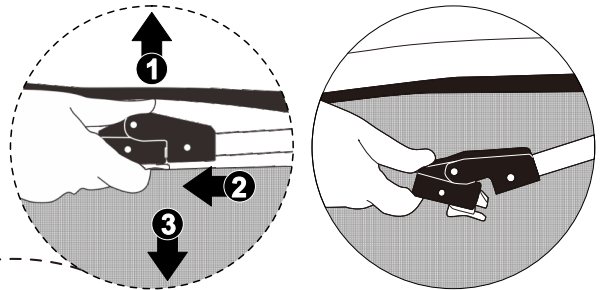
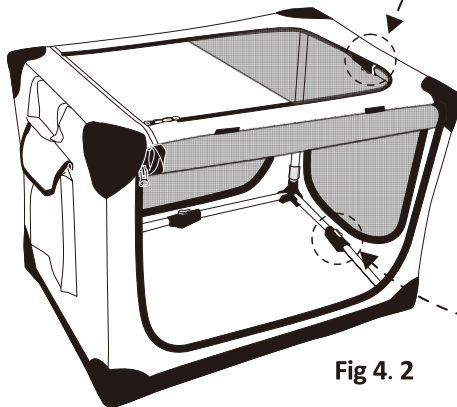
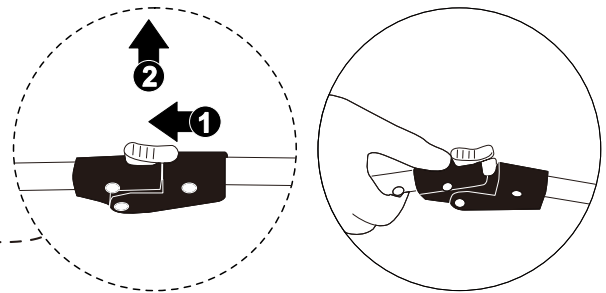
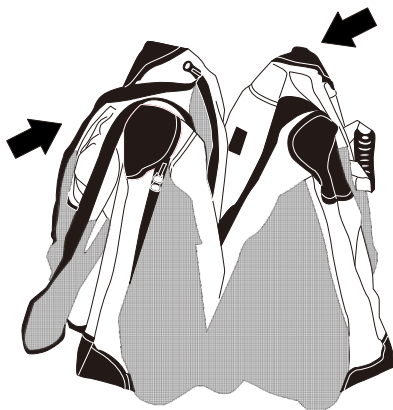
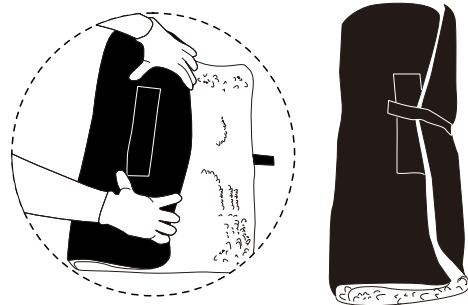
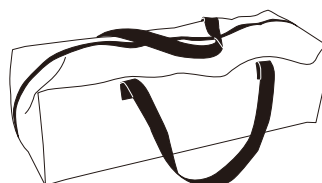
**Fig 4.1****Fig 4.2.1****Fig 4.2****Fig 4.2.2****Fig 4.3****Fig 4.4****Fig 4.5**



## MANUEL D'UTILISATION DE LA CAGE PLIABLE POUR ANIMAUX

Comment déplier la cage pour animaux ?

1. Posez la cage à plat sur le sol et dépliez-la. Voir Fig. 3.1.
2. Tirez le joint supérieur vers le haut jusqu'à ce que vous entendiez un clic. Voir Fig. 3.2.1. Continuez à tirer les joints restants vers le haut.

Remarque :

- 1) Si le dernier joint (trop serré) ne peut pas être tiré vers le haut, veuillez faire pivoter la cage de 180° et appuyer. Voir fig. 3.2.2.
- 2) Si le joint ne s'ouvre pas, poussez manuellement le bouton rouge vers l'avant. Voir fig. 3.2.3.
3. Appuyez sur le joint inférieur vers le bas jusqu'à ce que vous entendiez un clic. Voir fig. 3.3.

Remarque : si le joint ne s'ouvre pas, poussez manuellement le bouton rouge vers l'avant. Voir Fig. 3.2.3.

4. Posez le coussin à plat au fond de la cage et fixez-le à l'aide de la boucle en nylon.
5. Votre cage pour animaux est maintenant prête à l'emploi !

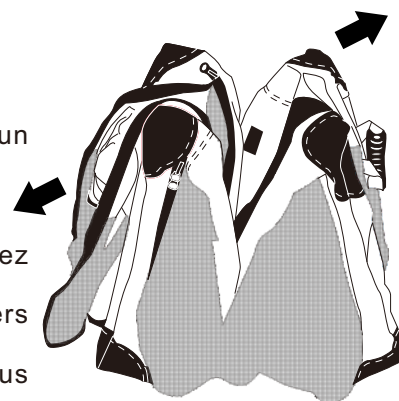

Fig 3.1

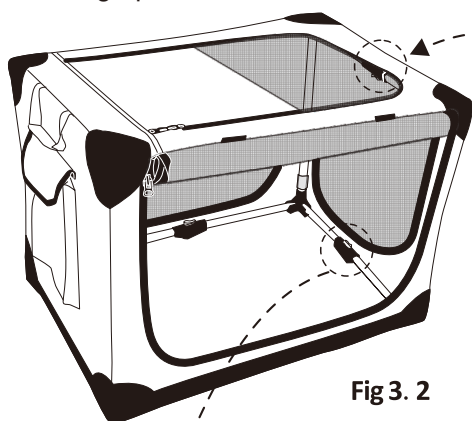

Fig 3.2

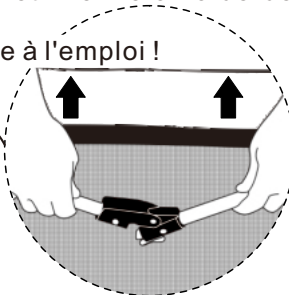

Fig 3.2.1

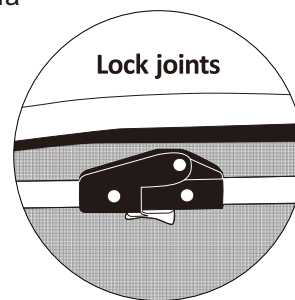

Fig 3.2.2

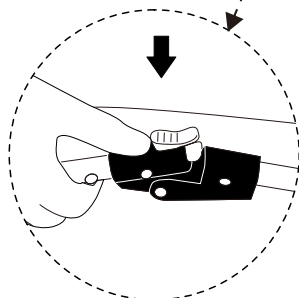

Fig 3.3

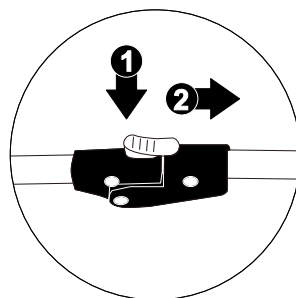

Fig 3.2.3

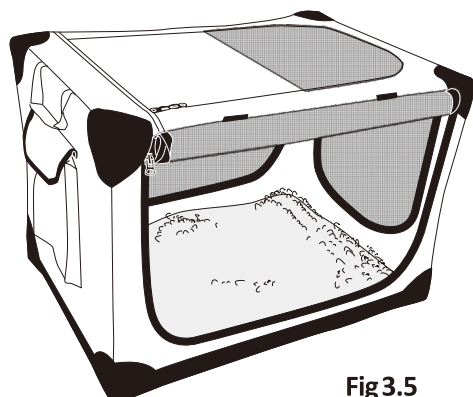
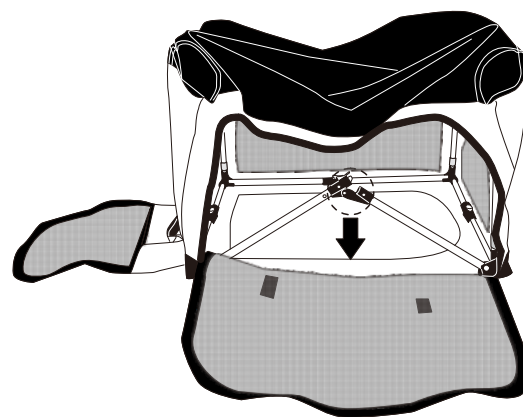

Fig 3.5

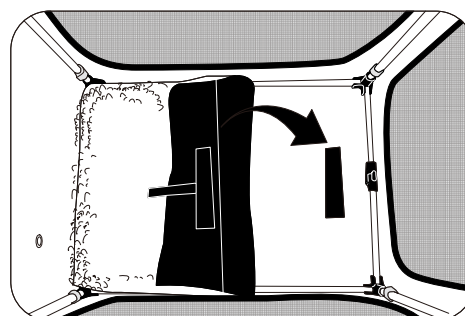

Fig 3.4

Comment plier la cage pour animaux ?

1. Retirez le coussin de la cage. Voir Fig. 4.1

2. Soulevez délicatement le joint supérieur, faites glisser le loquet dans le sens de la flèche et appuyez sur le joint. Voir Fig. 4.2.1.

Continuez à soulever les joints restants.

3. Faites glisser le loquet du joint inférieur dans le sens de la flèche, puis soulevez le joint. Voir Fig. 4.2.2

4. Pliez la cage en diagonale. Voir fig. 4.3

5. Placez la cage pliée sur le coussin pour animaux. Enveloppez la cage avec le coussin et fixez-la à l'aide de la boucle en nylon. Voir fig. 4.4

6. Placez le tout dans le sac de rangement. Votre cage pour animaux est désormais rangée de manière ordonnée ! Voir fig. 4.5

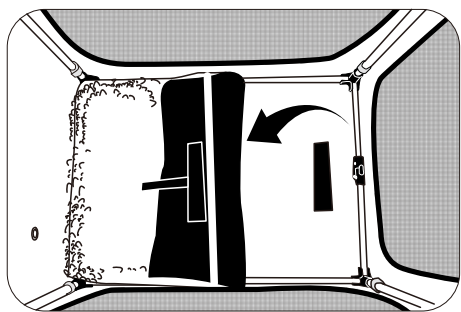

Fig 4.1

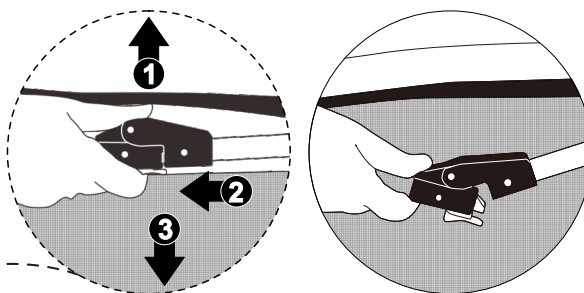

Fig 4.2.1

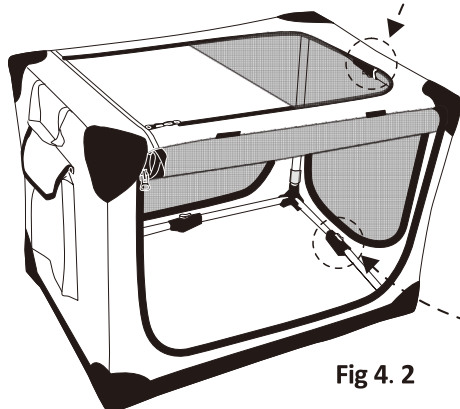

Fig 4.2

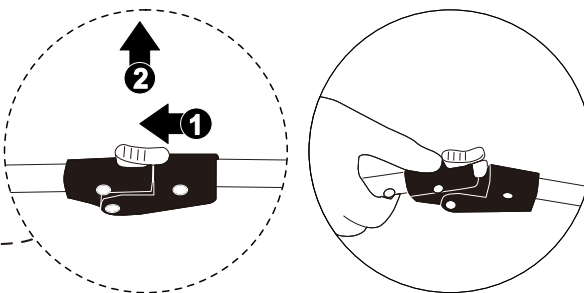

Fig 4.2.2

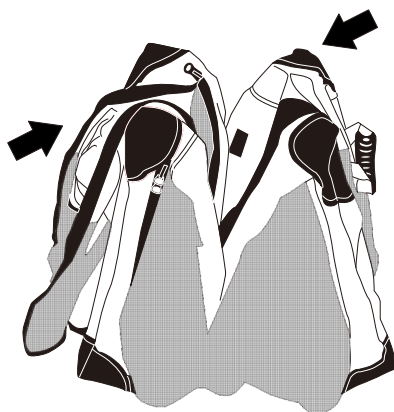

Fig 4.3

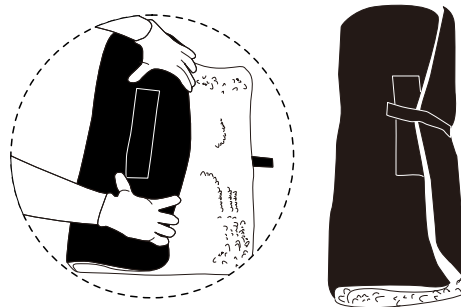

Fig 4.4

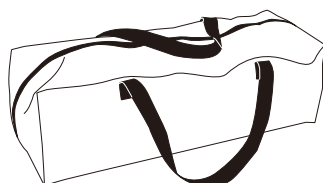

Fig 4.5



MANUAL PARA PLIEGAR LA JAULA PARA MASCOTAS

¿Cómo desplegar la jaula para mascotas?

1. Coloque la jaula para mascotas en el suelo y expándala. Véase la figura 3.1.
2. Tire de la junta superior hacia arriba hasta que oiga un clic. Véase la figura 3.2.1. Continúe tirando de las juntas restantes hacia arriba.

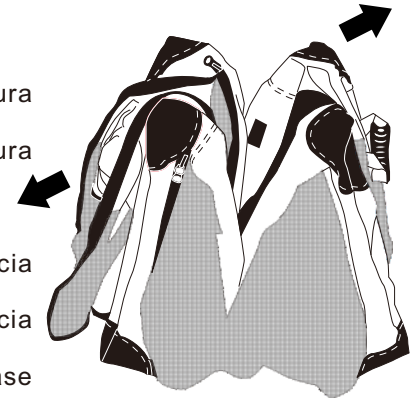

Fig 3.1

Nota:

- 1) Si la última articulación (demasiado apretada) no se puede tirar hacia arriba, gire la jaula 180° y presione. Véase la figura 3.2.2.
- 2) Si la articulación no se abre, empuje manualmente el botón rojo hacia adelante. Véase la figura 3.2.3.
3. Presione la articulación inferior hacia abajo hasta que oiga un clic. Véase la figura 3.3.

Nota: Si la junta no se abre, empuje manualmente el botón rojo hacia delante. Véase la figura 3.2.3.

4. Coloque la almohadilla en la parte inferior de la jaula y fijela con la hebilla de nailon.

5. ¡Su jaula para mascotas ya está lista para usar!

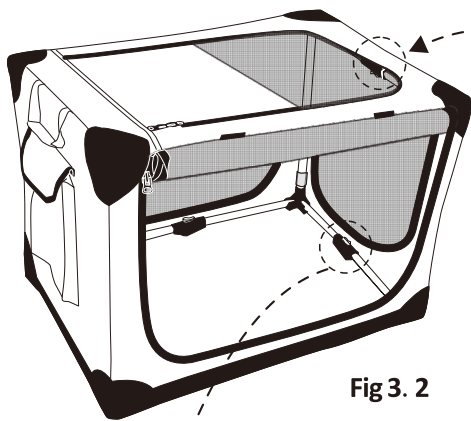

Fig 3.2

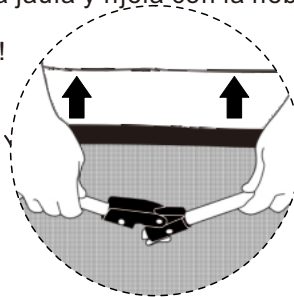

Fig 3.2.1

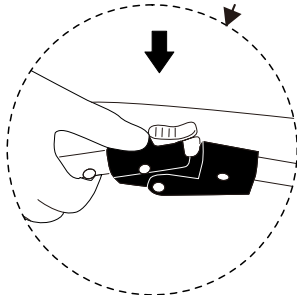
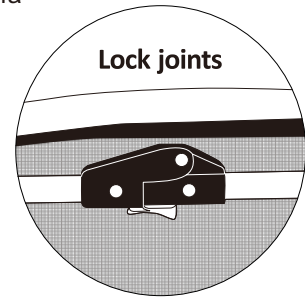

Fig 3.3

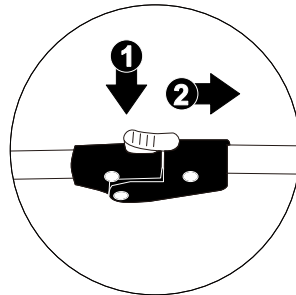

Fig 3.2.3

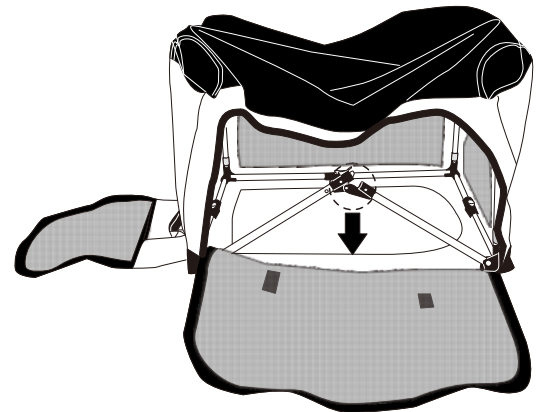

Fig 3.2.2

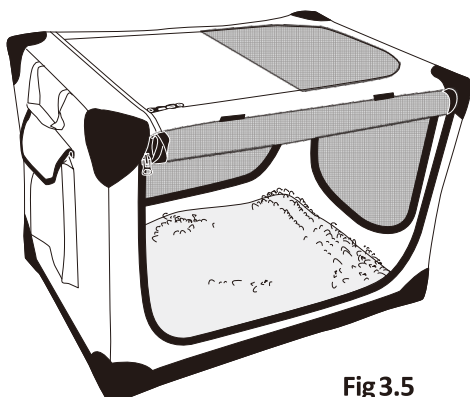

Fig 3.5

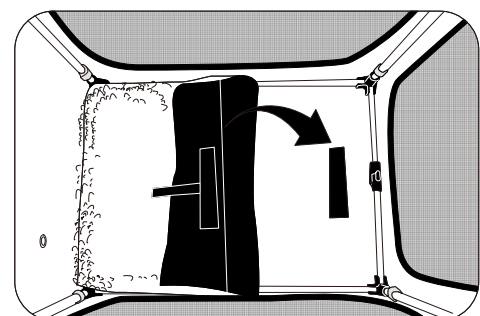

Fig 3.4

**¿Cómo plegar la jaula para mascotas?**

1. Retire la almohadilla de la jaula. Véase la figura 4.1.
2. Levante suavemente la junta superior, deslice el interruptor en la dirección de la flecha y presione la junta hacia abajo. Véase la figura 4.2.1.

Continúe levantando las juntas restantes.

3. Deslice el interruptor de la junta inferior en la dirección de la flecha y, a continuación, tire de la junta hacia arriba. Véase la figura 4.2.2.
4. Pliegue la jaula en diagonal. Véase la figura 4.3.
5. Coloque la jaula plegada sobre la almohadilla para mascotas. Envuelva la jaula con la almohadilla y fíjela con la hebilla de nailon. Véase la figura 4.4.
6. Guarde todo en la bolsa de almacenamiento. ¡Su jaula para mascotas ya está perfectamente guardada! Véase la figura 4.5.

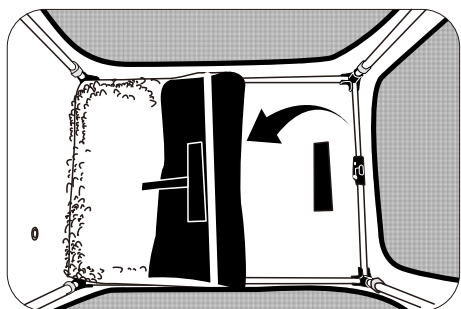

**Fig 4.1**

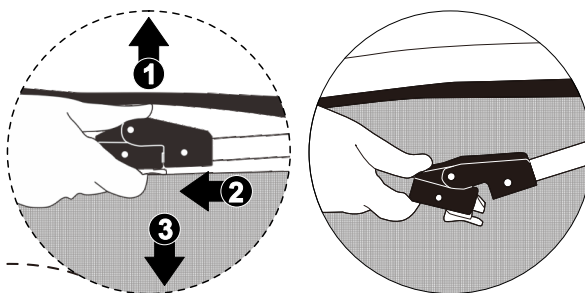

**Fig 4.2.1**

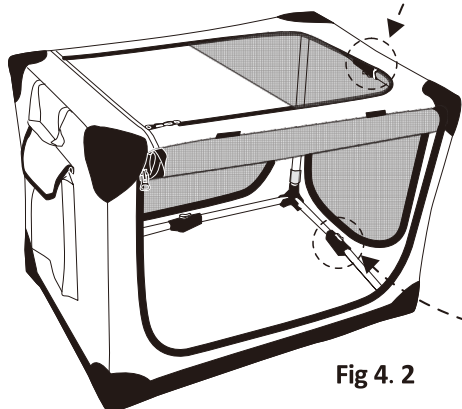

**Fig 4.2**

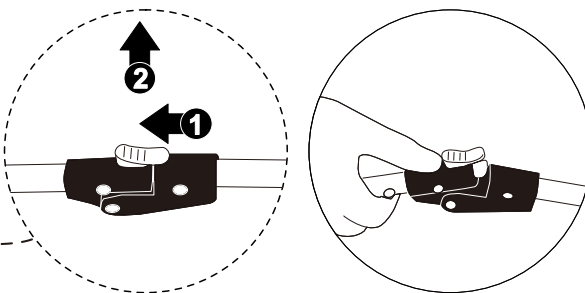

**Fig 4.2.2**

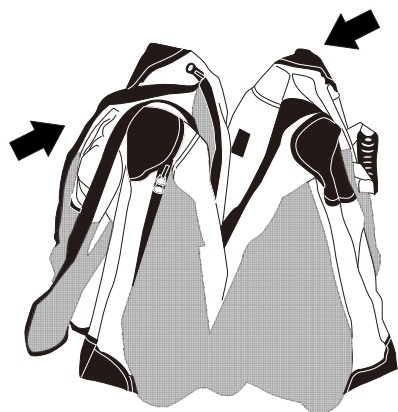

**Fig 4.3**

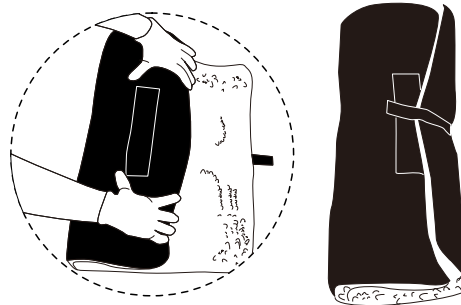

**Fig 4.4**

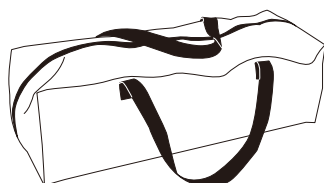

**Fig 4.5**



ANLEITUNG ZUM ZUSAMMENKLAPPEN DER TIERTRANSPORTBOX

Wie klappt man die Tiertransportbox auf?

1. Legen Sie die Tiertransportbox flach auf den Boden und klappen Sie sie auf. Siehe Abb. 3.1.
2. Ziehen Sie das obere Gelenk gerade nach oben, bis Sie ein Klicken hören. Siehe Abb. 3.2.1. Ziehen Sie die restlichen Gelenke weiter nach oben.

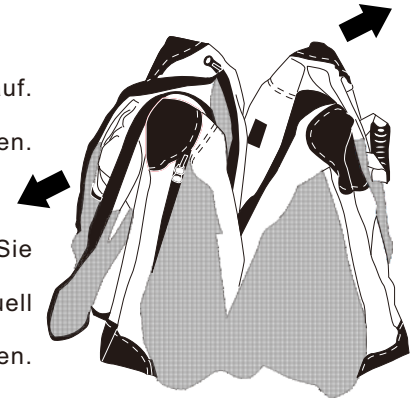

Fig 3.1

Hinweis:

- 1) Wenn sich das letzte Gelenk (zu fest) nicht nach oben ziehen lässt, drehen Sie die Transportbox bitte um 180° und drücken Sie darauf. Siehe Abb. 3.2.2.
- 2) Wenn sich das Gelenk nicht öffnen lässt, drücken Sie den roten Knopf manuell nach vorne. Siehe Abb. 3.2.3.
3. Drücken Sie das untere Gelenk gerade nach unten, bis Sie ein Klicken hören. Siehe Abb. 3.3.

Hinweis: Wenn sich die Verbindung nicht öffnen lässt, drücken Sie den roten Knopf manuell nach vorne. Siehe Abb. 3.2.3.

4. Legen Sie die Unterlage flach auf den Boden der Transportbox und befestigen Sie sie mit der Nylonschnalle.
5. Ihre Transportbox für Haustiere ist nun einsatzbereit!

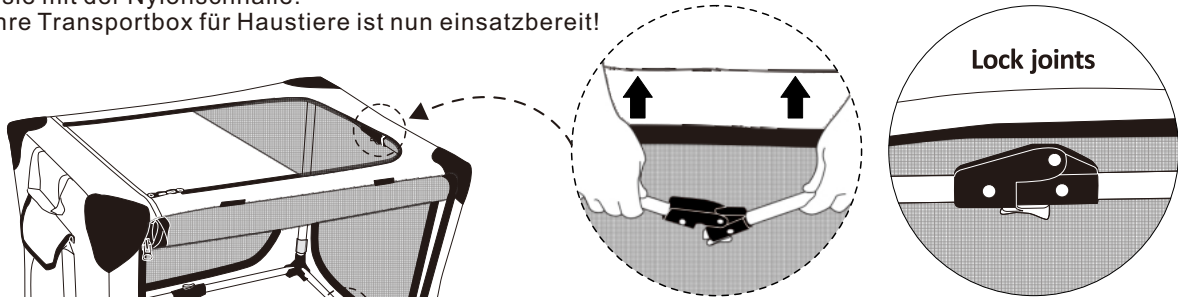

Fig 3.2.1

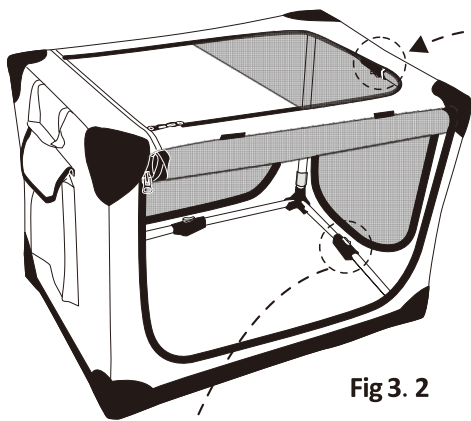

Fig 3.2

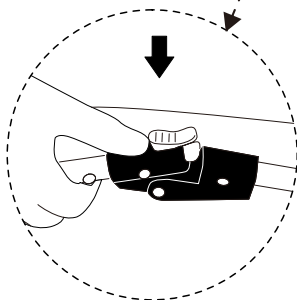

Fig 3.3

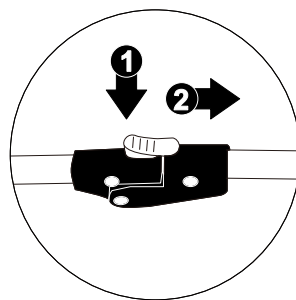

Fig 3.2.3

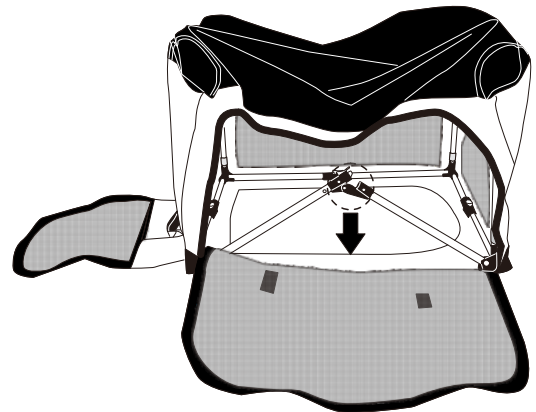

Fig 3.2.2

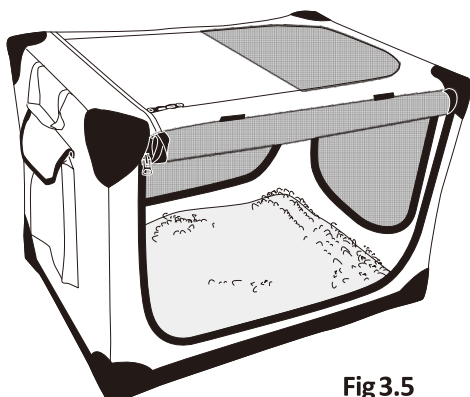

Fig 3.5

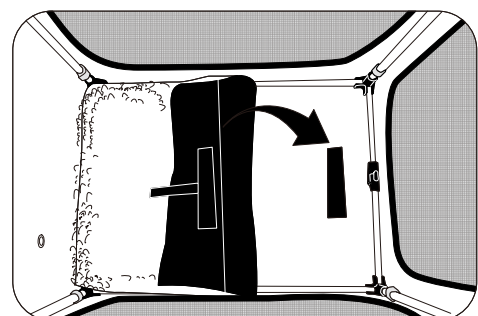

Fig 3.4

Wie faltet man die Transportbox?

1. Entfernen Sie die Unterlage aus der Transportbox. Siehe Abb. 4.1
2. Heben Sie die obere Verbindung vorsichtig an, schieben Sie den Schalter in Pfeilrichtung und drücken Sie die Verbindung nach unten. Siehe Abb. 4.2.1.

Heben Sie die übrigen Verbindungen weiter an.

3. Schieben Sie den Schalter an der unteren Verbindung in Pfeilrichtung und ziehen Sie die Verbindung nach oben. Siehe Abb. 4.2.2
4. Falten Sie die Transportbox diagonal. Siehe Abb. 4.3
5. Legen Sie die gefaltete Transportbox auf die Haustierunterlage. Wickeln Sie die Transportbox mit der Unterlage ein und befestigen Sie sie mit der Nylonschnalle. Siehe Abb. 4.4
6. Legen Sie alles in die Aufbewahrungstasche. Ihre Haustier-Transportbox ist nun ordentlich verstaut! Siehe Abb. 4.5

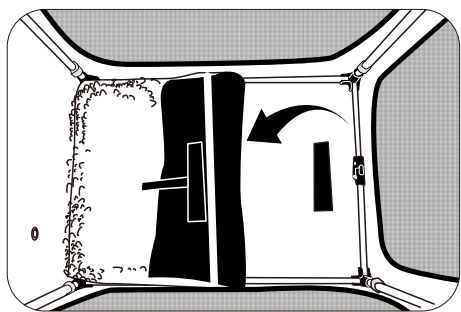

Fig 4.1

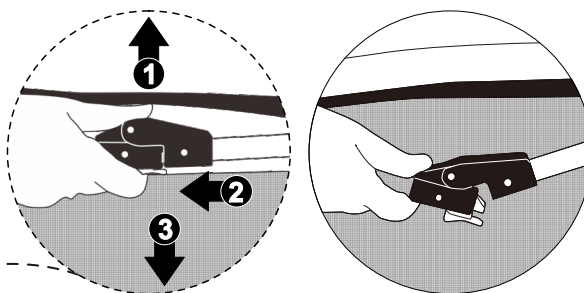

Fig 4.2.1

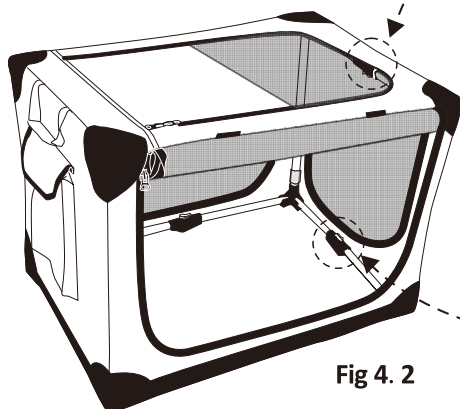

Fig 4.2

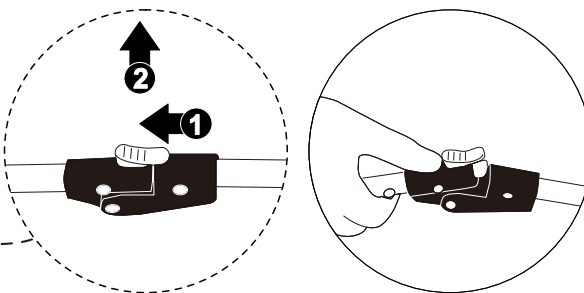

Fig 4.2.2

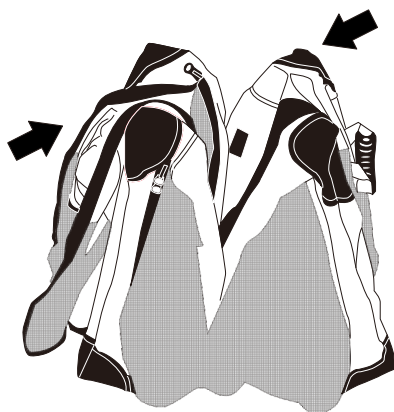

Fig 4.3

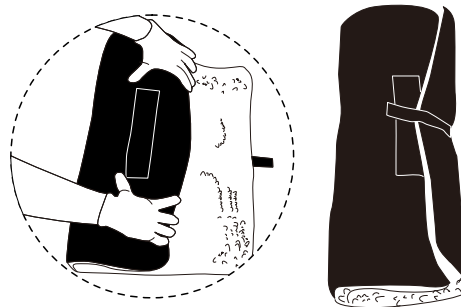

Fig 4.4

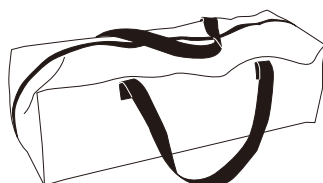

Fig 4.5



## MANUALE PER IL PIEGAMENTO DELLA GABBIA PER ANIMALI DOMESTICI

Come aprire la gabbia per animali domestici?

1. Appoggiare la gabbia per animali domestici sul pavimento e aprirla. Vedere la Fig. 3.1.
2. Tirare il giunto superiore verso l'alto fino a sentire un clic. Vedere la Fig. 3.2.1. Continuare a tirare verso l'alto i giunti rimanenti.

Nota:

- 1) Se l'ultimo giunto (troppo stretto) non può essere tirato verso l'alto, ruotare la gabbia di 180° e premere. Vedere la Fig. 3.2.2.
  - 2) Se il giunto non si apre, spingere manualmente in avanti il pulsante rosso. Vedere la Fig. 3.2.3.
  3. Premere il giunto inferiore verso il basso fino a sentire un clic. Vedere la Fig. 3.3.
- Nota: se il giunto non si apre, spingere manualmente in avanti il pulsante rosso. Vedere la Fig. 3.2.3.
4. Appoggiare il cuscino sul fondo della gabbia e fissarlo con la fibbia in nylon.
  5. La gabbia per animali domestici è ora pronta per l'uso!

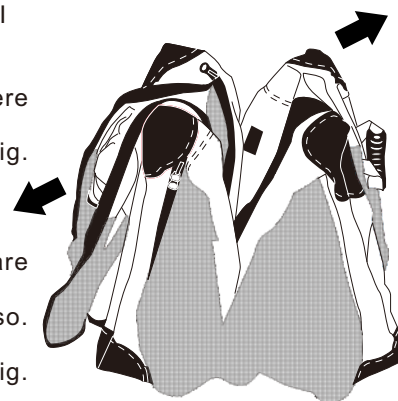

Fig 3.1

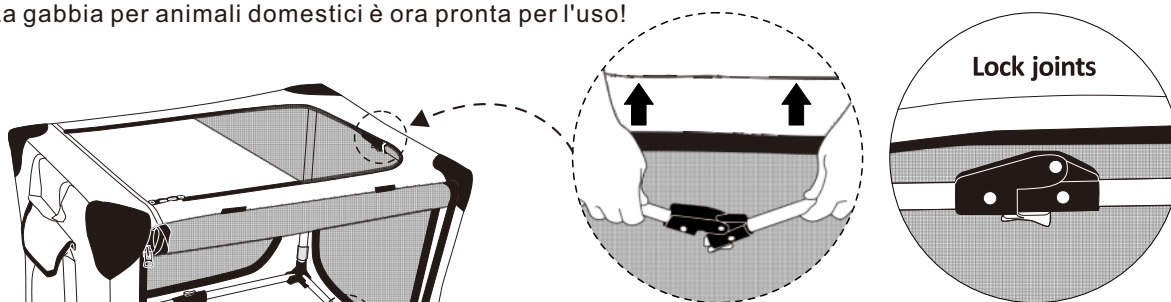

Fig 3.2.1

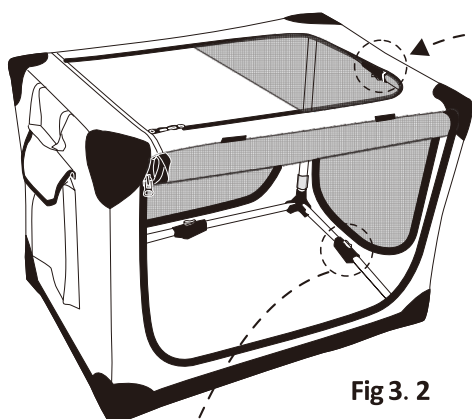

Fig 3.2

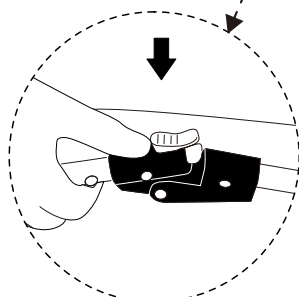

Fig 3.3

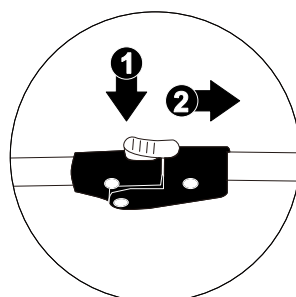

Fig 3.2.3

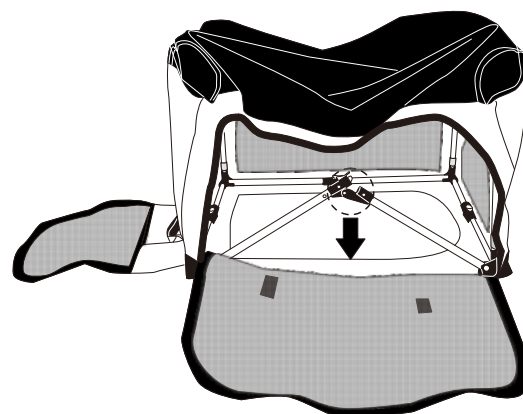

Fig 3.2.2

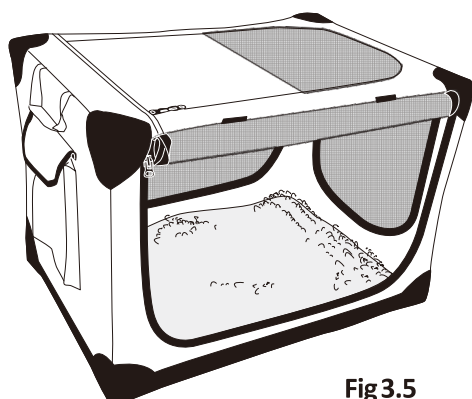

Fig 3.5

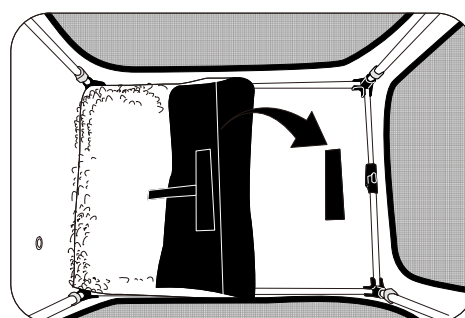

Fig 3.4

Come ripiegare la gabbia per animali domestici?

1. Rimuovere il cuscino dalla gabbia. Vedere la Fig. 4.1

2. Sollevare delicatamente il giunto superiore, far scorrere l'interruttore nella direzione della freccia e premere il giunto verso il basso. Vedere la Fig. 4.2.1.

Continuare a sollevare i giunti rimanenti.

3. Far scorrere l'interruttore sul giunto inferiore nella direzione della freccia, quindi sollevare il giunto. Vedere la Fig. 4.2.2

4. Piegare la gabbia in diagonale. Vedere la Fig. 4.3

5. Posizionare la gabbia piegata sul cuscino per animali domestici. Avvolgere la gabbia con il cuscino e fissarla utilizzando la fibbia in nylon. Vedere la Fig. 4.4

6. Riporre tutto nella borsa di stoccaggio. La gabbia per animali domestici è ora riposta in modo ordinato! Vedere la Fig. 4.5

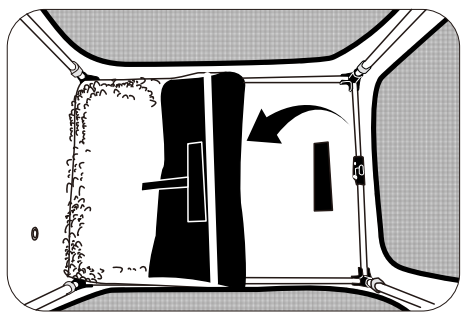

Fig 4.1

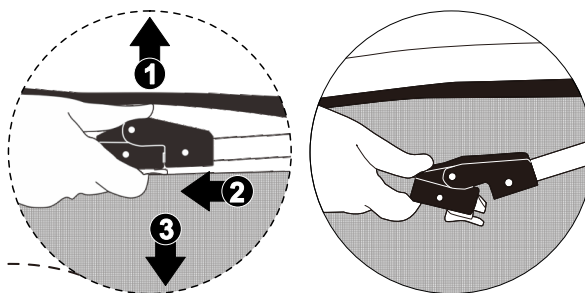

Fig 4.2.1

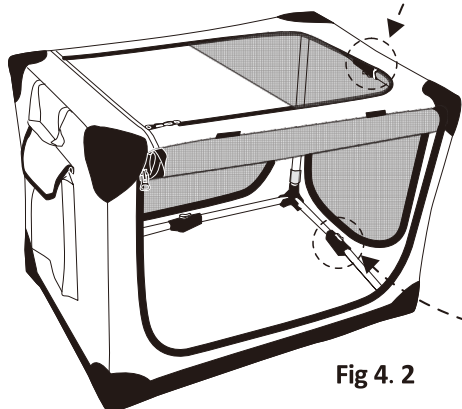

Fig 4.2

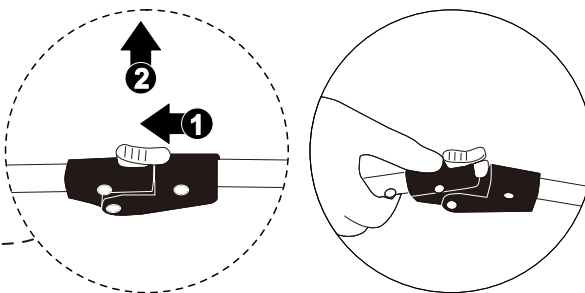

Fig 4.2.2

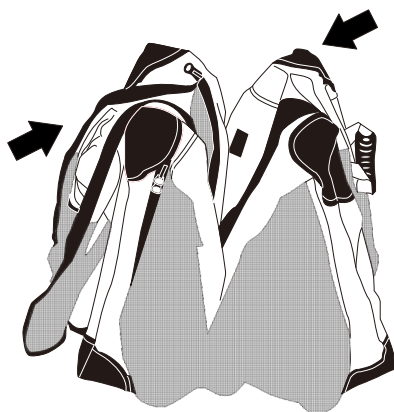

Fig 4.3

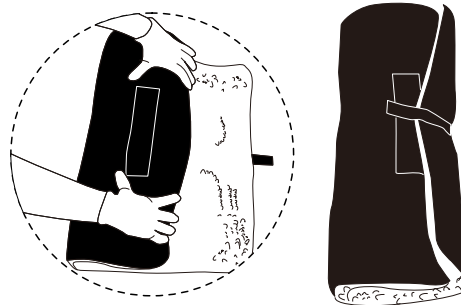

Fig 4.4

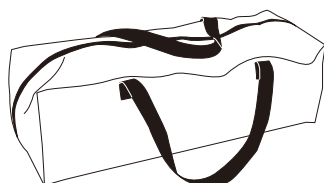

Fig 4.5



**INSTRUKCJA SKŁADANIA KLATKI DLA ZWIERZĄT**

Jak rozłożyć klatkę dla zwierząt?

1. Połóż klatkę dla zwierząt płasko na ziemi i rozłóż ją. Patrz rys. 3.1.
2. Pociągnij górne połączenie prosto do góry, aż usłyszysz kliknięcie. Patrz rys. 3.2.1. Kontynuuj podciąganie pozostałych połączeń.

Uwaga:

- 1) Jeśli ostatnie złącze (zbyt ciasne) nie da się podciągnąć, obróć klatkę o 180° i naciśnij. Patrz rys. 3.2.2.
- 2) Jeśli złącze nie otwiera się, ręcznie popchnij czerwony przycisk do przodu. Patrz rys. 3.2.3.
3. Naciśnij dolne złącze prosto w dół, aż usłyszysz kliknięcie. Patrz rys. 3.3.
- Uwaga: Jeśli połączenie nie otwiera się, należy ręcznie nacisnąć czerwony przycisk do przodu. Patrz rys. 3.2.3.
4. Połóż podkładkę płasko na dnie skrzyni i zabezpiecz ją nylonową klamrą.
5. Twoja skrzynia dla zwierząt jest teraz gotowa do użycia!

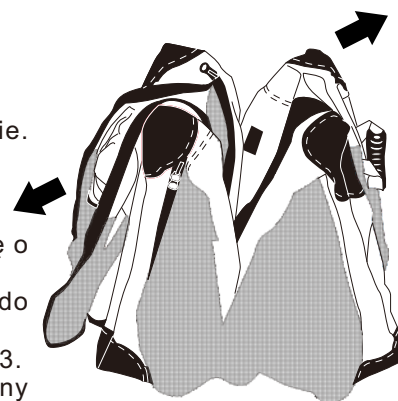

Fig 3.1

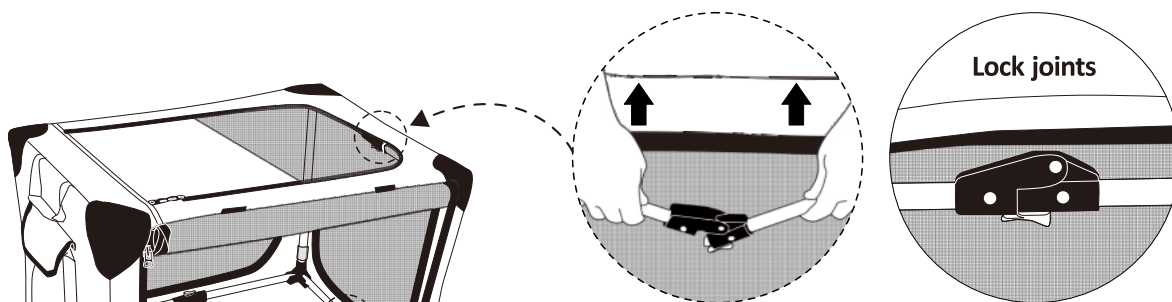

Fig 3.2.1

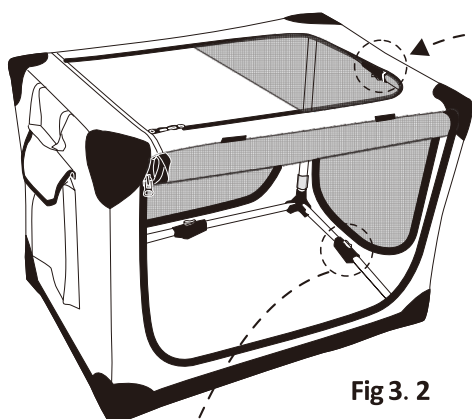

Fig 3.2

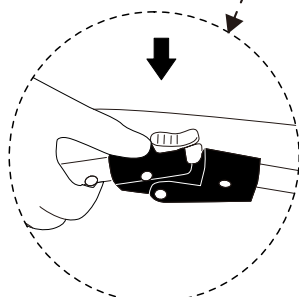

Fig 3.3

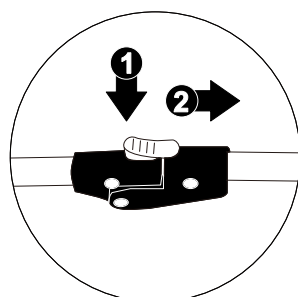

Fig 3.2.3

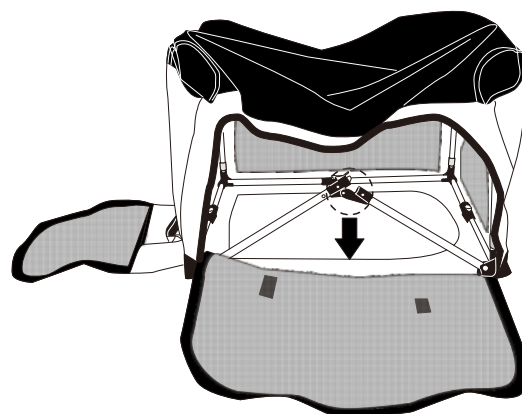

Fig 3.2.2

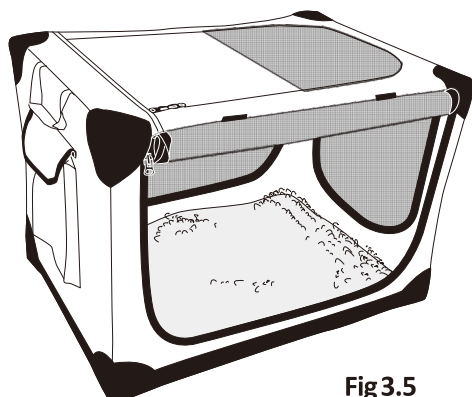

Fig 3.5

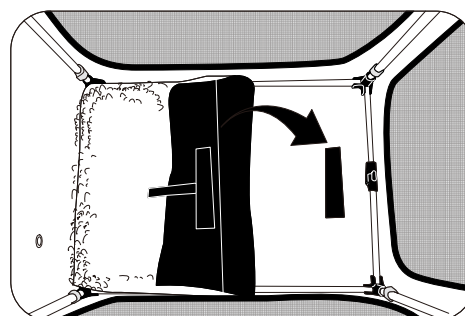

Fig 3.4

Jak złożyć klatkę dla zwierząt?

1. Wyjmij podkładkę z klatki. Patrz rys. 4.1

2. Delikatnie unieś górne połączenie, przesunij przełącznik w kierunku strzałki i naciśnij połączenie w dół. Patrz rys. 4.2.1.

Kontynuuj podnoszenie pozostałych połączeń.

3. Przesunij przełącznik na dolnym połączeniu w kierunku strzałki, a następnie podnieś połączenie. Patrz rys. 4.2.2

4. Złóż klatkę po przekątnej. Patrz rys. 4.3

5. Umieść złożoną klatkę na podkładce dla zwierząt. Owiń klatkę podkładką i zabezpiecz ją za pomocą nylonowej klamry. Patrz rys. 4.4

6. Umieść wszystko w torbie do przechowywania. Twoja klatka dla zwierząt jest teraz schludnie przechowywana! Patrz rys. 4.5

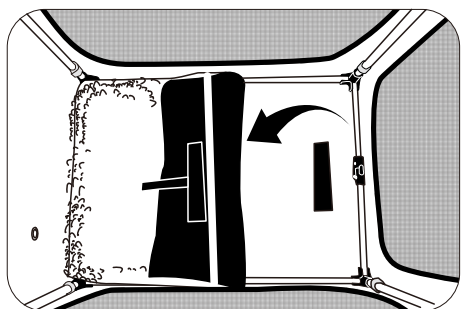

Fig 4.1

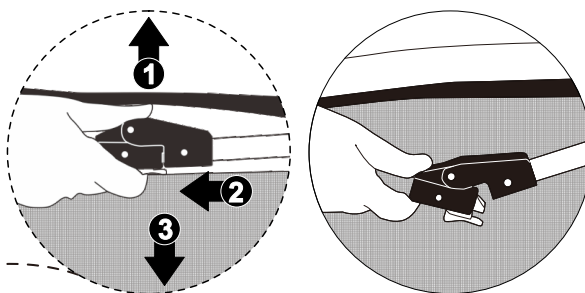

Fig 4.2.1

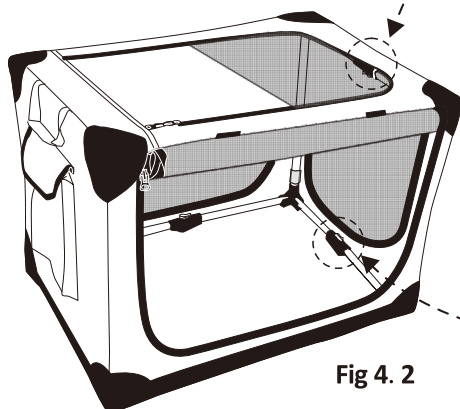

Fig 4.2

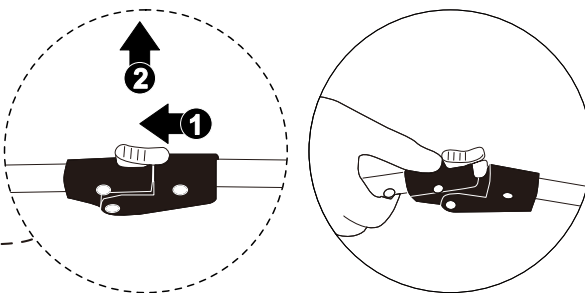

Fig 4.2.2

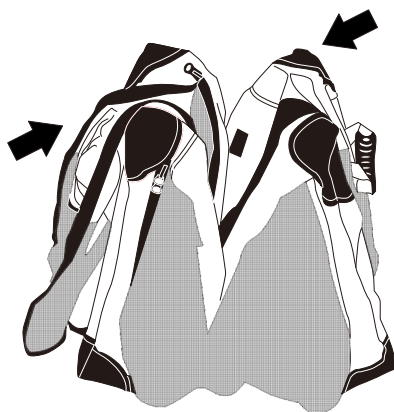

Fig 4.3

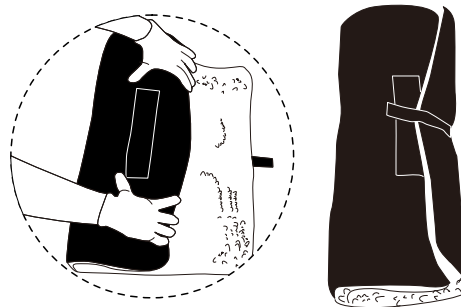

Fig 4.4

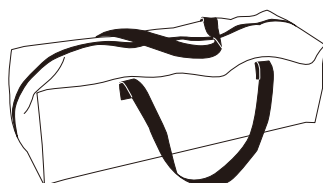

Fig 4.5



## MANUAL DE PLIERE A CUȘCII PENTRU ANIMALE DE COMPANIE

Cum se depliază cușca pentru animale de companie?

1. Așezați cușca pentru animale de companie pe sol și extindeți-o. Vezi Fig. 3.1.
2. Trageți articulația superioară în sus până când auziți un clic. Vezi Fig. 3.2.1. Continuați să trageți în sus articulațiile rămase.

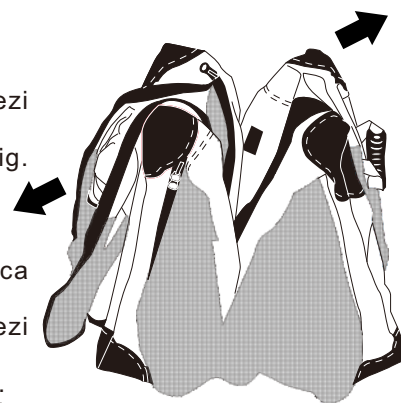

Fig 3.1

Notă:

- 1) Dacă ultima articulație (prea strânsă) nu poate fi trasă în sus, rotiți cușca cu 180° și apăsați. Vezi Fig. 3.2.2.
  - 2) Dacă articulația nu se deschide, apăsați manual butonul roșu înainte. Vezi Fig. 3.2.3.
  3. Apăsați articulația inferioară în jos până când auziți un clic. Vezi Fig. 3.3.
- Notă: Dacă îmbinarea nu se deschide, apăsați manual butonul roșu înainte. Vezi Fig. 3.2.3.
4. Așezați tamponul pe fundul cuștii și fixați-l cu catarama din nailon.
  5. Cușca pentru animale de companie este acum gata de utilizare!

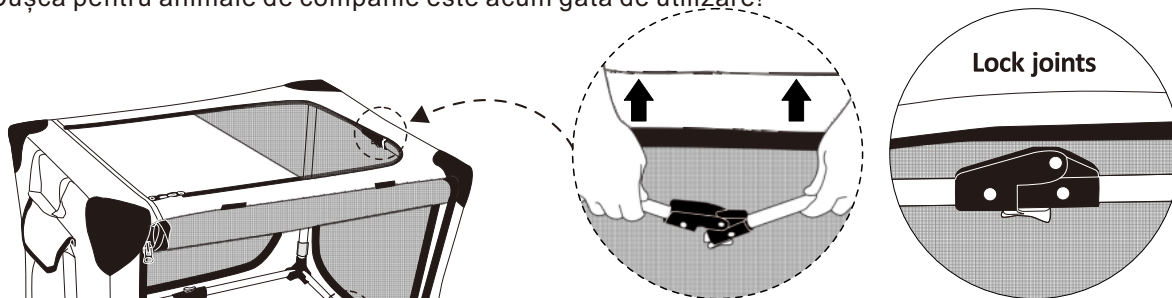

Fig 3.2.1

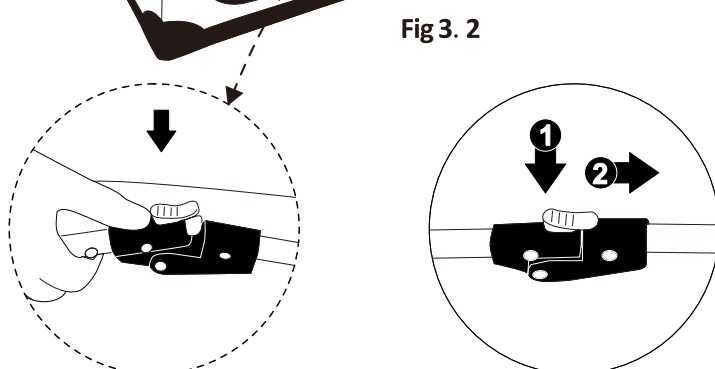

Fig 3.3

Fig 3.2.3

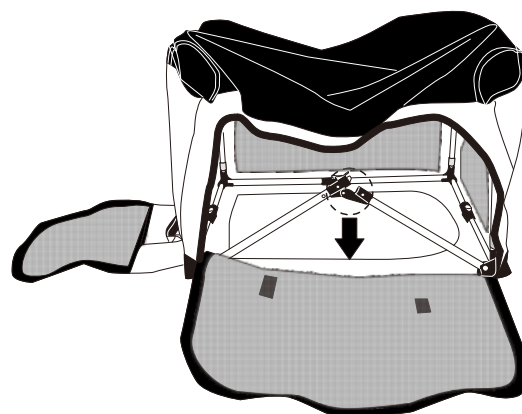

Fig 3.2.2

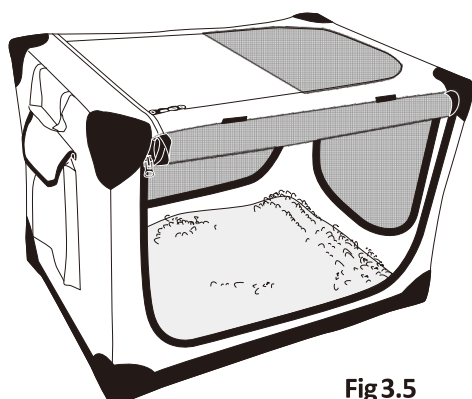

Fig 3.5

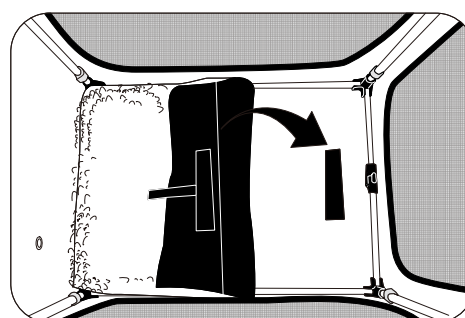

Fig 3.4

Cum se pliază cușca pentru animale de companie?

1. Scoateți perna din cușcă. Vezi Fig. 4.1

2. Ridicați ușor articulația superioară, glisați comutatorul în direcția săgeții și apăsați articulația în jos. Vezi Fig. 4.2.1.

Continuați să ridicați articulațiile rămase.

3. Glisați comutatorul de pe articulația inferioară în direcția săgeții, apoi trageți articulația în sus. Vezi Fig. 4.2.2

4. Pliati cușca în diagonală. Vezi Fig. 4.3

5. Așezați cușca pliată pe suportul pentru animale de companie. Înfășurați cușca cu suportul și fixați-o folosind catarama din nailon. Vezi Fig. 4.4

6. Puneți totul în geanta de depozitare. Cușca pentru animale de companie este acum depozitată în mod ordonat! Vezi Fig. 4.5

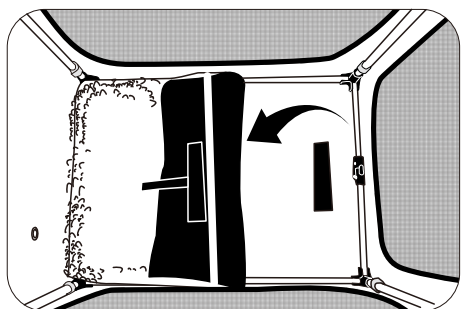

Fig 4.1

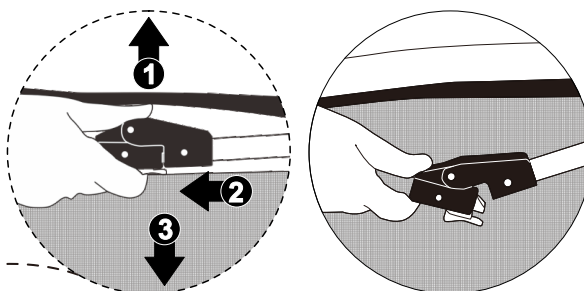

Fig 4.2.1

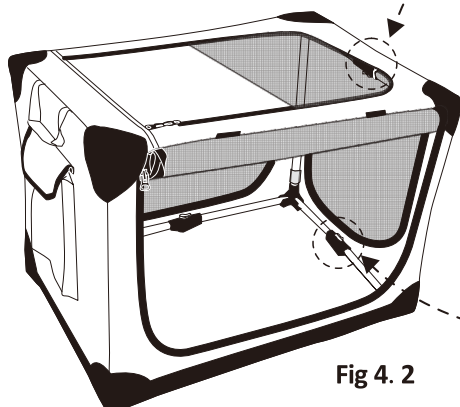

Fig 4.2

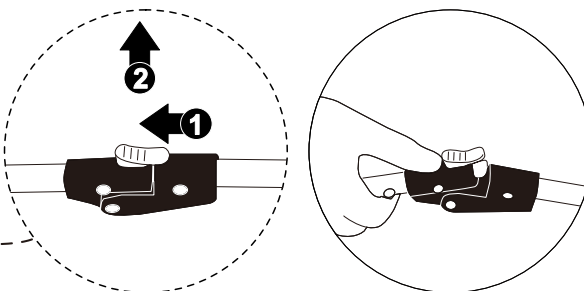

Fig 4.2.2

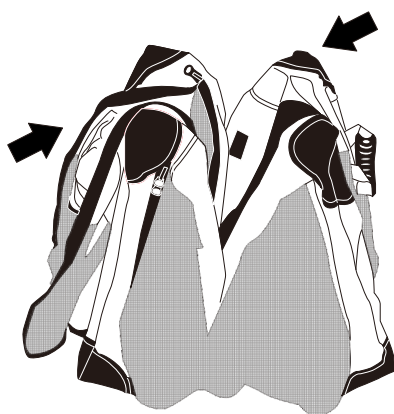

Fig 4.3

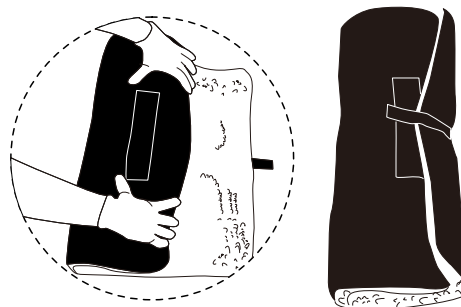

Fig 4.4

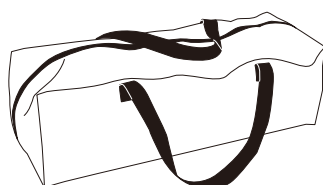

Fig 4.5

If you have any questions, please contact our customer care center, Our contact details are below:

**US**

 001-877-644-9366

 customerservice@aosom.com

Imported by Aosom LLC  
27150 SW Kinsman Rd Wilsonville, OR 97070 USA  
MADE IN CHINA

If you have any questions, please contact our customer care center, Our contact details are below:

**CA**

 416-792-6088

 customerservice@aosom.ca

Imported by Aosom Canada Inc.  
7270 Woodbine Avenue, Unit 307, Markham,  
Ontario Canada L3R 4B9  
MADE IN CHINA

Si vous avez la moindre question, veuillez contacter notre centre d'assistance à la clientèle, Nos coordonnées sont les suivantes:

 416-792-6088

 customerservice@aosom.ca

Importé par Aosom Canada Inc.  
7270 Woodbine Avenue, unité 307,  
Markham, Ontario Canada L3R 4B9  
FABRIQUÉ EN CHINE

If you have any questions, please contact our customer care center, Our contact details are below:

**UK**

 0044-800-240-4004

 enquiries@mhstar.co.uk

IMPORTER ADDRESS:  
MH STAR UK LTD  
Unit 27, Perivale Park,  
Horsenden lane South  
Perivale, UB6 7RH  
MADE IN CHINA

Si vous avez la moindre question, veuillez contacter notre centre d'assistance à la clientèle, Nos coordonnées sont les suivantes:

**FR**

 0033-1-84166106

 aosom@mhfrance.fr

Importé par/Fabricant/REP:  
MH FRANCE  
2 Rue Maurice Hartmann  
92130 Issy Les Moulineaux  
France  
FABRIQUÉ EN CHINE

Wenn Sie Fragen haben, wenden Sie sich bitte an unser Kundendienstzentrum, Unsere Kontaktdaten stehen unten:

**DE**

 0049-0(40)-87408465

 service@aosom.de

ADRESSE DES IMPORTEURE/Hersteller/REP:  
MH Handel GmbH  
Wendenstraße 309  
D-20537 Hamburg  
Germany  
IN CHINA HERGESTELLT

In caso di dubbio, si prega di contattare il nostro centro assistenza clienti, I nostri dettagli di contatto sono di seguito:

**IT**

 0039-0249471447

 clienti@aosom.it

IMPORTATO DA/Produttore/REP:  
AOSOM Italy srl  
Centro Direzionale Milanofiori  
Strada 1 Palazzo F1  
20057 Assago (MI)  
P.I.: 08567220960  
FATTO IN CINA

Si tiene alguna pregunta, comuníquese con nuestro Centro de Atención al Cliente, Nuestros datos de contacto son los siguientes:

**ES**

 0034-931294512

 atencioncliente@aosom.es

IMPORTADOR/Fabricante/REP:  
SPANISH AOSOM, S.L.  
C/ROC GROS, N°15.08550, ELS HOSTALETS DE  
BALENYÀ, SPAIN.  
B66295775  
HECHO EN CHINA

Se tiver alguma dúvida, por favor contacte o nosso Centro de Atendimento ao Cliente, Os nossos dados de contacto são os seguintes:

 0034-931294512

 info@aosom.pt.

IMPORTADOR/Fabricante/REP:  
SPANISH AOSOM, S.L.  
C.ROC GROS N.15, 08550. ELS HOSTALETS DE  
BALENYÀ  
FEITO NA CHINA



**FR**

**DONNEZ  
OU  
RECYCLEZ**



ASSOCIATION

OU



LIVRAISON

OU



DÉCHÈTERIE

Adresses sur [quefairedemesdechets.fr](http://quefairedemesdechets.fr)