

AIYAPLAY

IN250300039V01_UK

400-025V70

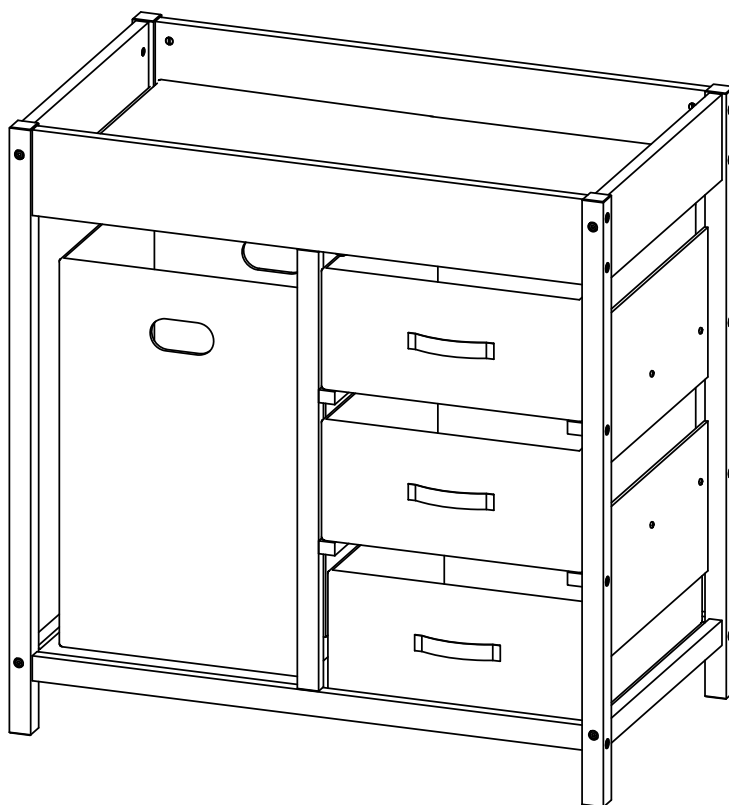

BABY CHANGING TABLE



**IMPORTANT, RETAIN FOR FUTURE REFERENCE:
READ CAREFULLY**



WARNING: Adult Assembly Required.
Read all instructions before using Changing Table.
This manual is part of the product and must be kept for future reference.

Assembly Instructions

WARNING

 Do not leave the child unattended.



 All assembly fittings shall always be correctly tightened and checked regularly.

 Be aware of the risk of open fires and other sources of strong heat, such as electric bar fires, gas fires, etc. in the near vicinity of the changing unit.

CARE AND CLEANING:

Wipe the table, pad, and safety belt clean with a damp cloth and mild soap as needed. Dry thoroughly. Spot clean hamper and baskets as needed.

Do not use product if it is damaged or broken

Do not immerse hamper and baskets in water.

 That when lock able castors/wheels are fitted, they shall be locked when the changing unit is in use.

 Weight/age of the child for which the product is intended: for type 1 changing units: 12 months, up to 11 kg.

 Not to use the changing unit when any part is broken, torn or missing.







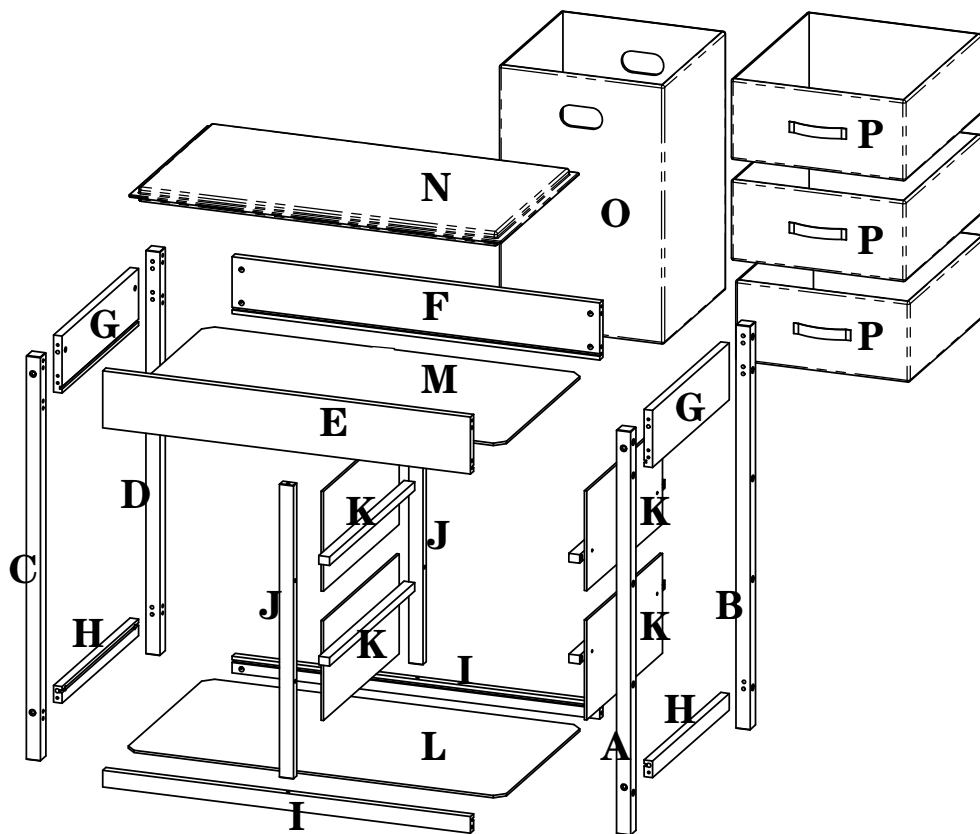
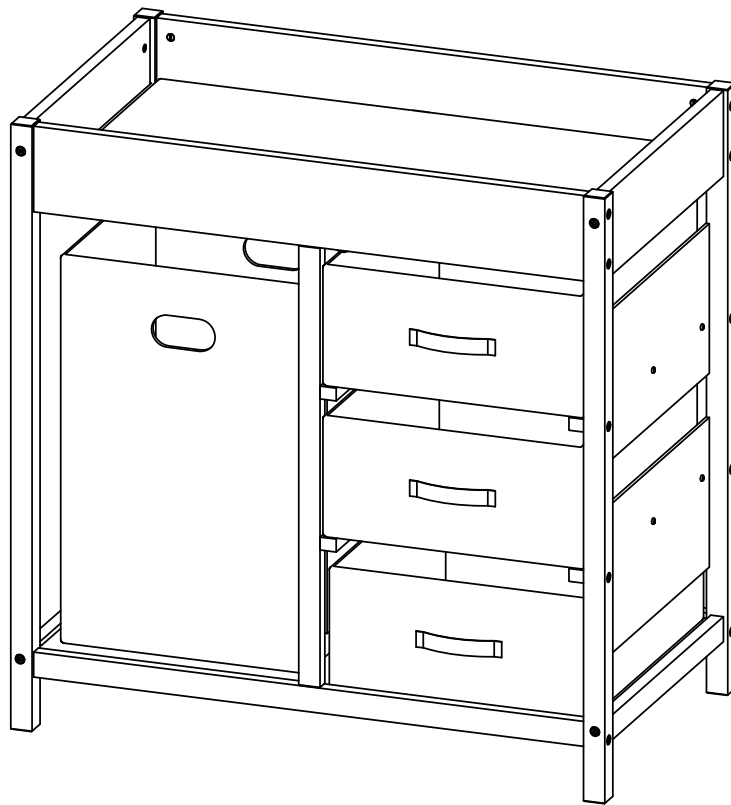

 Model Number: 400-025V70WT(PH-24001) 400-025V70GY(PH-24001)

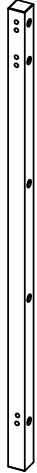
 The number and year of this European Standard: EN12221-1:2008+A12013

 Statement any additional or replacement parts shall only be obtained from the manufacturer or distributor;

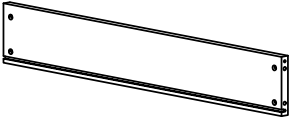
Installation Steps

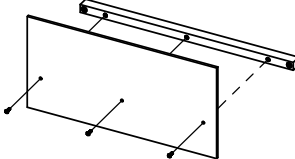
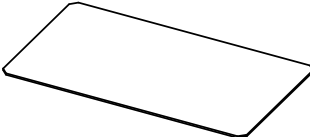
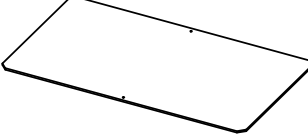
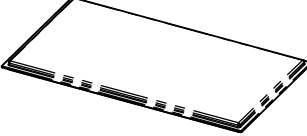
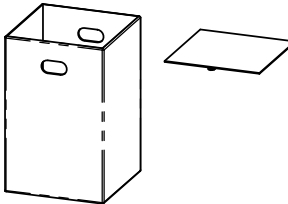
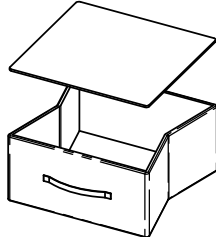
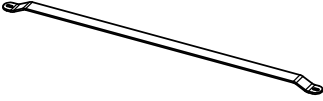
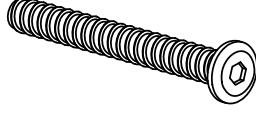
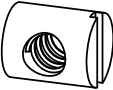
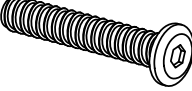
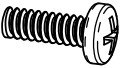

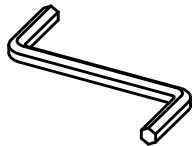
| | | | | | |
|---|---|--|--|---|--|
| <p>A</p>  <p>1PCS</p> | <p>B</p>  <p>1PCS</p> | <p>C</p>  <p>1PCS</p> | <p>D</p>  <p>1PCS</p> | <p>E</p>  <p>1PCS</p> | <p>F</p>  <p>1PCS</p> |
| <p>I</p>  <p>2PCS</p> | <p>J</p>  <p>2PCS</p> | <p>K</p>  <p>4PCS</p> | <p>L</p>  <p>1PCS</p> | | |
| <p>M</p>  <p>1PCS</p> | <p>N</p>  <p>1PCS</p> | <p>O</p>  <p>1PCS</p> | <p>P</p>  <p>3PCS</p> | | |
| <p>R</p>  <p>1PCS</p> | <p>T</p>  <p>$\phi 6*60$</p> <p>20PCS</p> | <p>U</p>  <p>$\phi 6*12$</p> <p>20PCS</p> | <p>V</p>  <p>$\phi 6*40$</p> <p>8PCS</p> | | |
| <p>W</p>  <p>$\phi 4*15$</p> <p>14PCS</p> | <p>X</p>  <p>28PCS</p> | <p>Y</p>  <p>$\phi 6*30$</p> <p>4PCS</p> |  | | |

STEP 1

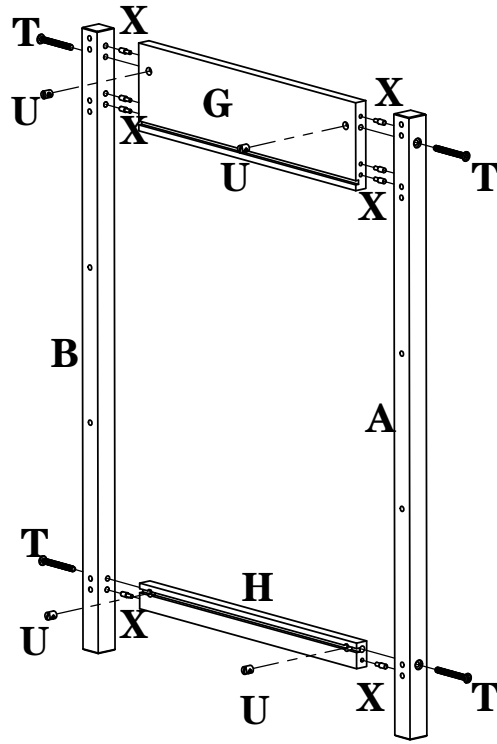

TX4



UX4



XX8

STEP 2

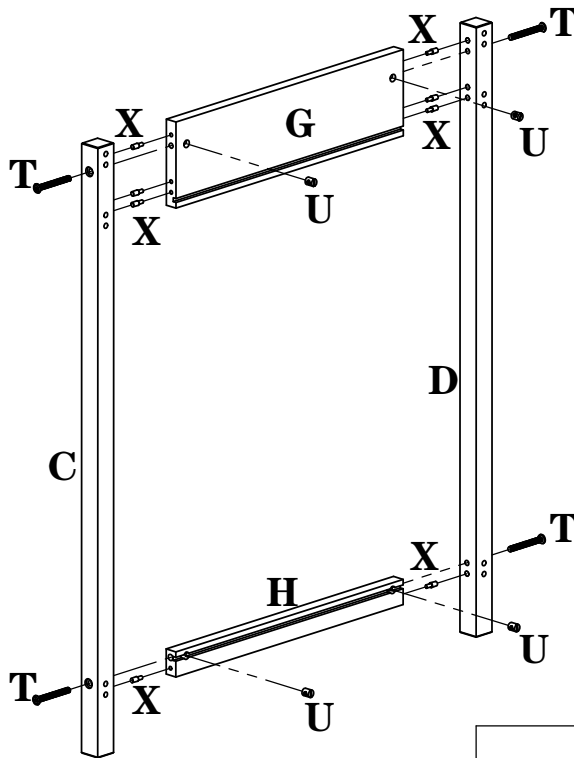

TX4



UX4



XX8

STEP 3

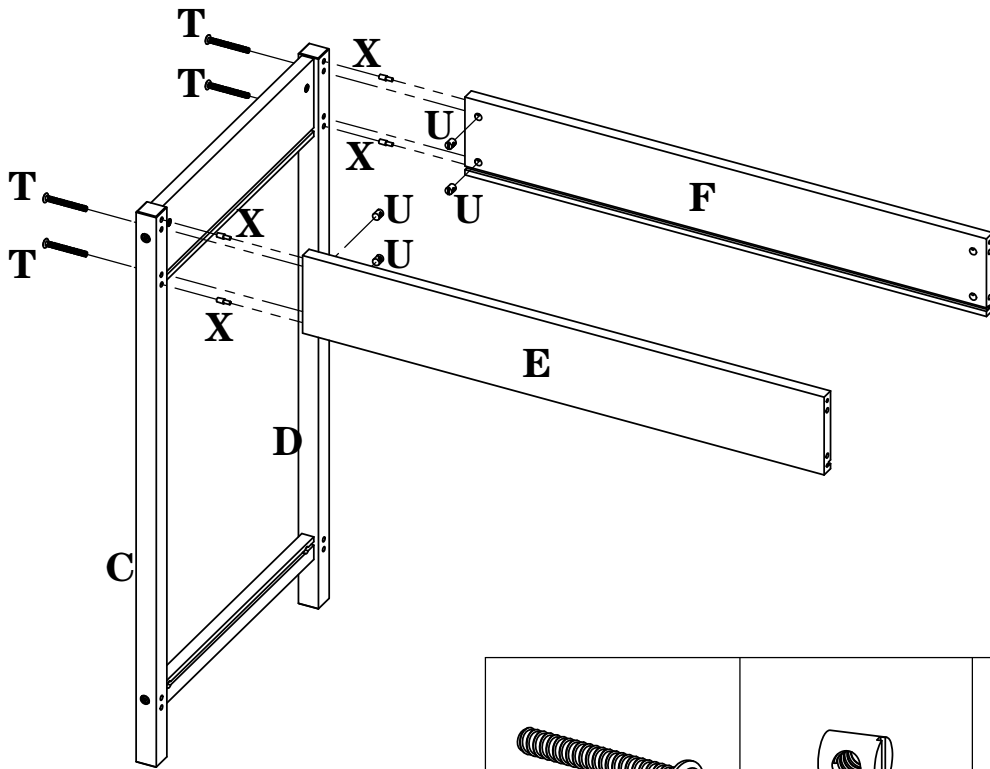

TX4



UX4



XX4

STEP 4

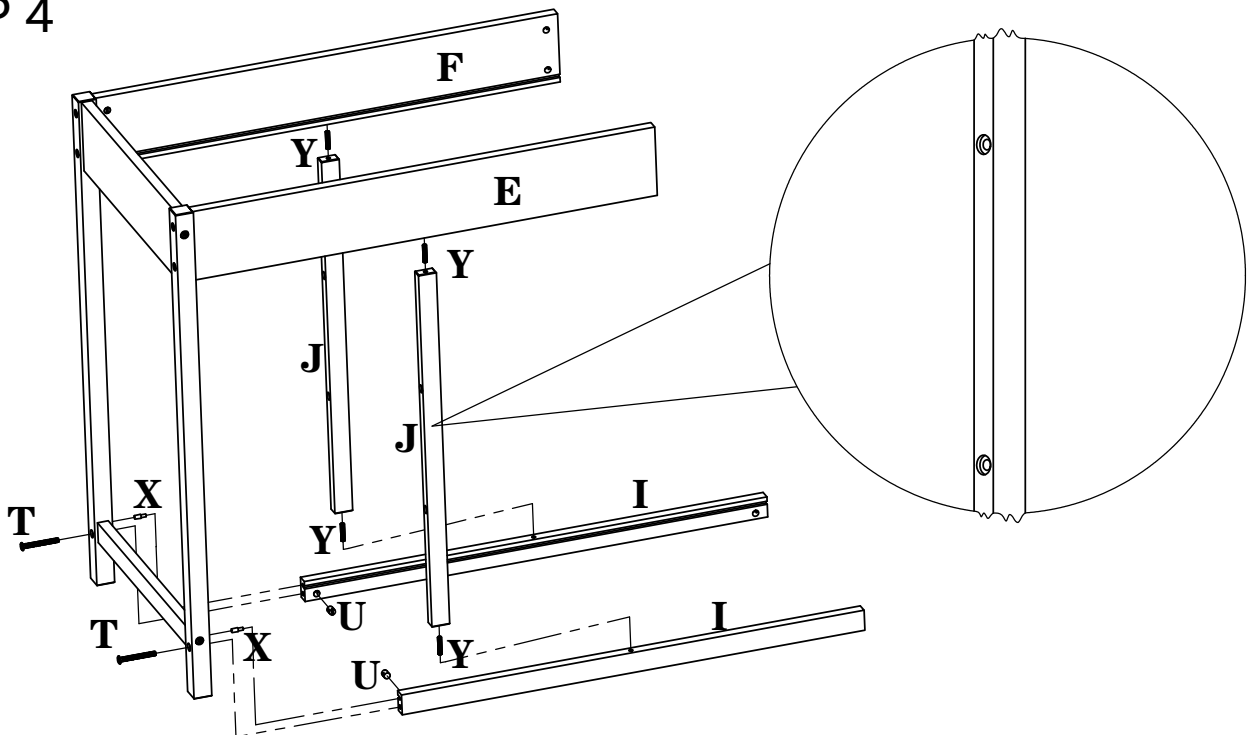

TX2



UX2



XX2



YX4

STEP 5

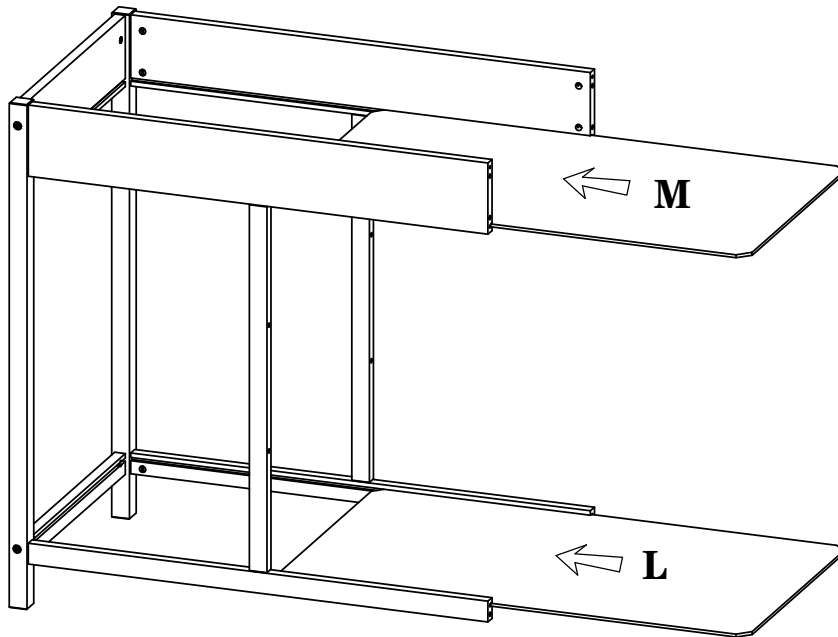

STEP 6

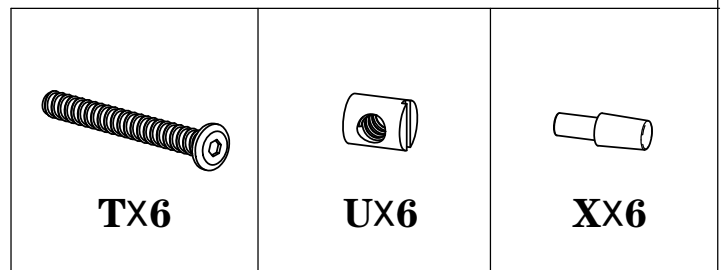
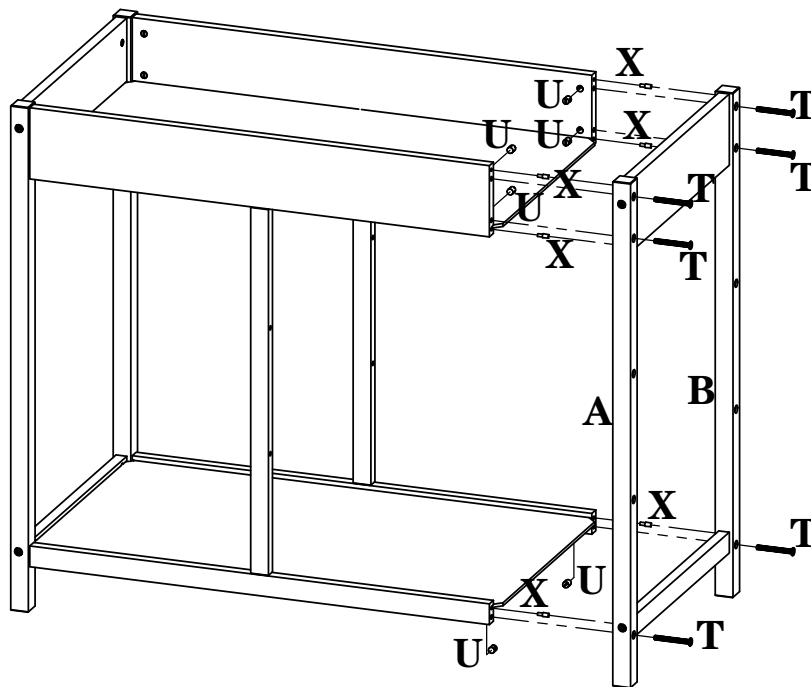

STEP 7

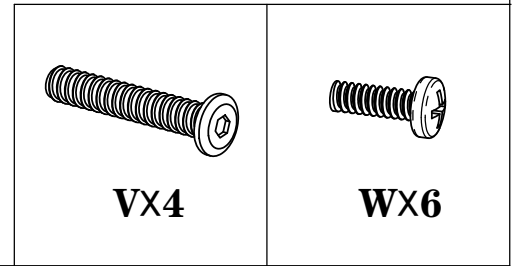
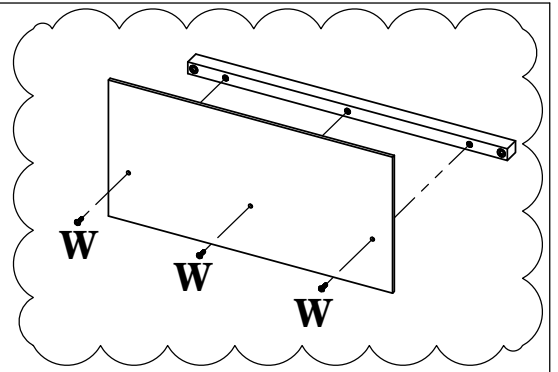
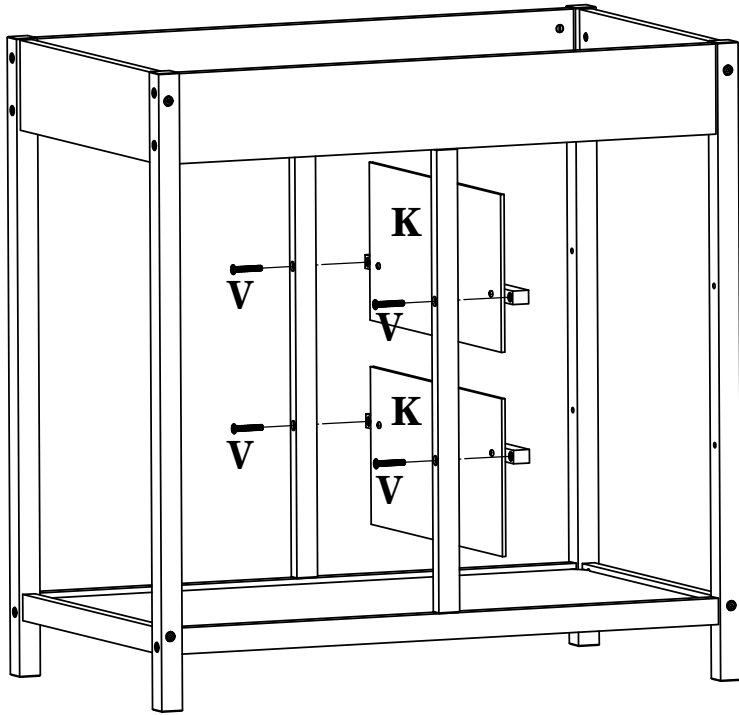

STEP 8

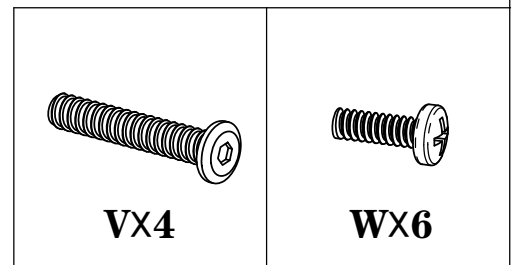
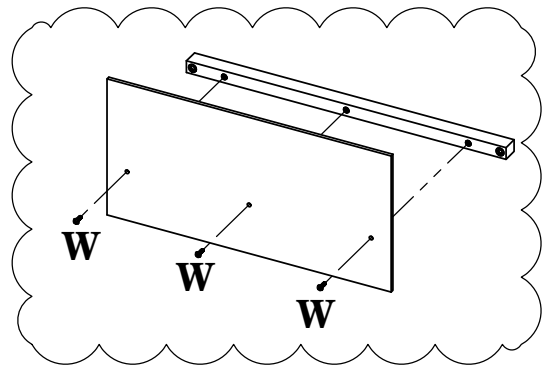
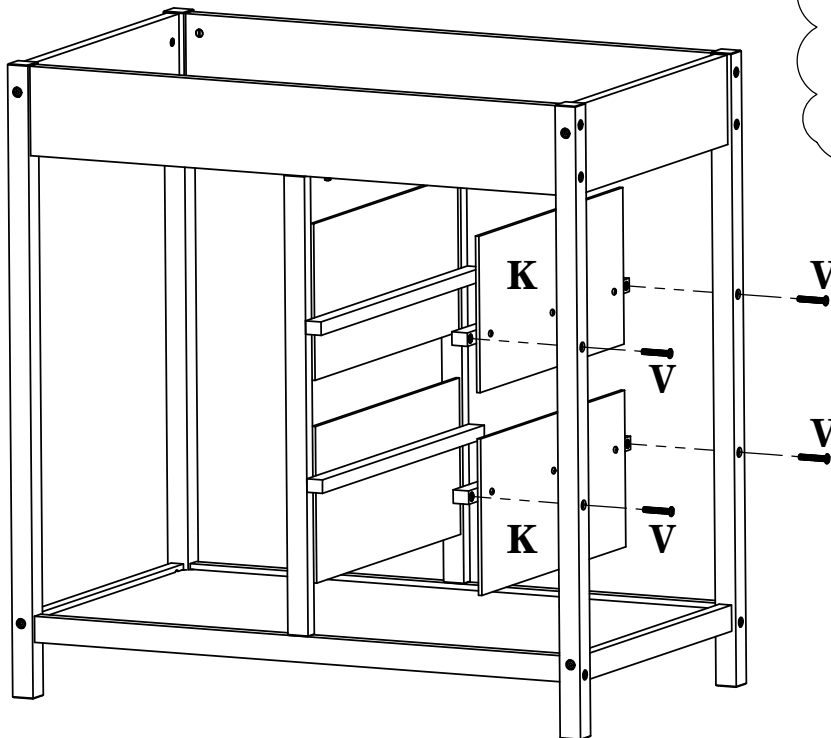

STEP 9

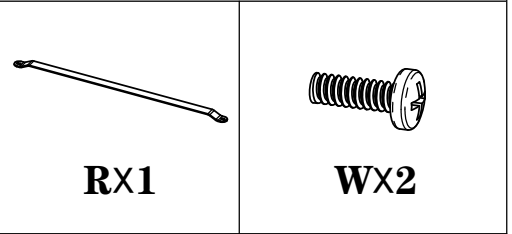
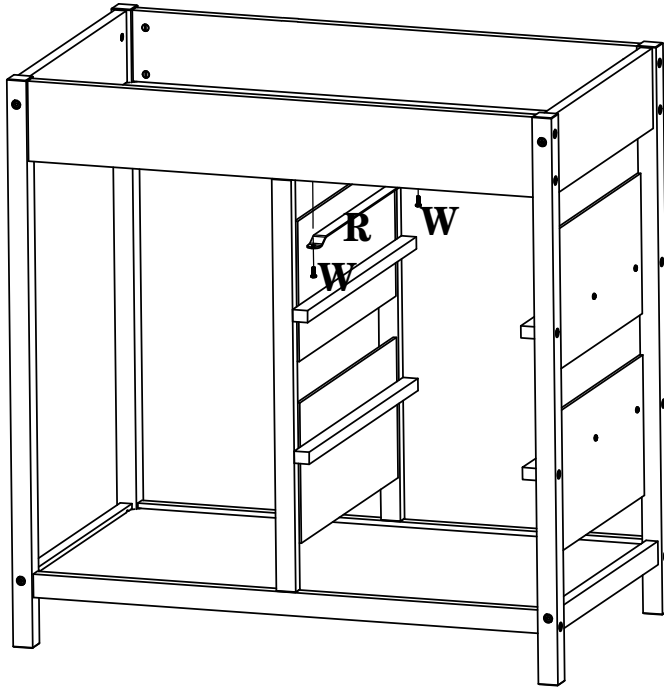

STEP 10

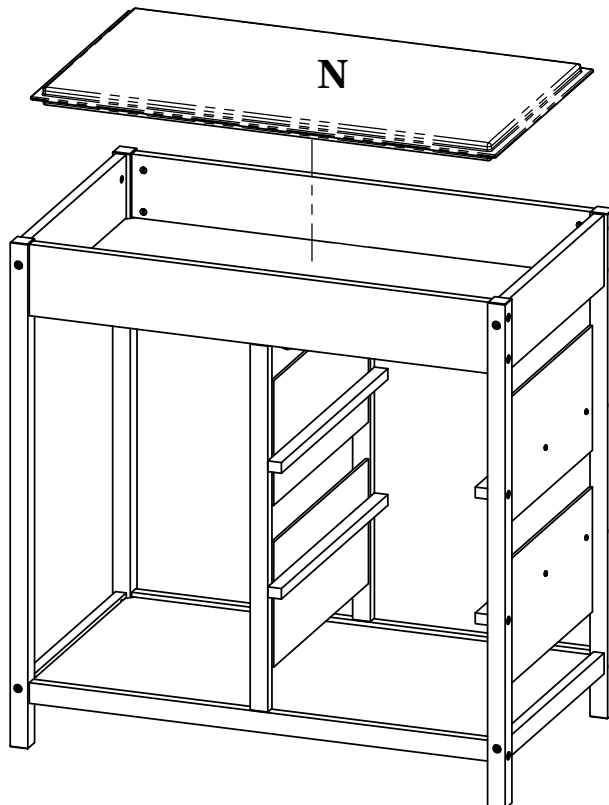

STEP 11

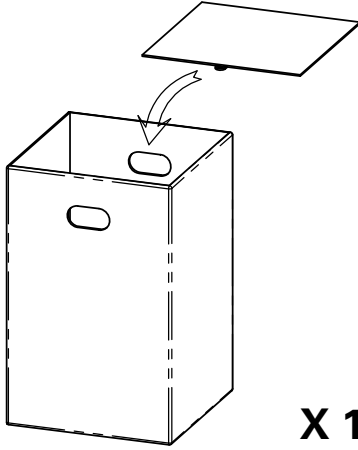
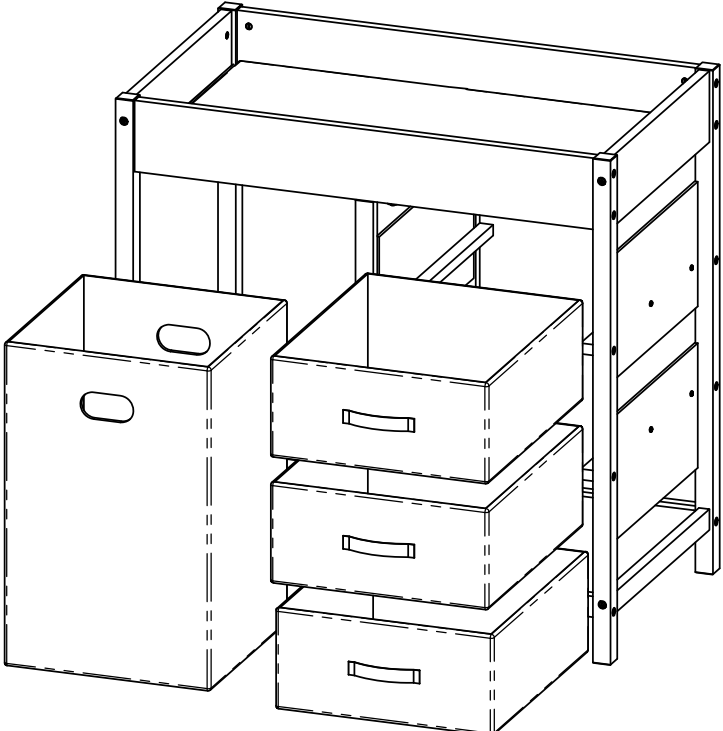

X 1

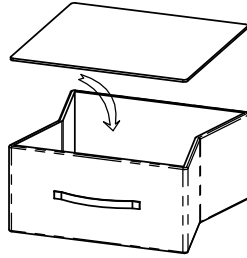

X 3

UK

If you have any questions, please contact our customer care centre.

Our contact details are below:



0044-800-240-4004



enquiries@mhstar.co.uk

IMPORTER ADDRESS:

MH STAR UK LTD

Unit 27, Perivale Park,
Horsenden lane South
Perivale, UB6 7RH
MADE IN CHINA

ES

Si tiene alguna pregunta, comuníquese con nuestro Centro de Atención al Cliente. Nuestros datos de contacto son los siguientes:



0034-931294512



atencioncliente@aosom.es

IMPORTADOR:

SPANISH AOSOM, S.L.
C/ ROC GROS, N° 15. 08550, ELS HOSTALETES DE
BALENYÀ, SPAIN.
B66295775
WWW.AOSOM.ES
ATENCIONCLIENTE@AOSOM.ES
TEL: 931294512
HECHO EN CHINA

FR

Si vous avez la moindre question, veuillez contacter notre centre d'assistance à la clientèle.

Nos coordonnées sont les suivantes:



0033-1-84166106



aosom@mhfrance.fr

Importé par:

MH France
2, rue Maurice Hartmann
92130 Issy-les-Moulineaux
France
Fabriqué en Chine

PT

Se tiver alguma dúvida, por favor contacte o nosso Centro de Atendimento ao Cliente. Os nossos dados de contacto são os seguintes:



0034-931294512



info@aosom.pt.

IMPORTADOR:

SPANISH AOSOM, S.L.
C.ROC GROS N.15, 08550. ELS HOSTALETES DE BALENYÀ
TEL: 931294512 (SEG-SEX DAS 7:30H ÀS 16:30H)
INFO@AOSOM.PT
WWW.AOSOM.PT

DE

Wenn Sie Fragen haben, wenden Sie sich bitte an unser Kundendienstzentrum.

Unsere Kontaktdaten stehen unten:



0049-0(40)-87408465



service@aosom.de

ADRESSE DES IMPORTEURE:

MH Handel GmbH
Wendenstraße 309
D-20537 Hamburg
Germany
IN CHINA HERGESTELLT

IT

In caso di dubbio, si prega di contattare il nostro centro assistenza clienti. I nostri dettagli di contatto sono di seguito:



0039-0249471447



clienti@aosom.it

IMPORTATO DA:

AOSOM Italy srl
Centro Direzionale Milanofiori
Strada 1 Palazzo F1
20057 Assago (MI)
P.I.: 08567220960
FATTO IN CINA

