

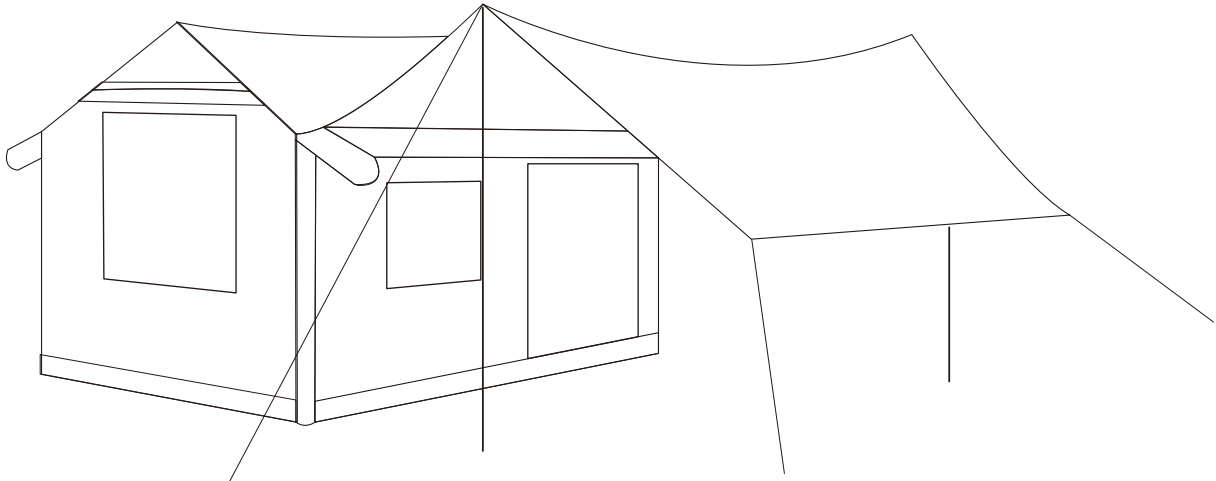

IN251100115V01\_UK\_FR\_DE\_ES\_PT\_IT\_US\_CA

**A20-581V00**



Original instructions  
Instructions d'origine  
Originalbetriebsanleitung  
Instrucciones originales  
Instruções originais  
Istruzioni originali

**EN\_IMPORTANT, RETAIN FOR FUTURE REFERENCE: READ CAREFULLY.**

**FR\_IMPORTANT : A LIRE ATTENTIVEMEN ET A CONSERVER POUR VOUS Y REFERER ULTERIEUREMENT.**

**ES\_IMPORTANTE, LEA Y GUARDE PARA FUTURAS REFERENCIAS.**

**PT\_IMPORTANTE, RETER PARA REFERÊNCIA FUTURA: LEIA ATENTAMENTE.**

**DE\_WICHTIG! SORGFÄLTIG LESEN UND FÜR SPÄTER NACHSCHLAGEN AUFBEWAHREN.**

**IT\_IMPORTANTE! CONSERVARE IL PRESENTE MANUALE PER FUTURO RIFERIMENTO E LEGGERLO ATTENTAMENTE.**



**WARNING: KEEP ALL FLAME AND HEAT SOURCES AWAY FROM THIS TENT.**

**This tent is not fireproof. The fabric will burn if left in continuous contact with a flame source.**

### Precautions

- Do NOT use candles, matches or other open flames in or near a tent.
- Fuel-powered lanterns and appliances are NOT recommended for use in or near a tent. If fuel-powered lanterns or appliances such as wood stoves or electric heaters are used, **exercise extreme caution**. Keep them away from the tent walls. Do NOT leave them unattended. Turn them off before going to sleep. Make sure the tent is well ventilated at all times to avoid suffocation.
- Build campfires downwind and several metres away from a tent. Extinguish campfires before leaving a campsite or going to sleep.
- Do NOT fuel lamps, heaters or stoves in a tent.
- Do NOT smoke in a tent.
- Do NOT store flammable liquids in a tent.
- Keep exits clear.
- Do NOT apply any foreign substance to a tent. It may diminish the flame resistant properties of tent material(s).



**MISE EN GARDE : TENIR CETTE TENTE LOIN DE TOUTE FLAMME ET DE TOUTE SOURCE DE CHALEUR.**

**Cette tente n'est pas ininflammable. Le tissu brûlera s'il est laissé en contact continu avec une source de flamme.**

### Précautions

- NE PAS utiliser de bougies, d'allumettes ou d'autres flammes nues à l'intérieur ou à proximité d'une tente.
- Les lanternes et les appareils utilisant un combustible NE sont PAS recommandés pour une utilisation à l'intérieur ou à proximité d'une tente. Si vous utilisez des lanternes ou des appareils à combustible, tels que des poêles à bois ou des radiateurs électriques, **faites preuve d'une extrême prudence**. Gardez-les loin des parois de la tente. NE les laissez PAS sans surveillance. Éteignez-les avant d'aller vous coucher. Assurez-vous que la tente est toujours bien ventilée pour éviter l'asphyxie.
- Construire les feux de camp sous le vent et à plusieurs mètres d'une tente. Éteindre les feux de camp avant de quitter un emplacement de camping ou d'aller se coucher.
- NE PAS faire le plein de lampes, d'appareils de chauffage ou de cuisinières dans une tente.
- NE PAS fumer dans une tente.
- NE PAS entreposer de liquides inflammables dans une tente.
- Garder les sorties dégagées.
- NE PAS appliquer de substances étrangères sur une tente. Cela peut diminuer les propriétés ignifuges des matériaux de la tente.



**WARNUNG: HALTEN SIE ALLE FLAMMEN UND WÄRMEQUELLEN VON DIESEM ZELT FERN.**

**Dieses Zelt ist nicht feuerfest. Der Stoff wird brennen, wenn er in ständigem Kontakt mit einer Flamme bleibt.**

### Vorsichtsmaßnahmen

- Verwenden Sie KEINE Kerzen, Streichhölzer oder andere offene Flammen in oder in der Nähe eines Zeltes.
- Kraftstoffbetriebene Laternen und Geräte werden NICHT für die Verwendung in oder in der Nähe eines Zeltes empfohlen. Wenn kraftstoffbetriebene Laternen oder Geräte wie Holzöfen oder elektrische Heizungen verwendet werden, **ist äußerste Vorsicht geboten**. Halten Sie sie von den Zeltwänden fern. Lassen Sie sie NICHT unbeaufsichtigt. Schalten Sie sie aus, bevor Sie schlafen gehen. Stellen Sie sicher, dass das Zelt jederzeit gut belüftet ist, um Erstickung zu vermeiden.
- Lagerfeuer im Lee und mehrere Meter von einem Zelt entfernt aufbauen. Lagerfeuer vor dem Verlassen eines Campingplatzes oder vor dem Schlafengehen löschen.
- Füllen Sie keine Lampen, Heizungen oder Öfen in einem Zelt mit Brennstoff.
- Rauchen Sie NICHT in einem Zelt.
- Lagern Sie brennbare Flüssigkeiten nicht in einem Zelt.
- Halten Sie die Ausgänge frei.
- Wenden Sie keine fremden Substanzen auf einem Zelt an. Dies kann die flammhemmenden Eigenschaften des Zeltmaterials beeinträchtigen.



**ADVERTENCIA: MANTENGA TODAS LAS FUENTES DE LLAMA Y CALOR LEJOS DE ESTA TIENDA.**

**Esta tienda no es a prueba de fuego. La tela se quemará si se deja en contacto continuo con una fuente de llama.**

### Precauciones

- No use velas, fósforos ni otras llamas abiertas dentro o cerca de una tienda.
- No se recomiendan las linternas y aparatos a combustible para su uso dentro o cerca de una tienda de campaña. Si se utilizan linternas o aparatos a combustible, como estufas de leña o calefactores eléctricos, **ejerza extrema precaución**. Manténgalos alejados de las paredes de la tienda. NO los deje desatendidos. Apáguelos antes de irse a dormir. Asegúrese de que la tienda esté bien ventilada en todo momento para evitar la asfixia.
- Haga fogatas a favor del viento y a varios metros de distancia de una tienda. Apague las fogatas antes de abandonar un campamento o de irse a dormir.
- No abastezca de combustible lámparas, calefactores o estufas en una tienda.
- No fume en una tienda.
- No almacene líquidos inflamables en una tienda.
- Mantenga las salidas despejadas.
- No aplique ninguna sustancia extranjera a una tienda. Puede disminuir las propiedades de resistencia a la llama del material de la tienda.



## ADVERTÊNCIA: MANTENHA TODAS AS FONTES DE CHAMA E CALOR LONGE DESTA TENDA.

Esta tenda não é à prova de fogo. O tecido queimará se mantido em contato contínuo com uma fonte de chama.

### Precauções

- Não use velas, fósforos ou outras chamas abertas dentro ou perto de uma tenda.
- Lanternas e aparelhos a combustível NÃO são recomendados para uso dentro ou perto de uma tenda. Se lanternas ou aparelhos a combustível, como fogões a lenha ou aquecedores elétricos, forem usados, **tenha extrema cautela**. Mantenha-os afastados das paredes da tenda. NÃO os deixe sem supervisão. Desligue-os antes de ir dormir. Certifique-se de que a tenda esteja bem ventilada em todos os momentos para evitar sufocamento.
- Faça fogueiras a favor do vento e a vários metros de distância de uma tenda. Apague as fogueiras antes de deixar o acampamento ou ir dormir.
- Não abasteça lâmpadas, aquecedores ou fogões dentro de uma tenda.
- Não fume em uma tenda.
- Não armazene líquidos inflamáveis em uma tenda.
- Mantenha as saídas desobstruídas.
- Não aplique nenhuma substância estrangeira a uma tenda. Isso pode diminuir as propriedades de resistência ao fogo do(s) material(is) da tenda.



## AVVERTENZA: TENERE TUTTE LE FONTI DI FIAMMA E CALORE LONTANO DA QUESTA TENDA.

Questa tenda non è ignifuga. Il tessuto brucerà se lasciato a contatto continuo con una fonte di fiamma.

### Precauzioni

- Non utilizzare candele, fiammiferi o altre fiamme libere dentro o vicino a una tenda.
- Le lanterne e gli apparecchi a combustibile NON sono raccomandati per l'uso dentro o vicino a una tenda. Se si utilizzano lanterne o apparecchi a combustibile come stufe a legna o riscaldatori elettrici, **esercitare la massima cautela**. Tienili lontani dalle pareti della tenda. NON lasciarli incustoditi. Spegnili prima di andare a dormire. Assicurati che la tenda sia ben ventilata in ogni momento per evitare soffocamenti.
- Accendere fuochi da campo sottovento e a diversi metri di distanza da una tenda. Spegnere i fuochi da campo prima di lasciare un campeggio o andare a dormire.
- Non alimentare lampade, riscaldatori o stufe in una tenda.
- Non fumare in una tenda.
- Non conservare liquidi infiammabili in una tenda.
- Tenere le uscite libere.
- Non applicare alcuna sostanza estranea a una tenda. Potrebbe ridurre le proprietà di resistenza al fuoco dei materiali della tenda.

## SIZE

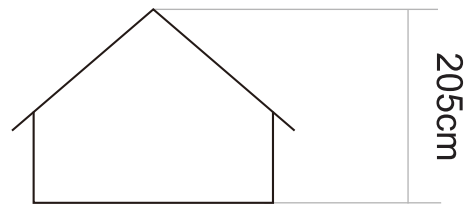
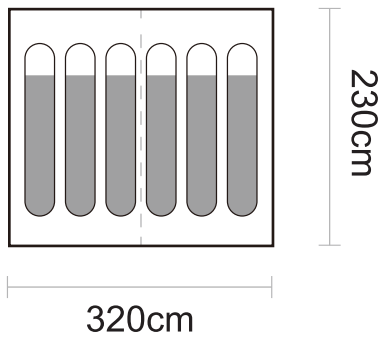

## ACCESSORY

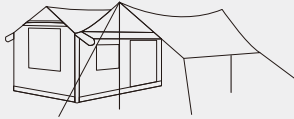

Tent\*1



Storage bag\*1



Tent peg\*24



Wind rope\*8



Tent pole\*2

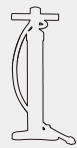

Pressure limiting pump\*1

## ATTENTION

- Please check the manual carefully and make sure you have received all the parts.
- If there is any missing, please let us know the letter of the parts you need.
- If there is any damage, please send clear photos to us, and we will check and offer you the best solution soon.

## INSTALLATION STEPS

01

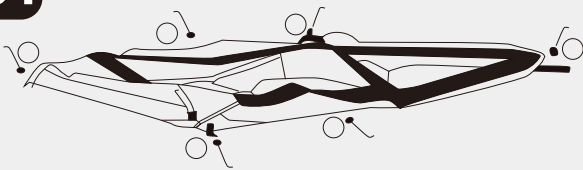

1. Unfold the tent and fix the 6 positions on the ground with steel nails.

02

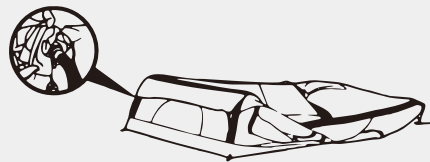

2. Connect the pump to the nozzle.

03

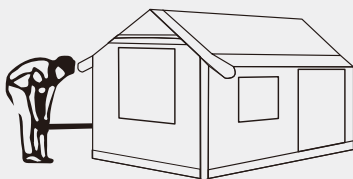

3. Pump for 3-5 minutes until the tent is fully open and the column is firm.

04

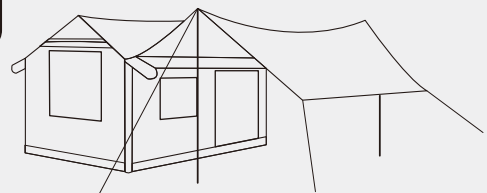

4. Put nails well, pull away the wind rope and secure it.

## TAILLE

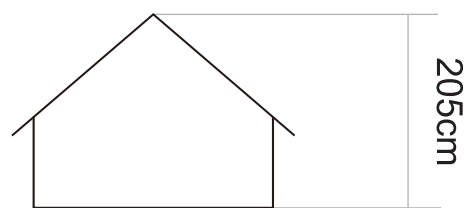
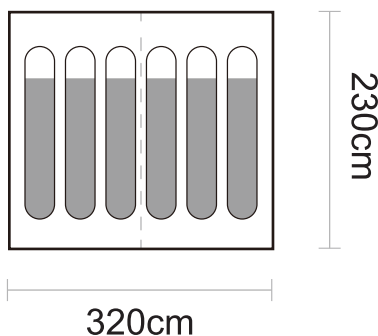

## ACCESSOIRE

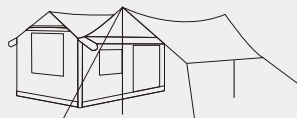

Tente\*1

Sac de rangement\*  
1

Tente piquet\*24

Corde de randonnée\*  
8

Poteau de tente\*2

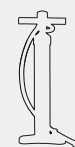

Pompe limiteuse de pression\*1

## ATTENTION

- Veuillez lire attentivement le manuel et vous assurer que vous avez reçu toutes les pièces.
- S'il en manque, veuillez nous indiquer la lettre des pièces dont vous avez besoin.
- En cas de dommage, veuillez nous envoyer des photos claires ; nous vérifierons et vous proposerons bientôt la meilleure solution.

## ÉTAPES D'INSTALLATION

01

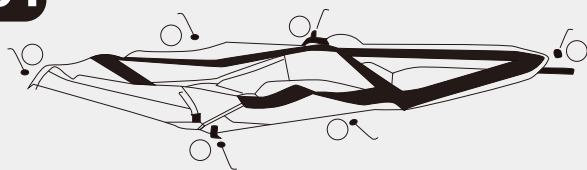

1. Dépliez la tente et fixez les 6 positions au sol avec des clous en acier.

02

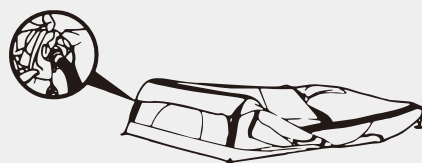

2. Branchez la pompe à l'embout.

03

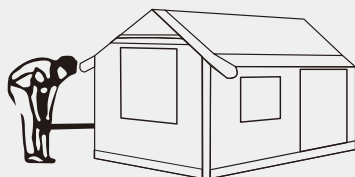

3. Pompez pendant 3 à 5 minutes jusqu'à ce que la tente soit complètement déployée et que la colonne soit ferme.

04

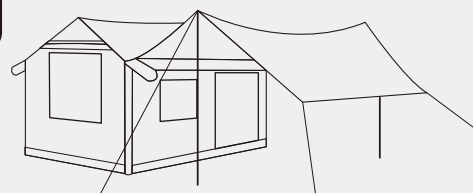

4. Clouez bien, détachez la corde de vent et sécurisez-la.

## GRÖSSE

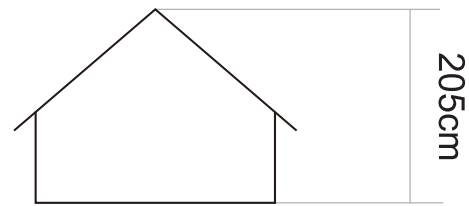
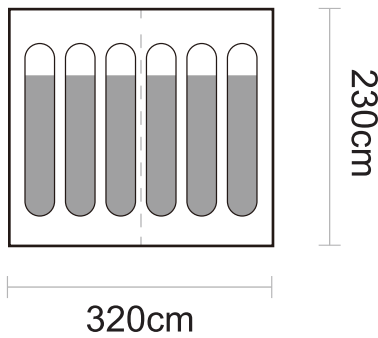

## ZUBEHÖR



Zelt\*1



Aufbewahrungsbügel\*1



Zeltpflock\*24



Abspannleine\*8



Zeltstange\*2



Druckbegrenzungspumpe\*1

## ACHTUNG

- Bitte lesen Sie die Bedienungsanleitung sorgfältig durch und stellen Sie sicher, dass Sie alle Teile erhalten haben.
- Falls etwas fehlt, teilen Sie uns bitte den Buchstaben der benötigten Teile mit.
- Falls etwas beschädigt ist, senden Sie uns bitte klare Fotos, damit wir dies prüfen und Ihnen schnellstmöglich die beste Lösung anbieten können.

## INSTALLATIONSSCHRITTE

01

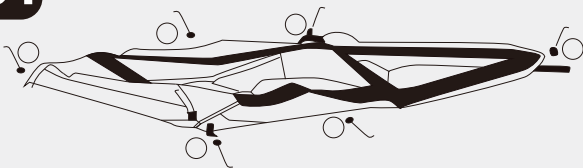

1. Falten Sie das Zelt auseinander und befestigen Sie die 6 Positionen am Boden mit Stahlnägeln.

02

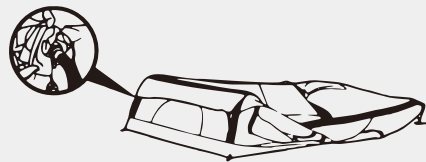

2. Verbinden Sie die Pumpe mit der Düse.

03

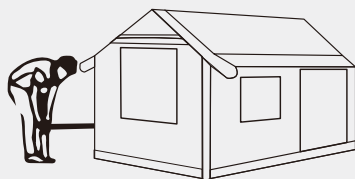

3. Pumpen Sie 3–5 Minuten, bis das Zelt vollständig geöffnet und die Säule fest ist.

04

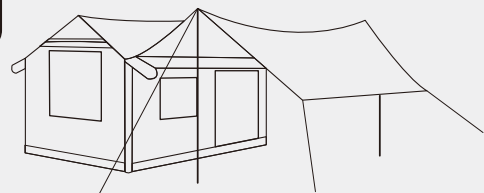

4. Nagel gut anbringen, die Windschnur wegziehen und sichern.

## TALLA

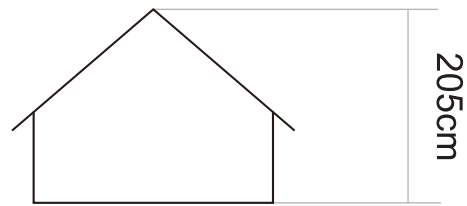
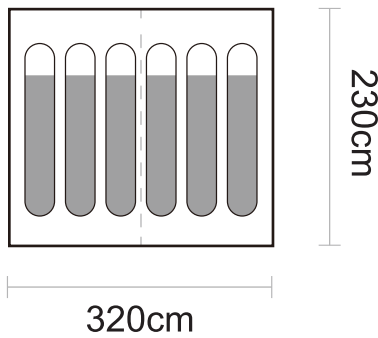

## ACCESORIO

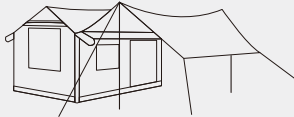

Tienda\*1

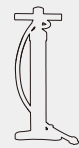
Bolsa de  
almacenami  
ento\*1Estaca  
para  
tienda\*24Cuerda de  
viento\*8Asta de  
tienda\*2Bomba  
limitadora de  
presión\*1

## ATENCIÓN

- Por favor, revise el manual detenidamente y asegúrese de haber recibido todas las piezas.
- Si falta alguna, indíquenos la letra de las piezas que necesita.
- Si hay algún daño, envíenos fotos claras y las revisaremos para ofrecerle la mejor solución pronto.

## PASOS DE INSTALACIÓN

01

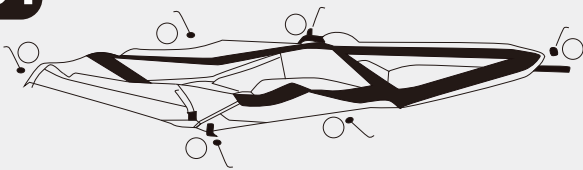

1. Despliegue la tienda y fije las 6 posiciones en el suelo con clavos de acero.

02

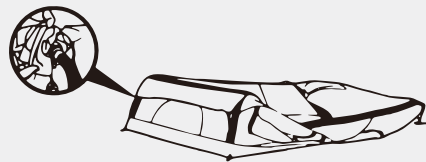

2. Conecte la bomba a la boquilla.

03

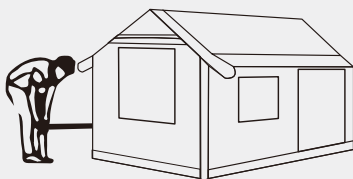

3. Bombee durante 3-5 minutos hasta que la tienda esté totalmente abierta y la columna esté firme.

04

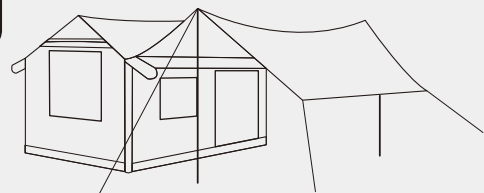

4. Clava bien los clavos, retira la cuerda de viento y asegúrala.

## TALLA

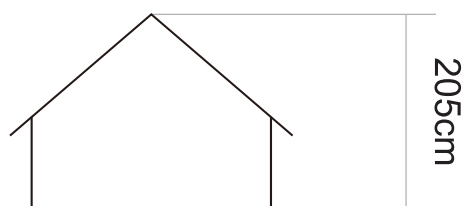
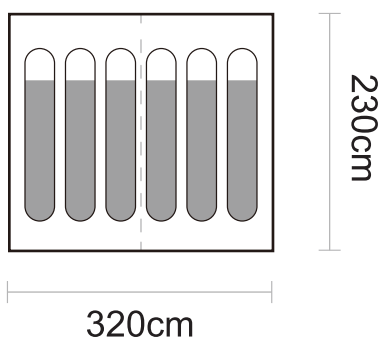

## ACCESORIO

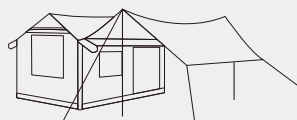

Tenda\*1

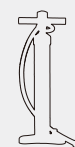
Bolsa de  
almacenami  
ento\*1Estaca  
para  
tienda\*24Cuerda de  
viento\*8Asta de  
tienda\*2Bomba  
limitadora de  
presión\*1

## ATENÇÃO

- Por favor, verifique o manual cuidadosamente e certifique-se de que recebeu todas as peças.
- Se faltar alguma, informe-nos a letra da peça que precisa.
- Se houver algum dano, envie-nos fotos claras e nós verificaremos e ofereceremos a melhor solução em breve.

## ETAPAS DE INSTALAÇÃO

01

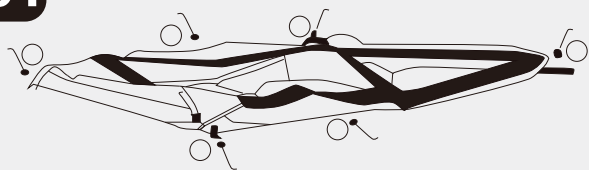

1. Desdobre a tenda e fixe as 6 posições no chão com pregos de aço.

02

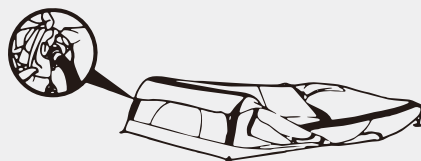

2. Conecte a bomba ao bocal.

03

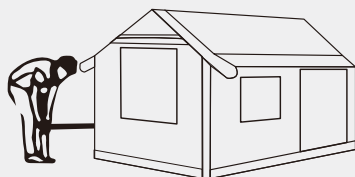

3. Bombeie por 3–5 minutos até que a tenda esteja totalmente aberta e a coluna esteja firme.

04

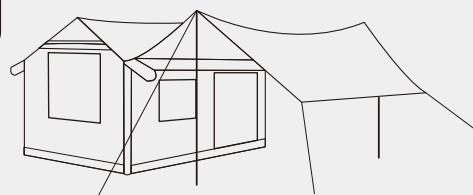

4. Enfie bem as unhas, puxe a corda do vento para trás e a prenda.

## TAGLIA

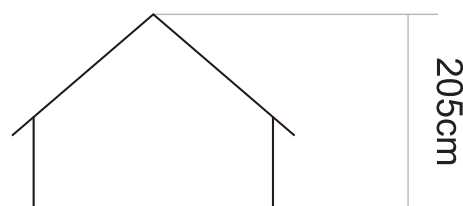
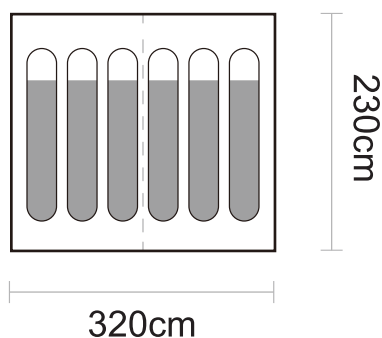

## ACCESSORIO

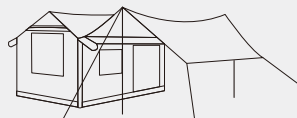

Tenda\*1



Sacca per il trasporto\*1



Picchetto per tenda\*24



Cima per vento\*8



Asta per tenda\*2

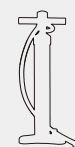

Pompa limitatrice di pressione\*1

## ATTENZIONE

- Si prega di controllare attentamente il manuale e assicurarsi di aver ricevuto tutte le parti.
- Se manca qualcosa, vi preghiamo di comunicarci la lettera delle parti di cui avete bisogno.
- Se ci sono danni, inviateci foto chiare e provvederemo a verificare e offrirvi la migliore soluzione al più presto.

## PASSAGGI DI INSTALLAZIONE

01

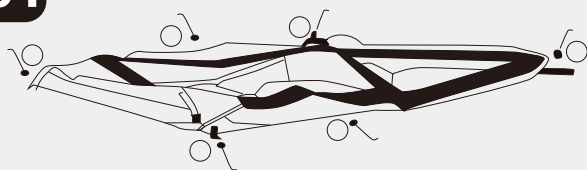

1. Aprire la tenda e fissare i 6 punti a terra con chiodi in acciaio.

02

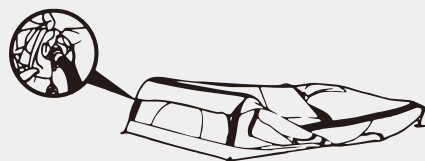

2. Collegare la pompa all'ugello.

03

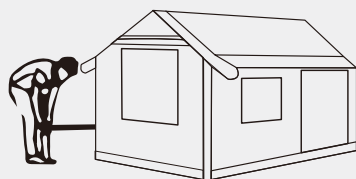

3. Pompate per 3-5 minuti fino a quando la tenda non è completamente aperta e la colonna è ferma.

04

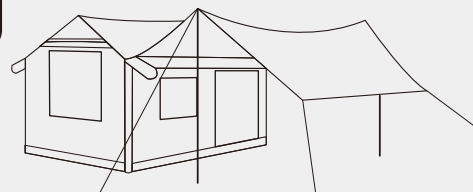

4. Fissare bene i chiodi, staccare la corda antivento e assicurarla.

**US**

If you have any questions, please contact our customer care center.

Our contact details are below:

 001-877-644-9366

 customerservice@aosom.com

Imported by Aosom LLC

27150 SW Kinsman Rd Wilsonville, OR 97070 USA

MADE IN CHINA

**ES**

Si tiene alguna pregunta, comuníquese con nuestro Centro de Atención al Cliente.

Nuestros datos de contacto son los siguientes:

 0034-931294512

 atencioncliente@aosom.es

Importador/Fabricante/REP:

Spanish Aosom, S.L.

C/ Roc Gros, nº 15. 08550, Els Hostalets de Balenyà, Spain.

B66295775

atencioncliente@aosom.es

TEL: 931294512

HECHO EN CHINA

**CA**

If you have any questions, please contact our customer care center.

Our contact details are below:

 416-792-6088

 customerservice@aosom.ca

Imported by Aosom Canada Inc.

7270 Woodbine Avenue, Unit 307, Markham,

Ontario Canada

L3R 4B9

MADE IN CHINA

Si vous avez la moindre question, veuillez contacter notre centre d'assistance à la clientèle.

Nos coordonnées sont les suivantes:

 416-792-6088

 customerservice@aosom.ca

Importé par Aosom Canada Inc.

7270 Woodbine Avenue, unité 307,

Markham, Ontario Canada

L3R 4B9

FABRIQUÉ EN CHINE

**PT**

Se tiver alguma dúvida, por favor contacte o nosso Centro de Atendimento ao Cliente.

Os nossos dados de contacto são os seguintes:

 0034-931294512 (SEG-SEX DAS 7:30H ÀS 16:30H)

 info@aosom.pt.

IMPORTADOR:

SPANISH AOSOM, S.L



C.ROC GROS N.15, 08550. ELS HOSTALETES DE BALENYÀ

WWW.AOSOM.PT

**DE**

Wenn Sie Fragen haben, wenden Sie sich bitte an unser Kundendienstzentrum.

Unsere Kontaktdaten stehen unten:

 0049-0(40)-87408465  service@aosom.de

Importeur/Hersteller/REP:

MH Handel GmbH

Wendenstraße 309

D-20537 Hamburg

Germany

IN CHINA HERGESTELLT

**UK**

If you have any questions, please contact our customer care center.

Our contact details are below:

 0044-800-240-4004

 enquiries@mhstar.co.uk

IMPORTER ADDRESS:

MH STAR UK LTD

Unit 27, Perivale Park,

Horsenden lane South

Perivale, UB6 7RH

MADE IN CHINA

**IT**

In caso di dubbio, si prega di contattare il nostro centro assistenza clienti.

I nostri dettagli di contatto sono di seguito:

 0039-0249471447  clienti@aosom.it

IMPORTATO DA/Produttore/REP:

AOSOM Italy srl

Centro Direzionale Milanofiori

Strada 1 Palazzo F1

20057 Assago (MI)

P.I.: 08567220960

FATTO IN CINA

**FR**

Si vous avez la moindre question, veuillez contacter notre centre d'assistance à la clientèle.

Nos coordonnées sont les suivantes:

 0033-1-84166106

 aosom@mhfrance.fr

Importé par/Fabricant/REP:

MH France

2, rue Maurice Hartmann

92130 Issy-les-Moulineaux

France

Fabriqué en Chine

**FR**

**DONNEZ**  
OU  
**RECYCLEZ**



OU

ASSOCIATION



OU

LIVRAISON



DÉCHÈTERIE

Adresses sur quefairedemesdechets.fr

