

**Collapsible sensor bin/Poubelle à capteur pliable/
Faltbarer Sensor-Mülleimer/Cubo de sensor plegable/
Lixeira com sensor dobrável/Cestino sensoriale pieghevole**

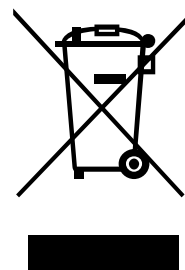

30L/40L/50L/60L

EN_IMPORTANT, RETAIN FOR FUTURE REFERENCE: READ CAREFULLY.

**FR_IMPORTANT : A LIRE ATTENTIVEMEN ET A CONSERVER POUR VOUS Y REFERER
ULTERIEUREMENT**

ES_IMPORTANTE, LEA Y GUARDE PARA FUTURAS REFERENCIAS.

PT_IMPORTANTE, RETAR PARA REFERÉNCIA FUTURA: LEIA ATENTAMENTE.

DE_WICHTIG! SORGFÄLTIG LESEN UND FÜR SPÄTER NACHSCHLAGEN AUFBEWAHREN.

**IT_IMPORTANTE! CONSERVARE IL PRESENTE MANUALE PER FUTURO RIFERIMENTO E
LEggerlo ATTENTAMENTE.**

Product Information

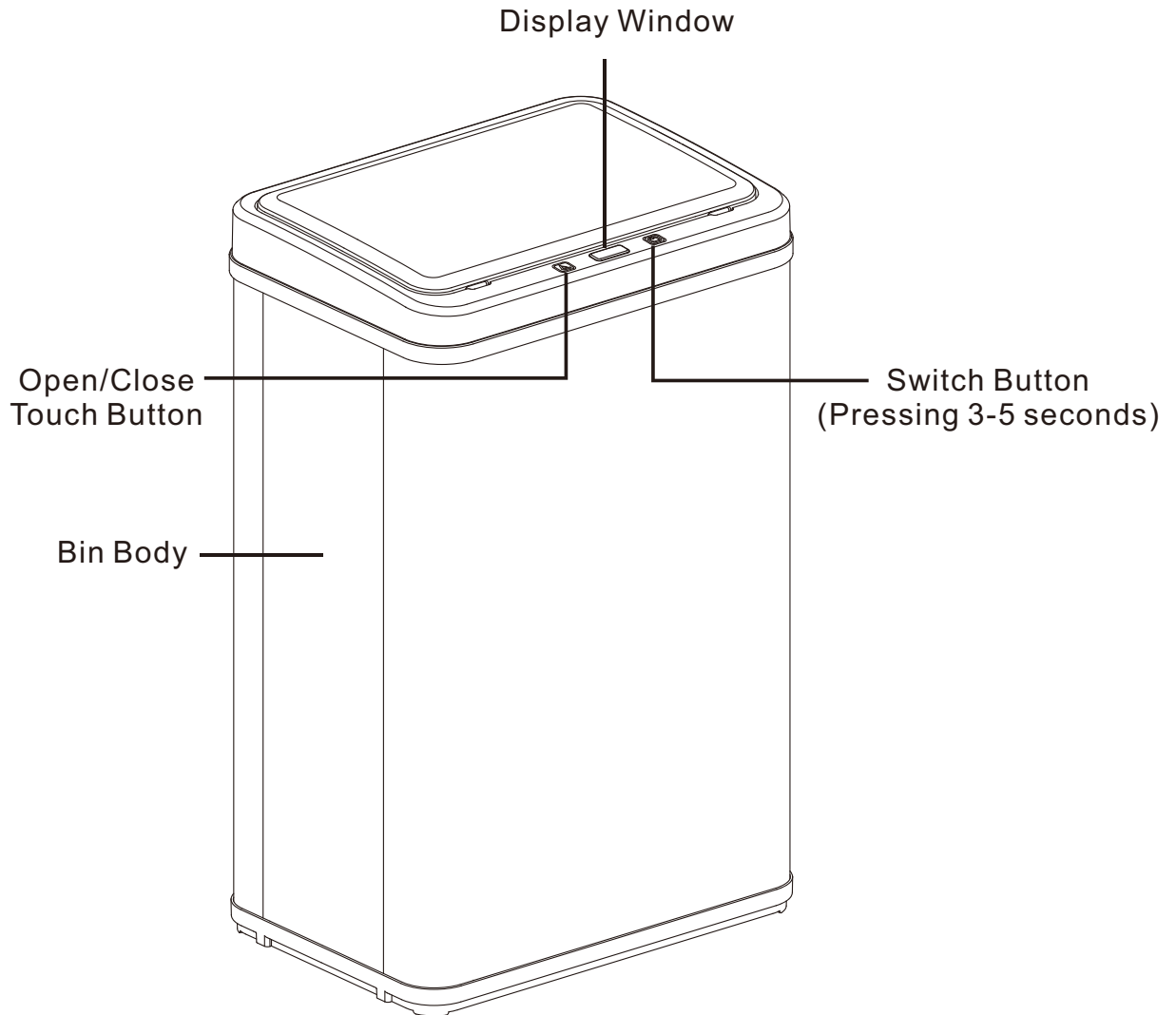

Volume	Dimensions	Power
30L	35.5*26*43.5cm	4*AA batteries(Not included)
40L	35.5*26*55cm	4*AA batteries(Not included)
50L	35.5*26*67cm	4*AA batteries(Not included)
60L	35.5*26*79cm	4*AA batteries(Not included)

Safety Cautions

Before using, please carefully read the safety checkpoints.

Related signs

For the safety of you and others, please abide by the safety caution check points.



Injury may be caused or the dustbin may break down by wrong operation

CAUTION

Example of signs

Signs are used to indicate and explain the items you must abide by.



This means forbidden.









This means you must do it.

Keep these points in mind as you read through.





CAUTION

 <p>Not to be flushed with water because of the electric and electronic components. Can be wiped with wet wipes on surface.</p>	 <p>Avoid direct casting of sunshine on the induction receiver window</p>
 <p>During the opening process of the cover, don't press the cover with force.</p>	 <p>Dismantling, repair and alteration of the product are absolutely</p>
 <p>When batteries are going run out, please replace with new ones instantly</p>	 <p>Don't put anything on the dustbin cover</p>

- This appliance can be used by children aged from 8 years and above and persons with reduced physical, sensory or mental capabilities or lack of experience and knowledge if they have been given supervision or instruction concerning use of the appliance in a safe way and understand the hazards involved.
- Children shall not play with the appliance.
- Cleaning and user maintenance shall not be made by children without supervision.
- Different types of batteries or new and used batteries are not to be mixed;
- Batteries are to be inserted with the correct polarity;
- Exhausted batteries are to be removed from the appliance and safely disposed of;
- If the appliance is to be stored unused for a long period, the batteries should be removed;
- The supply terminals are not to be short-circuited.

Operation Instruction

- (1) Open the battery cover at the bottom of the lid and insert 4pcs#AA batteries according to the correct polarity, then close the battery cover.
- (2) Turn on the power switch on the lid-Pressing 3-5 seconds, then the indicator will turn green for 3 seconds(Approx).When the indicator twinkles green 3 times, it means the electronic circuit is waiting in a normal status.
- (3) When you need to toss the garbage into the bin, simply hover your hand above the lid within 15-25cm and it will open. The lid will then close after 5 seconds of inactivity. The cover will keep open if your hand or object stays in the induction area.
- (4) To manually open and close the lid cover, press  button at the induction window(manual open-cover button), and the cover opens up but it will not close. This feature is for use when you frequently put trash in. To close the cover also press  button, and there after the circuit resumes its automatic induction function.
- (5) When the cover automatically open, the indicator is green, after 5 seconds the cover will close automatically, the indicator twinkle red once; And when you use manual open-coverfunction, the indicator twinkle in green once, press close twinkle red once, the cover will close.
- (6) If the dustbin opens and closes for 20 rounds per day, the battery can serve 3 months(approx).

Informations sur le produit

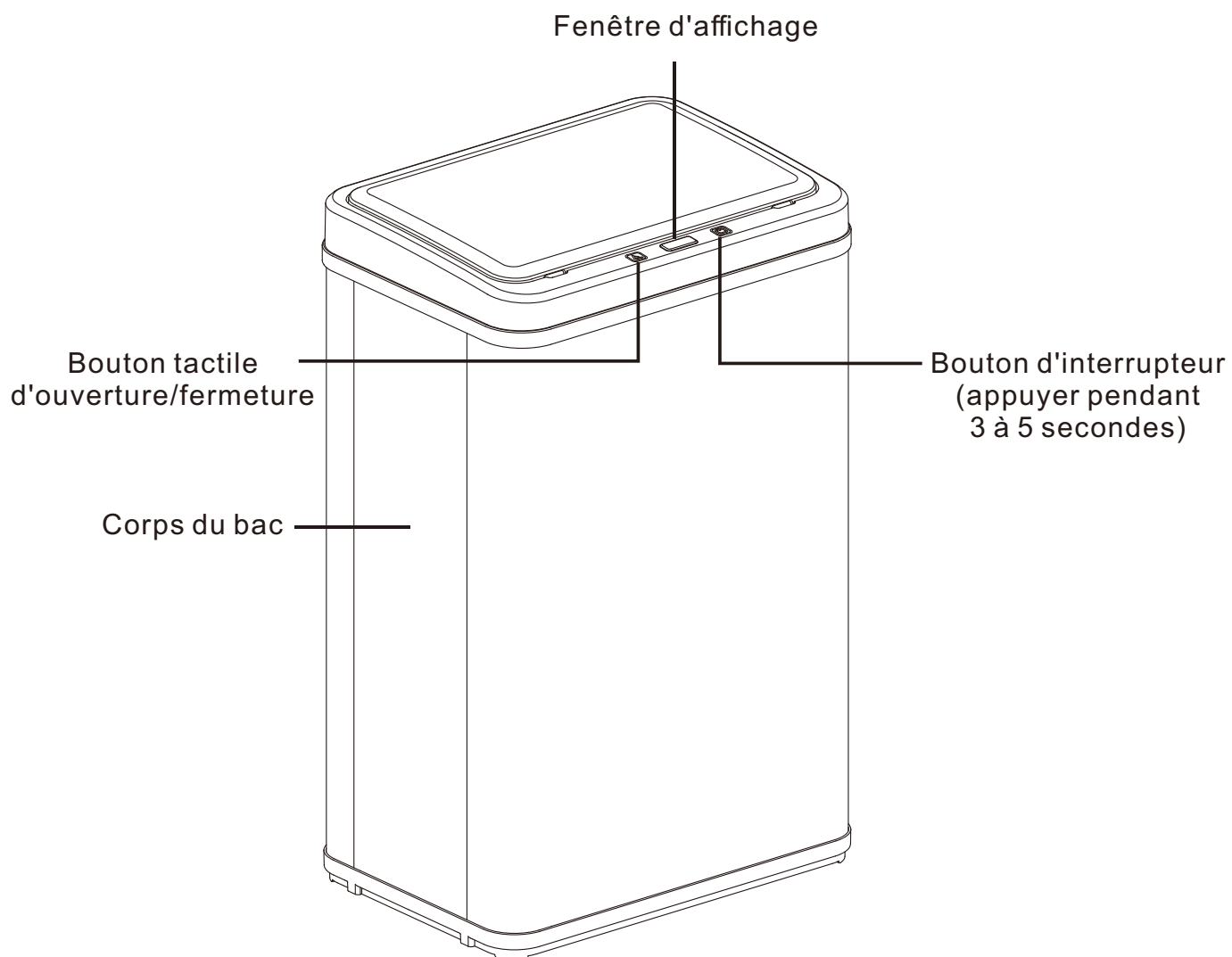

Volume	Dimensions	Alimentation
30L	35.5*26*43.5cm	4 piles AA (non fournies)
40L	35.5*26*55cm	4 piles AA (non fournies)
50L	35.5*26*67cm	4 piles AA (non fournies)
60L	35.5*26*79cm	4 piles AA (non fournies)

Mises en Garde de Sécurité

Avant toute utilisation, veuillez lire attentivement les mesures de sécurité.

Symboles Pertinents

Les mises en garde de sécurité ont pour but d'éviter des dommages inutiles pour vous et pour les autres, et sont importantes en matière de sécurité. Veuillez vous y conformer.



Des blessures peuvent être causées ou la poubelle peut tomber en panne par erreur lors de son utilisation.

ATTENTION

Exemple de symboles

Les symboles servent à indiquer et à expliquer les éléments auxquels vous devez vous conformer.









Ceci réfère à une
INTERDICTION



Ceci réfère à une **OBLIGATION**



Veuillez bien retenir ces points après les avoir lus.

 ATTENTION			
	<p>Ce produit contient des composants électriques et électroniques, et ne peut pas être soumis à un nettoyage à l'eau, mais il peut être essuyé par des lingettes humides sur sa surface.</p>		<p>Éviter l'exposition directe aux rayons du soleil de la surface du récepteur à induction.</p>
	<p>Lors de l'ouverture du couvercle, ne pas exercer de pression sur le couvercle.</p>		<p>Le démontage, la réparation et la modification du produit sont strictement interdits.</p>
	<p>Remplacer immédiatement les piles usagées par des piles neuves.</p>		<p>Ne rien poser sur le couvercle de la poubelle.</p>

- Cet appareil peut être utilisé par des enfants à partir de 8 ans et plus et par des personnes ayant des capacités physiques, sensorielles ou mentales réduites ou un manque d'expérience et de connaissances à condition qu'elles aient reçu une supervision ou des instructions concernant l'utilisation de l'appareil en toute sécurité et qu'elles comprennent les dangers encourus.

- Les enfants ne doivent pas jouer avec l'appareil.
- Le nettoyage et l'entretien par l'utilisateur ne doivent pas être effectués par des enfants sans surveillance.
- Les différents types de batteries ou les batteries neuves et usagées ne doivent pas être mélangées;
- Les batteries doivent être insérées selon la polarité correcte;
- Les batteries déchargées doivent être retirées de l'appareil et éliminées de façon sûre;
- Si l'appareil doit être entreposé sans être utilisé pendant une longue période, il convient de retirer les batteries;
- Les bornes d'alimentation ne doivent pas être court-circuitées.

Mode d'Emploi

- (1) Ouvrez le couvercle du compartiment à piles situé au bas du couvercle et insérez 4 piles AA en respectant la polarité, puis refermez le couvercle.
- (2) Allumez l'interrupteur situé sur le couvercle en appuyant dessus pendant 3 à 5 secondes. Le voyant s'allume alors en vert pendant environ 3 secondes. Lorsque le voyant clignote 3 fois en vert, cela signifie que le circuit électronique est en veille dans un état normal.
- (3) Lorsque vous devez jeter des déchets dans la poubelle, il suffit de passer votre main au-dessus du couvercle à une distance de 15 à 25 cm pour qu'il s'ouvre. Le couvercle se refermera après 5 secondes d'inactivité. Le couvercle restera ouvert si votre main ou un objet reste dans la zone d'induction.
- (4) Pour ouvrir et fermer manuellement le couvercle, appuyez sur le bouton  situé sur la fenêtre d'induction (bouton d'ouverture manuelle du couvercle). Le couvercle s'ouvrira, mais ne se refermera pas. Cette fonction est utile lorsque vous jetez fréquemment des déchets. Pour fermer le couvercle, appuyez également sur le bouton . Le circuit reprendra alors sa fonction d'induction automatique.
- (5) Lorsque le couvercle s'ouvre automatiquement, le voyant est vert. Après 5 secondes, le couvercle se refermera automatiquement et le voyant clignotera une fois en rouge. Lorsque vous utilisez la fonction d'ouverture manuelle du couvercle, le voyant clignotera une fois en vert, puis clignotera une fois en rouge lorsque vous appuierez sur le bouton de fermeture. Le couvercle se refermera alors.
- (6) Si la poubelle s'ouvre et se ferme 20 fois par jour, la batterie aura une autonomie d'environ 3 mois.

Información del producto

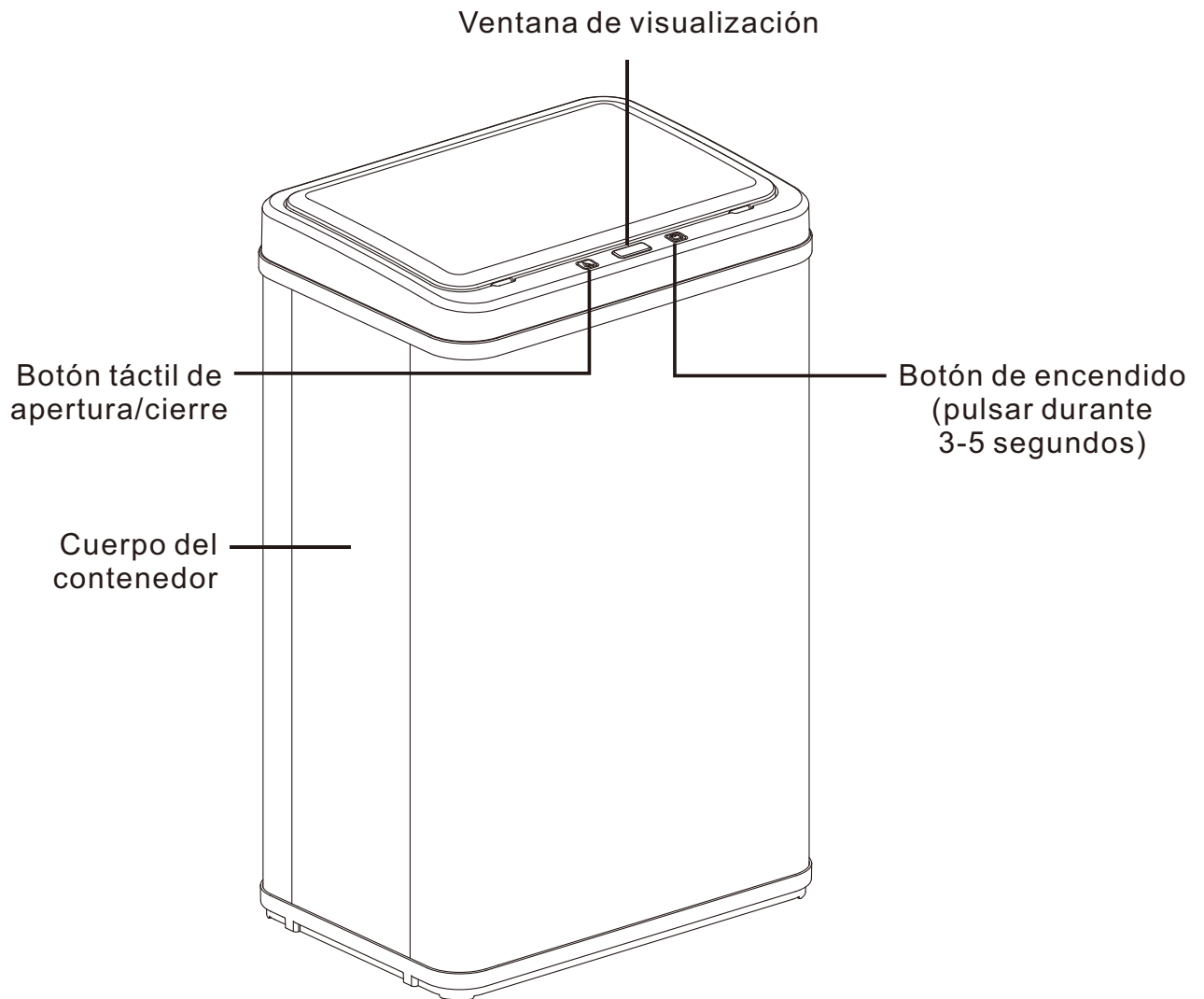

Volumen	Dimensiones	Alimentación
30L	35.5*26*43.5cm	4 pilas AA (no incluidas)
40L	35.5*26*55cm	4 pilas AA (no incluidas)
50L	35.5*26*67cm	4 pilas AA (no incluidas)
60L	35.5*26*79cm	4 pilas AA (no incluidas)

Precauciones de seguridad

Antes de usar, lea atentamente los puntos de control de seguridad.

Símbolos relacionados

Las advertencias de seguridad están destinadas a evitar daños innecesarios a usted y a otros, y son importantes para la seguridad. Por favor, respételes.



Un mal uso del producto puede causar lesiones o que el cubo se averíe.

ADVERTENCIA

Ejemplo de símbolos

Los símbolos se utilizan para indicar y explicar los elementos que se deben cumplir.



Esto significa prohibido









Esto significa que debes hacerlo

Recuerde los puntos después de leerlos.





ADVERTENCIAS

 <p>Este producto contiene componentes eléctricos. No se puede enjuagar con agua, pero se puede limpiar con toallitas húmedas en su superficie.</p>	 <p>Evite la proyección directa de la luz solar sobre la ventana del receptor de inducción.</p>
 <p>Durante el proceso de apertura de la tapa, no presione la tapa con fuerza.</p>	 <p>Queda terminantemente prohibido el desmontaje y la reparación y alteración del producto.</p>
 <p>Cuando la batería se vaya a agotar, reemplácela por una nueva al instante.</p>	 <p>No coloque nada sobre la tapa del cubo de basura.</p>

- Este aparato puede ser utilizado por niños mayores de 8 años y personas con capacidades físicas, sensoriales o mentales reducidas o con falta de experiencia y conocimientos, siempre que hayan recibido supervisión o instrucciones sobre el uso seguro del aparato y comprendan los riesgos que conlleva.
- Los niños no deben jugar con el aparato.
- La limpieza y el mantenimiento por parte del usuario no deben ser realizados por niños sin supervisión.
- No deben mezclarse diferentes tipos de pilas ni pilas nuevas y usadas.
- Las pilas deben insertarse con la polaridad correcta.
- Las pilas agotadas deben retirarse del aparato y desecharse de forma segura.
- Si el aparato va a permanecer sin utilizarse durante un periodo prolongado, deben retirarse las pilas.
- No deben cortocircuitarse los terminales de alimentación.

Instrucciones de uso

- (1) Abra la tapa de la batería situada en la parte inferior de la cubierta e inserte 4 pilas AA respetando la polaridad correcta, luego cierre la tapa de la batería.
- (2) Encienda el interruptor de encendido situado en la cubierta: mantenga pulsado durante 3-5 segundos y el indicador se iluminará en verde durante 3 segundos (aproximadamente). Cuando el indicador parpadee en verde 3 veces, significa que el circuito electrónico está en estado de espera normal.
- (3) Cuando necesite tirar la basura al cubo, simplemente pase la mano por encima de la tapa a una distancia de entre 15 y 25 cm y esta se abrirá. La tapa se cerrará tras 5 segundos de inactividad. La tapa permanecerá abierta si su mano u otro objeto permanece en la zona de inducción.
- (4) Para abrir y cerrar manualmente la tapa, pulse el botón  de la ventana de inducción (botón de apertura manual de la tapa) y la tapa se abrirá, pero no se cerrará. Esta función se utiliza cuando se tira basura con frecuencia. Para cerrar la tapa, pulse también el botón  y, a continuación, el circuito reanudará su función de inducción automática.
- (5) Cuando la tapa se abre automáticamente, el indicador se ilumina en verde y, tras 5 segundos, la tapa se cerrará automáticamente y el indicador parpadeará una vez en rojo. Cuando utilice la función de apertura manual de la tapa, el indicador parpadeará una vez en verde y, al pulsar el botón de cierre, parpadeará una vez en rojo y la tapa se cerrará.
- (6) Si el cubo de basura se abre y se cierra 20 veces al día, la batería tendrá una duración aproximada de 3 meses.

Informações sobre o produto

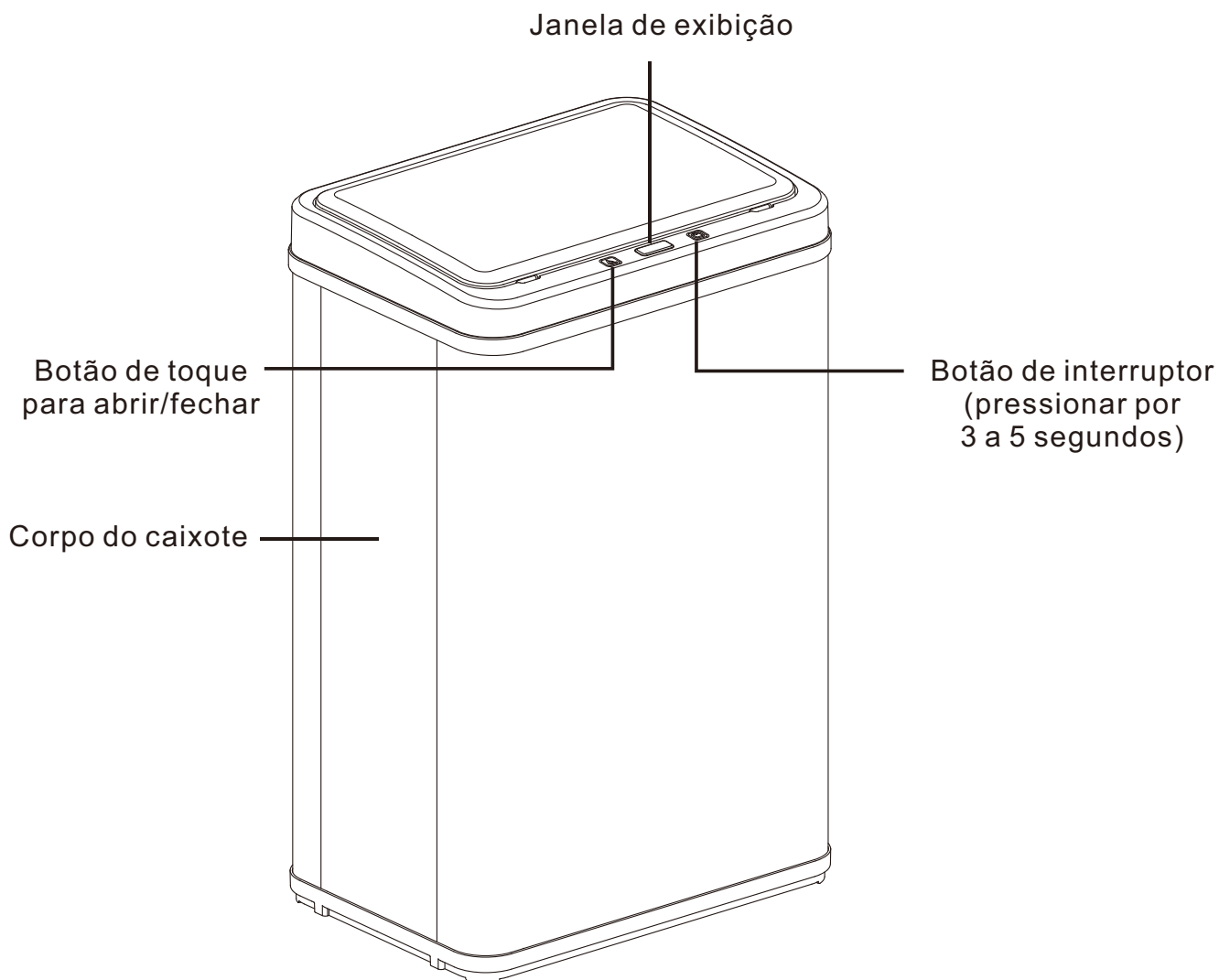

Volume	Dimensões	Alimentação
30L	35.5*26*43.5cm	4 pilhas AA (não incluídas)
40L	35.5*26*55cm	4 pilhas AA (não incluídas)
50L	35.5*26*67cm	4 pilhas AA (não incluídas)
60L	35.5*26*79cm	4 pilhas AA (não incluídas)

Precauções de segurança

Antes de usar, leia atentamente os pontos de verificação de segurança.

Símbolos relacionados

Os avisos de segurança destinam-se a evitar danos desnecessários a si e a outras pessoas e são importantes para a segurança. Por favor, respeite-os.



ATENÇÃO

O uso indevido do produto pode causar ferimentos ou danos ao balde de lixo.

Exemplo de símbolos

Os símbolos são utilizados para indicar e explicar itens que devem ser cumpridos.



Isso significa proibido









Isso significa que você deve fazer

Lembre-se dos pontos depois de lê-los.





AVISOS

 <p>Este produto contém componentes elétricos. Não pode ser enxaguado com água, mas pode ser limpo com lenços umedecidos em sua superfície.</p>	 <p>Evite a projeção direta da luz solar na janela do receptor de indução.</p>
 <p>Durante o processo de abertura da tampa, não pressione a tampa com força.</p>	 <p>A desmontagem, reparação e alteração do produto é estritamente proibida.</p>
 <p>Quando a bateria acabar, substitua-a por uma nova instantaneamente.</p>	 <p>Não coloque nada em cima da tampa do balde do lixo.</p>

- Este aparelho pode ser utilizado por crianças com idade igual ou superior a 8 anos e por pessoas com capacidades físicas, sensoriais ou mentais reduzidas ou com falta de experiência e conhecimento, desde que tenham recebido supervisão ou instruções sobre a utilização segura do aparelho e compreendam os riscos envolvidos.
- As crianças não devem brincar com o aparelho.
- A limpeza e a manutenção pelo utilizador não devem ser realizadas por crianças sem supervisão.
- Não se devem misturar diferentes tipos de pilhas ou pilhas novas e usadas;
- As pilhas devem ser inseridas com a polaridade correta;
- As pilhas gastas devem ser removidas do aparelho e eliminadas de forma segura;
- Se o aparelho for armazenado sem utilização durante um longo período, as pilhas devem ser removidas;
- Os terminais de alimentação não devem ser colocados em curto-circuito.

Instruções de utilização

- (1) Abra a tampa da bateria na parte inferior da tampa e insira 4 pilhas AA de acordo com a polaridade correta, depois feche a tampa da bateria.
- (2) Ligue o interruptor de alimentação na tampa - pressione por 3-5 segundos, então o indicador ficará verde por 3 segundos (aproximadamente). Quando o indicador piscar verde 3 vezes, significa que o circuito eletrónico está à espera num estado normal.
- (3) Quando precisar de deitar o lixo no caixote, basta passar a mão por cima da tampa a uma distância de 15 a 25 cm e ela abrirá. A tampa fechará após 5 segundos de inatividade. A tampa permanecerá aberta se a sua mão ou objeto permanecer na área de indução.
- (4) Para abrir e fechar manualmente a tampa, pressione o botão  na janela de indução (botão de abertura manual da tampa) e a tampa abrirá, mas não fechará. Esse recurso deve ser usado quando você coloca lixo com frequência. Para fechar a tampa, pressione novamente o botão  e, em seguida, o circuito retomará sua função de indução automática.
- (5) Quando a tampa abre automaticamente, o indicador fica verde e, após 5 segundos, a tampa fecha automaticamente e o indicador pisca uma vez em vermelho. Quando utiliza a função de abertura manual da tampa, o indicador pisca uma vez em verde e, ao pressionar fechar, pisca uma vez em vermelho e a tampa fecha.
- (6) Se o caixote do lixo abrir e fechar 20 vezes por dia, a bateria pode durar 3 meses (aproximadamente).

Produktinformationen

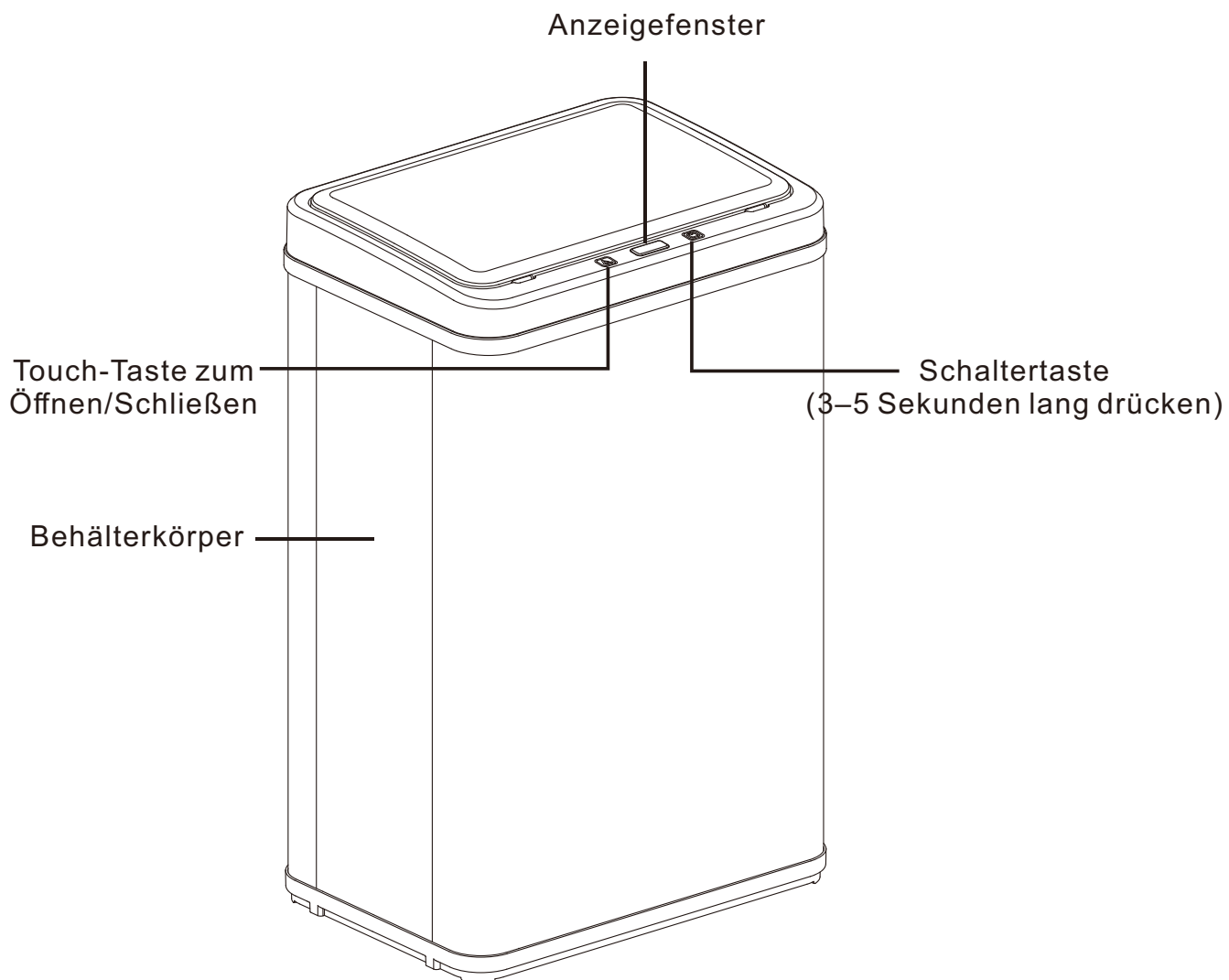

Lautstärke	Abmessungen	Stromversorgung
30L	35.5*26*43.5cm	4 AA-Batterien (nicht im Lieferumfang enthalten)
40L	35.5*26*55cm	4 AA-Batterien (nicht im Lieferumfang enthalten)
50L	35.5*26*67cm	4 AA-Batterien (nicht im Lieferumfang enthalten)
60L	35.5*26*79cm	4 AA-Batterien (nicht im Lieferumfang enthalten)

Sicherheitshinweise

Bitte lesen Sie sich die folgenden Sicherheitshinweise sorgfältig durch, bevor Sie das Produkt benutzen.

Relevante Symbole

Befolgen Sie bitte die Sicherheitshinweise, um Ihre und die Sicherheit von anderen zu gewährleisten.



ACHTUNG

Falsche Handhabung des Produkts kann zu Defekt und/oder Verletzungen führen.

Symbolerklärung

Symbole werden verwendet um Handlungen zu erklären, die befolgt werden müssen.



Dieses Symbol kennzeichnet eine verbotene Handlung.









Dieses Symbol kennzeichnet eine Handlung die vollzogen werden muss.

Lesen Sie die folgenden Punkte sorgfältig durch und merken sie sich.





ACHTUNG

 <p>Darf nicht mit Wasser gewaschen werden, wegen empfindlichen elektrischen Bestandteilen. Die Oberfläche kann mit Feuchttücher gewischt werden.</p>	 <p>Vermeiden Sie direktes Sonnenlicht auf den Induktionsbildschirm.</p>
 <p>Zwingen Sie den Deckel nicht mit Gewalt auf, während des automatischen Öffnungsprozess.</p>	 <p>Der Umbau, die Reparatur und Veränderungen am Gerät sind strikt verboten.</p>
 <p>Falls die Batterien zur Neige gehen, wechseln Sie sie bitte umgehend mit neuen aus.</p>	 <p>Stellen Sie nichts auf den Deckel des Produkts.</p>

- Dieses Gerät kann von Kindern ab 8 Jahren und darüber sowie von Personen mit verringerten physischen, sensorischen oder mentalen Fähigkeiten oder Mangel an Erfahrung und Wissen benutzt werden, wenn sie beaufsichtigt oder bezüglich des sicheren Gebrauchs des Gerätes unterwiesen wurden und die daraus resultierenden Gefahren verstehen.

- Kinder dürfen nicht mit dem Gerät spielen.
- Reinigung und Benutzer-Wartung dürfen nicht von Kindern ohne Beaufsichtigung durchgeführt werden.
- Unterschiedliche Batterie- bzw. Akkutypen sowie neue und alte Batterien dürfen nicht gemischt eingesetzt werden.
- Batterien stets polrichtig einsetzen, da sonst die Gefahr des Platzens besteht.
- Entfernen Sie verbrauchte Batterien umgehend und entsorgen Sie diese umweltgerecht.
- Entnehmen Sie die Batterien aus dem Gerät, wenn Sie es längere Zeit nicht benutzen oder es lagern wollen.
- Die Anschlussklemmen dürfen nicht kurzgeschlossen werden.

Bedienungsanleitung

- (1) Öffnen Sie die Batterieabdeckung an der Unterseite des Deckels und legen Sie 4 Stück AA-Batterien entsprechend der richtigen Polarität ein. Schließen Sie anschließend die Batterieabdeckung.
- (2) Schalten Sie den Netzschalter am Deckel ein, indem Sie ihn 3–5 Sekunden lang drücken. Die Anzeige leuchtet dann ca. 3 Sekunden lang grün. Wenn die Anzeige dreimal grün blinkt, bedeutet dies, dass sich der elektronische Schaltkreis im Normalzustand befindet.
- (3) Wenn Sie den Müll in den Behälter werfen möchten, halten Sie einfach Ihre Hand in einem Abstand von 15 bis 25 cm über den Deckel, und dieser öffnet sich. Der Deckel schließt sich nach 5 Sekunden Inaktivität wieder. Der Deckel bleibt offen, wenn Ihre Hand oder ein Gegenstand im Induktionsbereich verbleibt.
- (4) Um den Deckel manuell zu öffnen und zu schließen, drücken Sie die Taste  am Induktionsfenster (manuelle Öffnungstaste). Der Deckel öffnet sich, schließt sich jedoch nicht wieder. Diese Funktion ist für den Fall gedacht, dass Sie häufig Müll entsorgen. Um den Deckel zu schließen, drücken Sie ebenfalls die Taste . Danach nimmt der Schaltkreis seine automatische Induktionsfunktion wieder auf.
- (5) Wenn sich der Deckel automatisch öffnet, leuchtet die Anzeige grün. Nach 5 Sekunden schließt sich der Deckel automatisch und die Anzeige blinkt einmal rot. Wenn Sie die manuelle Öffnungsfunktion verwenden, blinkt die Anzeige einmal grün, die Schließen-Taste blinkt einmal rot und der Deckel schließt sich.
- (6) Wenn der Mülleimer 20 Mal pro Tag geöffnet und geschlossen wird, hält die Batterie etwa 3 Monate.

Informazioni sul prodotto

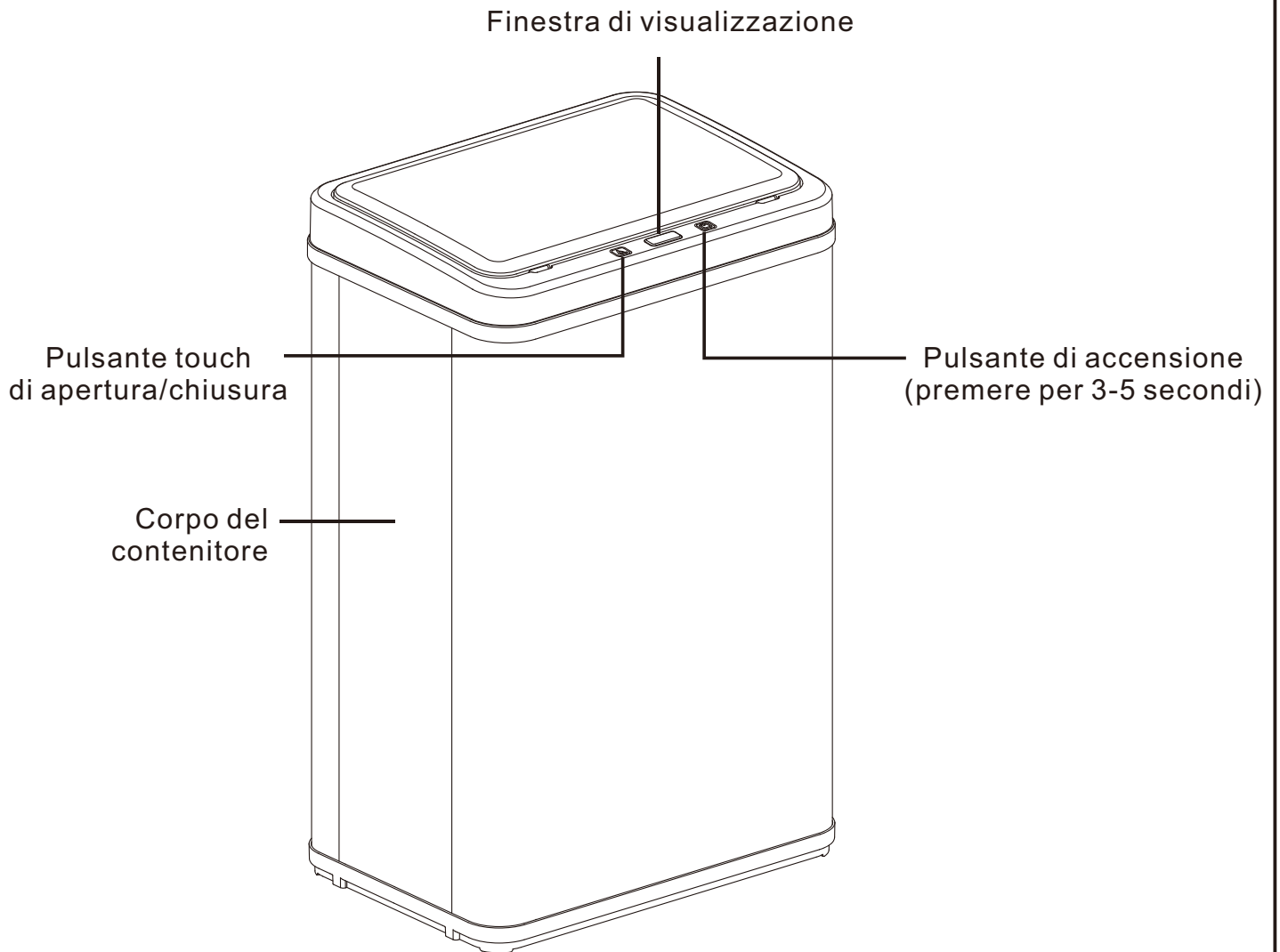

Volume	Dimensioni	Alimentazione
30L	35.5*26*43.5cm	4 batterie AA (non incluse)
40L	35.5*26*55cm	4 batterie AA (non incluse)
50L	35.5*26*67cm	4 batterie AA (non incluse)
60L	35.5*26*79cm	4 batterie AA (non incluse)

Avvertenze di Sicurezza

Prima di utilizzare, leggere attentamente le istruzioni di sicurezza.

Segni correlati

Le istruzioni di sicurezza da controllare intendono evitare danni inutili a te e agli altri e sono importanti per la sicurezza. Si prega di attenersi a loro.



ATTENZIONE

Le lesioni potrebbero verificarsi o la pattumiera potrebbe rompersi per errore durante il funzionamento

Esempi di segni

I segni sono usati per indicare e spiegare gli aspetti a cui devi attenerti.



Questo significa proibito.







Questo significa che devi farlo.

Si prega di ricordare i punti dopo averli letti.





ATTENZIONE

 <p>Questo prodotto contiene componenti elettrici ed elettronici e non può essere lavato con acqua, ma può essere pulito con panni bagnati sulla sua superficie.</p>	 <p>Evitare la luce solare diretta sulla finestra del ricevitore a induzione.</p>
 <p>Durante il processo di apertura del coperchio, non premere il coperchio con forza.</p>	 <p>Sono assolutamente vietati lo smontaggio, la riparazione e l'alterazione del prodotto</p>
 <p>Quando la batteria sta per esaurirsi, sostituirla immediatamente con una nuova.</p>	 <p>Non posizionare nulla sul coperchio della pattumiera</p>

- Questo apparecchio può essere utilizzato da bambini di età superiore agli 8 anni e da persone con ridotte capacità fisiche, sensoriali o mentali o con mancanza di esperienza e conoscenza, purché siano state fornite loro istruzioni o supervisione relative all'uso sicuro dell'apparecchio e comprendano i pericoli connessi.

- I bambini non devono giocare con l'apparecchio.
- La pulizia e la manutenzione da parte dell'utente non devono essere effettuate da bambini senza supervisione.
- non devono essere mescolati tipi diversi di batterie o batterie nuove e usate;
- le batterie devono essere inserite con la polarità corretta;
- le batterie esaurite devono essere rimosse dall'apparecchio e smaltite in modo sicuro;
- se l'apparecchio deve essere conservato inutilizzato per un lungo periodo, le batterie devono essere rimosse;
- i terminali di alimentazione non devono essere cortocircuitati.

Istruzioni Operative

- (1) Aprire il coperchio della batteria nella parte inferiore del coperchio e inserire 4 batterie AA rispettando la polarità corretta, quindi chiudere il coperchio della batteria.
- (2) Accendere l'interruttore di alimentazione sul coperchio premendo per 3-5 secondi, quindi l'indicatore diventerà verde per 3 secondi (circa). Quando l'indicatore lampeggia 3 volte in verde, significa che il circuito elettronico è in attesa in uno stato normale.
- (3) Quando è necessario gettare i rifiuti nel cestino, è sufficiente avvicinare la mano al coperchio a una distanza compresa tra 15 e 25 cm e questo si aprirà. Il coperchio si chiuderà dopo 5 secondi di inattività. Il coperchio rimarrà aperto se la mano o un oggetto rimangono nell'area di induzione.
- (4) Per aprire e chiudere manualmente il coperchio, premere il pulsante  sulla finestra di induzione (pulsante di apertura manuale del coperchio) e il coperchio si aprirà ma non si chiuderà. Questa funzione è utile quando si gettano spesso rifiuti nel cestino. Per chiudere il coperchio, premere nuovamente il pulsante  e il circuito riprenderà la sua funzione di induzione automatica.
- (5) Quando il coperchio si apre automaticamente, l'indicatore è verde, dopo 5 secondi il coperchio si chiuderà automaticamente e l'indicatore lampeggerà una volta in rosso; quando si utilizza la funzione di apertura manuale del coperchio, l'indicatore lampeggerà una volta in verde, premere il pulsante di chiusura e lampeggerà una volta in rosso, il coperchio si chiuderà.
- (6) Se il cestino si apre e si chiude 20 volte al giorno, la batteria può durare circa 3 mesi.

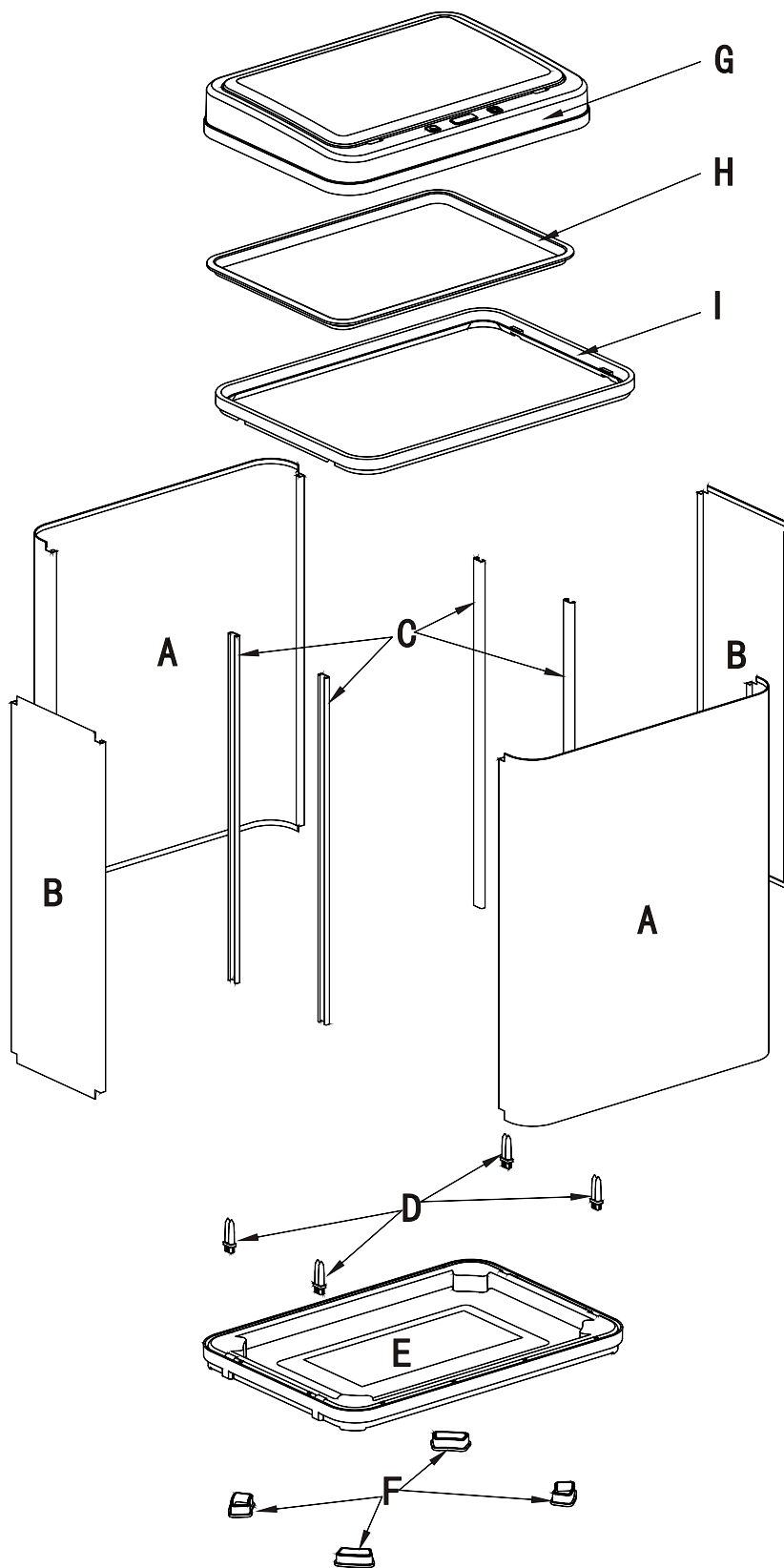

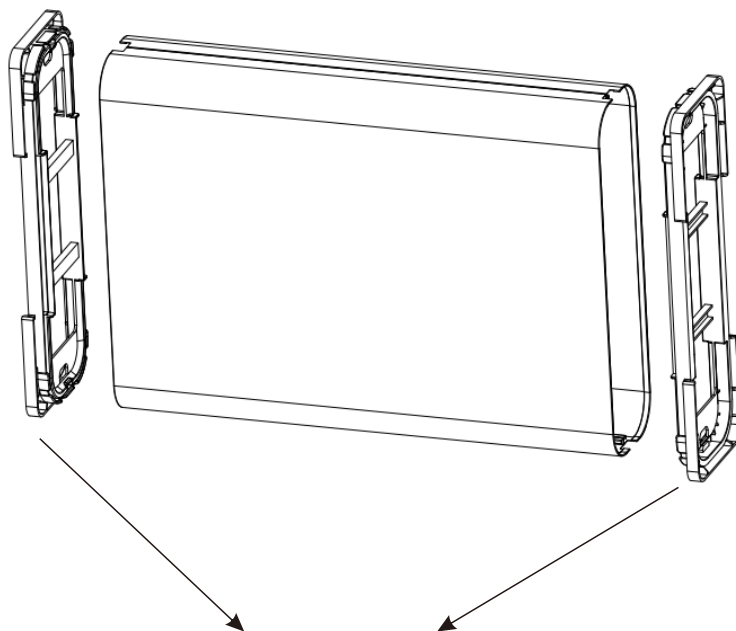

EN Plastic packaging components
FR Composants d'emballage en plastique
DE Kunststoffverpackungskomponenten
ES Componentes de envases de plástico
PT Componentes de embalagens plásticas
IT Componenti di imballaggio in plastica

01

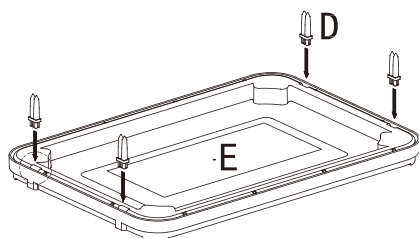

02

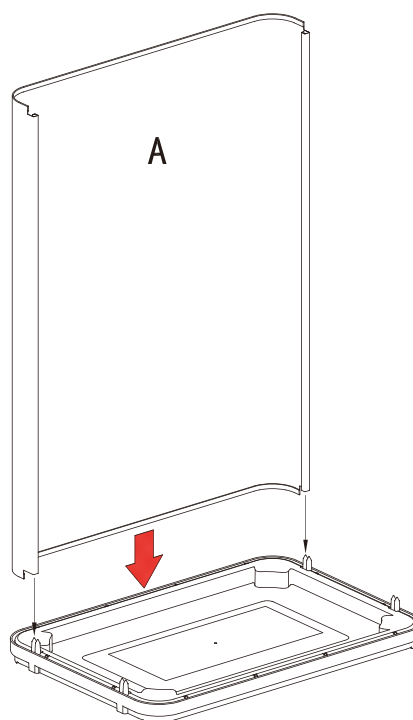

03

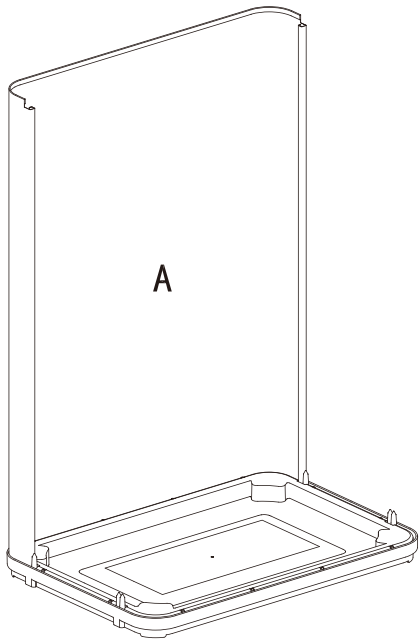

04

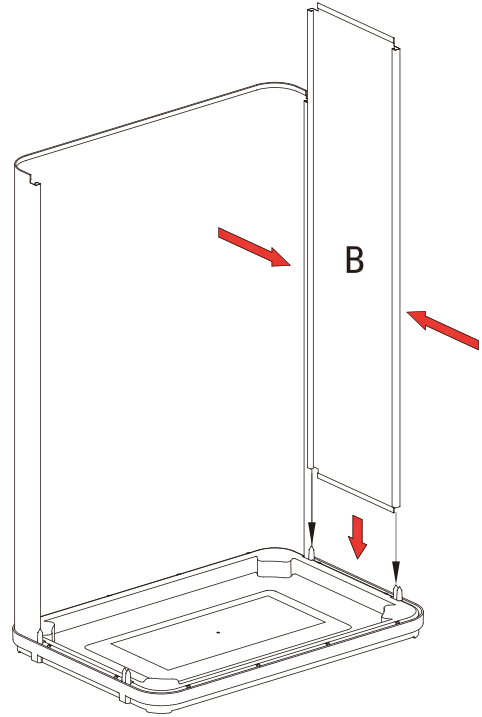

05

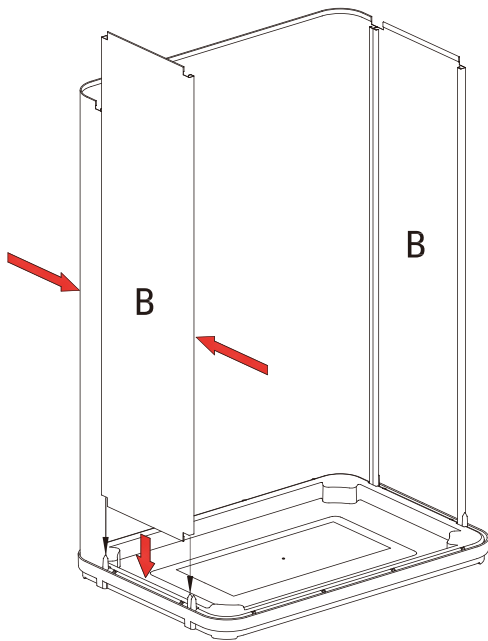

06

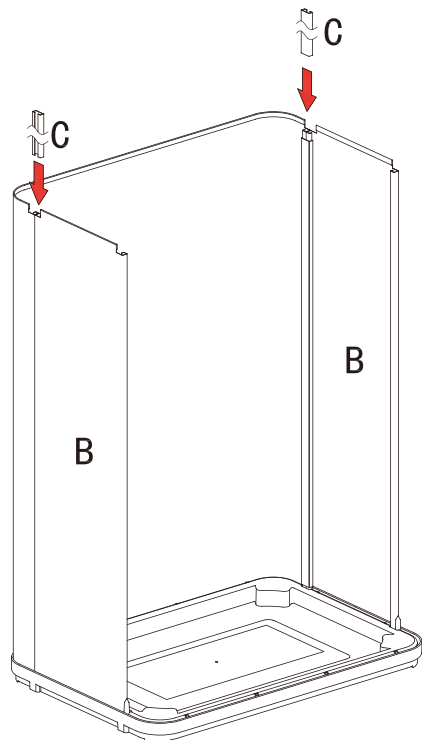

07

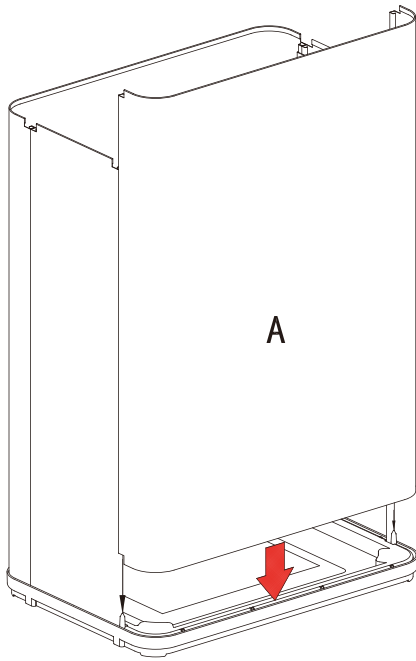

08

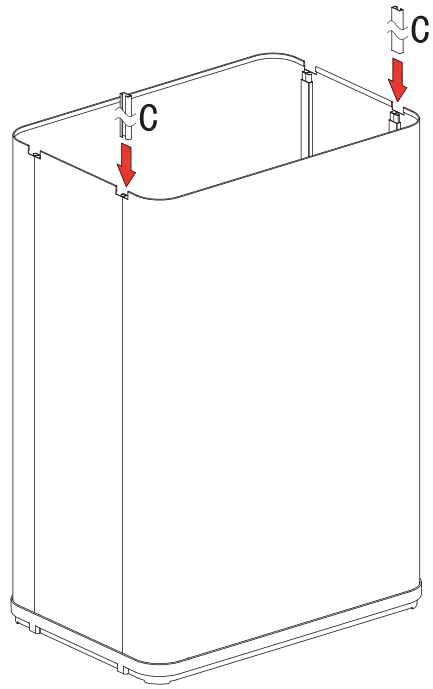

09

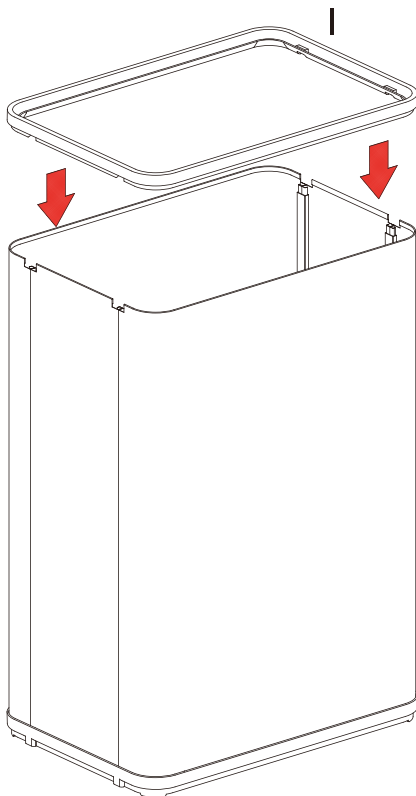

10

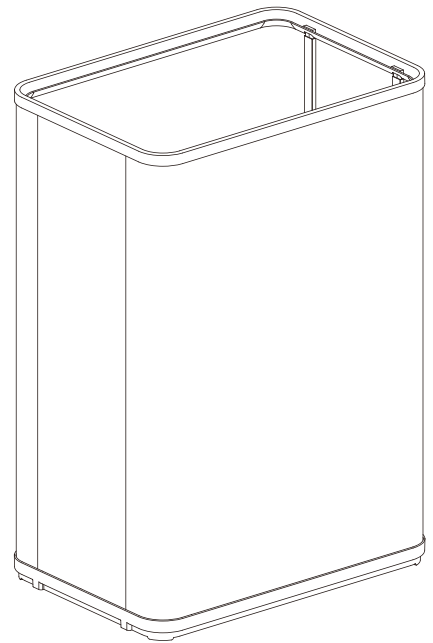

11

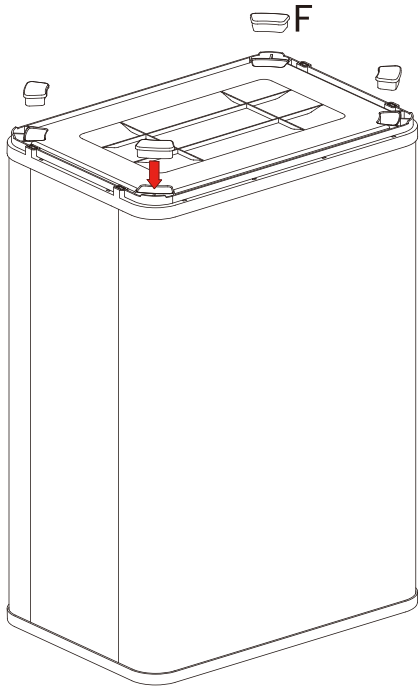

12

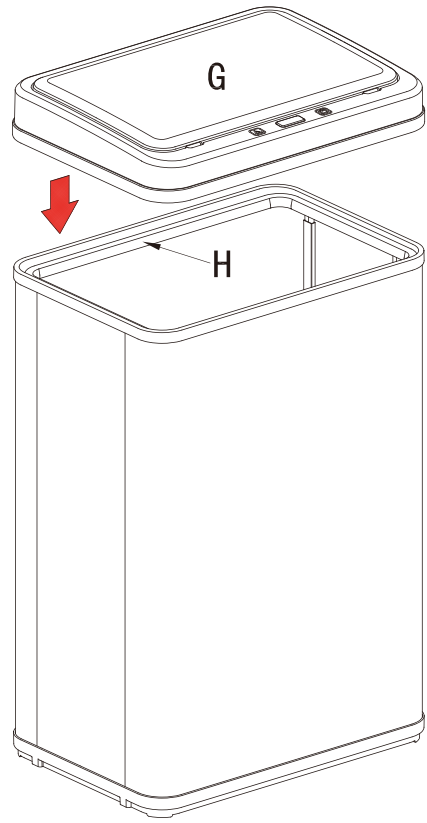

Done

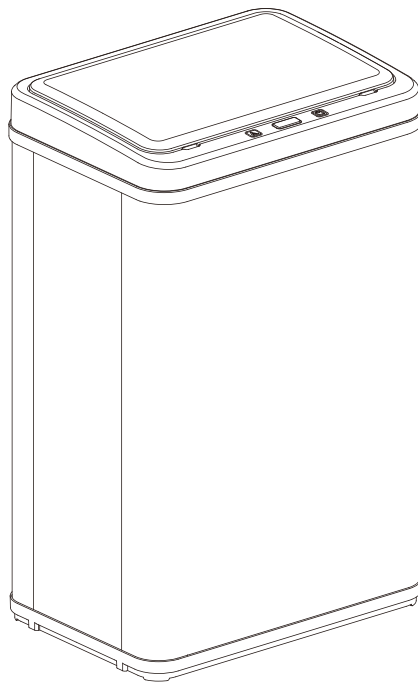

If you have any questions, please contact our customer care center, Our contact details are below: **US**

 001-877-644-9366

 customerservice@aosom.com

Imported by Aosom LLC
27150 SW Kinsman Rd Wilsonville, OR 97070 USA
MADE IN CHINA

If you have any questions, please contact our customer care center, Our contact details are below: **CA**

 416-792-6088

 customerservice@aosom.ca

Imported by Aosom Canada Inc.
7270 Woodbine Avenue, Unit 307, Markham,
Ontario Canada L3R 4B9
MADE IN CHINA

Si vous avez la moindre question, veuillez contacter notre centre d'assistance à la clientèle, Nos coordonnées sont les suivantes:

 416-792-6088

 customerservice@aosom.ca

Importé par Aosom Canada Inc.
7270 Woodbine Avenue, unité 307,
Markham, Ontario Canada L3R 4B9
FABRIQUÉ EN CHINE

If you have any questions, please contact our customer care center, Our contact details are below: **UK**

 0044-800-240-4004

 enquiries@mhstar.co.uk

IMPORTER ADDRESS:
MH STAR UK Ltd
1 Northampton Cross Logistics Park
Northampton Cross Road
Northampton
NN4 9FH
MADE IN CHINA

Si vous avez la moindre question, veuillez contacter notre centre d'assistance à la clientèle, Nos coordonnées sont les suivantes: **FR**

 0033-1-84166106

 aosom@mhfrance.fr

Importé par/Fabricant/REP:
MH FRANCE
2 Rue Maurice Hartmann
92130 Issy Les Moulineaux
France
FABRIQUÉ EN CHINE



FR

Cet appareil, ses accessoires, cordons et batteries se recyclent

REPRISE À LA LIVRAISON



À DÉPOSER EN MAGASIN



À DÉPOSER EN DÉCHÈTERIE



Points de collecte sur www.quefairedemesdechets.fr
Privilégiez la réparation ou le don de votre appareil !

In caso di dubbio, si prega di contattare il nostro centro assistenza clienti, I nostri dettagli di contatto sono di seguito: **IT**

 0039-0249471447

 clienti@aosom.it

IMPORTATO DA/Produttore/REP:
AOSOM Italy srl
Centro Direzionale Milanofiori
Strada 1 Palazzo F1
20057 Assago (MI)
P.I.: 08567220960
FATTO IN CINA

Si tiene alguna pregunta, comuníquese con nuestro Centro de Atención al Cliente, Nuestros datos de contacto son los siguientes: **ES**

 0034-931294512

 atencioncliente@aosom.es

IMPORTADOR/Fabricante/REP:
SPANISH AOSOM, S.L.
C/ROC GROS, N°15.08550, ELS HOSTALET DE BALENYÀ, SPAIN.
B66295775
HECHO EN CHINA

Se tiver alguma dúvida, por favor contacte o nosso Centro de Atendimento ao Cliente, Os nossos dados de contacto são os seguintes:

 0034-931294512

 info@aosom.pt.

IMPORTADOR/Fabricante/REP:
SPANISH AOSOM, S.L.
C.ROC GROS N.15, 08550. ELS HOSTALET DE BALENYÀ
FEITO NA CHINA

Wenn Sie Fragen haben, wenden Sie sich bitte an unser Kundendienstzentrum, Unsere Kontaktdaten stehen unten: **DE**

 0049-0(40)-87408465

 service@aosom.de

ADRESSE DES IMPORTEURE/Hersteller/REP:
MH Handel GmbH
Wendenstraße 309
D-20537 Hamburg
Germany
IN CHINA HERGESTELLT

