

AIYAPLAY

IN250600421V01_UK_FR_DE_ES_IT

370-436V00

Activity Ride-On

EN



WARNING

**ADULT ASSEMBLY
REQUIRED.**



Land Rover and the Land Rover Logo are the trademarks owned and licensed by Jaguar Land Rover Limited.

IMPORTANT, RETAIN FOR FUTURE REFERENCE: READ CAREFULLY

INSTRUCTION MANUAL









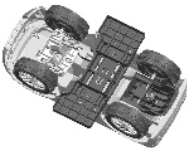

Warning

1. This ride-on is for ages 12-36 months. The maximum weight capacity is 25kg.
2. This product can fit one child at a time.
3. Adult supervision is advised, ensuring children ride safely.
4. Adult assembly is required.
5. Batteries to be handled by adults only.
6. When riding, avoid going near streets, crossroads, traffic areas, swimming pools and stairs.
7. Regularly check the product for any damaged parts.
8. Occasionally check the nut and bolt on the steering wheel, ensuring it is tight and secure.
9. Ensure this product is properly assembled before using.
10. Wear shoes when riding this product.

Battery handling:

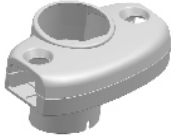
1. Battery must be handled by adults only.
2. Always remove dead batteries.
3. Only use AA batteries.
4. Alkaline batteries are recommended.
5. When the product is not being used for a while, remove the batteries.
6. When changing batteries, ensure they are all changed with new ones.
7. Do not mix old and new batteries.
8. Do not mix alkaline, standard (carbon-zinc) or rechargeable (nickel-cadmium) batteries.
9. Do not throw batteries into a fire – they could explode or leak.
10. Do not charge non-rechargeable batteries.
11. Before charging, remove chargeable batteries from the product.
12. Adult supervision is required when charging batteries.
13. Insert batteries with the correct polarity.
14. Ensure supply terminals are not short-circuited

COMPONENTS LIST

<p>1.Body 1pc</p> 	<p>2.Steering wheel 1pc</p> 	<p>3.Backrest 1pc</p> 
<p>4.Safety bar 1 pair</p> 	<p>5.Thumb latch 2pcs</p> 	<p>6.Push bar 1pc</p> 
<p>7.Connect tube 1pc</p> 	<p>8.Safety bar fixed part 1pc</p> 	<p>9.J-shaped stick 1pc</p> 
<p>10.Nut 3pcs (one replacement pieces)</p> 	<p>11.Bolt 3pcs (one replacement pieces)</p> 	

BATTERY CHANGE



Loosen the screw with a screwdriver, Put AA size batteries in the battery house. Then tight the screw with a screwdriver.

ASSEMBLY

Step 1

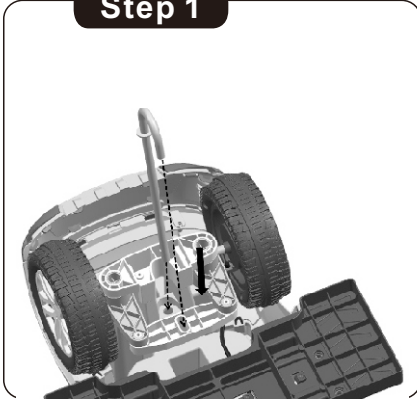

1. Insert the J-shaped stick at the assigned location as picture.

Step 2



2. Loosen the bolt and nut in the steering wheel by a screwdriver (not included).

Step 3



3. Hold the J-shaped stick at the bottom, then place the safety-bar fix part and the steering wheel over the J-shaped stick, insert the bolt and tighten the nut with a screwdriver(not included).

Step 4



4. Insert the backrest into the rear of the body, be certain the backrest is completely seated.

Step 5

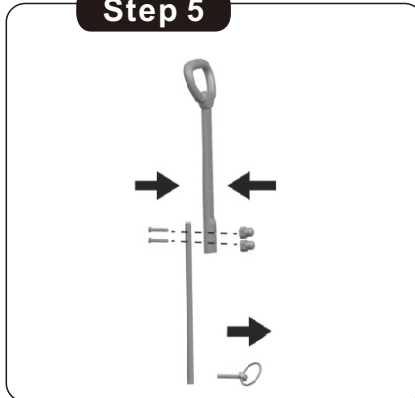

5. Connect the push bar and connect tube with two bolts and nuts as a whole push bar, then take out the snap ring in the end of the tube for standby.

Step 6

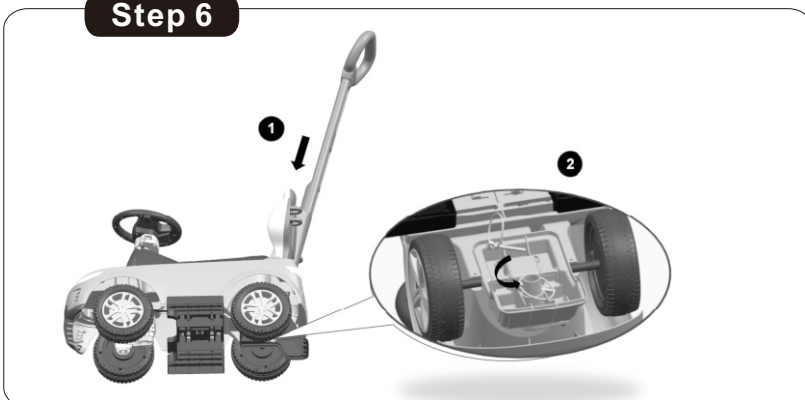

6. Insert the whole push bar into the hole of the backrest, then turn the body over, insert the snap ring and tight as picture show.

Step 7

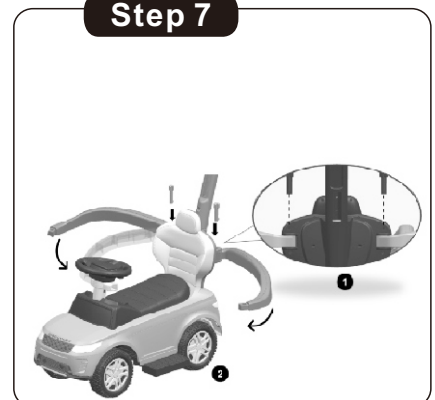

7. Assemble the safety bar into the backrest by the thumb latch, then insert the safety bar into the hole of safety bar fixed part.

AIYAPLAY

IN250600421V01_UK_FR_DE_ES_IT

370-436V00

Activité Véhicule à pédales

FR



ATTENTION

**ASSEMBLAGE PAR UN
ADULTE REQUIS**



Land Rover et le logo Land Rover sont des marques déposées appartenant à Jaguar Land Rover Limited et sous licence.

IMPORTANT : A LIRE ATTENTIVEMENT ET À CONSERVER POUR CONSULTATION ULTÉRIEURE.

MANUEL D'INSTRUCTIONS

ATTENTION

1. Cette voiture autoportée est destinée aux enfants de 12 à 36 mois. Sa capacité de charge maximale est de 25 kg.
2. Ce produit ne peut accueillir qu'un seul enfant à la fois.
3. La surveillance d'un adulte est conseillée afin de garantir la sécurité des enfants.
4. L'assemblage par un adulte est nécessaire.
5. Les piles doivent être manipulées par des adultes uniquement.
6. Lorsque vous roulez, évitez de conduire à proximité des rues, des carrefours, des zones de circulation, des piscines et des escaliers.
7. Vérifiez régulièrement que le produit ne présente pas de pièces endommagées.
8. Vérifiez de temps en temps l'écrou et le boulon du volant, en vous assurant qu'ils sont bien serrés et sécurisés.
9. Assurez-vous que ce produit est correctement assemblé avant de l'utiliser.
10. Portez des chaussures lorsque vous conduisez ce produit.

Manipulation de la pile:

1. La pile doit être manipulée par des adultes uniquement.
2. Retirez toujours les piles mortes.
3. N'utilisez que des piles AA.
4. Il est recommandé d'utiliser des piles alcalines.
5. Retirez les piles lorsque le produit n'est pas utilisé pendant un certain temps.
6. Lorsque vous changez les piles, assurez-vous qu'elles sont toutes remplacées par des piles neuves.
7. Ne mélangez pas les anciennes et les nouvelles piles.
8. Ne mélangez pas des piles alcalines, standard (carbone-zinc) ou rechargeables (nickel-cadmium).
9. Ne jetez pas de piles dans un feu - elles pourraient provoquer une explosion ou suinter dans le sol.
10. Ne chargez pas les piles non rechargeables.
11. Avant de charger les piles, retirez-les du produit.
12. La surveillance d'un adulte est requise lors du chargement des piles.
13. Insérez les piles en respectant la polarité.
14. Veillez à ce que les bornes d'alimentation ne soient pas court-circuitées.



FR

Cet appareil,
ses accessoires,
cordons et batteries
se recyclent

REPRISE
À LA LIVRAISON



OU

À DÉPOSER
EN MAGASIN











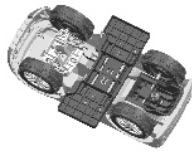

OU

À DÉPOSER
EN DÉCHÈTERIE



Points de collecte sur www.quefairedemesdechets.fr
Privilégiez la réparation ou le don de votre appareil !

LISTE DES PIÈCES

1. Corps 1 pièce 	2. Volant 1 pc 	3. Dossier 1 pc 
4. Barre de sécurité 1 paire 	5. Loquet à pouce 2 pcs 	6. Barre de poussée 1 pc 
7. Tube de connexion 1 pc 	8. Partie fixe de la barre de sécurité 1 pc 	9. Bâton en forme de J 1 pc 
10. Écrou 3 pcs (une pièce de rechange) 	11. Boulon 3 pcs (une pièce de rechange) 	

CHANGEMENT DE PILE



Desserrez la vis avec un tournevis, insérez des piles de taille AA dans le compartiment à piles.

Puis serrez la vis avec un tournevis.

ASSEMBLAGE

Étape 1

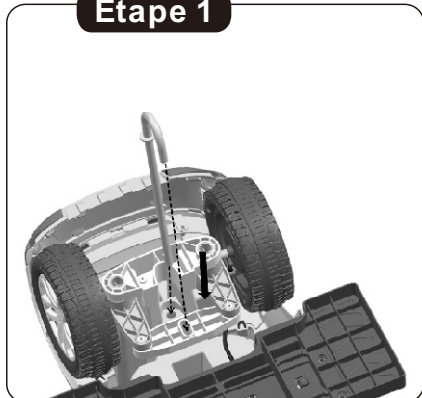

1. Insérez la tige en forme de J à l'emplacement indiqué sur l'image.

Étape 2



2. Desserrez le boulon et l'écrou du volant à l'aide d'un tournevis (non inclus).

Étape 3



3. Tenez la tige en forme de J par le bas, puis placez la pièce de fixation de la barre de sécurité et le volant sur la tige en forme de J, insérez le boulon et serrez l'écrou avec un tournevis (non inclus).

Étape 4

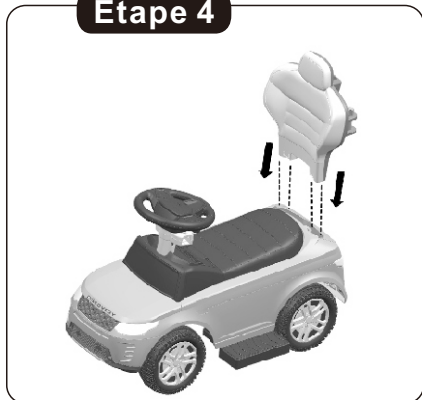

4. Insérez le dossier à l'arrière du corps, en vous assurant que le dossier est complètement en place.

Étape 5

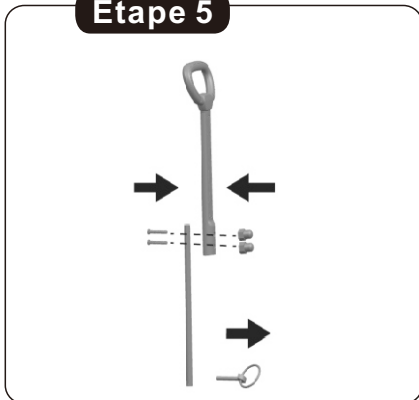

5. Connectez la barre de poussée et le tube de connexion avec deux boulons et écrous pour former une barre de poussée complète, puis retirez l'anneau de retenue à l'extrémité du tube pour le mettre de côté.

Étape 6

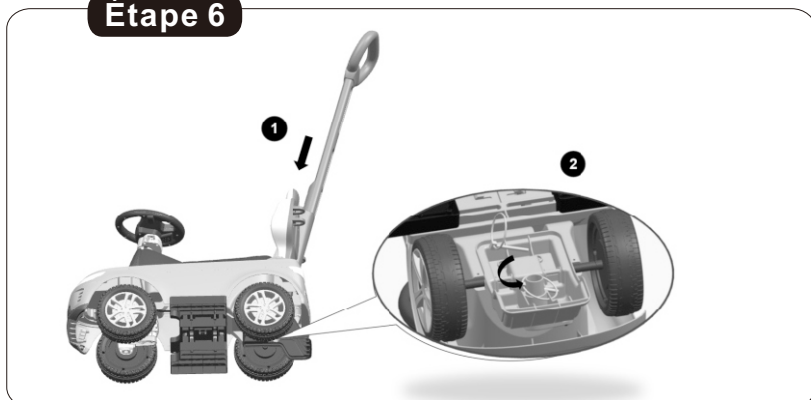

6. Insérez la barre de poussée complète dans le trou du dossier, puis retournez le corps, insérez l'anneau de retenue et serrez comme indiqué sur la photo.

Étape 7

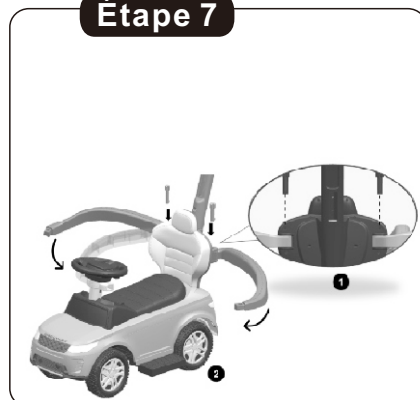

7. Assemblez la barre de sécurité au dossier à l'aide du loquet à pouce, puis insérez la barre de sécurité dans le trou de la partie fixe de la barre de sécurité.

AIYAPLAY

IN250600421V01_UK_FR_DE_ES_IT

370-436V00

Aktivitätsfahrzeug

DE



 **ACHTUNG**

Montage durch einen
Erwachsenen
erforderlich



CE

Land Rover und das Land Rover Logo sind Marken, die im Besitz von Jaguar Land Rover Limited sind und von dieser lizenziert werden.

WICHTIG! SORGFÄLTIG LESEN UND FÜR SPÄTER NACHSCHLAGEN AUFBEWAHREN.

BEDIENUNGSANLEITUNG

ACHTUNG

1. Dieses Aufsitzauto ist für Kinder zwischen 12 und 36 Monaten geeignet. Die maximale Gewichtskapazität beträgt 25 kg.
2. Dieses Produkt ist für jeweils ein Kind geeignet.
3. Die Aufsicht durch einen Erwachsenen wird empfohlen, damit die Kinder sicher fahren.
4. Die Montage durch einen Erwachsenen ist erforderlich.
5. Die Batterien dürfen nur von Erwachsenen gehandhabt werden.
6. Vermeiden Sie beim Fahren die Nähe von Straßen, Kreuzungen, Verkehrsflächen, Schwimmbädern und Treppen.
7. Überprüfen Sie das Produkt regelmäßig auf beschädigte Teile.
8. Überprüfen Sie gelegentlich die Schrauben und Muttern am Lenkrad und stellen Sie sicher, dass sie fest angezogen und sicher sind.
9. Stellen Sie vor der Verwendung sicher, dass das Produkt richtig zusammengebaut ist.
10. Tragen Sie beim Fahren mit diesem Produkt Schuhe.

Handhabung der Batterie:

1. Die Batterie darf nur von Erwachsenen gehandhabt werden.
2. Entfernen Sie immer leere Batterien.
3. Verwenden Sie nur AA-Batterien.
4. Es werden Alkalibatterien empfohlen.
5. Entfernen Sie die Batterien, wenn das Produkt eine Zeit lang nicht benutzt wird.
6. Achten Sie beim Auswechseln der Batterien darauf, dass alle durch neue ersetzt werden.
7. Vermischen Sie alte und neue Batterien nicht.
8. Mischen Sie keine Alkali-, Standard- (Kohle-Zink) oder wiederaufladbare (Nickel-Cadmium) Batterien.
9. Werfen Sie Batterien nicht ins Feuer – sie könnten explodieren oder auslaufen.
10. Laden Sie keine nicht wiederaufladbaren Batterien auf.
11. Nehmen Sie aufladbare Batterien vor dem Aufladen aus dem Produkt.
12. Das Laden von Batterien muss unter Aufsicht von Erwachsenen erfolgen.
13. Setzen Sie die Batterien mit der richtigen Polarität ein.
14. Stellen Sie sicher, dass die Versorgungsklemmen nicht kurzgeschlossen sind.

KOMPONENTENLISTE

<p>1. Karosserie 1 Stück</p> 	<p>2. Lenkrad 1 Stück</p> 	<p>3. Rückenlehne 1 Stück</p> 
<p>4. Sicherheitsbügel 1 Paar</p> 	<p>5. Daumenriegel 2 Stück</p> 	<p>6. Schiebebügel 1 Stück</p> 
<p>7. Schlauch anschließen 1 Stk.</p> 	<p>8. Befestigungsteil der Sicherheitsstange 1 Stk.</p> 	<p>9. J-förmiger Stab 1 Stk.</p> 
<p>10. Mutter 3 Stk. (ein Ersatzteil)</p> 	<p>11. Bolzen 3 Stück (ein Ersatzteil)</p> 	

BATTERIEWECHSEL



Lösen Sie die Schraube mit einem Schraubendreher, legen Sie AA-Batterien in das Batteriefach ein.

Dann ziehen Sie die Schraube mit einem Schraubendreher fest.

MONTAGE

Schritt 1

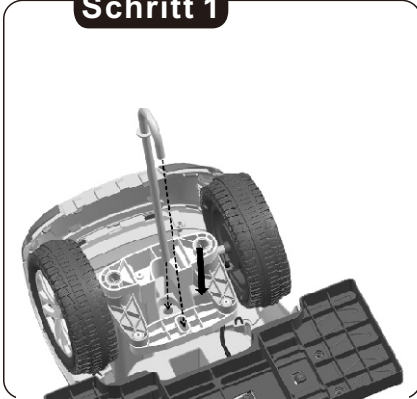

1. Setzen Sie den J-förmigen Stab an der vorgesehenen Stelle wie auf dem Bild ein.

Schritt 2



2. Lösen Sie die Schraube und Mutter am Lenkrad mit einem Schraubendreher (nicht enthalten).

Schritt 3

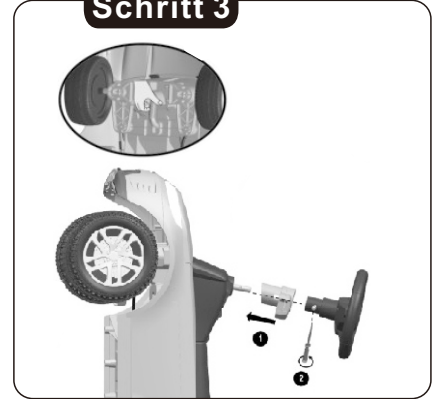

3. Halten Sie den J-förmigen Stab am unteren Ende, dann setzen Sie den Sicherheitsbügel und das Lenkrad über den J-förmigen Stab, stecken Sie die Schraube ein und ziehen Sie die Mutter mit einem Schraubendreher (nicht enthalten) fest.

Schritt 4



4. Setzen Sie die Rückenlehne in den hinteren Teil des Körpers ein und stellen Sie sicher, dass die Rückenlehne vollständig sitzt.

Schritt 5

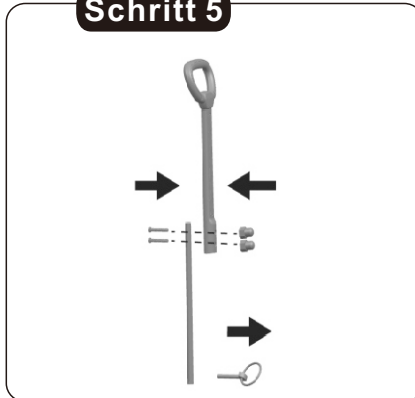

5. Verbinden Sie die Schubstange und das Verbindungsrohr mit zwei Schrauben und Muttern zu einer kompletten Schubstange, nehmen Sie dann den Sicherungsring am Ende des Rohrs heraus und legen Sie ihn beiseite.

Schritt 6

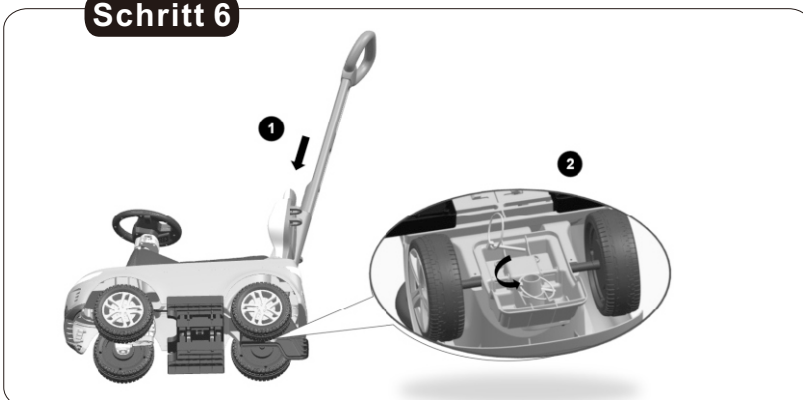

6. Stecken Sie die gesamte Schubstange in das Loch der Rückenlehne, drehen Sie dann den Körper um, setzen Sie den Sicherungsring ein und ziehen Sie ihn fest, wie auf dem Bild gezeigt.

Schritt 7

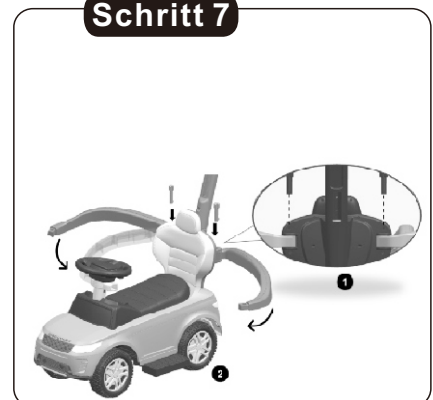

7. Montieren Sie die Sicherheitsstange an der Rückenlehne mit dem Daumenverschluss, stecken Sie dann die Sicherheitsstange in das Loch des Befestigungsteils der Sicherheitsstange.

AIYAPLAY

IN250600421V01_UK_FR_DE_ES_IT

370-436V00

Actividad para montar

ES



 **ADVERTENCIA**
EL MONTAJE DEBE
SER REALIZADO POR
ADULTOS



Land Rover y el logotipo de Land Rover son marcas comerciales propiedad y licenciadas por Jaguar Land Rover Limited.

IMPORTANTE, LEA DETENIDAMENTE Y GUARDE PARA FUTURAS REFERENCIAS.

MANUAL DE INSTRUCCIONES

Advertencia

1. Este Ride-on automóvil es apto para los niños de 12 a 36 meses. La capacidad de carga máxima de peso es de 25 kg.
2. Este automóvil puede acomodar a un/a niño/a a la vez.
3. Se recomienda la supervisión de un adulto responsable para garantizar que los niños viajen seguramente.
4. El montaje debe ser realizado por los adultos.
5. Las baterías solo deben ser manipuladas por los adultos.
6. Al conducir este automóvil, evite acercarse a las calles, las intersecciones, los áreas de tráfico, las piscinas y las escaleras.
7. Inspeccione el automóvil con regularidad en busca de cualquier pieza dañada.
8. Inspeccione la tuerca y el perno en el volante de vez en cuando para asegurarse de que estén apretados firmemente y seguros.
9. Asegúrese de que este automóvil esté montado de manera correcta antes de utilizarlo.
10. Use zapatos cuando utilice este automóvil.

Manejar las baterías:

1. Las baterías solo deben ser manipuladas por los adultos.
2. Siempre retire las baterías agotadas.
3. Solo utilice las baterías AA.
4. Se recomiendan utilizar las baterías alcalinas.
5. Cuando no utilice el automóvil durante largo plazo, retire las baterías.
6. Al reemplazar las baterías, asegúrese de reemplazar todas las baterías usadas por otras nuevas.
7. No mezcle las baterías viejas y nuevas.
8. No mezcle las baterías alcalinas, estándar (carbono-zinc) o recargables (níquel-cadmio).
9. No deseche las baterías al fuego, de lo contrario, las baterías podrían explotar o tener fugas.
10. No cargue las baterías no recargables.
11. Antes de cargar las baterías recargables, retírelas del automóvil.
12. Al cargar las baterías, se requiere la supervisión de un adulto responsable.
13. Inserte las baterías con los electrodos correctamente conectados.
14. Asegúrese de que los terminales de alimentación no estén en cortocircuito.

LISTA DE COMPONENTES

<p>1. Cuerpo 1 pieza</p> 	<p>2. Volante 1 pieza</p> 	<p>3. Respaldo 1 pieza</p> 
<p>4. Barra de seguridad 1 par</p> 	<p>5. Pestillo de pulgar 2 piezas</p> 	<p>6. Barra de empuje 1 pieza</p> 
<p>7. Conectar tubo 1 pieza</p> 	<p>8. Parte fija de barra de seguridad 1 pieza</p> 	<p>9. Palo en forma de J 1 pieza</p> 
<p>10. Tuerca 3 piezas (una pieza de repuesto)</p> 	<p>11. Tornillo 3 piezas (una pieza de repuesto)</p> 	

CAMBIO DE BATERÍA



Afloje el tornillo con un destornillador. Coloque pilas tamaño AA en el compartimento de baterías.

Luego apriete el tornillo con un destornillador.

MONTAJE

Paso 1



1. Inserte el palo en forma de J en el lugar asignado según la imagen.

Paso 2



2. Afloje el perno y la tuerca en el volante con un destornillador (no incluido).

Paso 3



3. Sostenga el palo en forma de J por la parte inferior, luego coloque la pieza de fijación de la barra de seguridad y el volante sobre el palo en forma de J, inserte el perno y apriete la tuerca con un destornillador (no incluido).

Paso 4



4. Inserte el respaldo en la parte trasera del cuerpo, asegurándose de que el respaldo esté completamente asentado.

Paso 5

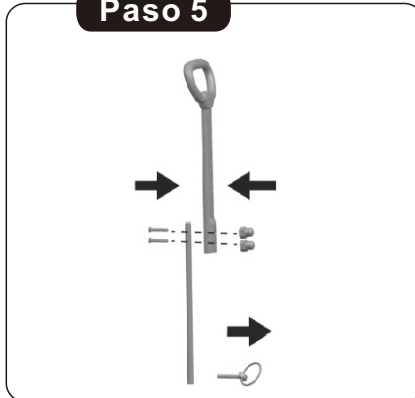

5. Conecte la barra de empuje y el tubo de conexión con dos pernos y tuercas como una barra de empuje completa, luego saque el anillo de seguridad en el extremo del tubo para tenerlo a mano.

Paso 6

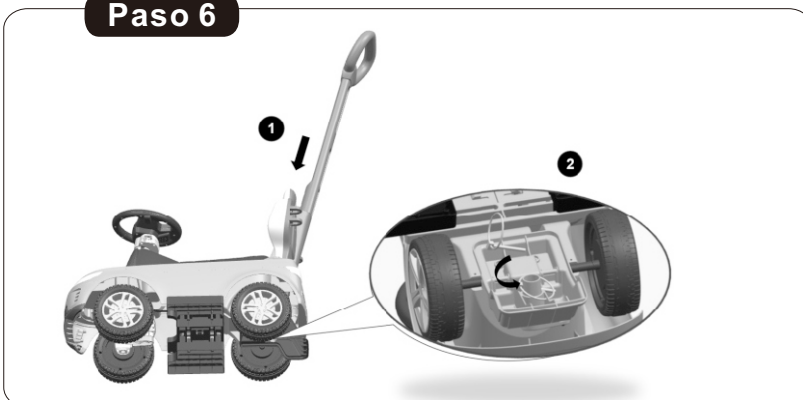

6. Inserte toda la barra de empuje en el agujero del respaldo, luego voltee el cuerpo, inserte el anillo de seguridad y apriete como muestra la imagen.

Paso 7



7. Ensamble la barra de seguridad en el respaldo mediante el pestillo de pulgar, luego inserte la barra de seguridad en el agujero de la parte fija de la barra de seguridad.

AIYAPLAY

IN250600421V01_UK_FR_DE_ES_IT

370-436V00

Attività Cavalcabile

IT



 **AVVERTENZA**
NECESSARIO IL
MONTAGGIO DA
PARTE DI UN ADULTO



Land Rover e il logo Land Rover sono marchi di proprietà e concessi in licenza da Jaguar Land Rover Limited.

IMPORTANTE, LEGGERE E CONSERVARE QUESTO MANUALE D'ISTRUZIONE PER UN USO FUTURO.

MANUALE DI ISTRUZIONI

Avvertenze

1. Questa macchina giocattolo è progettata per bambini di età compresa tra 12 e 36 mesi. La portata massima è di 25 kg.
2. Questo prodotto è adatto ad essere usato da un bambino alla volta.
3. Si consiglia la supervisione di un adulto, assicurandosi che i bambini guidino in sicurezza.
4. È richiesto il montaggio da parte di un adulto.
5. Le batterie devono essere maneggiate solo da adulti.
6. Durante la guida, evitare di avvicinarsi a strade, incroci, zone trafficate, piscine e scale.
7. Controllare regolarmente il prodotto per rilevare eventuali parti danneggiate.
8. Controllare regolarmente il dado e il bullone sul volante, assicurandosi che siano ben stretti in sicurezza.
9. Assicurarsi che questo prodotto sia assemblato correttamente prima dell'uso.
10. Indossare scarpe quando si guida questo prodotto.

Gestione delle batterie:

1. Le batterie devono essere maneggiate solo da adulti.
2. Rimuovere sempre le batterie scariche.
3. Utilizzare solo batterie AA.
4. Si consiglia l'uso di batterie alcaline.
5. Quando il prodotto non viene utilizzato a lungo, rimuovere le batterie.
6. Quando si sostituiscono le batterie, assicurarsi che siano tutte sostituite con batterie nuove.
7. Non mischiare batterie vecchie e nuove.
8. Non mischiare batterie alcaline, standard (carbone-zinco) o ricaricabili (nichel-cadmio).
9. Non smaltire le batterie nel fuoco: potrebbero esplodere o potrebbero esserci perdite.
10. Non tentare di ricaricare batterie non ricaricabili.
11. Prima della ricarica, rimuovere le batterie ricaricabili dal prodotto.
12. È necessaria la supervisione di un adulto durante la ricarica delle batterie.
13. Inserire le batterie secondo la polarità corretta.
14. Assicurarsi che i terminali di alimentazione non siano in stato di cortocircuito.

LISTA COMPONENTI

<p>1. Corpo 1 pz</p> 	<p>2. Volante 1 pz</p> 	<p>3. Schienale 1 pz</p> 
<p>4. Barra di sicurezza 1 paio</p> 	<p>5. Fermo a pollice 2 pz</p> 	<p>6. Barra di spinta 1 pz</p> 
<p>7. Collegare il tubo 1 pz</p> 	<p>8. Parte fissa della barra di sicurezza 1 pz</p> 	<p>9. Bastone a forma di J 1 pz</p> 
<p>10. Dado 3 pz (pezzi di ricambio uno)</p> 	<p>11. Bullone 3 pezzi (pezzi di ricambio uno)</p> 	

CAMBIO BATTERIA



Allentare la vite con un cacciavite, inserire le batterie di tipo AA nel vano batterie. Quindi stringere la vite con un cacciavite.

ASSEMBLAGGIO

Passo 1

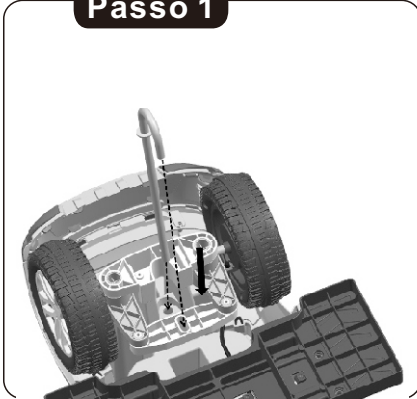

1. Inserire il bastone a forma di J nella posizione assegnata come mostrato nell'immagine.

Passo 2



2. Allentare il bullone e il dado nel volante con un cacciavite (non incluso).

Passo 3



3. Tenere il bastone a forma di J dalla parte inferiore, quindi posizionare la parte di fissaggio della barra di sicurezza e il volante sul bastone a forma di J, inserire il bullone e stringere il dado con un cacciavite (non incluso).

Passo 4



4. Inserire lo schienale nella parte posteriore del corpo, assicurandosi che lo schienale sia completamente inserito.

Passo 5

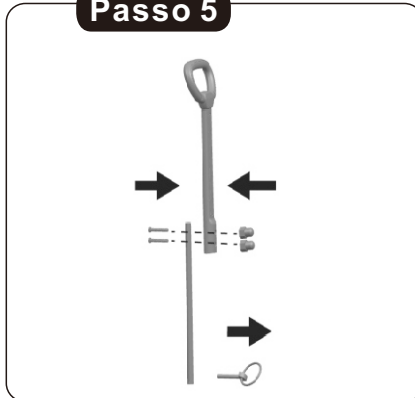

5. Collegare la barra di spinta e il tubo di collegamento con due bulloni e dadi come un'unica barra di spinta, quindi rimuovere la clip di sicurezza all'estremità del tubo per tenerla a portata di mano.

Passo 6

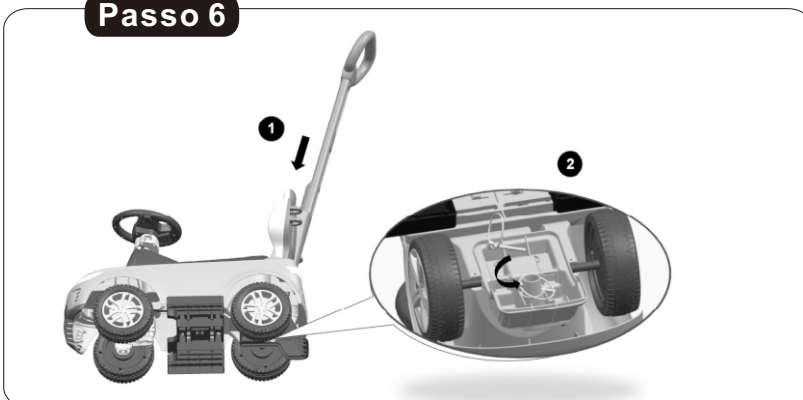

6. Inserire l'intera barra di spinta nel foro dello schienale, quindi girare il corpo, inserire la rondella di sicurezza e stringere come mostrato nell'immagine.

Passo 7

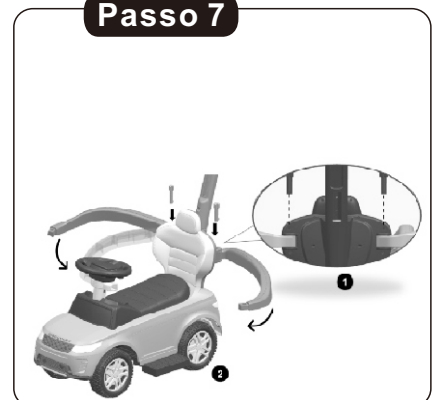

7. Assemblare la barra di sicurezza nello schienale tramite la chiusura a scatto, quindi inserire la barra di sicurezza nel foro della parte fissa della barra di sicurezza.

UK

If you have any questions, please contact our customer care centre.

Our contact details are below:



0044-800-240-4004



enquiries@mhstar.co.uk

IMPORTER ADDRESS:

MH STAR UK LTD

Unit 27, Perivale Park,

Horsenden lane South

Perivale, UB6 7RH

MADE IN CHINA

ES

Si tiene alguna pregunta, comuníquese con nuestro Centro de Atención al Cliente.

Nuestros datos de contacto son los siguientes:



0034-931294512



atencioncliente@aosom.es

Importador/Fabricante/REP:

Spanish Aosom, S.L.

C/ Roc Gros, nº 15. 08550, Els Hostalets de

Balenyà, Spain.

B66295775

atencioncliente@aosom.es

TEL: 931294512

HECHO EN CHINA

FR

Si vous avez la moindre question, veuillez contacter notre centre d'assistance à la clientèle.

Nos coordonnées sont les suivantes:



0033-1-84166106



aosom@mhfrance.fr

Importé par/Fabricant/REP:

MH France

2, rue Maurice Hartmann

92130 Issy-les-Moulineaux

France

Fabriqué en Chine

PT

Se tiver alguma dúvida, por favor contacte o nosso Centro de Atendimento ao Cliente.

Os nossos dados de contacto são os seguintes:



0034-931294512



info@aosom.pt.

IMPORTADOR:

SPANISH AOSOM, S.L

C.ROC GROS N.15, 08550. ELS HOSTALETES DE BALENYÀ

TEL: 931294512 (SEG-SEX DAS 7:30H ÀS 16:30H)

INFO@AOSOM.PT

WWW.AOSOM.PT

DE

Wenn Sie Fragen haben, wenden Sie sich bitte an unser Kundendienstzentrum.

Unsere Kontaktdaten stehen unten:



0049-0(40)-87408465



service@aosom.de

Importeur/Hersteller/REP:

MH Handel GmbH

Wendenstraße 309

D-20537 Hamburg

Germany

IN CHINA HERGESTELLT

IT

In caso di dubbio, si prega di contattare il nostro centro assistenza clienti.

I nostri dettagli di contatto sono di seguito:



0039-0249471447



clienti@aosom.it

IMPORTATO DA/Produttore/REP:

AOSOM Italy srl

Centro Direzionale Milanofiori

Strada 1 Palazzo F1

20057 Assago (MI)

P.I.: 08567220960

FATTO IN CINA

