

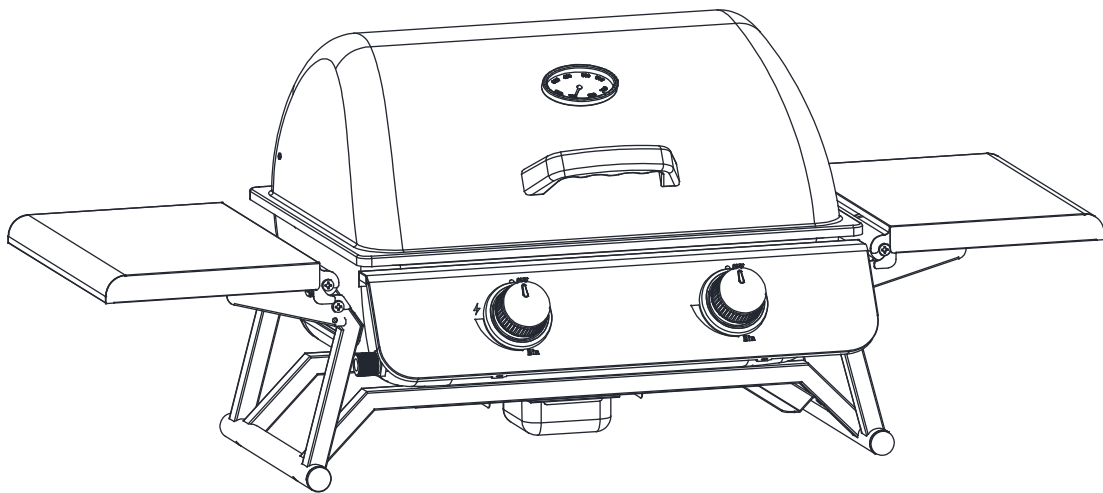

IN240900561V01\_UK

**846-182V70BK**



## **GAS BARBECUE**

If a part needs replacing, please contact our customer service department or your distributor. The use of non-approved parts could present a safety risk when using the barbecue and a risk to the environment.

**IMPORTANT, RETAIN FOR FUTURE REFERENCE: READ CAREFULLY**

# **INSTRUCTION MANUAL**

## Technical specification

Product Name	Gas Barbecue			
Model No.	H18002P			
SKU Code	846-182V70BK			
Heat Rate	5.6 kW			
Destination	UK			
Gas Category	<input checked="" type="checkbox"/> I3+(28-30/37)	I3B/P(30)	I3B/P(50)	
Type of gas	Butane	Propane	Butane/Propane/LPG Gas Mixtures	
Gas Pressure	28-30 mbar	37 mbar	30 mbar	50 mbar
Consumption	408 g/h	400 g/h	408 g/h	408 g/h
Injector Size	0.83 mm		0.72mm	
Country of destination	I3+(28-30/37)	BE,CH,CY,CZ,ES,FR,GB,GR,IE,IT,LT,LU,LV,PT,SK,SI		
	I3B/P(30)	BE,CY,DK,EE,FI,FR,HU,IT,LT,NL,NO,SE,SI,SK,RO,HR TR,BG,IS,LU,MT		
	I3B/P(50)	AT,DE,SK,CH		
Identification Code	0063CR7809		 <b>0063-24</b>	
Outdoor use only.				
ATTENTION : Accessible parts may be very hot. Keep young children away.				
Please read the operating instruction before using the appliance.				

Manufacturer : Foshan City nanhai huangyao Hardware & Electrical Co., Ltd









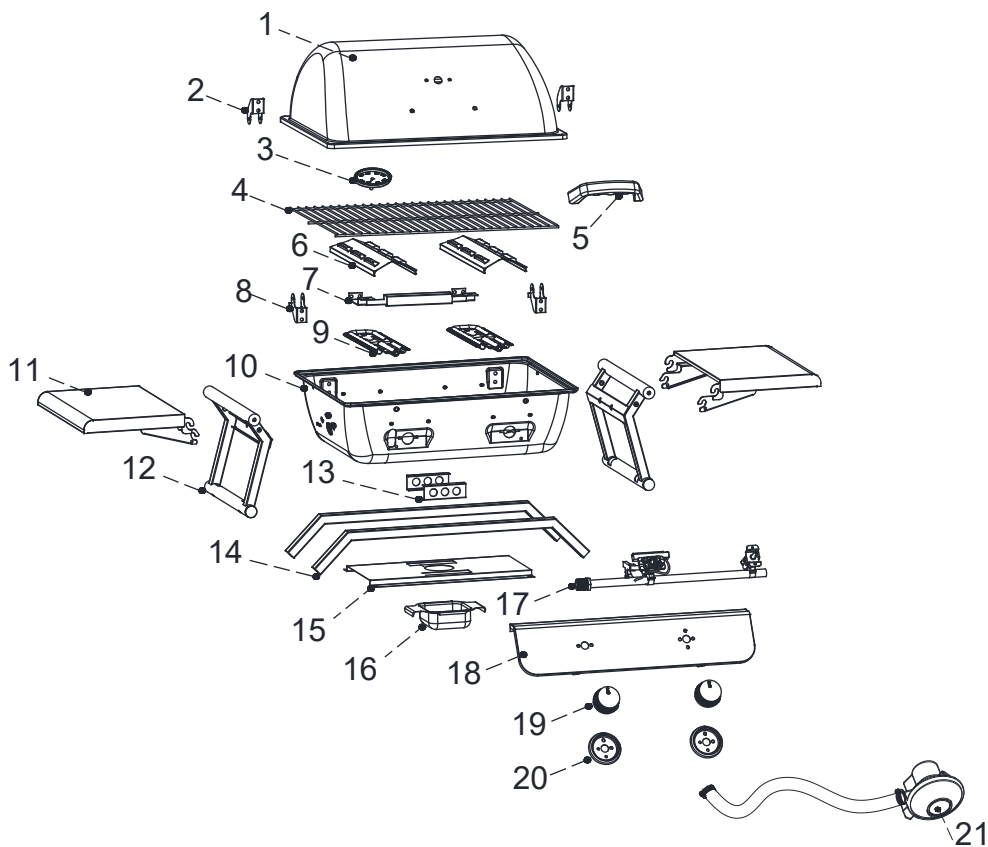

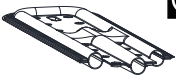

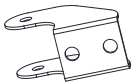
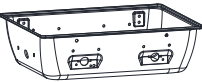
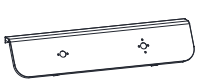











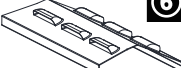

**Lighting** : Main Burner: Single shot piezo ignition unit which lights a transient pilot

**Warning: DO NOT put the grill on  
any combustible surface during use.**

## **IMPORTANT**

- **Read the following instructions carefully and ensure that your barbecue is correctly installed, assembled and maintained. Failure to follow these instructions could cause serious injury and/or damage to property.**
- **Use outdoor only.**
- **WARNING : accessible parts may be very hot . Keep young children away .**
- **Read the instructions before using the appliance.**
- **This appliance must be kept away from flammable materials during use.**
- **Do not move the appliance during use.**
- **Turn off the gas supply at the gas cylinder after use.**
- **Do not modify the appliance.**
- **Always use protective gloves when handling particularly hot components.**
- **For any question concerning the assembly or operation of the appliance, please contact your retailer or LPG distributor.**
- **When choosing a site for use, always position the appliance and gas cylinder on a flat surface.**
- **Never light the appliance with the LID closed.**
- **Your barbecue uses an 11 or 15 kg gas cylinder. Your barbecue's performance will be improved by the use of propane or LPG mixtures. Butane can be used but, due to the appliance's power, the cylinder will tend to seize and produce low pressure gas, which will affect your barbecue's performance.**
- **When choosing a location for your barbecue, the following criteria should be taken into consideration.**
- **Both sides and behind the barbecue: the sides and rear of the barbecue should be 1 metre away from any item likely to impede its operation.**
- **Above the barbecue: THERE SHOULD BE NOTHING ABOVE THE BARBECUE.**
- **NOTE TO THE CONSUMER --- Please keep these instructions for future reference.**



 <b>①</b> x 1	 <b>⑨</b> x 2	 <b>⑰</b> x 1	M6x10  <b>a</b> x 16
 <b>②</b> x 2	 <b>⑩</b> x 1	 <b>⑱</b> x 1	M6x15  <b>b</b> x 6
 <b>③</b> x 1	 <b>⑪</b> x 2	 <b>⑲</b> x 2	M6x15  <b>c</b> x 4
 <b>④</b> x 1	 <b>⑫</b> x 2	 <b>⑳</b> x 2	M6x10  <b>d</b> x 8
 <b>⑤</b> x 1	 <b>⑬</b> x 2	 <b>㉑</b> x 1	M4x10  <b>e</b> x 22
 <b>⑥</b> x 2	 <b>⑭</b> x 2	 <b>⑳</b> x 2	M6  <b>f</b> x 4
 <b>⑦</b> x 1	 <b>⑮</b> x 1		M4  <b>g</b> x 8
 <b>⑧</b> x 2	 <b>⑯</b> x 1		Hinge Axle  <b>h</b> x 2
			Clip  <b>i</b> x 2

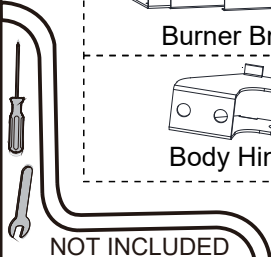

**a x 4**



M6x10

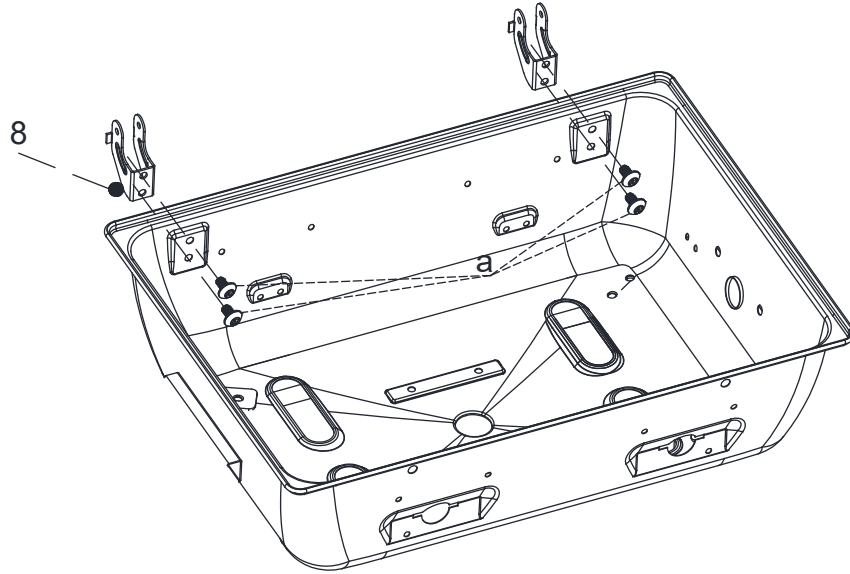

**e x 4**



M4x10

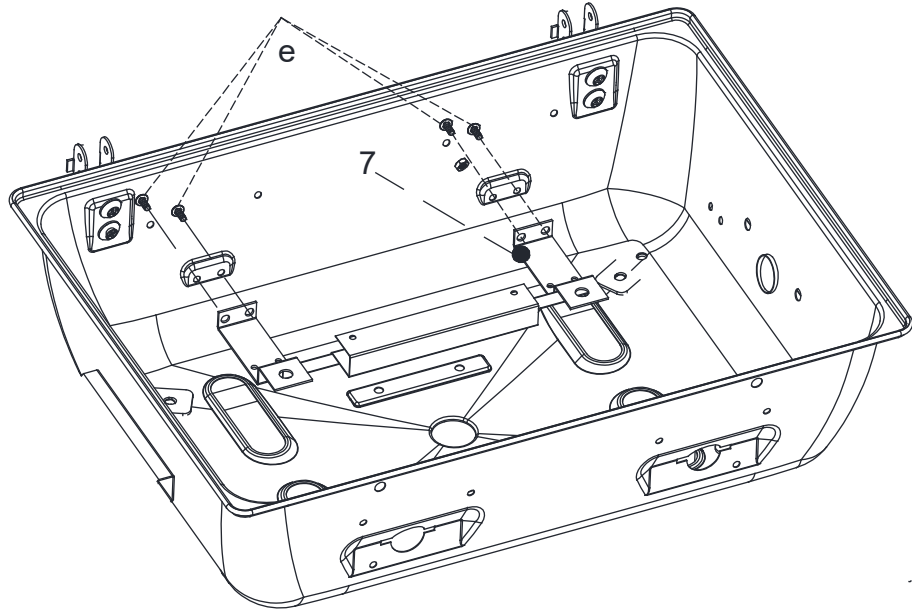

**e x 8**



M4x10

**g x 8**



M4

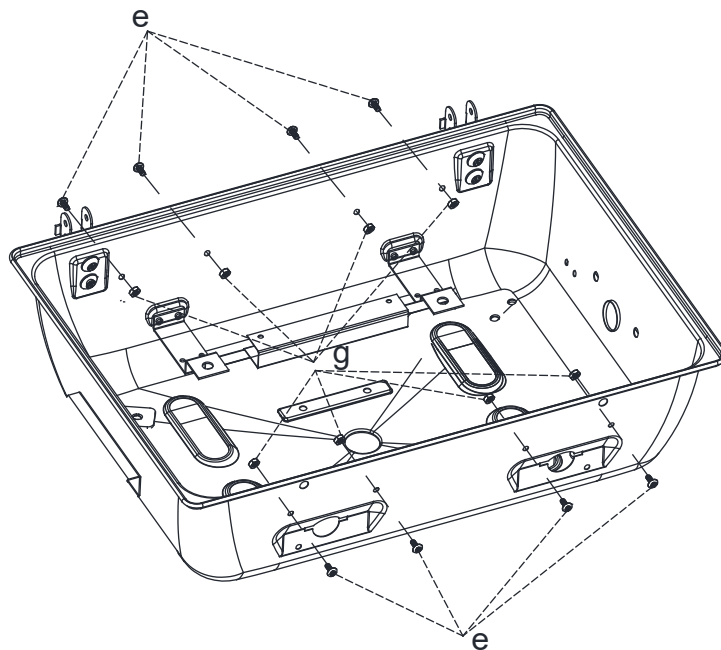

ex 4



M4x10

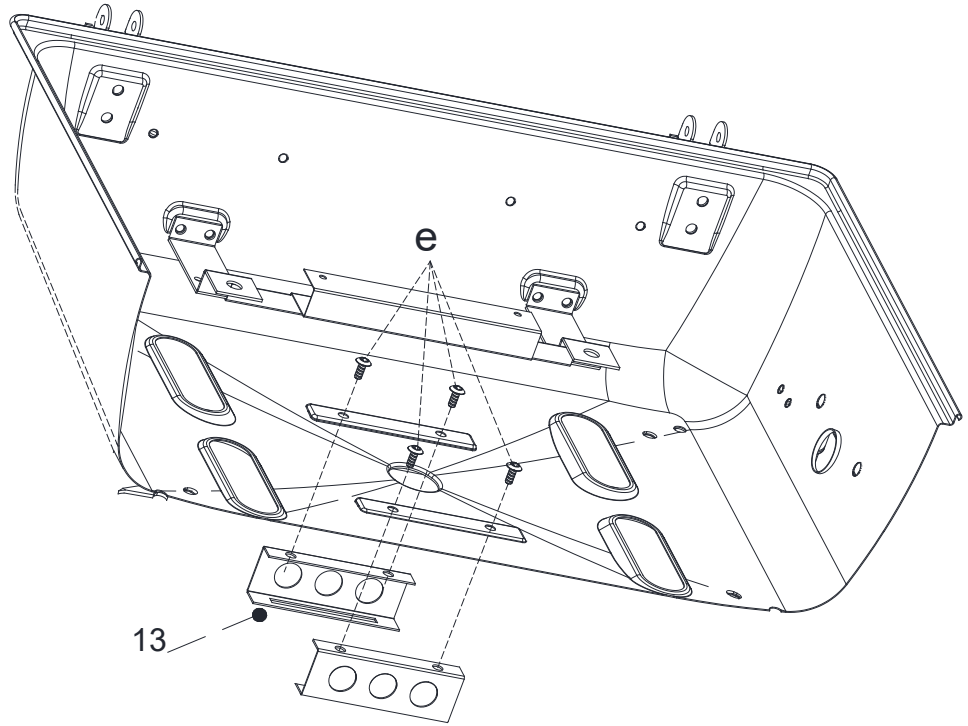

ex 4



M4x10

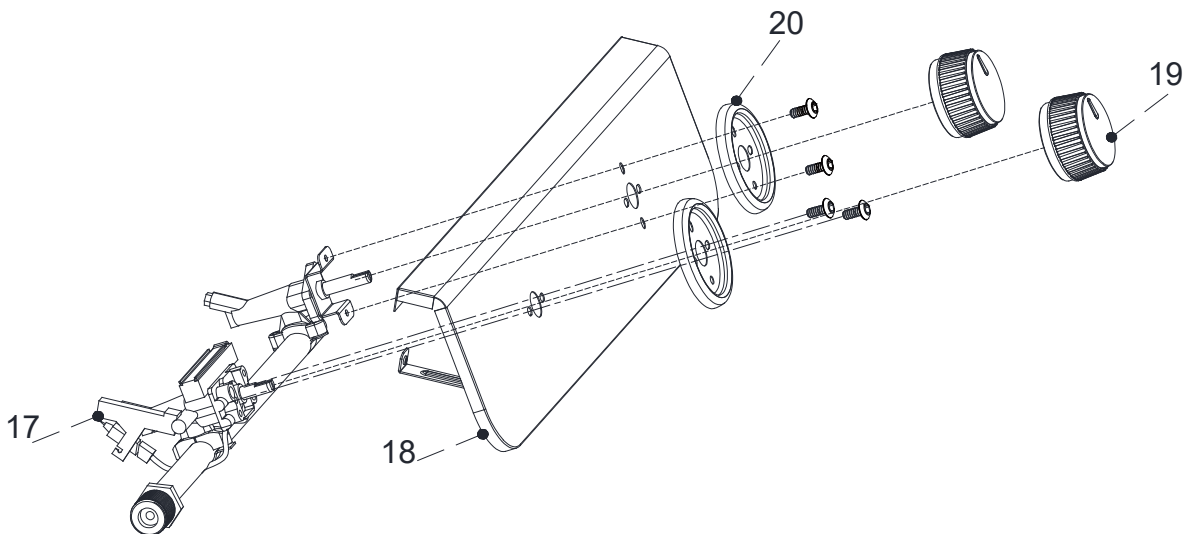

**a x 2**

M6x10

**e x 2**

M4x10

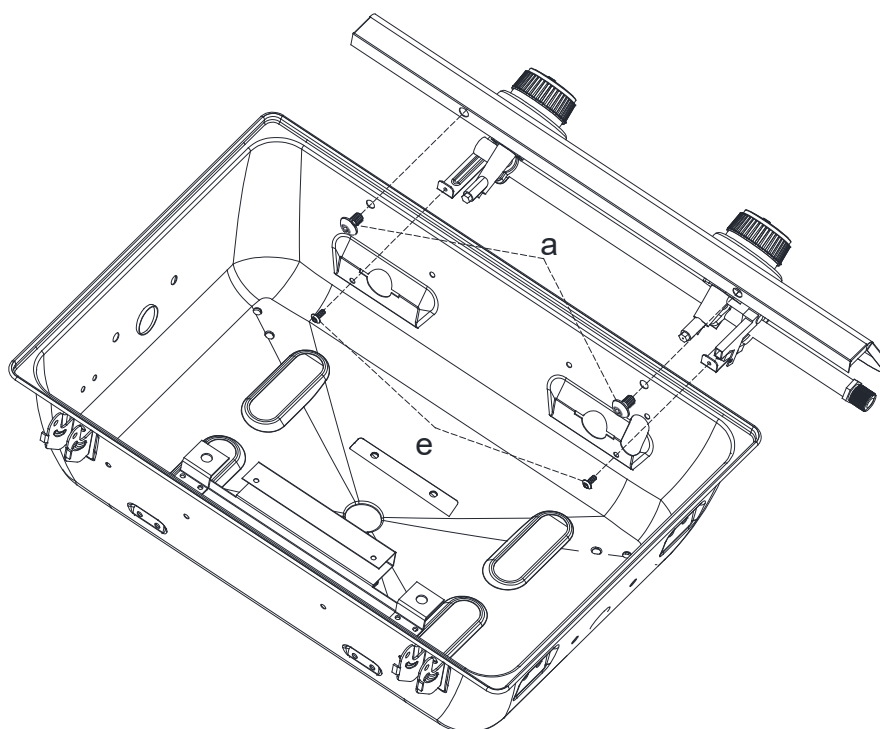
**a x 2**

M6x10

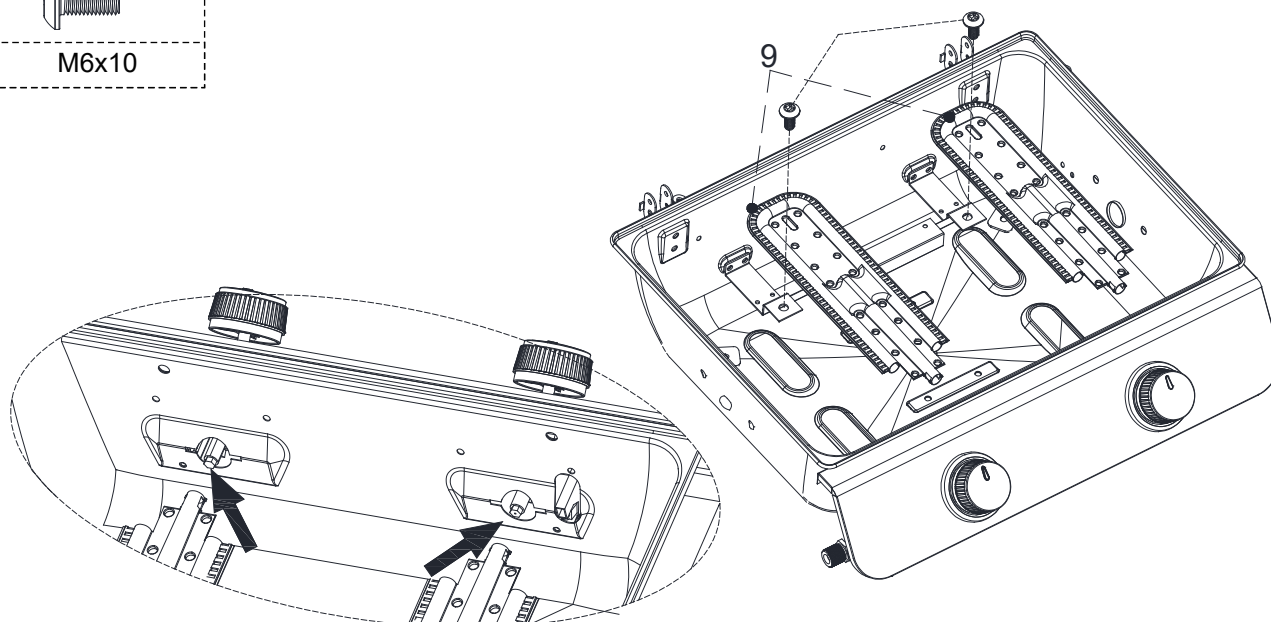

**Make sure the burner already insert into injector as below picture the tighten the screws.**

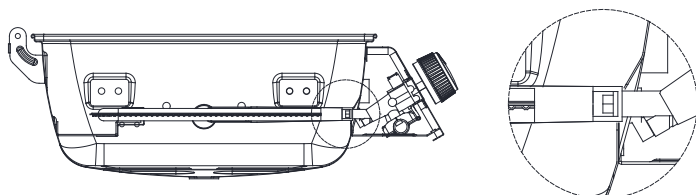

**c** x 4



M6x15

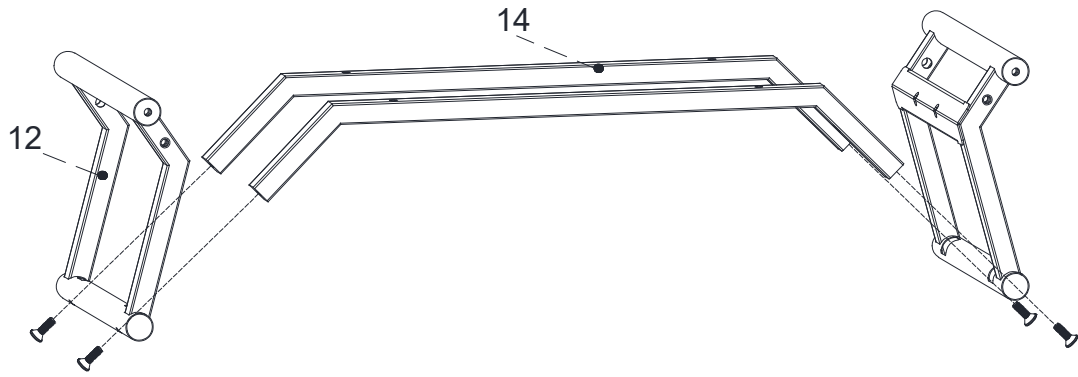

**b** x 4



M6x15

**f** x 4



M6

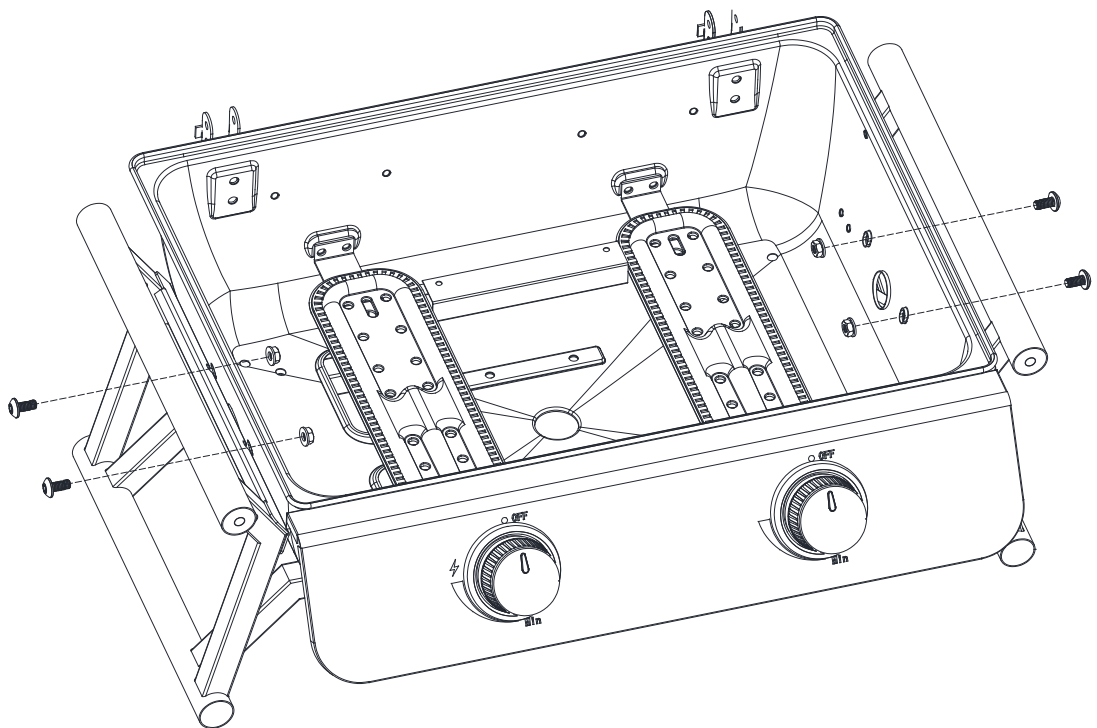

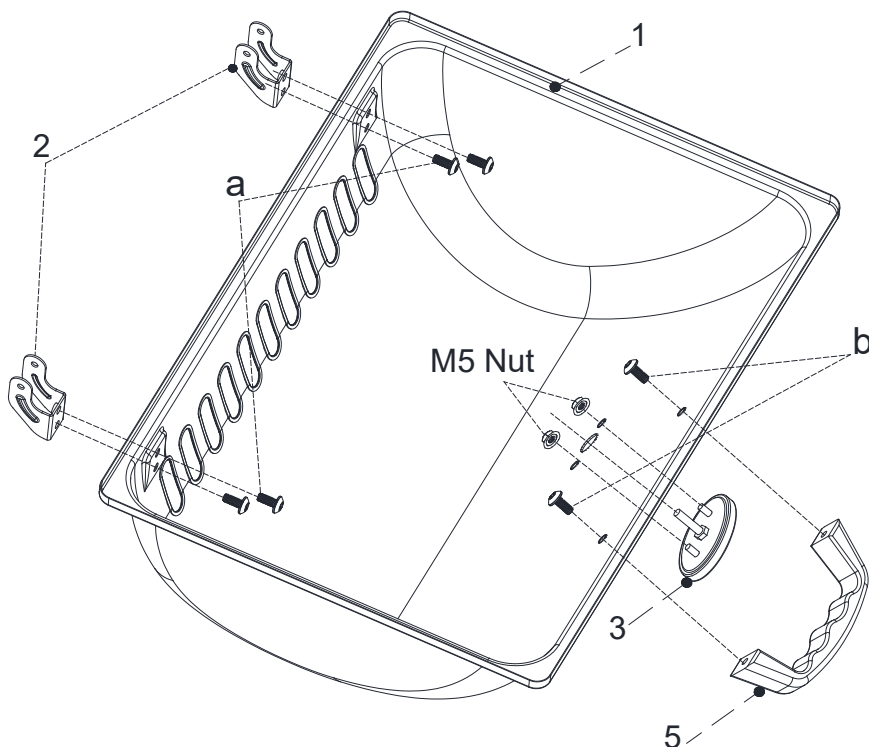
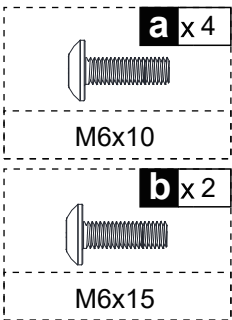
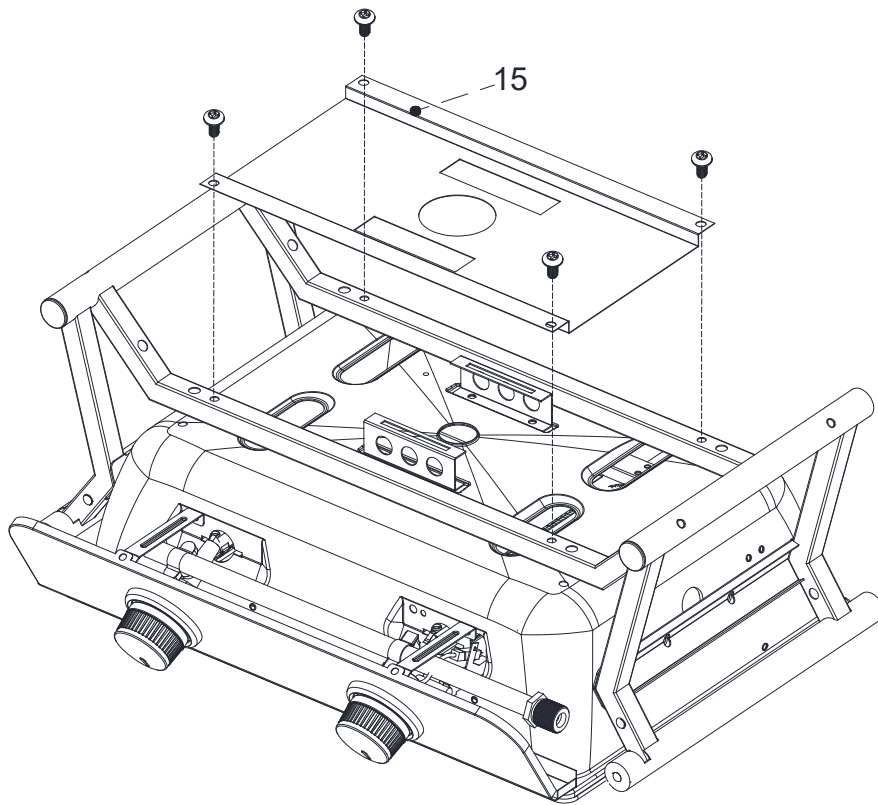
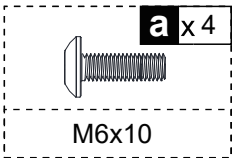

**h x 2**



Hinge Axle

**i x 2**



Clip

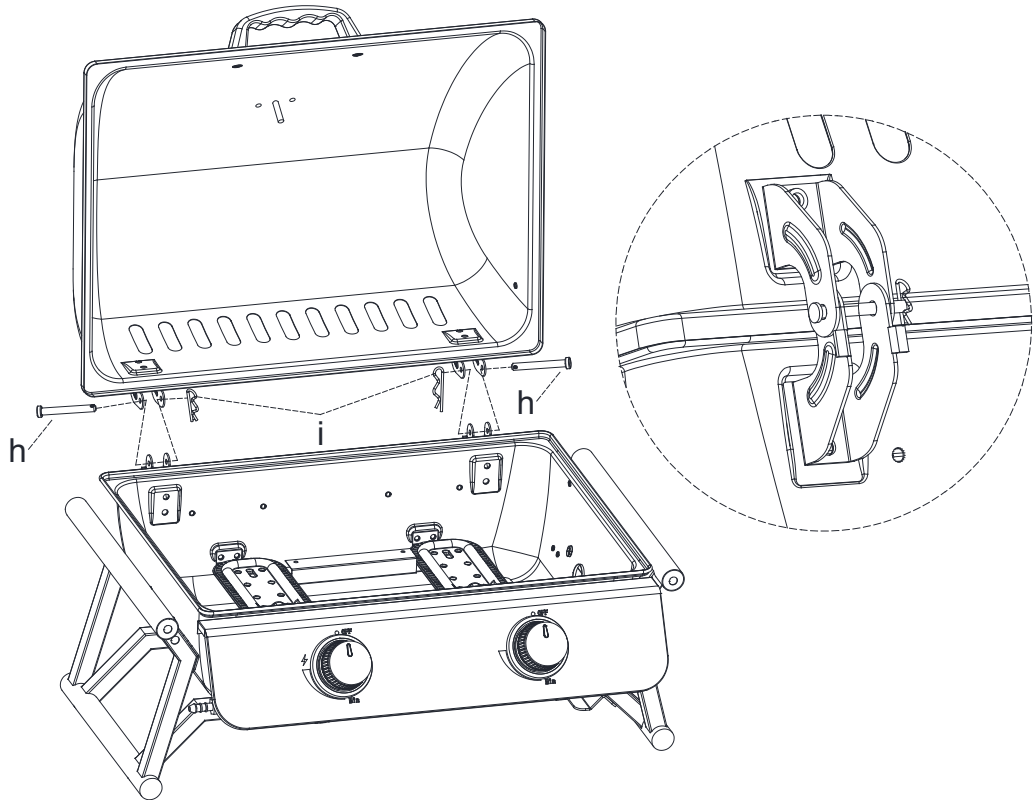

**d x 8**



M6x10

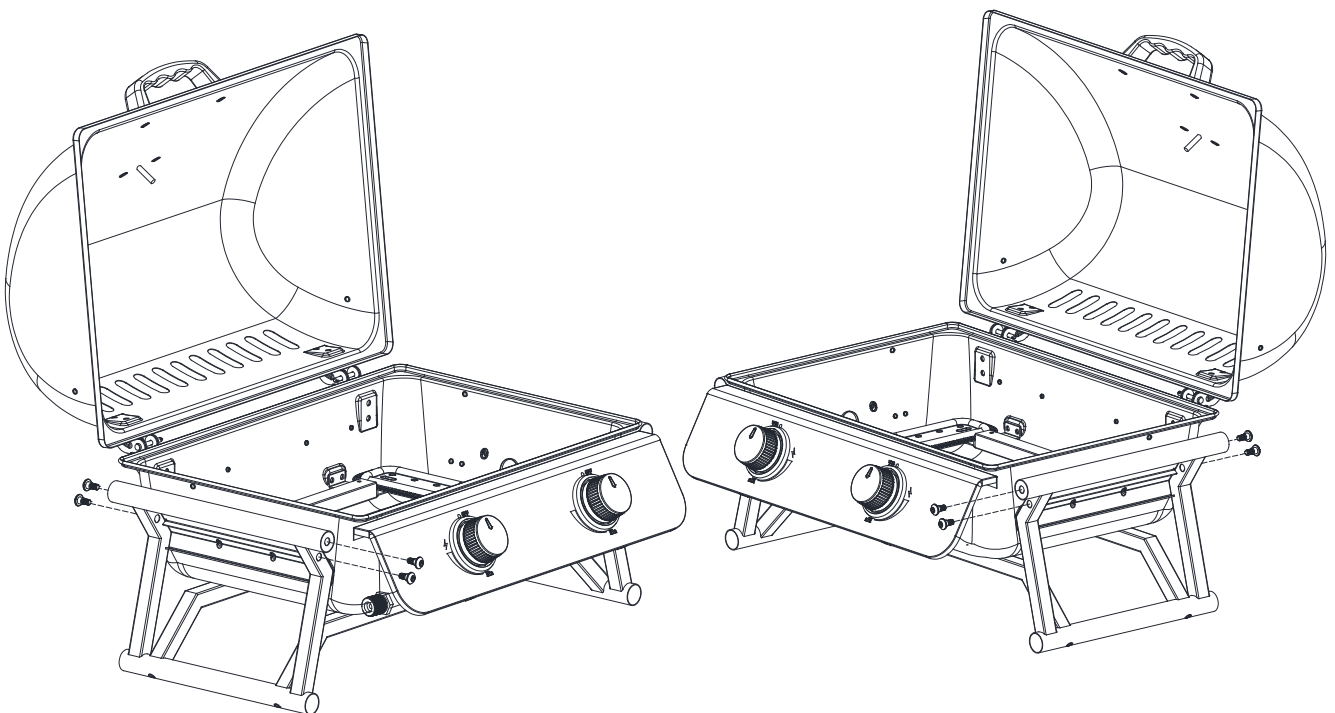

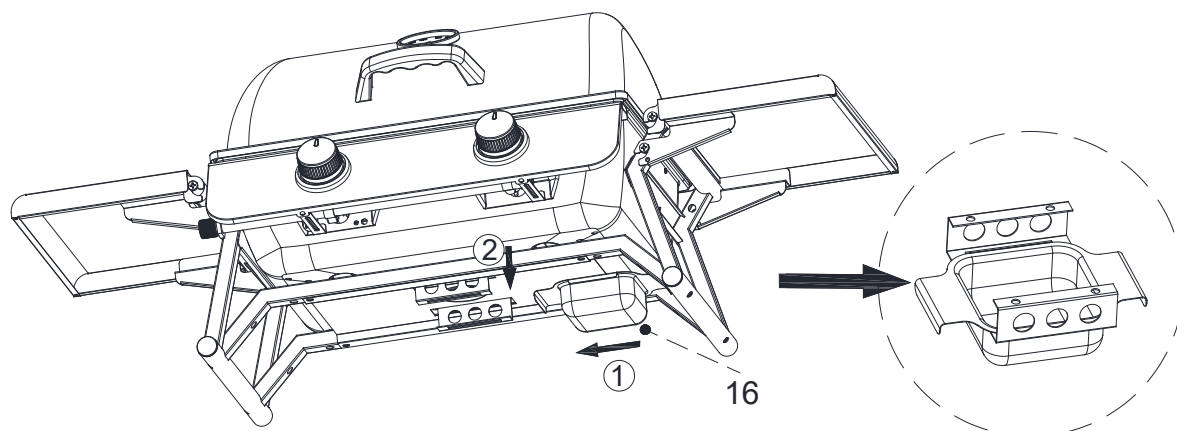
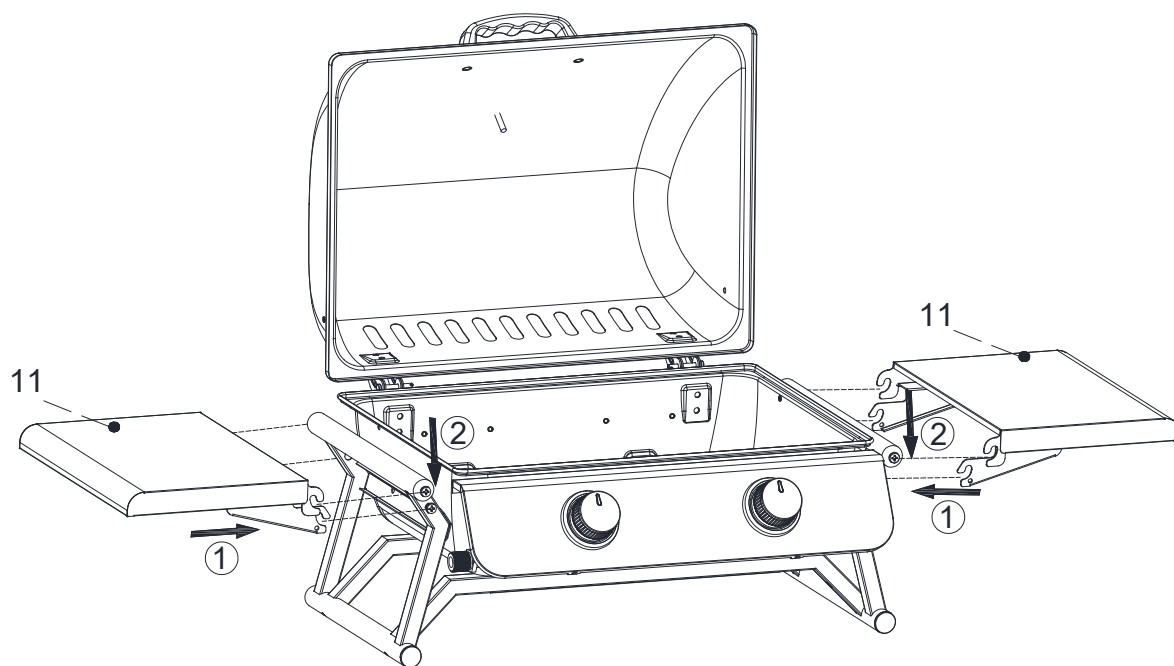

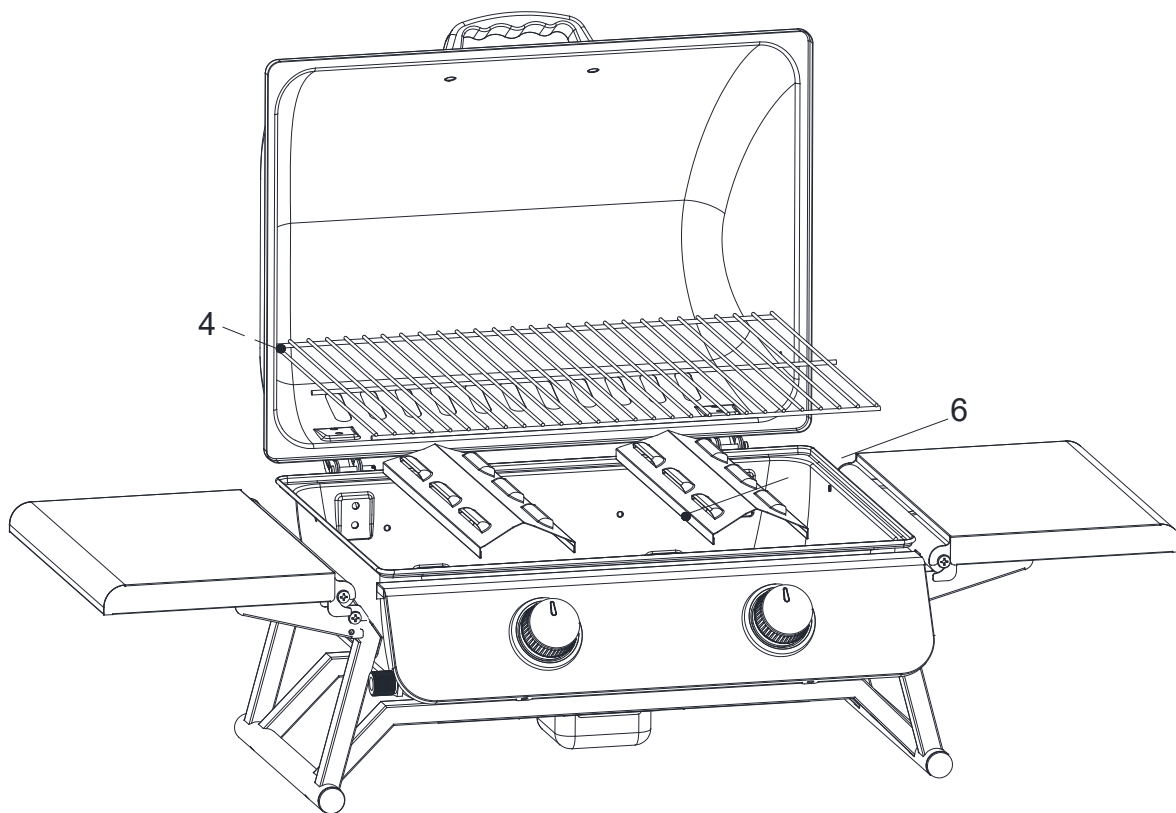

Regulator Assemble Instruction ( Regulator including in the package )

The grill operate with 28-30mbar regulator for butane , 37mbar regulator for propane.  
The regulator must certified to BSEN 16129 : 2013.  
The hose diameter is 8mm.

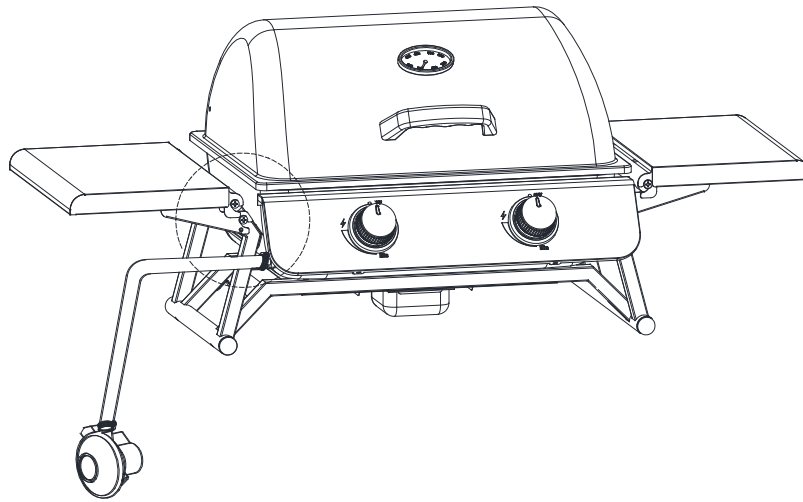

Insert the hose into grill connector

Fix the clip screw after insert the hose

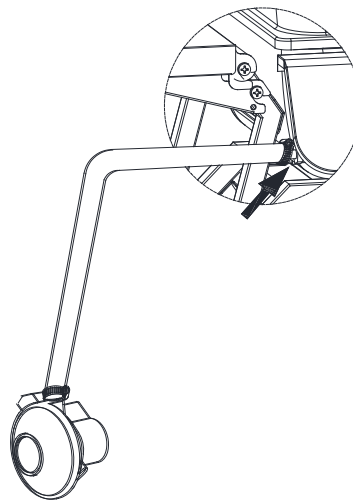
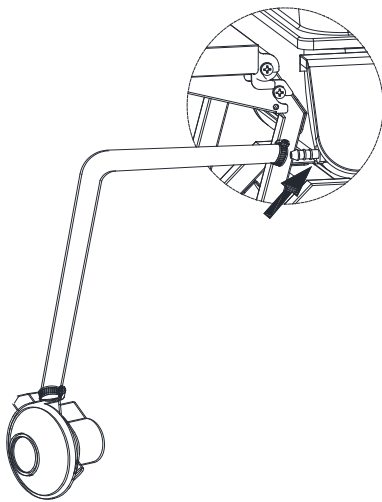

**Warning !!!**

Identify any leaks after assemble & before use ! ( Refer to Leak Test Instruction, Page 18 )  
Below connection are the parts which must test the leakage.

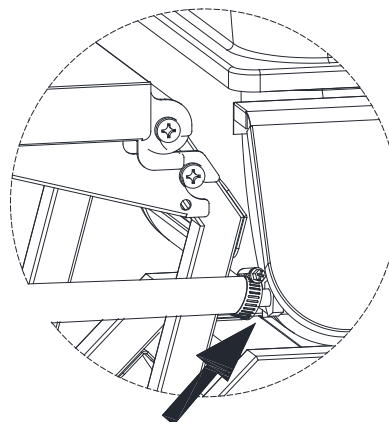
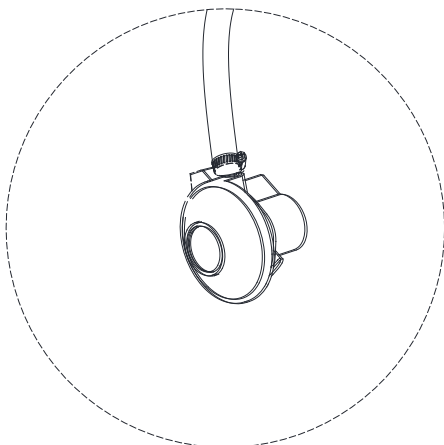

## **CONNECTING THE GAS CYLINDER TO THE APPLIANCE**

The appliance may only be used with butane, propane or a low pressure LPG mixture and with a suitable low pressure regulator and a flexible hose. The hose must be securely connected to the regulator and the appliance with hose clips. The barbecue operates with a 28-30 mbar regulator for butane, 37 mbar for propane and 30 mbar and 50 mbar for an LPG gas mixture. Use a suitable regulator certified to BSEN 16129: 2013. Contact your LPG supplier for further information on suitable regulators for gas cylinders.

## **REGULATOR & HOSE**

- These items are supplied with the barbecue  
Use only regulators and hoses intended for use with LPG at the pressures indicated above. The service life of a regulator is estimated at 10 years. It is recommended that you change the regulator 10 years after its date of manufacture.
- The hose should be changed when national regulations require. It is recommended that you change the hose 5 years after its date of manufacture.
- Using an unsuitable regulator or hose is dangerous. Ensure that the products that you have are suitable for use with your barbecue.
- The hose used must comply with the standards in force in the country of use. The hose must be a minimum of 0.6 metres long and a maximum of 1.5 metres. A damaged regulator or hose must be replaced. Ensure that the hose is not blocked, kinked or in contact with any part of the barbecue other than the connection point.

## **STORAGE AFTER USE**

- Store the appliance indoors only if the cylinder has been disconnected and removed. If the appliance is not used for a long period, it should be stored in its original packaging, in a dry, dust-free location.

## **Gas cylinder**

- The barbecue may be used with 11 or 15 kg cylinders. The maximum size is 310 mm (diameter) x 600 mm (height). The barbecue will run better if propane or LPG mixtures are used. Butane can be used but, due to the appliance's power, the cylinder will have a tendency to freeze and supply gas at a lower pressure, thus affecting the barbecue's performance. The gas cylinder must be outside the barbecue.
- The gas cylinder should be handled with care! Always disconnect the gas cylinder when not using the barbecue. Replace the protective cap on the cylinder when not connected to the appliance.
- Keep any source of ignition well away when changing the gas cylinder.
- Cylinders should always be stored outdoors, vertically and out of the reach of children. Cylinders should never be stored in temperatures in excess of 50°C. Never store gas cylinders close to flames, burners or other heat sources.

**NEVER SMOKE NEAR A GAS CYLINDER**

This barbecue is designed for outdoor use, well away from any flammable material. Ensure that any item located above the appliance cannot **obstruct** it and that both sides and the front of the appliance are at least 1 metre from any item that could impede its operation. Ensure that the appliance's ventilation holes are not obstructed. the barbecue should be place on a flat, stable surface. The appliance should be protected from direct draughts and bad weather (rain, etc.).

**Parts sealed by the manufacturer or its agent should not be disassembled by the user. Do not modify any part of the barbecue. Repairs and maintenance should only be carried out by an accredited technician.**

#### **Connecting the gas cylinder to the grill .**

- Before connection, ensure that nothing is obstructing the top of the cylinder, the regulator, burner or burner ports. Spiders and insects can get into and obstruct the burner's supply tube orifice. An obstructed burner could cause a fire under the appliance.
- Clean the burner orifices using a stout pipe cleaner.
- Secure the hose to the appliance using a spanner to tighten it on to the connection cable. When replacing the hose, it should be fixed to the appliance and to the regulator using hose clips. Disconnect the regulator from the cylinder (following the instructions supplied with the regulator) when the barbecue is not in use.

The barbecue should be used in a well ventilated area. Do not obstruct the flow of combustion air to the burner when using the barbecue. THIS BARBECUE IS ONLY FOR OUTDOOR USE.

**IDENTIFY ANY LEAKS BEFORE USE. IDENTIFY ANY LEAKS BEFORE USE.**

**TAKE GREAT CARE!!!**

**If there is a gas leak, switch off the gas supply immediately.**

#### **LEAK TEST**

- Mix one part washing up liquid to three parts water to make 60 to 90 ml of leak finding solution.
- Ensure that the control valve is closed.
- Connect the regulator to the cylinder and the open/close valve to the burner. Ensure that connections are correctly made and then open the gas inlet valve.
- Spread the solution over the hose and all joins with a brush. If any bubbles appear, then there is a leak, which must be repaired before the barbecue is used.
- Test again, once the leak is repaired.
- Close the gas inlet valve on the cylinder, when the test is complete.
- If a leak is detected which cannot be repaired, do not attempt any other action but contact your distributor.

#### **Lighting Instruction for Main Burner**

1. Open the lid.
2. Turn the control knobs clockwise to the off position.
3. Connect the regulator to the gas cylinder. Open the gas inlet valve on the cylinder. Using a

soap solution, look for any gas leak between the cylinder and the regulator.

4. Push down the first control knob and turn it anti-clockwise to the ⚡ position, this will light the first burner. Always turn on the first burner first.

5. Turn other burners on by turning the control knob to “HI” position. They will be light through flame channel. Always start from left side to right side burner.

6. Adjust the power of the flame by turning the knob to the High/Low position.

7. If the burner does not light, light it with a match in the orifice at the side of the appliance. Contact your gas distributor to have the ignition system repaired.

8. To switch the barbecue off, close the valve on the cylinder or the switch on the regulator if you have finished using the barbecue, then turn the appliance's control knobs clockwise to “OFF “ position.

### **Notice for first time using**

Close the hood and left the gas burn at Min setting for 15 minutes.

The smells from the treated surface are eliminated by the high temperature.

## **CLEANING & MAINTENANCE**

### **General Warning**

- Before cleaning, wait until the gas barbecue has cool down sufficiently.
- Before cleaning, remove the gas cylinder.
- Do not use any flammable detergents.
- Do not use wire brush or other abrasive utensils for cleaning.
- Do not use any oven cleaners. Oven cleaner attacks painted surface.
- Clean the barbecue after each use.

### **Exterior surface**

- Use mild detergents, caustic soda and hot water.
- Mild abrasive agents can be used for stubborn stains.
- Following this, rinse thoroughly with water.

### **Interior surface**

Does the inner surface of the grill lid looks as paint may flake? There is burnt-on grease which is flaking.

- Clean the surface thoroughly with highly concentrated , hot soap suds.
- Rinse thoroughly with water and allow the lid to dry.

### Interior surface of the barbecue bottom

- Remove residue with a brush or a scraper.
- Using soap suds and a sponge, finish by washing the surface.
- Rinse thoroughly with water and allow the surface to dry.

### Cooking grid & Warming Rack

- Use mild soap suds.
- Mild abrasive agents can be used for stubborn stains.
- Following this, rinse thoroughly with water.

### Clean the burner

- Turn the gas OFF at the control knob and disconnect the cylinder.
- Remove cooling grate.
- Clean the burner with a soft brush or blow clean with compressed air and wipe with a cloth.
- Clean any clogged ports with a pipe cleaner or stiff wire (such as an opened paper clip).
- Inspect burner for any damage (cracks or holes). If damage is found, replace with a new burner. Reinstall the burner, check to ensure that the Gas valve orifices are correctly positioned and secured inside the burner inlet (venturi).

### Store the gas barbecue

- Before storage , please ensure the barbecue is clean and dry.
- Store the barbecue in a dust-free, dry room.
- Always use a cover to protect the barbecue to avoid rust.

## Trouble Shooting

Problem	Possible cause	Solution
Burners will not light using the ignition system	LP gas cylinder is empty.	Replace with full cylinder
	Faulty regulator.	Have regulator checked or replace
	Obstructions in the burner	Clean burner
	Obstructions in gas jet and hose	Clean jets and gas hose
	Electrode wire loose or disconnected on electrode or ignition unit	Reconnect wire
	Electrode or wire is damaged	Change electrode and wire
	Faulty push button igniter	Change igniter
Low flame or flashback (fire in burner tube-a hissing or roaring noise may be heard)	LP gas cylinder too small	Use larger cylinder
	Obstructions in burner	Clean burner
	Obstructions in gas jets or gas hose	Clean jets and gas hose
	Windy conditions	Use BBQ in a more sheltered position
Difficulty turning control knob	Control Knob Broken	Replace control knob
	Gas valve jammed	Replace gas valve

**UK**

If you have any questions, please contact our customer care center.

Our contact details are below:



0044-800-240-4004



enquiries@mhstar.co.uk

IMPORTER ADDRESS:

MH STAR UK LTD  
Unit 27, Perivale Park,  
Horsenden lane South  
Perivale, UB6 7RH  
MADE IN CHINA

**ES**

Si tiene alguna pregunta, comuníquese con nuestro Centro de Atención al Cliente. Nuestros datos de contacto son los siguientes:



0034-931294512



atencioncliente@aosom.es

Importador/REP:

Spanish Aosom, S.L.  
C/ Roc Gros, nº 15. 08550, Els Hostalets de Balenyà,  
Spain.  
B66295775  
HECHO EN CHINA

**FR**

Si vous avez la moindre question, veuillez contacter notre centre d'assistance à la clientèle.

Nos coordonnées sont les suivantes:



0033-1-84166106



aosom@mhfrance.fr

Importé par/REP :

MH France  
2, rue Maurice Hartmann  
92130 Issy-les-Moulineaux  
France  
Fabriqué en Chine

**PT**

Se tiver alguma dúvida, por favor contacte o nosso Centro de Atendimento ao Cliente. Os nossos dados de contacto são os seguintes:



0034-931294512



info@aosom.pt.

IMPORTADOR:

SPANISH AOSOM, S.L  
C.ROC GROS N.15, 08550. ELS HOSTALETES DE BALENYÀ  
TEL: 931294512 (SEG-SEX DAS 7:30H ÀS 16:30H)  
INFO@AOSOM.PT  
FEITO NA CHINA

**DE**

Wenn Sie Fragen haben, wenden Sie sich bitte an unser Kundendienstzentrum.

Unsere Kontaktdaten stehen unten:



0049-0(40)-88307530



service@aosom.de

Importeur/REP:

MH Handel GmbH  
Wendenstraße 309  
D-20537 Hamburg  
Germany  
IN CHINA HERGESTELLT

**IT**

In caso di dubbio, si prega di contattare il nostro centro assistenza clienti.

I nostri dettagli di contatto sono di seguito:



0039-0249471447



clienti@aosom.it

IMPORTATO DA/REP:

AOSOM Italy srl  
Centro Direzionale Milanofiori  
Strada 1 Palazzo F1  
20057 Assago (MI)  
P.I.: 08567220960  
FATTO IN CINA

