

PawHut

IN250800130V01_GL

D32-045V00

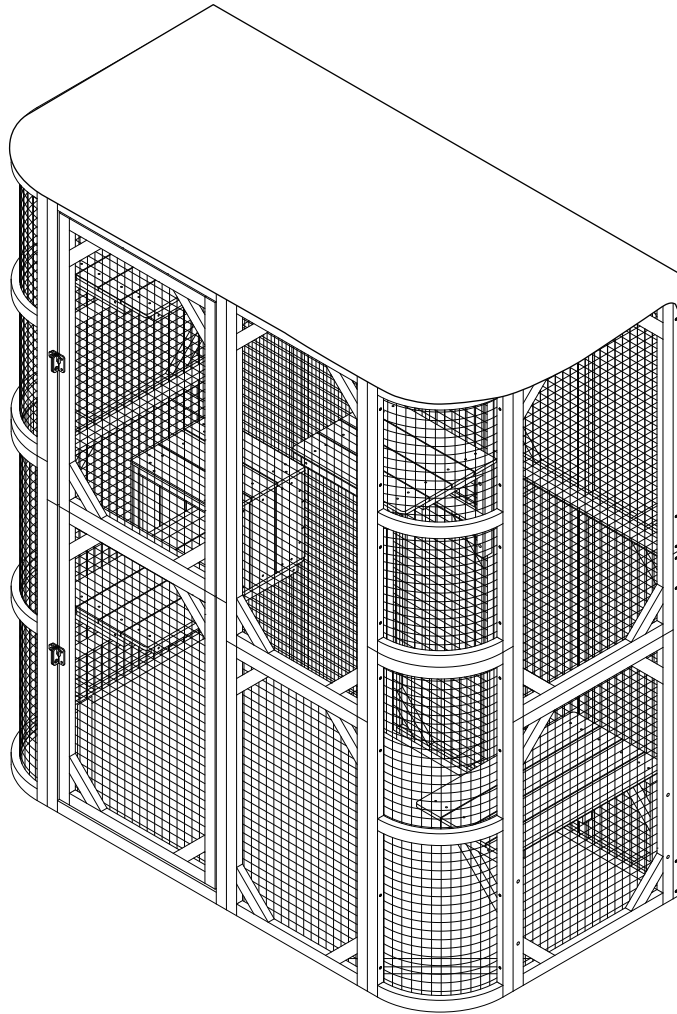

31

STEPS



4 HR



EN_IMPORTANT, RETAIN FOR FUTURE REFERENCE: READ CAREFULLY.

FR_IMPORTANT: A LIRE ATTENTIVEMENT ET À CONSERVER POUR CONSULTATION ULTÉRIEURE.

ES_IMPORTANTE, LEA Y GUARDE PARA FUTURAS REFERENCIAS.

PT_IMPORTANTE, RETER PARA REFERÊNCIA FUTURA: LEIA ATENTAMENTE.

DE_WICHTIG! SORGFÄLTIG LESEN UND FÜR SPÄTER NACHSCHLAGEN AUFBEWAHREN.

IT_IMPORTANTE! CONSERVARE IL PRESENTE MANUALE PER FUTURO RIFERIMENTO E LEGGERLO ATTENTAMENTE.

BOX
1-2

1 x 1

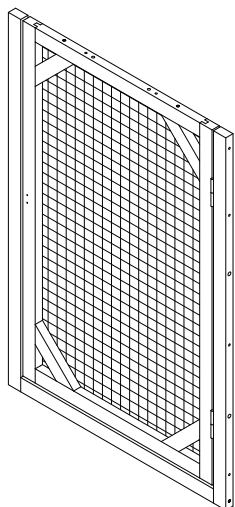

2 x 1

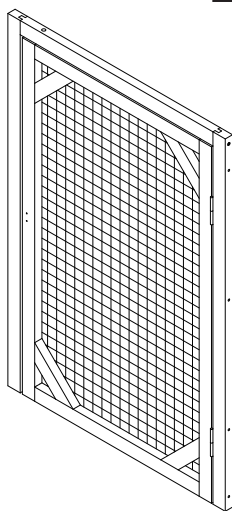

3 x 1

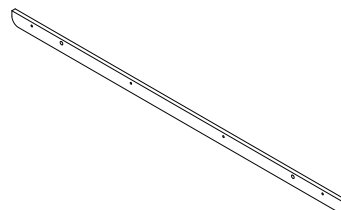

6 x 1

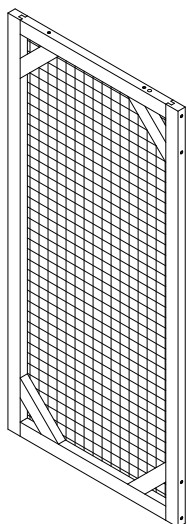

7 x 1

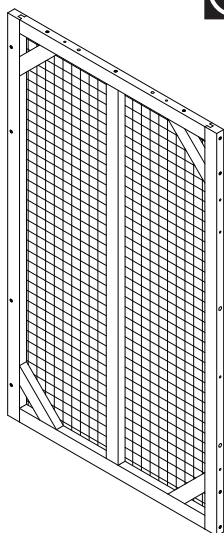

9 x 1

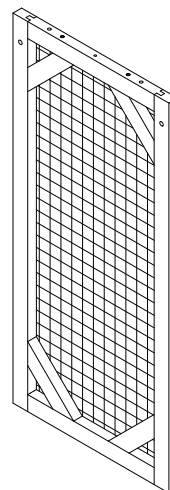

10 x 1

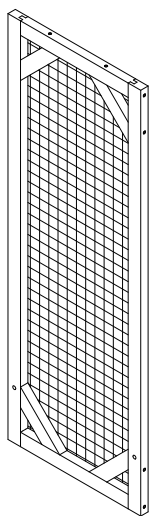

11 x 1

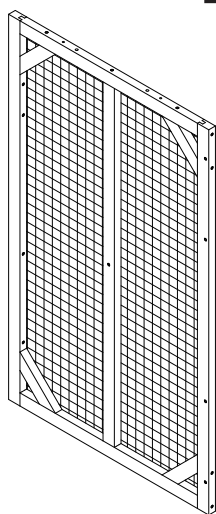

14 x 1

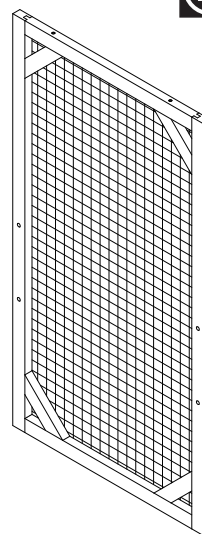

BOX
1-2

15 x 1

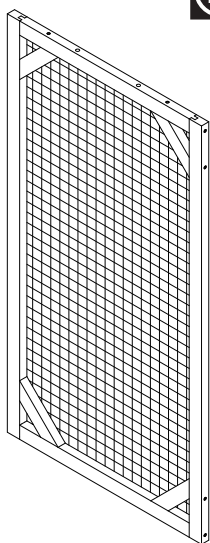

16 x 2

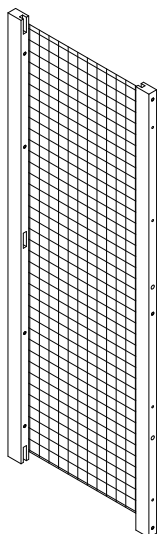

17 x 2

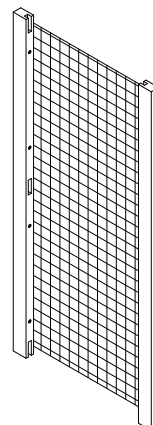

18 x 8



19 x 2



20 x 2



26 x 2

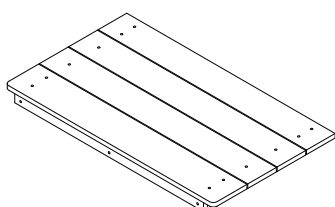

28 x 8

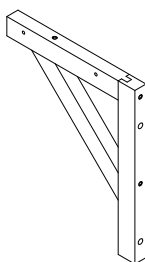

30 x 2

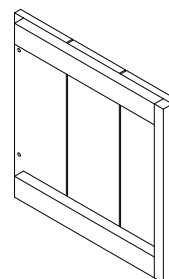

BOX
2-2

4 x 1

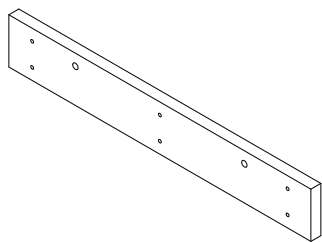

5 x 1

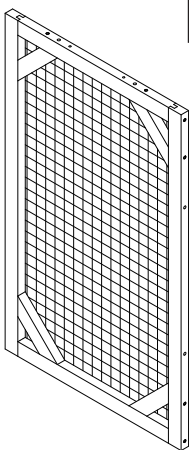

8 x 1

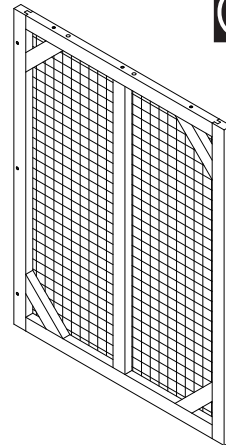

12 x 1

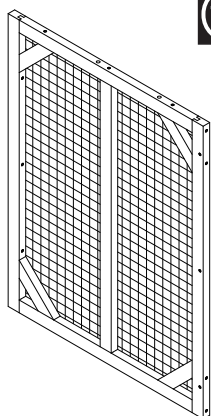

13 x 2

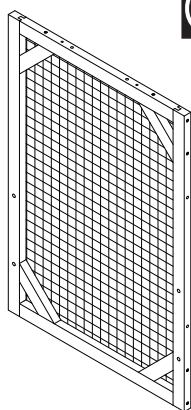

21 x 12

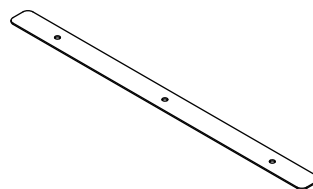

22 x 1

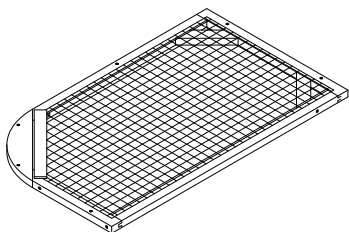

23 x 1

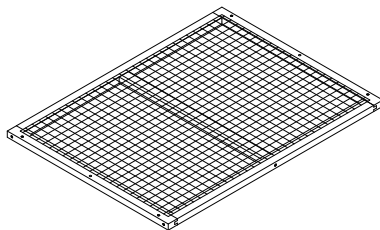

24 x 1

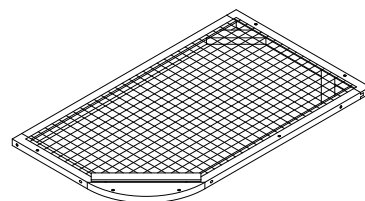

25 x 1

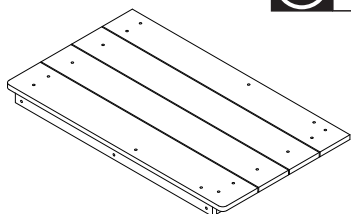

27 x 1

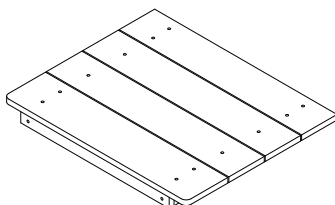

29 x 1

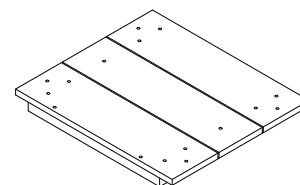

31 x 1

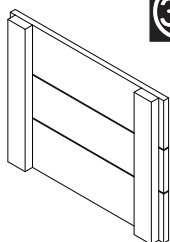

32 x 2

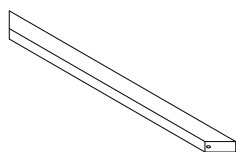

33 x 1

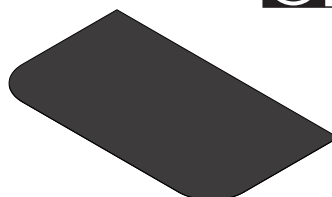

Hardware Kit

A x71
3.5*60
+1 (spare)



B x24
3.5*50
+1(spare)



C x37
3.5*40
+1(spare)



D x46

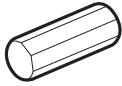

E x16
M6*60
+1(spare)

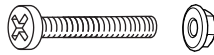

F x16
3.0*35
+1(spare)



G x 6
3.0*30
+1(spare)



H x16
3.0*25
+1(spare)



I x16
3.5*16
+2(spare)



J x36
4.0*16
+3(spare)



K x 2

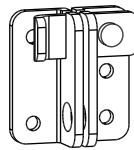

L x 4

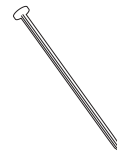

M x 4

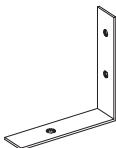

D x 10

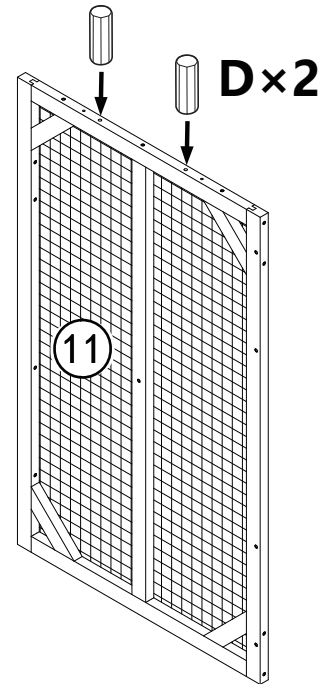
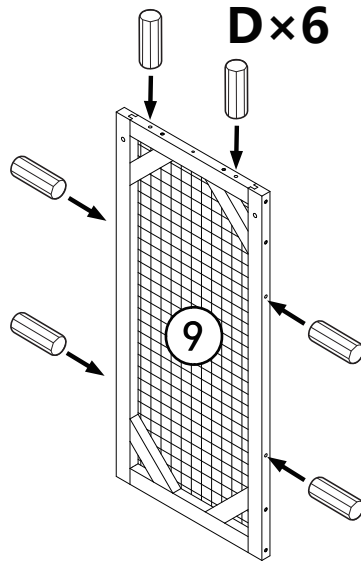
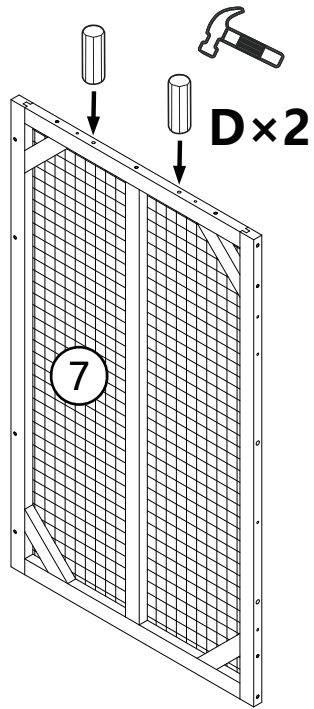

A x 5



3.5*60

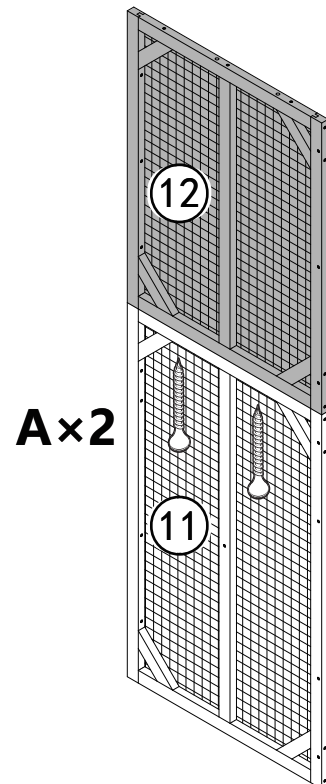
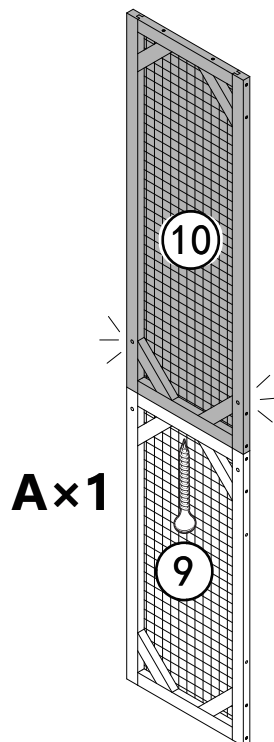
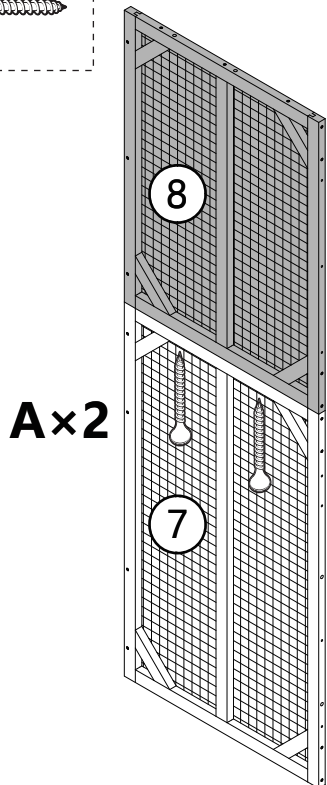

A x14



3.5*60

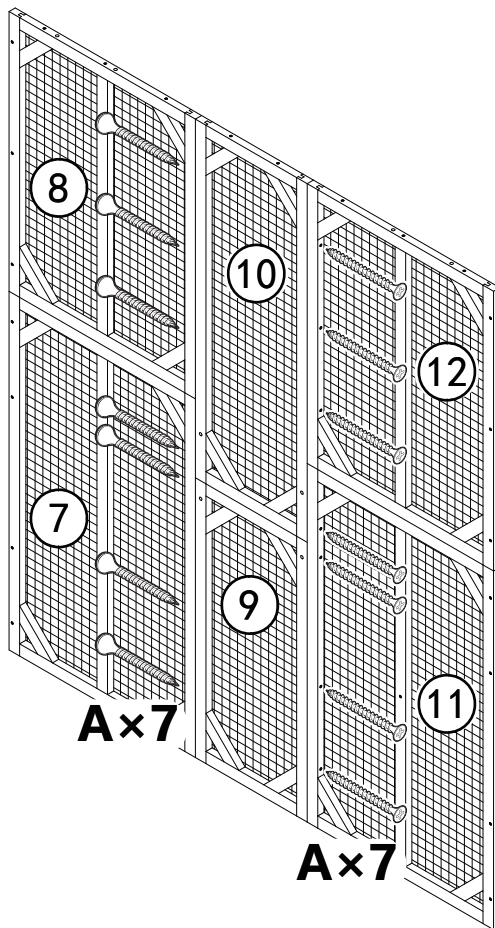

F x12



3.0*35

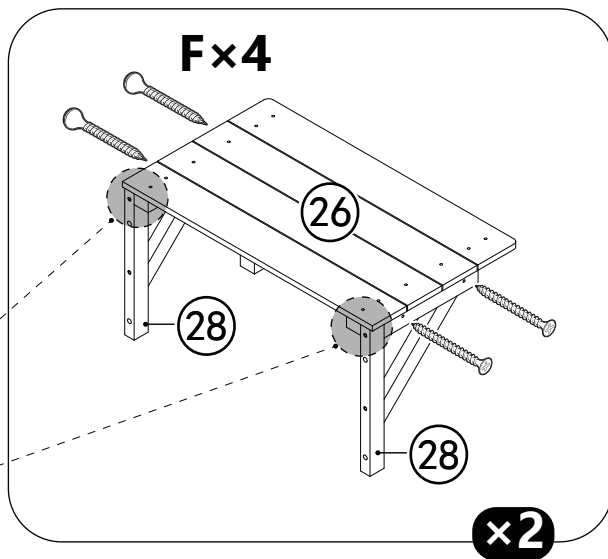
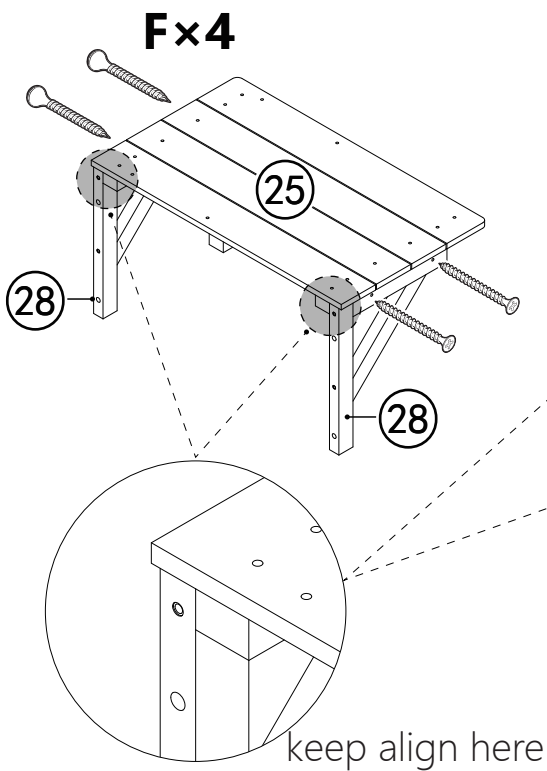

H x 4



3.0*25

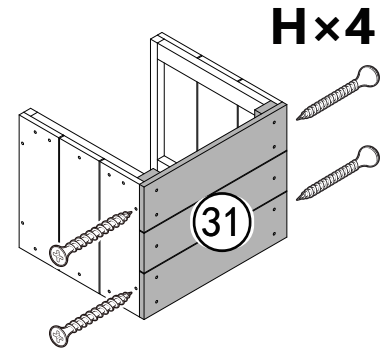
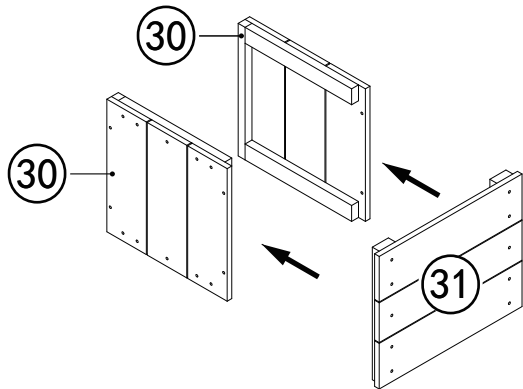

H x 4



3.0*25

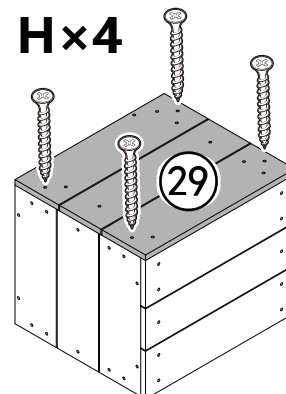
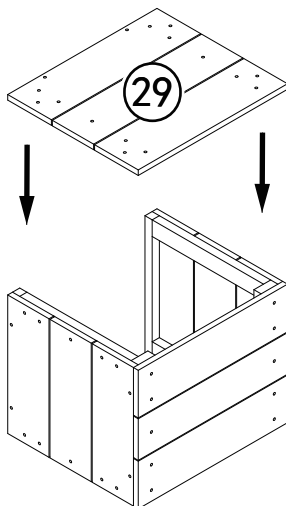

EN The outer edges shall be kept flush all around.

FR Les bords extérieurs doivent être maintenus à fleur tout autour.

ES Los bordes exteriores se mantendrán alineados en todo su contorno.

PT As bordas externas devem ser mantidas niveladas em toda a volta.

DE Die Außenkanten müssen rundum bündig gehalten werden.

IT I bordi esterni devono essere mantenuti a filo su tutto il perimetro.

H x 4

3.0*25

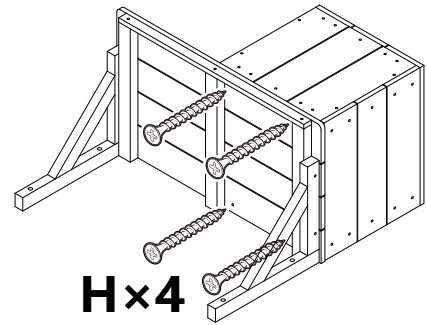
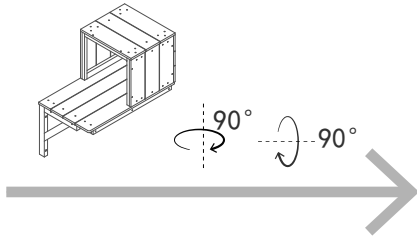
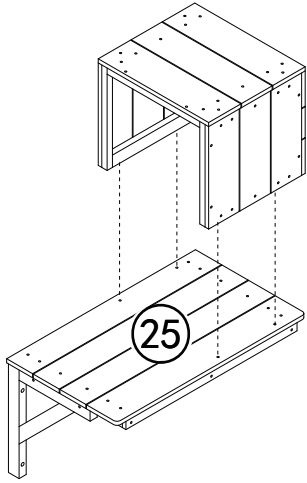

E x 8

M6*60



D x 12

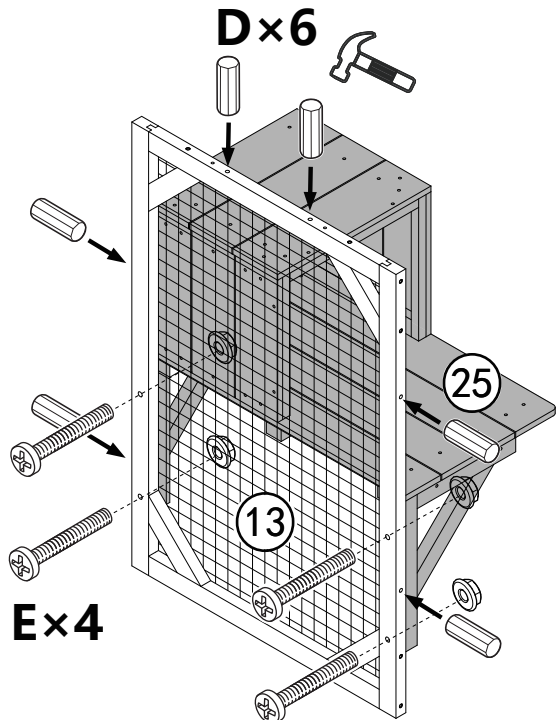
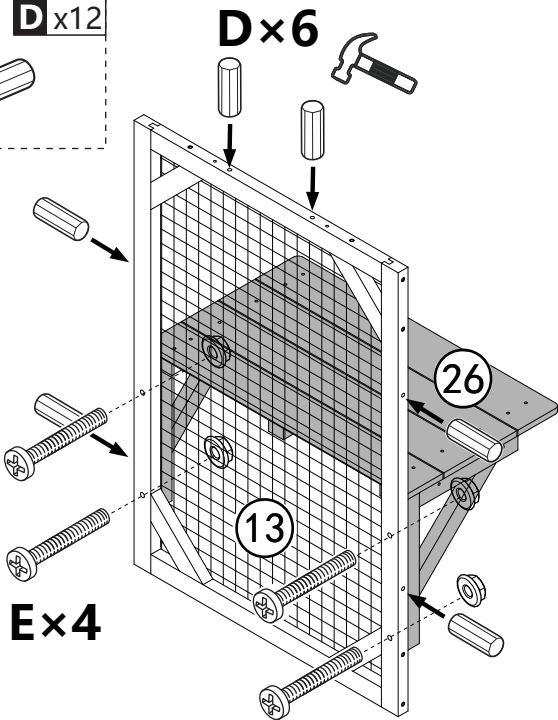

C x 7

3.5*40

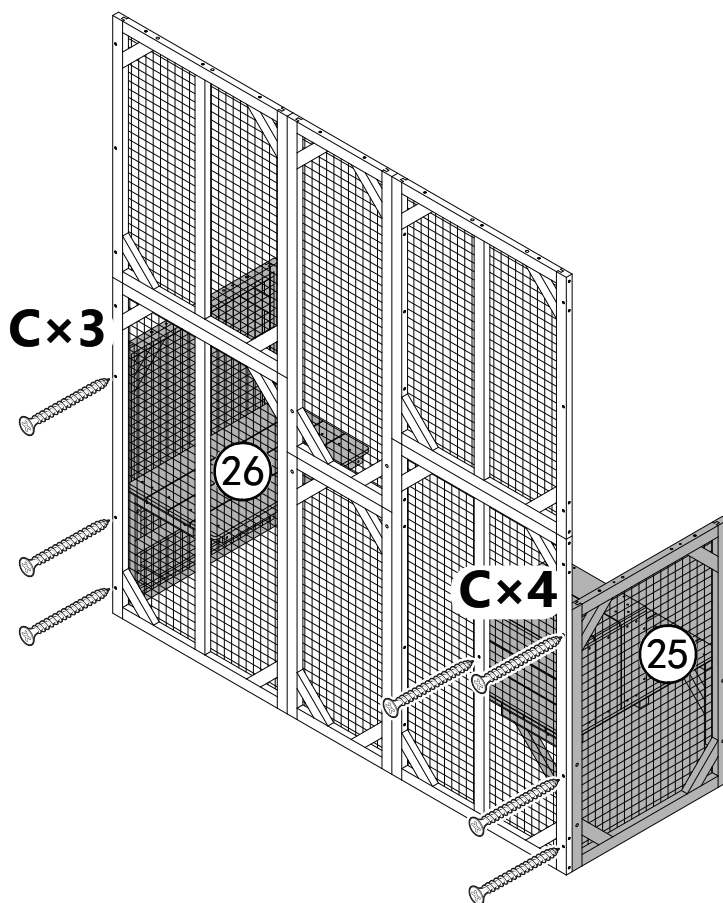
**E** x 4

M6*60

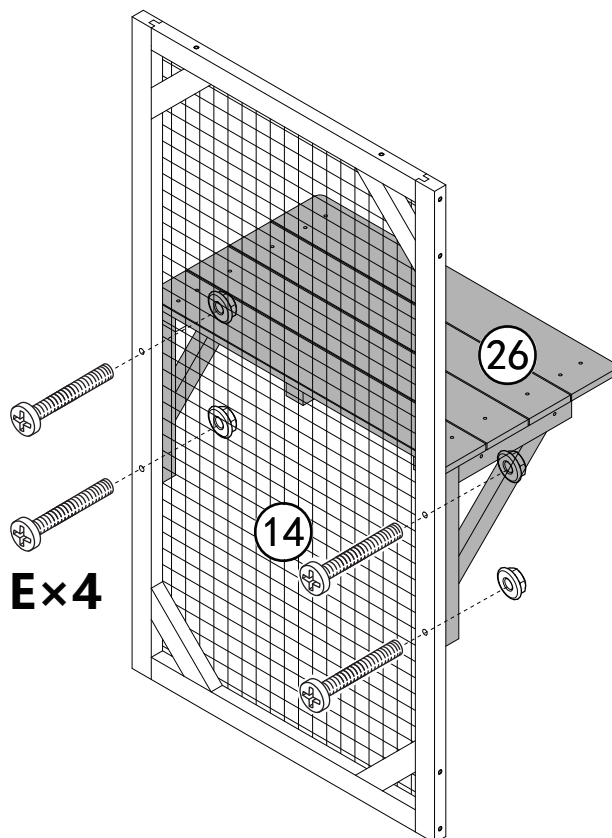

A x 2



3.5*60

C x 8



3.5*40

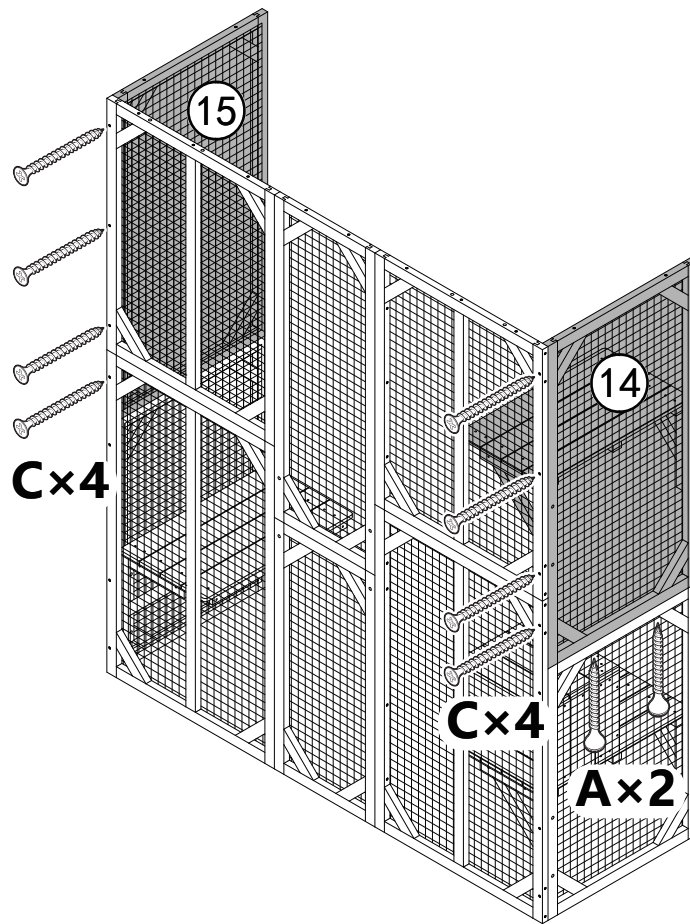

F x 4



3.0*35

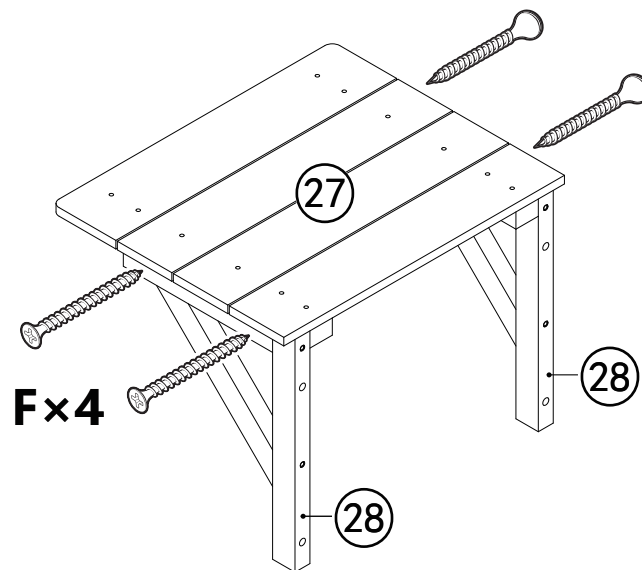

A x 2



3.5*60

E x 4



M6*60

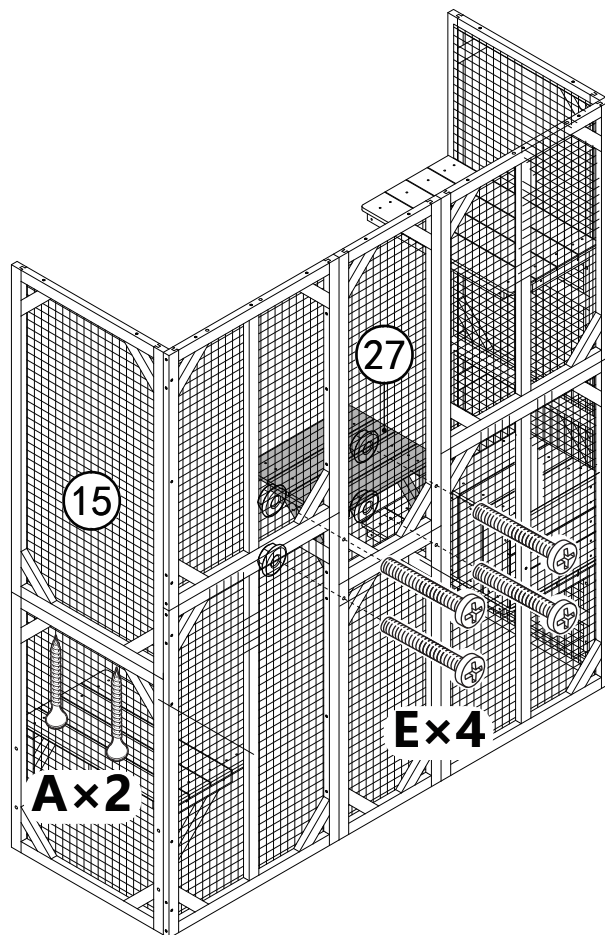

B x 12



3.5*50

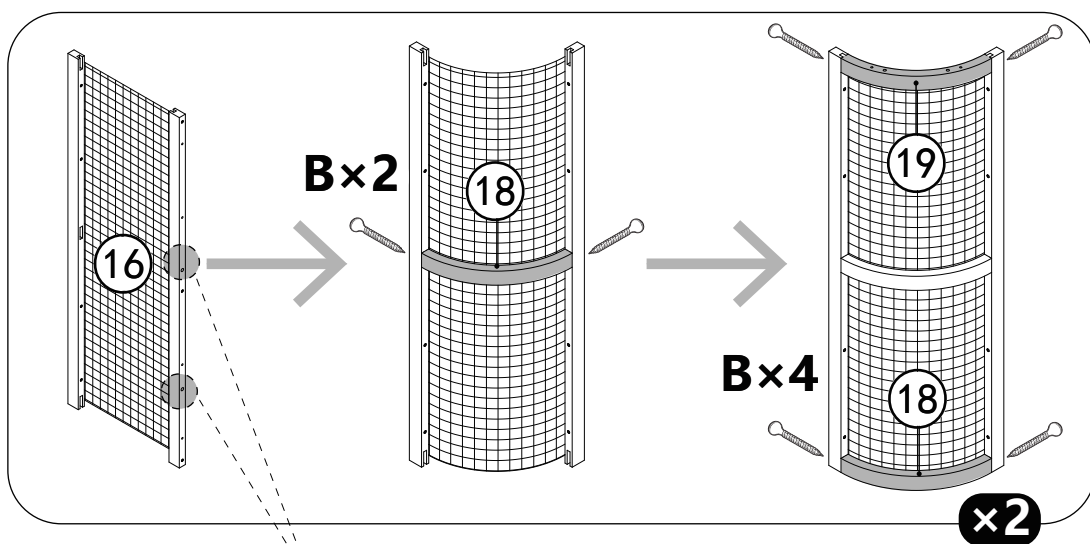

EN When installing, the wood core hole of Part 16 shall be positioned at the bottom.
 FR Lors de l'installation, le trou central en bois de la pièce 16 doit être positionné vers le bas.
 ES Durante la instalación, el orificio del núcleo de madera de la pieza 16 deberá colocarse en la parte inferior.
 PT Durante a instalação, o orifício central da Parte 16 deve ser posicionado na parte inferior.
 DE Bei der Installation muss die Holzkernbohrung von Teil 16 unten positioniert werden.
 IT Durante l'installazione, il foro centrale in legno della parte 16 deve essere posizionato nella parte inferiore.

B x12



3.5*50

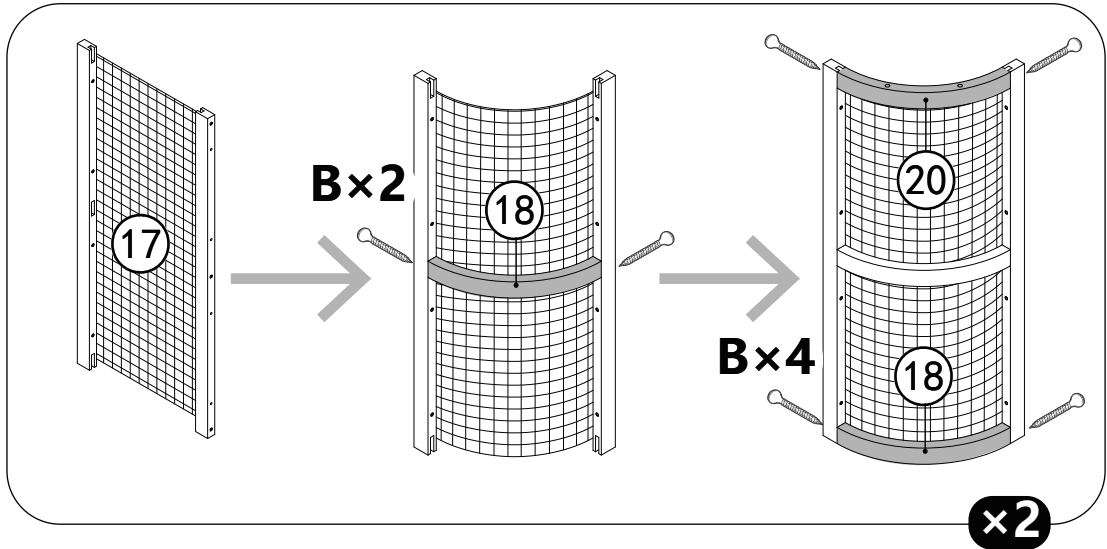

J x36



4.0*16

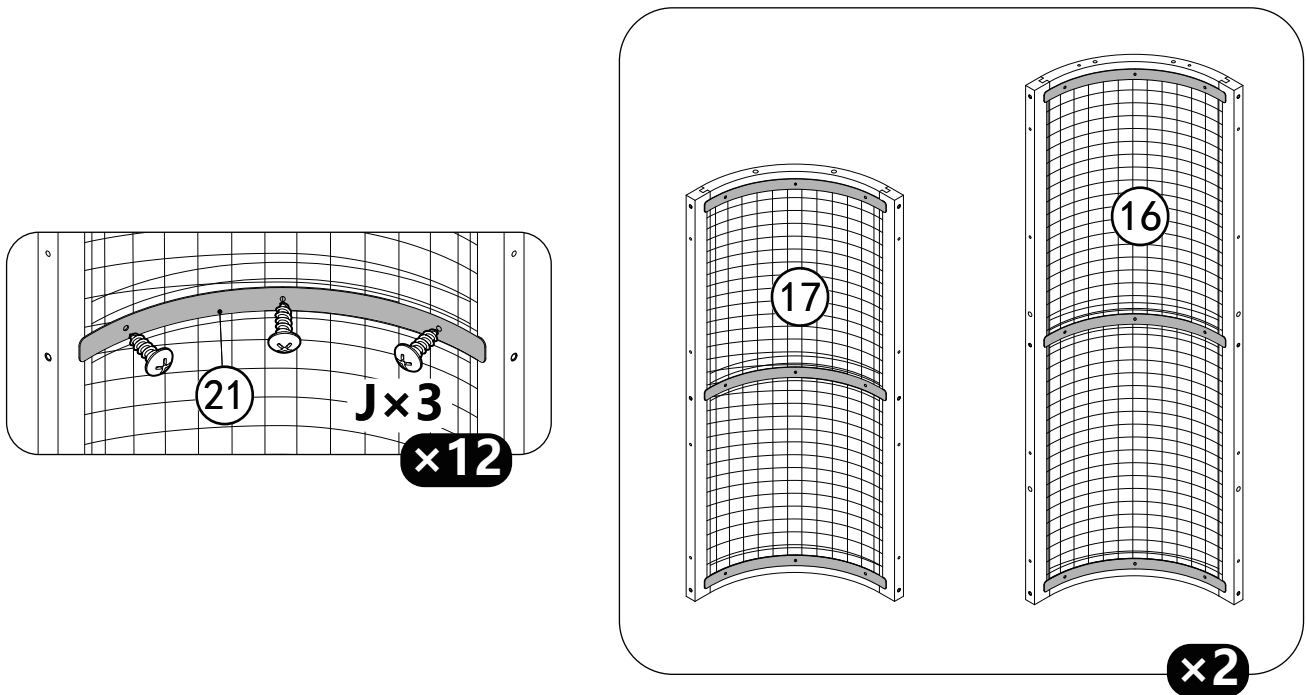

A x 4



3.5*60

D x 4



D x 2

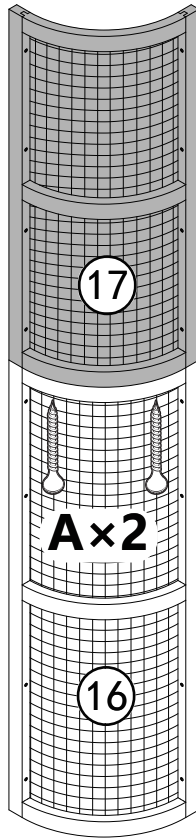
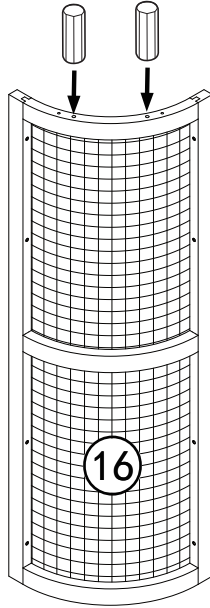

x2

A x 16



3.5*60

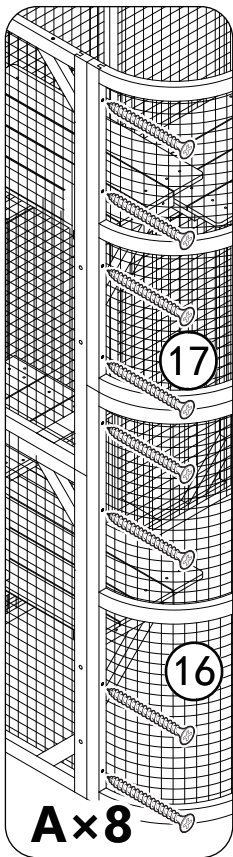

A x 8

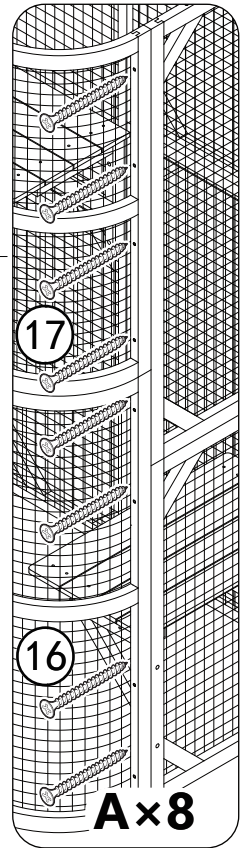
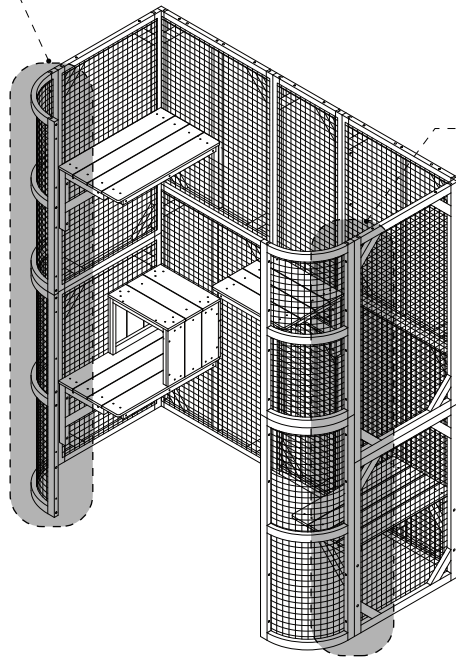

A x 8

A x 2



3.5*60

D x 6

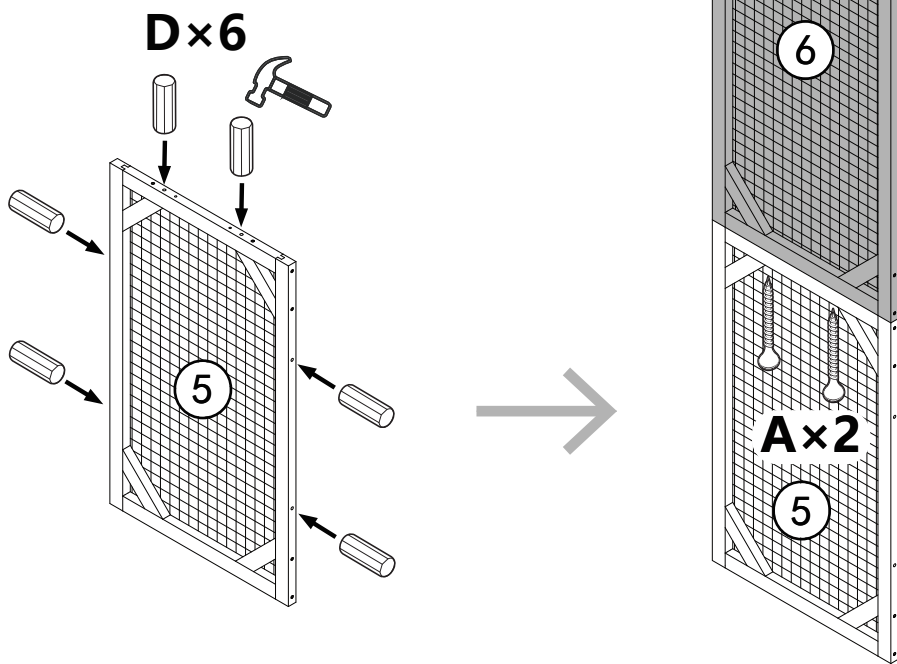

A x 8



3.5*60

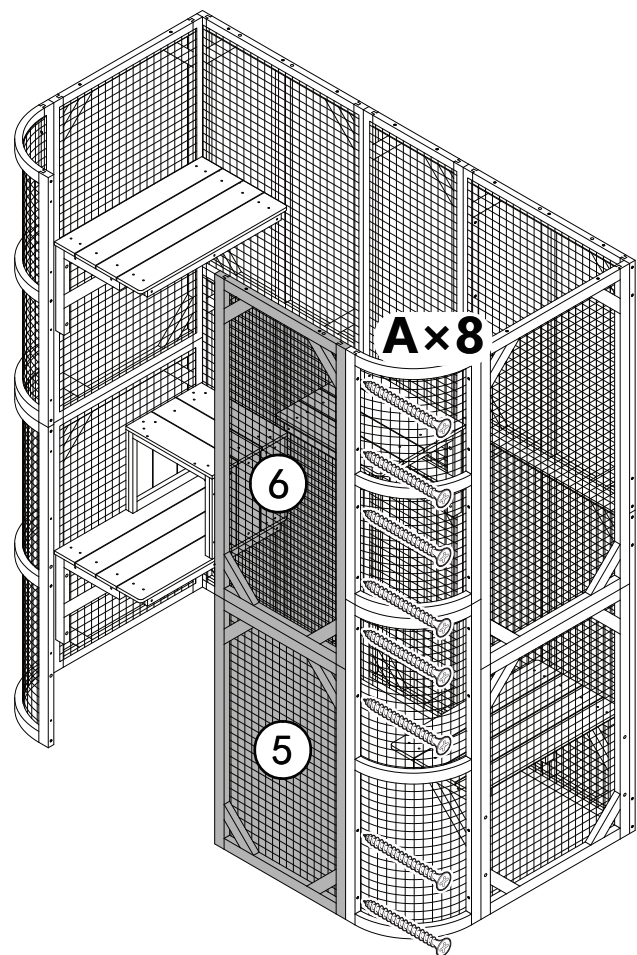

D x 4

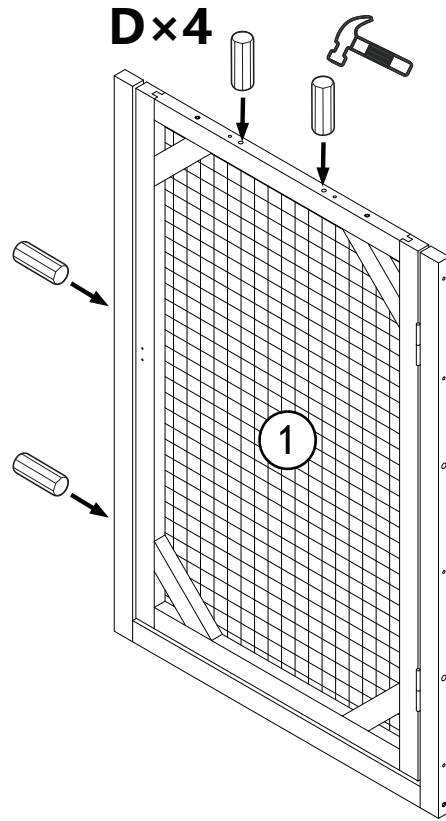

A x 2



3.5*60

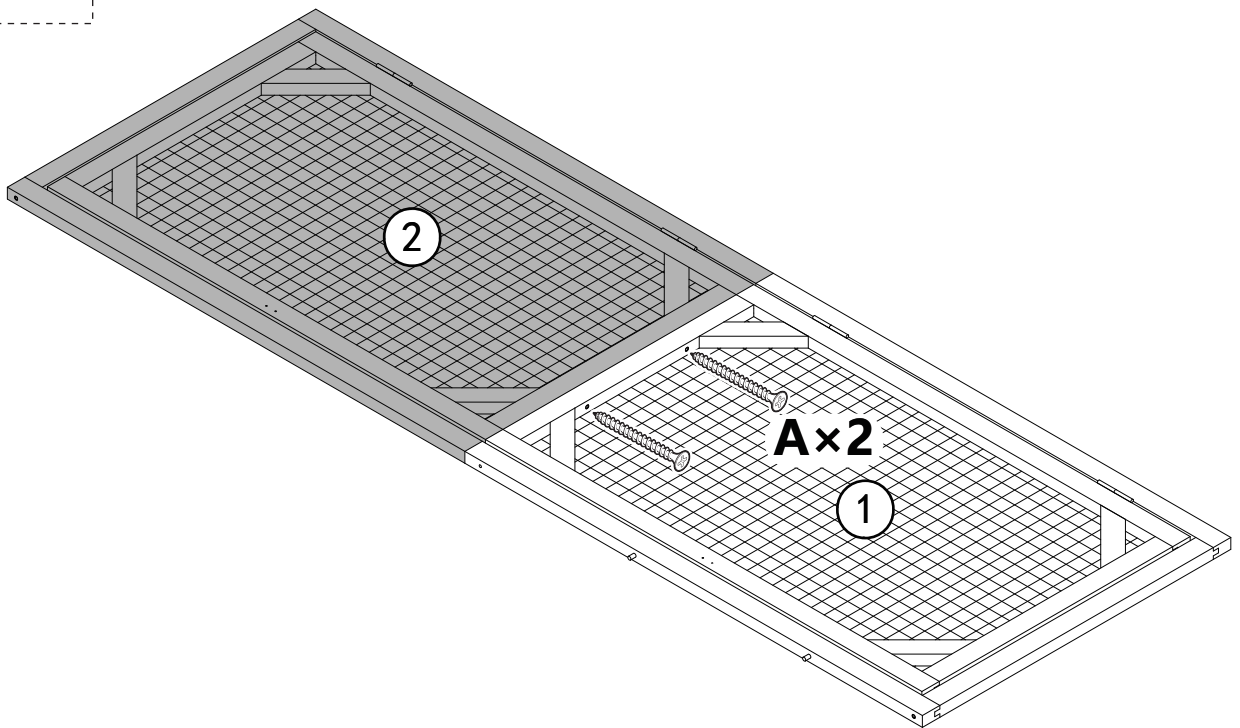

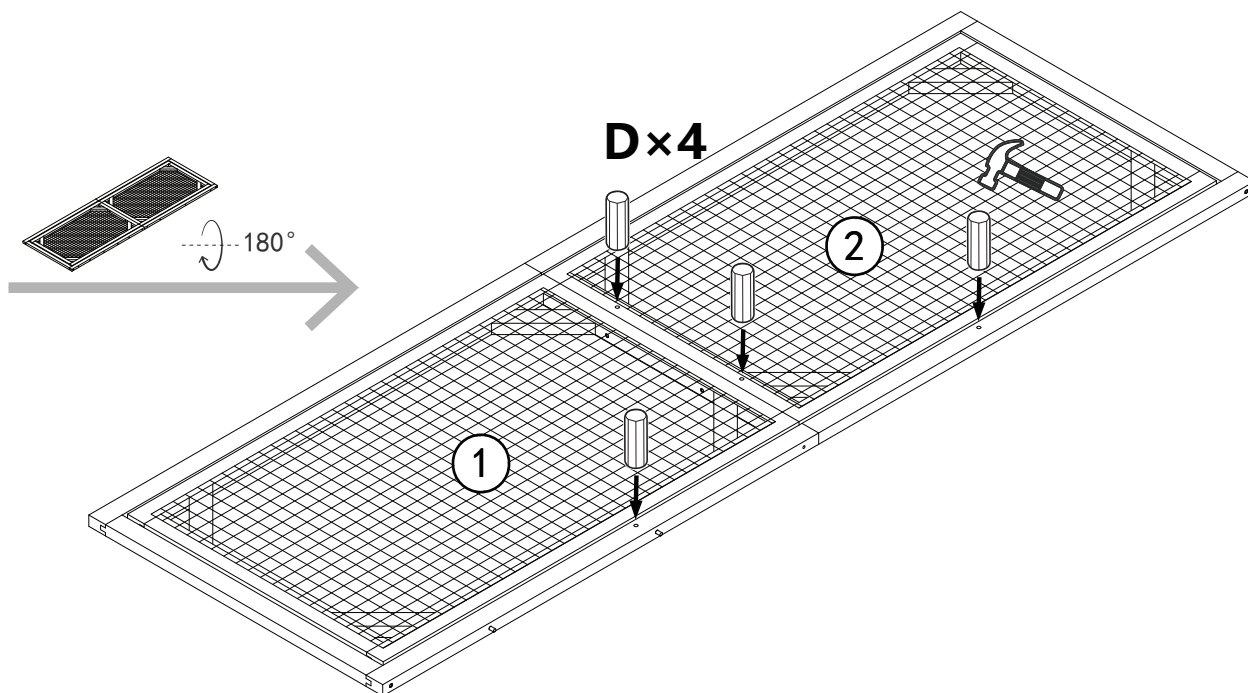
D x 4**G x 6**

3.0*30

H x 4

3.0*25

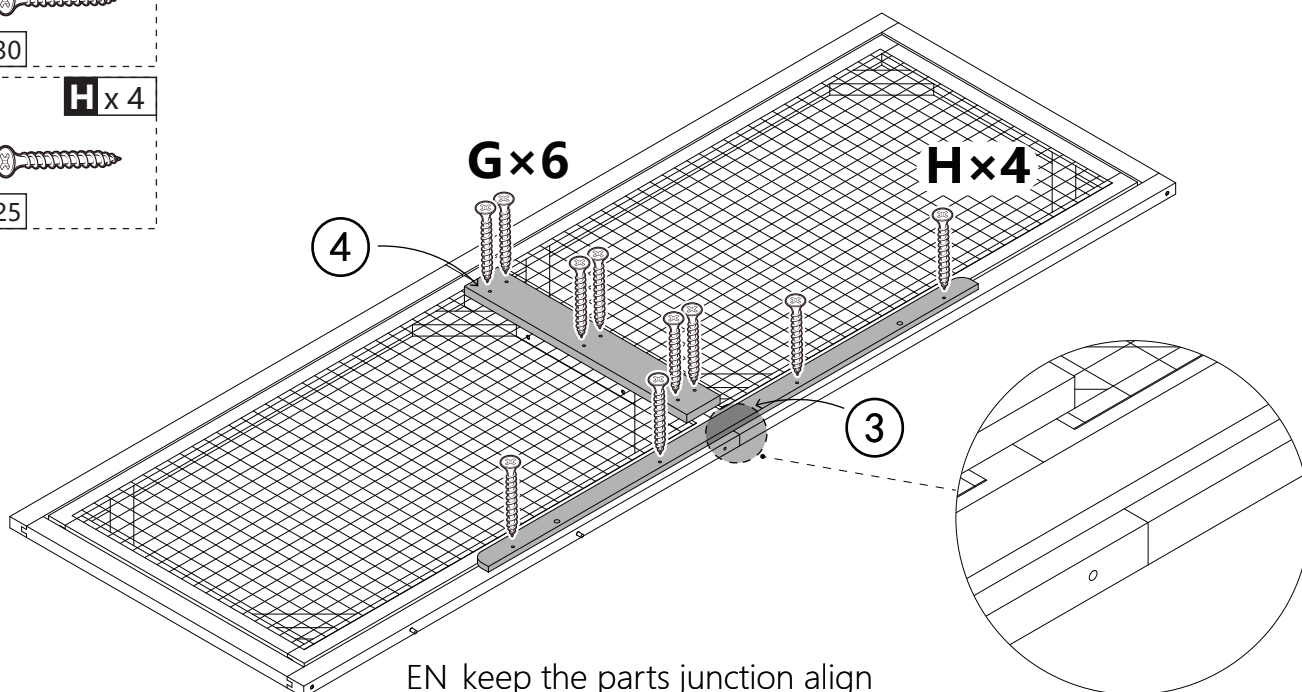

EN_ keep the parts junction align
 FR_ maintenir l'alignement des jonctions des pièces
 ES_ mantener alineadas las uniones de las piezas
 PT_ mantenha as peças alinhadas
 DE_ Die Teileausrichtung beibehalten
 IT_ Mantenere allineati i punti di giunzione delle parti

A x16



3.5*60

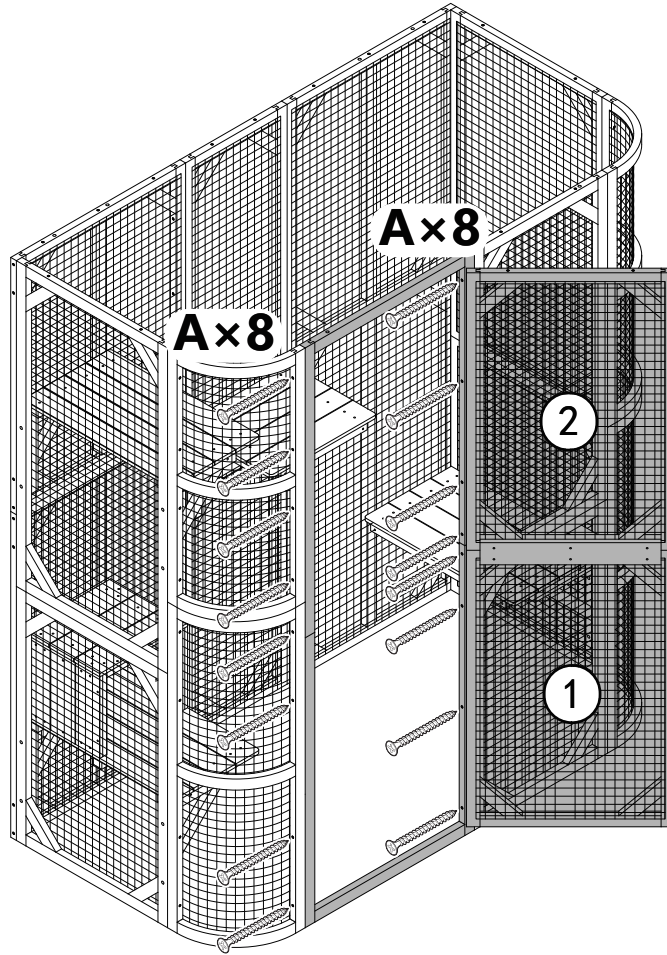

D x6

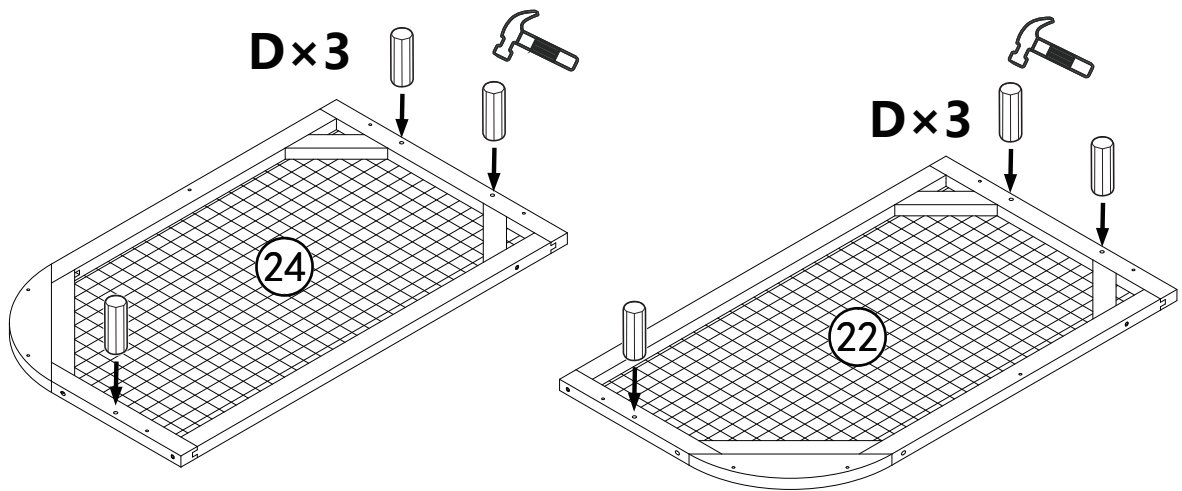

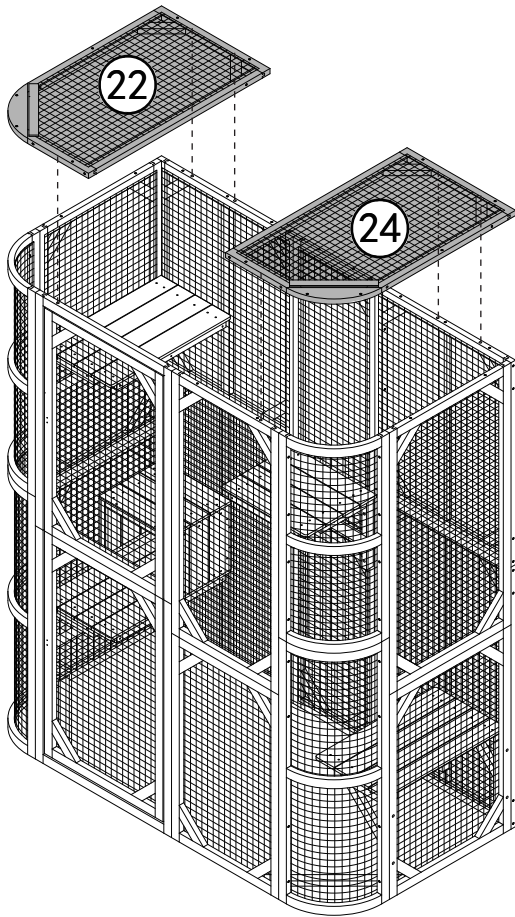

EN_ make sure the metal mesh side of parts 22.24 up, and the dowels must align with the holes.

FR_ Assurez-vous que le côté en treillis métallique des pièces 22.24 est vers le haut et que les chevilles sont alignées avec les trous.

ES_ Asegúrese de que el lado de malla metálica de las piezas 22.24 quede hacia arriba y que las clavijas estén alineadas con los orificios.

PT_ Certifique-se de que o lado da malha metálica das peças 22.24 esteja voltado para cima e que os pinos estejam alinhados com os orifícios.

DE_ Stellen Sie sicher, dass die Metallgitterseite der Teile 22.24 nach oben zeigt und die Dübel mit den Löchern übereinstimmen.

IT_ assicurarsi che il lato in rete metallica delle parti 22.24 sia rivolto verso l'alto e che i tasselli siano allineati con i fori.

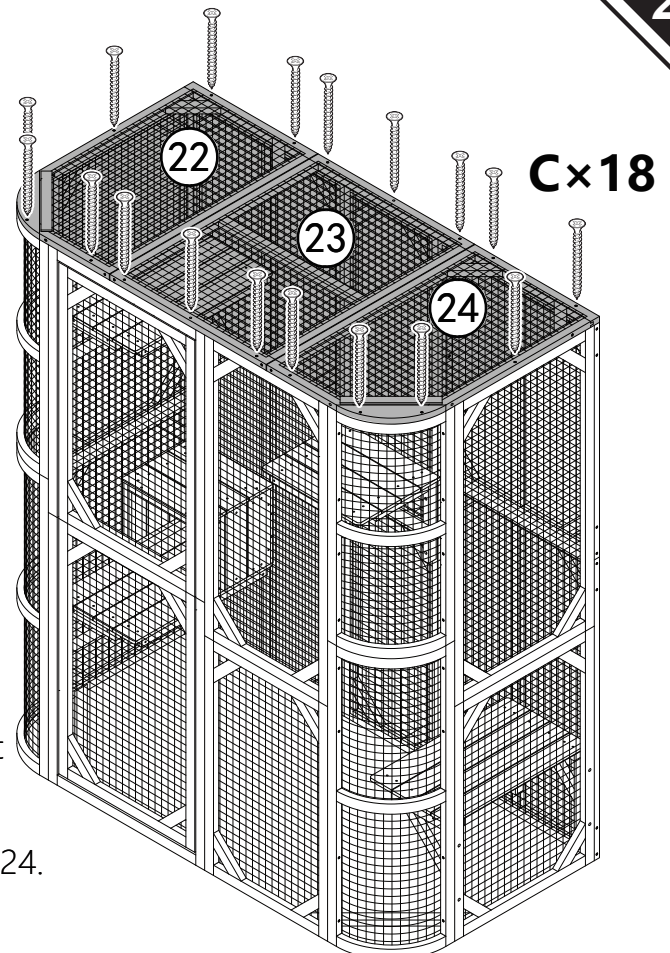
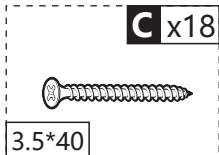

EN_ The front and rear of Part 23 shall be aligned flush with Parts 22 and 24

FR_ L'avant et l'arrière de la partie 23 doivent être alignés au ras des parties 22 et 24.

ES_ La parte delantera y trasera de la pieza 23 deben estar alineadas a ras con las piezas 22 y 24.

PT_ A parte frontal e traseira da Peça 23 devem estar alinhadas com as Peças 22 e 24.

DE_ Die Vorder- und Rückseite von Teil 23 muss bündig mit den Teilen 22 und 24 ausgerichtet sein.

IT_ La parte anteriore e posteriore della Parte 23 devono essere allineate a filo con le Parti 22 e 24.

C x 4



3.5*40

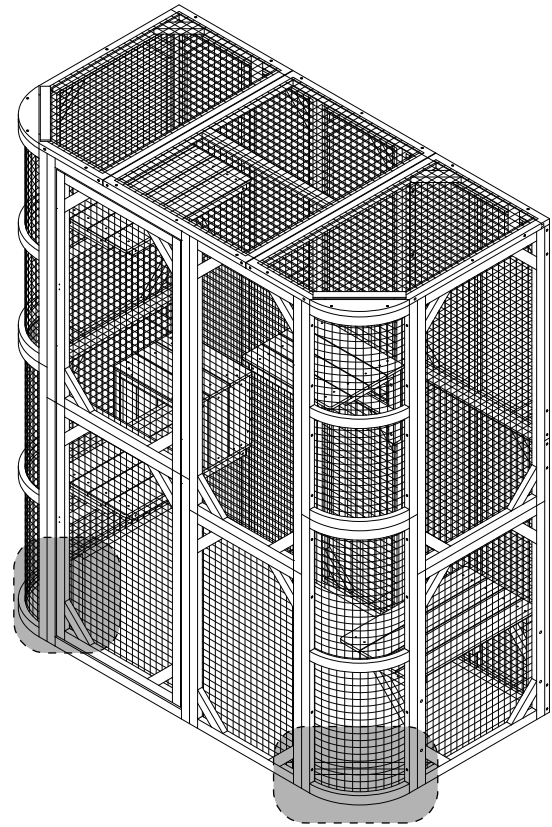
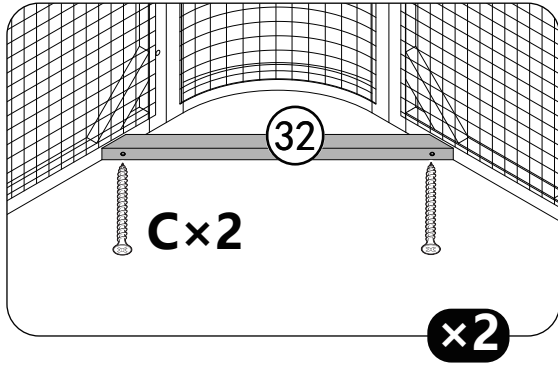

I x 8



3.5*16

K x 2

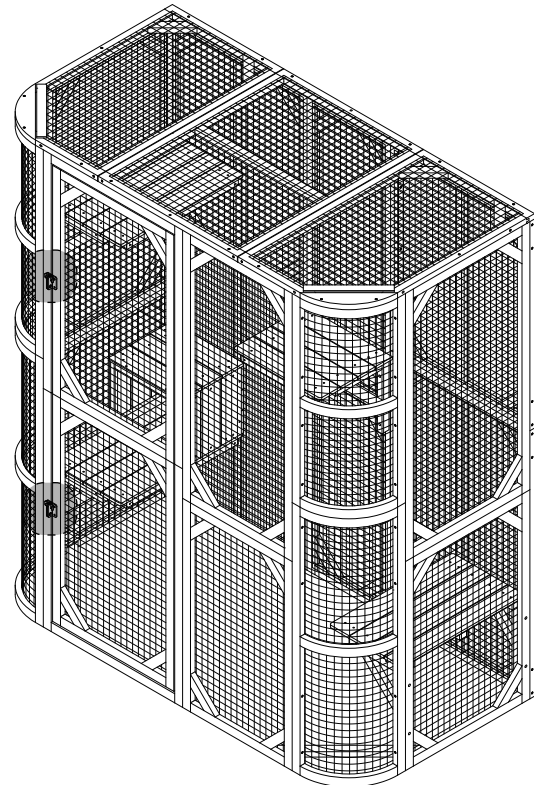
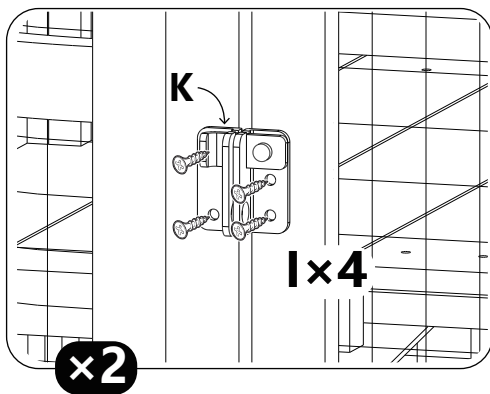

I x 8



3.5*16

L x 4



M x 4

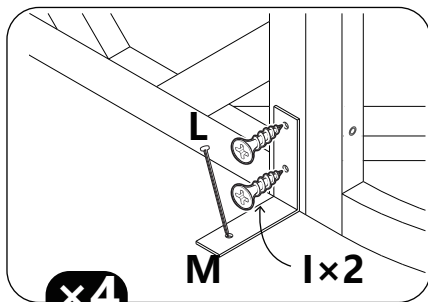
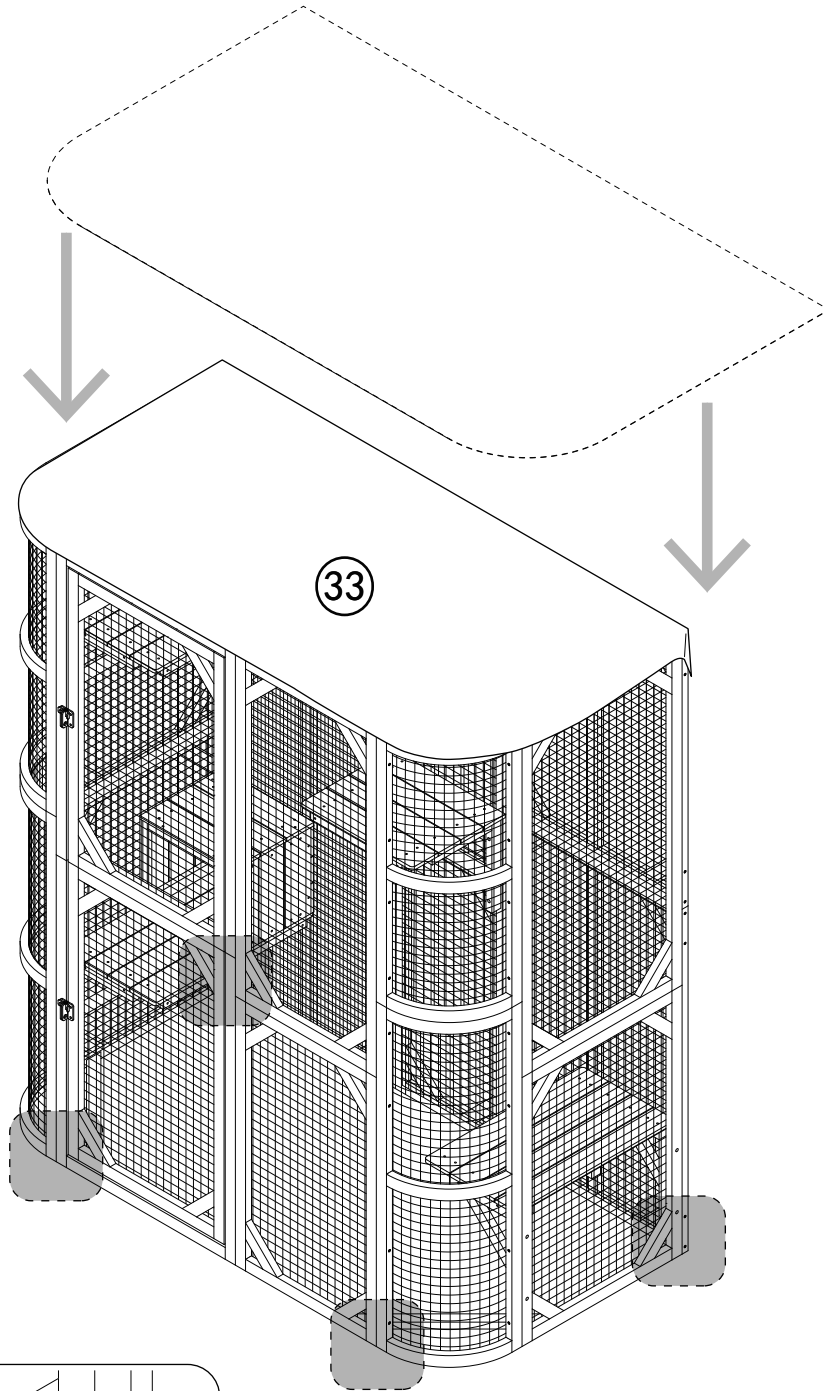
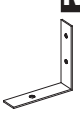

If you have any questions, please contact our customer care center, Our contact details are below:

US

 001-877-644-9366

 customerservice@aosom.com

Imported by Aosom LLC
27150 SW Kinsman Rd Wilsonville, OR 97070 USA
MADE IN CHINA

Wenn Sie Fragen haben, wenden Sie sich bitte an unser Kundendienstzentrum, Unsere Kontaktdaten stehen unten:

DE

 +49 40 87408465

 service@aosom.de

ADRESSE DES IMPORTEURE/Hersteller/REP:
MH Handel GmbH
Wendenstraße 309
D-20537 Hamburg
Germany
IN CHINA HERGESTELLT

If you have any questions, please contact our customer care center, Our contact details are below:

CA

 416-792-6088

 customerservice@aosom.ca

Imported by Aosom Canada Inc.
7270 Woodbine Avenue, Unit 307, Markham,
Ontario Canada L3R 4B9
MADE IN CHINA

Si vous avez la moindre question, veuillez contacter notre centre d'assistance à la clientèle, Nos coordonnées sont les suivantes:

 416-792-6088

 customerservice@aosom.ca

Importé par Aosom Canada Inc.
7270 Woodbine Avenue, unité 307,
Markham, Ontario Canada L3R 4B9
FABRIQUÉ EN CHINE

In caso di dubbio, si prega di contattare il nostro centro assistenza clienti, I nostri dettagli di contatto sono di seguito:

IT

 0039-0249471447

 clienti@aosom.it

IMPORTATO DA/Produttore/REP:
AOSOM Italy srl
Centro Direzionale Milanofiori
Strada 1 Palazzo F1
20057 Assago (MI)
P.I.: 08567220960
FATTO IN CINA

Si tiene alguna pregunta, comuníquese con nuestro Centro de Atención al Cliente, Nuestros datos de contacto son los siguientes:

ES

 0034-931294512

 atencioncliente@aosom.es

IMPORTADOR/Fabricante/REP:
SPANISH AOSOM, S.L.
C/ROC GROS, N°15.08550, ELS HOSTALETES DE
BALENYÀ, SPAIN.
B66295775
HECHO EN CHINA

If you have any questions, please contact our customer care center, Our contact details are below:

UK

 0044-800-240-4004

 enquiries@mhstar.co.uk

IMPORTER ADDRESS:
MH STAR UK LTD
Unit 27, Perivale Park,
Horsenden lane South
Perivale, UB6 7RH
MADE IN CHINA

Se tiver alguma dúvida, por favor contacte o nosso Centro de Atendimento ao Cliente, Os nossos dados de contacto são os seguintes:

 0034-931294512

 info@aosom.pt.

IMPORTADOR/Fabricante/REP:
SPANISH AOSOM, S.L
C.ROC GROS N.15, 08550. ELS HOSTALETES DE
BALENYÀ
FEITO NA CHINA

Si vous avez la moindre question, veuillez contacter notre centre d'assistance à la clientèle, Nos coordonnées sont les suivantes:

FR

 0033-1-84166106

 aosom@mhfrance.fr

Importé par/Fabricant/REP:
MH FRANCE
2 Rue Maurice Hartmann
92130 Issy Les Moulineaux
France
FABRIQUÉ EN CHINE



FR

**DONNEZ
OU
RECYCLEZ**



OU



OU



ASSOCIATION

LIVRAISON

DÉCHÈTERIE

Adresses sur quefairedemesdechets.fr