

These instructions are for the Candeo RD1 (sku: C-ZB-RD1) and RD1-Pro (sku: C-ZB-RD1P) Zigbee rotary dimming modules, and the supporting companion dimmer C-RD1C.

The Candeo C-RD1C is a companion dimmer to be used only with the Candeo RD1 or Candeo RD1-Pro as part of a 2-way lighting circuit.



Candeo RD1
C-ZB-RD1
Zigbee Rotary Smart Switch



Candeo RD1-Pro
C-ZB-RD1P
Zigbee Rotary Smart Switch



Candeo RD1-Companion
C-RD1C
Companion Dimmer Switch



Works With
HOME ASSISTANT

Works With
SMARTTHINGS

Works With
HUBITAT

Works With
ZIGBEE2MQTT

Features (RD1 and RD1-Pro)

- **Zigbee 3.0** rotary dimmer with advanced smart home integration
- **True 2-way rotary dimming** when paired with C-RD1C companion dimmer
- **Energy monitoring** - voltage, current, power consumption and energy usage tracking
- **Compatible** with SmartThings, Hubitat, Home Assistant, ZHA and others
- **Voice control** via Alexa and Google Assistant (when connected to compatible hub)
- **Leading and trailing edge** dimming technology selection
- **No neutral wire required** for most installations
- **Minimum and Maximum brightness settings** to set the perfect dimming range
- **Compact design** fits standard UK and EU back boxes

RD1-Pro only

- **Multi-mode functionality by decoupling the action of the knob from the circuit.**
- **Dimmer mode** – (as per RD1)
- **Remote mode** (also referred to as Smart Bulb mode)
 - Decouples the action of the rotary knob from the wired circuit attached to allow control of smart bulbs, and other smart home devices
 - Install anywhere without light circuit attached, using Candeo LED bypass
- **Dual Purpose mode**
 - Combines Dimmer mode and Remote mode
 - Decouples the action of the rotary knob from the wired circuit attached to allow control of smart bulbs, and other smart home devices
 - Installed on a lighting circuit, gives you smart control of the wired lighting circuit

Model Differences

Feature	Candeco RD1	Candeco RD1-Pro
Product SKU	C-ZB-RD1	C-ZB-RD1P
Dimmer Mode	✓	✓
Remote/Smart Bulb Mode	✗	✓
Dual Purpose Mode	✗	✓
Energy Monitoring	✓	✓
2-way Rotary Support with C-RD1C	✓	✓

Specifications

Input Voltage	220V-240V AC ~ 50/60Hz
Power Load	5-250W LED (Trailing Edge) 5-100W LED (Leading Edge)
Minimum Load	5W per lamp
Dimmer Control	AC Phase Cut (Leading/Trailing Edge)
Radio Frequency (C-ZB-RD1 and C-ZB-RD1P)	2405-2480MHz Zigbee 3.0
Power	9.75dBm eirp
Dimensions	84mm x 84mm x 37mm
Temperature Range	-5°C to +40°C
Humidity	10~95% RH

Safety Warnings

- **Turn Off Mains Power** before installing the device
- Do not expose the device to moisture or liquids
- Do not attempt to open the product to examine or repair
- Installation must be carried out by a qualified electrician
- Ensure minimum 5W total load for optimal operation
- Use only with high quality dimmable LED bulbs or halogen lamps
- This product is designed for indoor use only

Important Notes:

- **Only ONE RD1 or RD1-Pro** per circuit - pair with C-RD1C companion for 2-way
- **Companion dimmer C-RD1C** provides true rotary dimming at the secondary location.
- **Up to 2 x C-RD1C** devices can be installed on the circuit, for a total of 3-way lighting.
- Only **Candeco companion dimmers** support 2-way rotary control. **Other dimming devices** will **NOT** work with the Candeco RD1 or RD1-Pro and will damage the device.
- Controls from the Companion dimmer may experience a short delay up to 0.4 seconds.

Installation & Wiring

Installation Steps when used with a lighting circuit

1. Turn off the power

- Disconnect electrical power at the main fuse or circuit breaker
- Verify no voltage is present in the wiring before proceeding
- Take extra precautions to avoid accidentally energizing during installation

2. Remove existing switch/dimmer

- Carefully disconnect existing wiring
- Note wire positions for reference, and be sure of the Live and Load wires.

3. Connect the RD1/RD1-Pro according to the diagrams below

Single-Way Installation (Most Common)

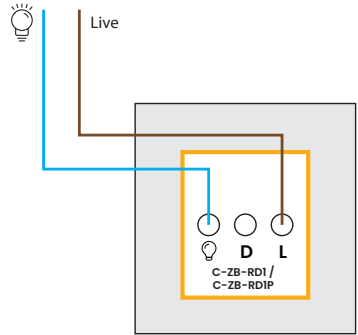

Figure 1

2-Way Installation with C-RD1C Companion

You will most likely find that your existing 2-way lighting is wired as per 1 of the following configurations:

The Candeco RD1-Pro/RD1 and the RD1C need to be wired as follows for a 2-way installation:

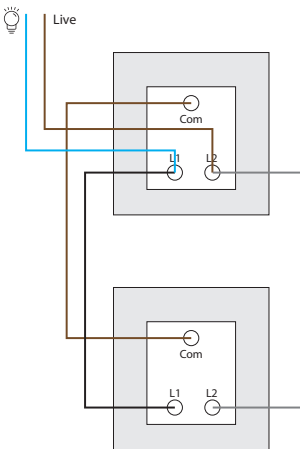

Figure 2a

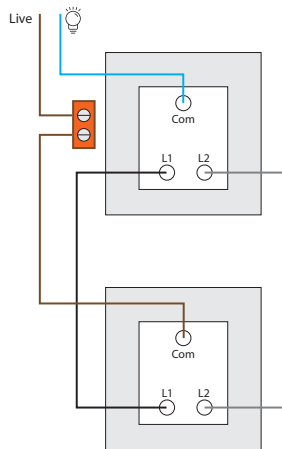

Figure 2b

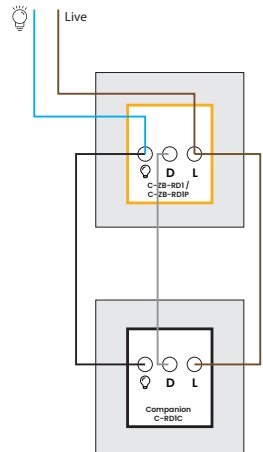

Figure 3

Physical Installation

- Fits standard 35mm UK back boxes (47mm depth recommended)
- Ensure adequate space behind faceplate for device depth
- LED status indicator visible through small aperture when installed

4. Restore power and proceed

RD1-Pro Notes:

If you are intending to use the RD1-Pro in Remote Mode (with either smart bulbs or a bypass load), it is advised to:

1. Initially wire the device to a standard bulb / lighting circuit
2. Set the device in Remote mode.
3. Remove the device from your circuit, and re-wire to your intended final circuit destination as per:
Figure 1 if you are using a circuit including smart bulbs or
Figure 4 if you are using a bypass as an alternative load.

Important Notes:

If you do wire directly to the circuit with smart bulbs or a bypass before completing the factory reset and pairing, be extra careful not to adjust the rotation of the rotary knob in between power restore and setting the device in Remote mode.

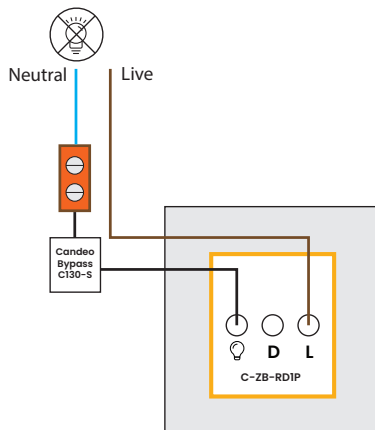

Figure 4

5. Factory Reset On First Use

- **Button sequence:** 4 short presses + long 5th press
- **LED confirmation:** Red LED stays solid for 3 seconds
- All previous network settings will be cleared
- RD1-Pro: Mode will be reset to Dimmer Mode.

Mode Setting and Pairing to your Hub

RD1-Pro only:

Please refer to the detailed Mode comparison chart in Appendix 1 of the instructions.

Choose the mode in which you wish to operate your device, using the commands given below:

Mode	Command	LED Feedback
Dimmer	3 short presses	Red LED flashes 6 times
Remote Mode (smart bulb mode)	4 short presses	Green LED flashes 6 times
Dual Purpose Mode	5 short presses	Blue LED flashes 6 times

Pairing to Your Zigbee Hub

1. Set hub to pairing mode

- Open your hub's app (SmartThings, Hubitat, Home Assistant, etc.)
- Select "Add Device" or "Join Device"
- Choose zigbee device category

2. Activate pairing on RD1/RD1-Pro

- **Button sequence:** 2 short presses + long 3rd press
- **LED confirmation:** Green and blue LEDs flash simultaneously
- Pairing mode lasts 3 minutes

3. Complete pairing

- Hub should discover the device within 30 seconds
- Device will appear as "Candee RD1" or "Candee RD1-Pro"
- LED will show solid green briefly when successfully paired

Hub-Specific Notes

SmartThings & Hubitat:

- Install Candeo device drivers for full functionality
- Drivers available at candeo.io/support
- Enables energy monitoring and advanced features

Zigbee2MQTT:

- Fully supported
- Full feature access including button events
- Energy monitoring data available via MQTT

Home Assistant (ZHA):

- Device will be auto-discovered with full support
- All features available immediately
- Energy monitoring appears as sensor entities

Dimmer Mode - Configuration

Applies To: RD1 (always) and RD1-Pro (when in Dimmer Mode)

Brightness Range Adjustment

Set custom minimum and maximum brightness levels for optimal performance with your specific bulbs.

Setting Minimum Brightness

1. **Start adjustment:** 5 short presses + long 6th press
2. **LED confirmation:** LED flashes green 2 times
3. **Adjust brightness:** Turn rotary knob to desired minimum level
4. **Save setting:** 2 short presses
5. **Confirmation:** LED stays solid green for 3 seconds

Recommended minimum: Lowest level where bulbs glow dimly without flickering

Setting Maximum Brightness

1. **Start adjustment:** 6 short presses + long 7th press
2. **LED confirmation:** LED flashes green 2 times
3. **Adjust brightness:** Turn rotary knob to desired maximum level
4. **Save setting:** 2 short presses
5. **Confirmation:** LED stays solid green for 3 seconds

Recommended maximum: Usually 100%, or lower if you prefer reduced peak brightness, or experience flickering at maximum brightness.

Dimming Technology Selection

Choose between leading edge and trailing edge dimming for optimal bulb compatibility.

Switch to Trailing Edge (Default - recommended for LEDs)

- **Button sequence:** 3 short presses + long 4th press
- **LED confirmation:** LED stays solid red and green for 3 seconds
- **Best for:** Most LED bulbs, CFL bulbs

Switch to Leading Edge (For specific compatibility)

- **Button sequence:** 3 short presses + long 4th press (toggles between modes)
- **LED confirmation:** LED flashes red and green 2 times
- **Best for:** Some halogen bulbs, older dimmable LEDs

Energy Monitoring

Access real-time and historical energy data through your hub:

Available measurements:

- **Voltage (V)** - Mains supply voltage
- **Current (A)** - Load current draw
- **Power (W)** - Instantaneous power consumption
- **Energy (kWh)** - Cumulative energy usage

Advanced Features & Zigbee Options

(RD1-Pro) Switching Between Modes After Setup

You cannot change modes after pairing. You will need to start the pairing process again:

1. Remove device from Zigbee network (see Page 7)
2. Factory reset device (4 short + long 5th press)
3. Select new mode (3/4/5 short presses for Dim/Remote/Dual Purpose)
4. Power Cycle your smart hub to clear cache
5. Re-pair to zigbee network
6. Reconfigure automations as needed

Note: Mode changes require complete re-setup and reconfiguration of automations.

TouchLink Pairing

Connect directly to TouchLink-compatible remotes without a hub.

Activate TouchLink

1. **Button sequence:** 8 short presses + long 9th press
2. **LED confirmation:** LED flashes green and blue
3. **Usage:** Bring remote within 10cm and activate its TouchLink mode
4. **LED confirmation:** LED stays solid red, green, and blue for 3 seconds
5. **Duration:** 3 minutes timeout

TouchLink Capabilities

- **Without network:** Each device links with 1 remote maximum
- **With network:** Each device links with up to 30 remotes maximum
- **Control:** Linked remotes can directly control the device
- **Range:** Normal Zigbee range once paired

Find and Bind

Automatically discover and bind to compatible devices on the same network.

Activate Find and Bind

- **Button sequence:** 9 short presses + long 10th press
- **LED confirmation:** LED flashes blue
- **Requirements:** Both devices must be on same Zigbee network
- **Usage:** Automatic binding with compatible remotes and sensors

Remove from Zigbee Network

- **Button sequence:** 7 short presses + long 8th press
- **LED confirmation:** Device specific indication
- **Hub action:** Also remove from hub app/interface
- **Reset required:** Factory reset recommended after removal

Factory Reset

- **Button sequence:** 4 short presses + long 5th press
- **LED confirmation:** Red LED stays solid for 3 seconds
- All previous network settings will be cleared
- RD1-Pro: Mode will be reset to Dimmer Mode.

Appendix 1: Mode Selection (RD1-Pro) & Button Operations

This section relates to the **RD1-Pro** model only.

The RD1-Pro offers three operating modes. **Please read carefully to understand the 3 modes available.**

IMPORTANT: You must select your desired mode **BEFORE** pairing the device to your Zigbee network. If you wish to change modes after pairing, you will need to factory reset the device, and start the pairing process again.

Feature	Dimmer Mode (Default)	Remote/Smart Bulb Mode	Dual Purpose Mode
Firmware ID	C-ZB-RD1P-DIM	C-ZB-RD1P-REM	C-ZB-RD1P-DPM
Use Case	Smart control of traditional (non-smart) lighting circuit containing dimmable lights	Use as smart rotary remote for smart bulbs or other smart home devices. Keeps the wired circuit constantly powered (maintaining smart bulb connectivity).	Combines Dimming mode and Remote mode. Rotary knob is used as smart rotary remote for smart bulbs or other smart home devices. Hub independently controls wired lighting circuit
Rotary Control Knob	Controls brightness and on/off state of connected light circuit	Fully decoupled from circuit, sends smart commands to Zigbee hub.	Fully decoupled from circuit, sends smart commands to Zigbee hub
Wiring	Connected to traditional lighting circuit with non-smart bulbs	Option 1: Wired to lighting circuit with smart bulbs (constantly powered) Option 2: Wired to mains circuit using LED bypass as load	Connected to traditional lighting circuit with non-smart bulbs. (RD1-Pro doesn't physically switch circuit).
Bypass Requirements	Optional	<ul style="list-style-type: none"> Optional when wired to smart bulbs circuit Essential if wired to mains circuit without smart bulbs 	Optional
Operation	Standard dimmer operation	<ul style="list-style-type: none"> Wired circuit stays permanently energized Rotary knob sends Zigbee commands to hub Physical button presses trigger smart events Smart bulbs are controllable via hub automations. 	<ul style="list-style-type: none"> Rotary knob sends Zigbee commands to hub (same as REM mode) Physical button presses trigger smart events Smart bulbs are controllable via hub automations. + Hub can independently switch/dim wired circuit
Zigbee Endpoints	1: Endpoint 01 – Dimmable Light	1: Endpoint 02 – Remote Control	2: Endpoint 01 – Dimmable Light Endpoint 02 – Remote Control
Smart System Behaviour	Shows as a light with dimming capabilities	Identified as a remote; doesn't control wired circuit directly	Two entities created: 1. Smart dimmable light 2. Remote control
Device to Smart System Relationship	Knob and Smart Device (light) are synchronized	Fully decoupled from circuit. Sends StepUp/StepDown, MoveUp/MoveDown, single press, double press, hold, and release events to smart home system.	Fully decoupled from circuit. Sends StepUp/StepDown, MoveUp/MoveDown, single press, double press, hold, and release events to smart home system.
Specific Use Cases	Traditional smart dimming	Smart bulb control, scene activation, alternative device control. E.g. Use automations to control brightness of smart bulbs, or white balance. Or create complex automations to control multiple devices.	<ul style="list-style-type: none"> Mixed lighting (smart bulbs + wired dimmable lights) Scene control (rotary for smart bulbs, hub for traditional lighting). E.g. Use automations to control brightness of smart bulbs, or white balance. Or create complex automations to control multiple devices. + Standard light setup
Button Sequence to Enter Mode	3 short presses	4 short presses	5 short presses
LED Confirmation	Red LED flashes 6 times	Green LED flashes 6 times	Blue LED flashes 6 times

Troubleshooting & Further Support

Important Notes:

- LED indicators appear only during button-based mode/setup actions (see setup reference).
- The RD1-Pro does not switch or interrupt power in DPM or REM mode; power must be managed by smart controls.
- Commands sent from the companion rotary dimmer can be delayed up to 0.4s.

Mode-Specific Troubleshooting

Dimmer Mode Issues

- **Flickering at low levels:** Increase minimum brightness setting or check bulb compatibility
- **Bulbs don't turn completely off:** Check the dimming mode of your lights, and ensure you have set the dimmer to the correct mode. Increase minimum brightness or consider using a bypass.
- **Dimming range too narrow:** Adjust both minimum and maximum brightness settings
- **Energy monitoring not appearing:** Install manufacturer drivers or check hub configuration

Common Issues

Device Won't Pair

- **Check range:** Move hub closer during pairing (within 10m)
- **Network capacity:** Verify hub hasn't reached device limit
- **Factory reset:** Complete reset and try pairing within 30 seconds
- **Hub compatibility:** Install manufacturer drivers for Smartthings and Hubitat. Please ensure that you are running the latest firmware and software on your smart hub platform.

Poor Performance After Installation

- **Insufficient load:** Ensure minimum 5W total load on circuit
- **Bulb compatibility:** Use high-quality dimmable LED bulbs
- **Wiring issues:** Verify correct terminal connections
- **Power supply:** Check mains voltage is within 100-240V range

2-Way Setup

- **Device limits:** Only one RD1/RD1-Pro per circuit with up to 2 RD1C devices.

Technical Support

Please visit our support site and knowledge

base at: www.candeo.io/support

Here you will find answers to common questions, and contact us for further information.

Warranty Information

- **Coverage:** 2 years from purchase date
- **Includes:** Manufacturing defects and electronic failures
- **Excludes:** Installation damage, misuse, normal wear
- **Claim process:** Contact support with proof of purchase

Compliance Information

Hereby, Candeo Smart Ltd declares that the radio equipment type used in the following devices is in compliance with Directive 2014/53/EU and S.I.2017/1206:

C-ZB-RD1, C-ZB-RD1P, C-RD1C and each variant including:
C-ZB-RD1P-W1G, C-ZB-RD1P-W2G, C-ZB-RD1P-MB1G,
C-ZB-RD1P-MB2G, C-ZB-RD1P-BC1G, C-ZB-RD1P-BC2G,
C-ZB-RD1-W1G, C-ZB-RD1-W2G, C-RD1C-W1G

The full text of the EU declaration of conformity is available at the following internet address: www.candeo.io/support

Hereby, Candeo Smart Ltd declares that the radio equipment type is in compliance with S.I.2017/1206. The full text of the UK declaration of conformity is available at the following internet address: www.candeo.io/support

Candeo Smart Ltd
27 Old Gloucester Street,
London, United Kingdom
WC1N 3AX
www.candeo.io

EU Authorised Representative:
24hour Solutions B.V.
Van Nelleweg 1,
3044 BC Rotterdam,
The Netherlands
compliance@24hour-ar.com

Instructions version: v2025.8

