

# Avalla Air Fryers



A-171



A-175



A-177



A-195

Read this manual carefully before use and keep it for future reference. Failure to do so may result in injury, property damage and may void the warranty.



# Contents

02	Contents
03	First time set up: A-171, A-175, A-177 <ul style="list-style-type: none"><li>• General guidance</li></ul>
04	Parts guide: A-171
05	Using your A-171
06	Parts guide: A-175
07	Using your A-175
08	Parts guide: A-177
09	Using your A-177
10	Parts guide: A-195
11	First time set up: A-195
12	Display guide: A-195 Air Fryer Mode
13	Using your A-195 Air Fryer Mode
14	Display guide: A-195 Pressure Cooker Mode
15	Using your A-195 Pressure Cooker Mode
16	Cleaning and storage
16	Health and safety <ul style="list-style-type: none"><li>• Symbols from the unit and packaging</li><li>• The following must always be observed for safety</li></ul>
19	Disposal
19	Troubleshooting
19	Troubleshooting - A-195 Pressure Cooker
20	Specifications

# First time set up: A-171, A-175, A-177

Please familiarise yourself with the instructions and operation of your cooker before use.

Basic safety precautions should always be followed.

Remove all packaging and labels. Check vents are clear of debris.

Clean the cooking basket and tray with warm soapy water, use a non abrasive sponge or cloth. Wipe down the unit with a damp cloth. Dry everything thoroughly before use.

Place the crisping tray into the cooking basket and slide the basket into the unit

Place your air fryer on a solid, heat resistant surface. Ensure the unit is level and stable. Leave space behind and around the unit to allow hot air to vent safely.

We recommend running your air fryer empty at 200°C for 5 minutes to remove residue from manufacturing. You may notice a slight smell on first use, this is normal.

## General guidance

Please ensure all food is piping hot throughout before serving. Cooking times are a guide and may vary depending on quantity and personal preference, please refer to your recipes' instructions for more information.

Whilst cooking, you may want to periodically turn the food over to ensure food is evenly cooked.

Once cooking has finished, remove the cooking basket and place on a flat, heat resistant surface. Use a heat resistant utensil to remove food.

# Parts guide: A-171

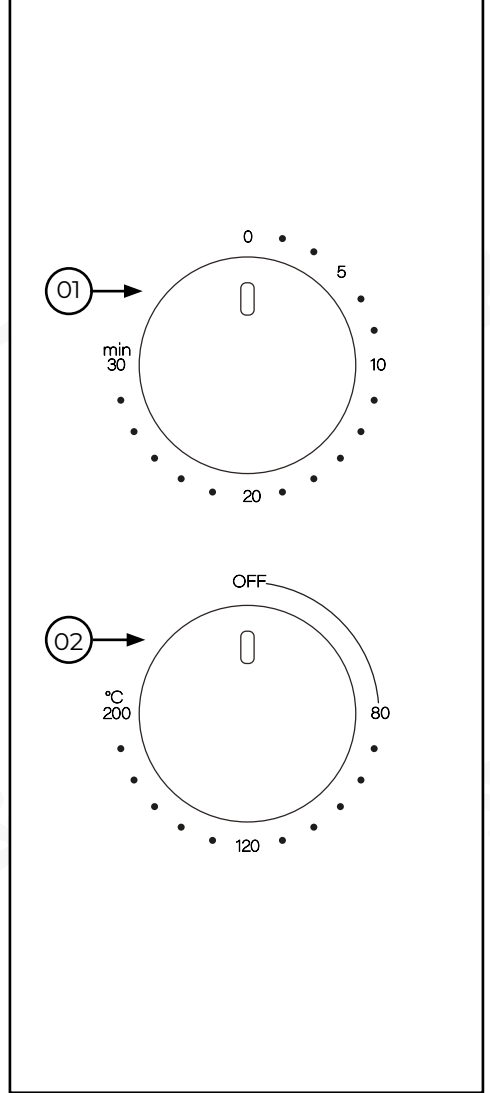
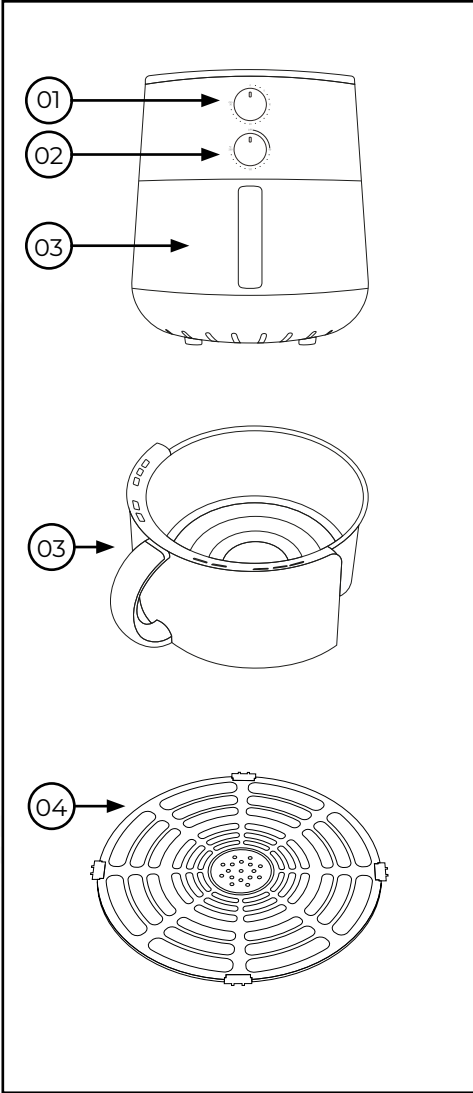

- 01. Time Control
- 02. Temperature Control

- 03. Cooking Basket
- 04. Tray

# Using your A-171

## Set

Select cooking time and temperature, the table below gives suggested cooking times and temperatures, adjust according to your recipe or preference.

Turn the 'Time control' clockwise to desired cooking time, then turn the 'Temperature control' clockwise to the desired cooking temperature.

## Start

Cooking will start when the temperature is selected.

## End

After cooking, the A-171 will ring and the fan will operate for 40 seconds to cool the air fryer down.

Food	Suggested cooking time (mins)	Suggested cooking temperature (°C)
Chips	15 -20	200
Bacon	12 -18	180
Pizza	15 - 20	170
Cake	12 - 18	180
Poultry	12 - 18	200
Meat	12 - 15	180
Fish	14 - 20	180

# Parts guide: A-175

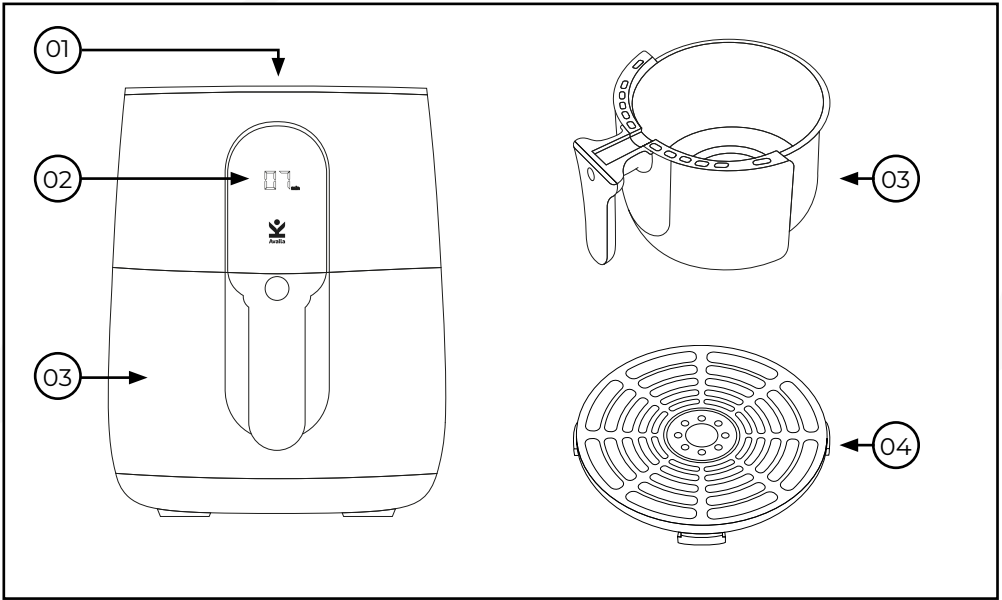

01. Control panel (top of unit)  
02. Front display

03. Cooking Basket  
04. Tray

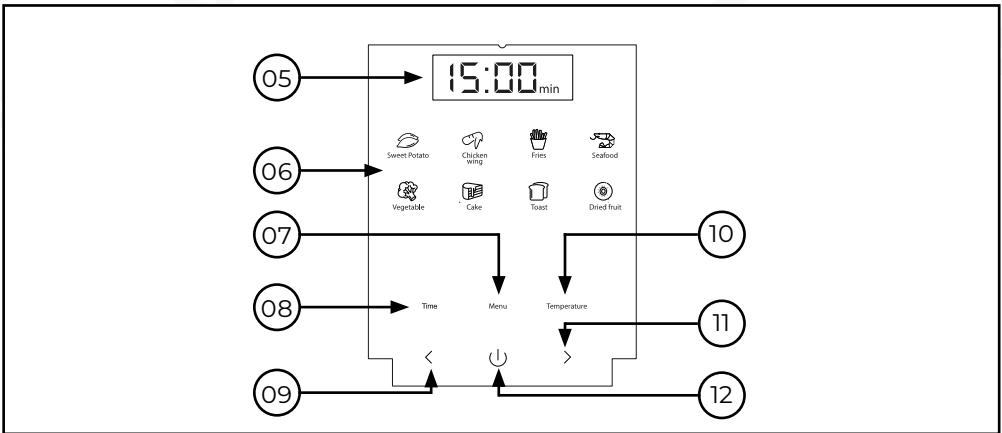

05. Display  
06. Cooking program  
07. Menu  
08. Time

09. <  
10. Temperature  
11. Power  
12. >

# Using your A-175

Press 'Power' to enter standby mode. The control panel and display will illuminate.

## Set - manual cooking

Press 'Time', the 'Display' will show cooking time in minutes and 'min'. Adjust the time using '<' and '>'. Press 'Temperature', the 'Display' will show cooking temperature and '°C'. Adjust the temperature using '<' and '>'.

## Set - cooking programs

Press 'Menu' to cycle through the programs, the selected program will illuminate and default cooking time is displayed, you can adjust the cooking time using '<' and '>'. Press 'Temperature' and the default cooking temperature is displayed, you can adjust the cooking temperature using '<' and '>'.

## Start - cooking

Press 'Power' and cooking will start. The 'Display' will show cooking temperature and the 'Front display' will show the remaining time. You can adjust the time or temperature during cooking and you can cancel cooking at anytime by pressing 'Power'.

## End

After cooking, the 'Display' will show 'End'. The fan will continue to operate to cool the air fryer down.

Food	Default cooking time (mins)	Default cooking temperature (°C)
Sweet Potato	30	200
Chicken Wings	20	200
Fries	20	200
Seafood	10	180
Vegetables	10	200
Cake	15	180
Toast	5	160
Dried Fruit	60	150

# Parts guide: A-177

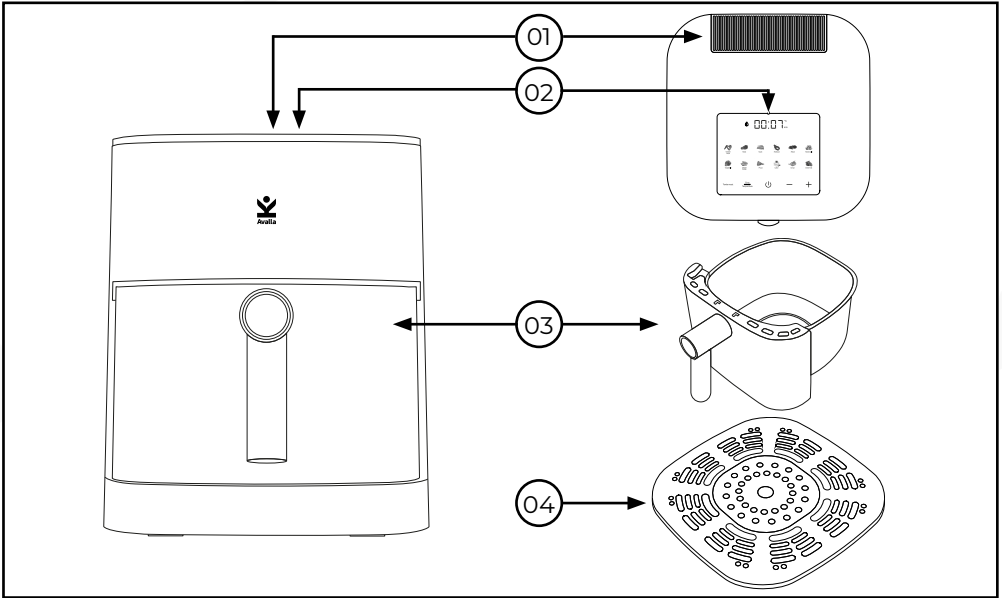

- 01. Water tank (top of unit)
- 02. Control panel (top of unit)

- 03. Cooking basket
- 04. Tray

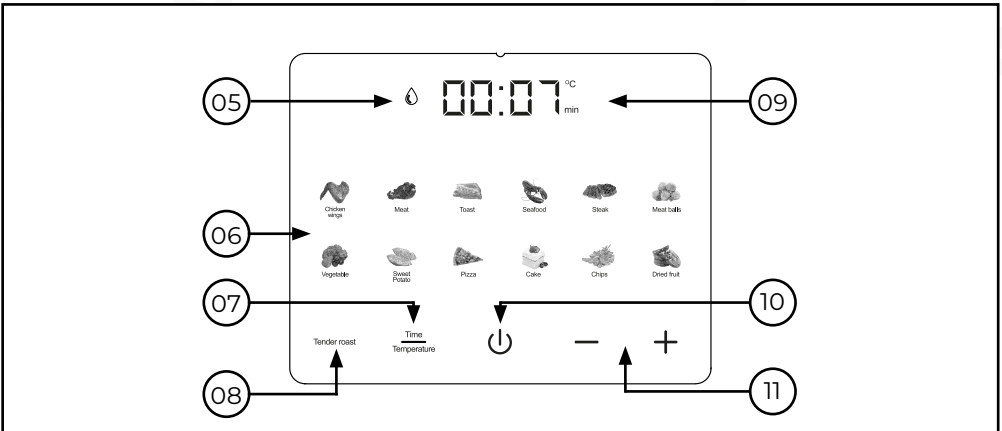

- 05. Tender roast symbol
- 06. Cooking program
- 07. Tender roast
- 08. Time / Temperature

- 09. Display
- 10. Power
- 11. - / +

# Using your A-177

Press 'Power' to enter standby mode. The 'Control panel' and 'Display' will illuminate.

## Set - manual cooking

Press 'Time', the 'Display' will show cooking time in minutes and 'min' will illuminate. Adjust the time using '- / +'. Press 'Time / Temperature', the 'Display' will show cooking temperature and '°C' will illuminate. Adjust the temperature using '- / +'.

## Set - cooking programs

Choose your desired program by pressing it, the selected program will illuminate and default cooking time is displayed, you can adjust the cooking time using '- / +'. Press 'Time/Temperature' and the default cooking temperature is displayed, you can adjust the cooking temperature using '- / +'.

Some modes offer a 'Tender roast' feature. In this mode water is automatically sprayed on the food to prevent it from drying out. When available the 'Tender roast symbol' will illuminate. To use this feature, fill the 'Water tank' with fresh water. Press 'Tender roast' to activate or deactivate this mode.

## Start - cooking

Press 'Power' and cooking will start. The 'Display' will show the remaining time. You can adjust the time or temperature during cooking and you can cancel cooking at anytime by pressing 'Power'.

## End

After cooking, the 'Display' will show 'End'. The fan will continue to operate to cool the air fryer down.

Food	Default time (mins)	Default temperature (°C)	Food	Default time (mins)	Default temperature (°C)
Sweet Potato	30	200	Toast	5	200
Chicken Wings	20	200	Dried Fruit	60	100
Fries	20	200	Meat	15	200
Seafood	10	180	Steak	10	200
Vegetables	10	200	Meatballs	10	180
Cake	12	180	Pizza	20	170

# Parts guide: A-195

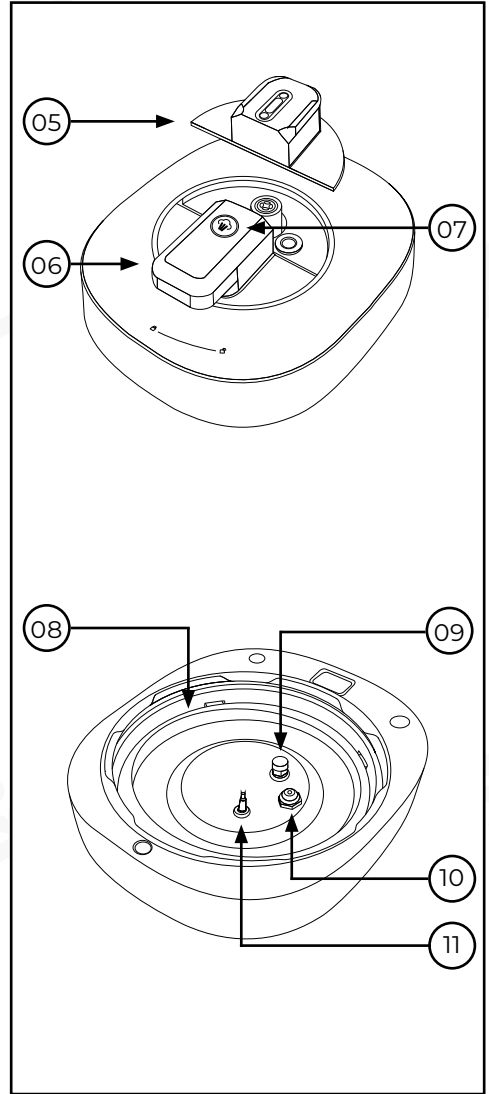
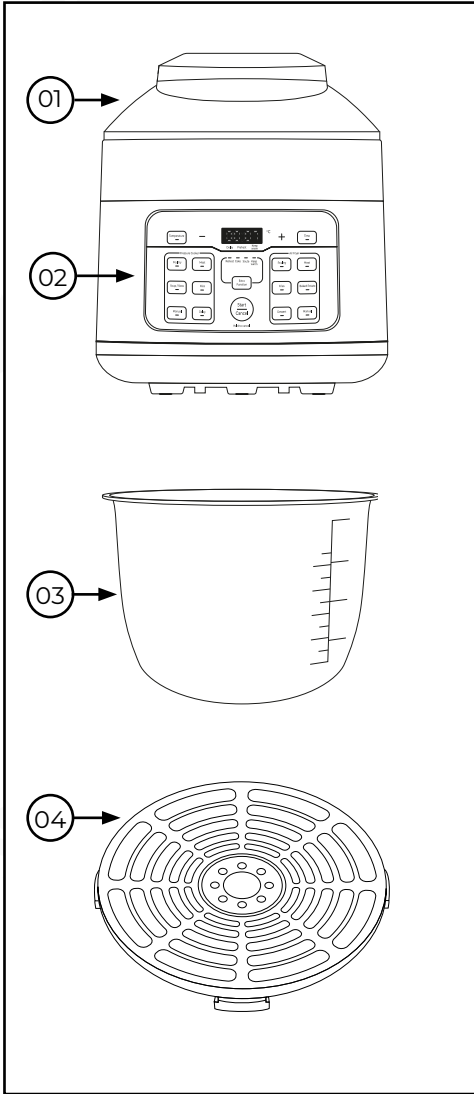

- 01. Air fryer lid
- 02. Control panel
- 03. Cooking pot
- 04. Tray
- 05. Valve cover
- 06. Handle

- 07. Pressure release
- 08. Silicone ring
- 09. Bleed pipe
- 10. Float valve
- 11. Temperature sensor

# First time set up: A-195

Please familiarise yourself with the instructions and operation of your multi cooker before use. Basic safety precautions should always be followed.

Remove all packaging and labels. Check vents are clear of debris. Wipe down the unit with a damp cloth.

Place your multi cooker on a solid, heat resistant surface. Ensure the unit is level and stable. Leave space behind and around the unit to allow hot air to vent safely.

## **Air Fryer Lid**

Clean the 'Cooking pot' and 'Tray' with warm soapy water, use a non abrasive sponge or cloth.

Place the 'Tray' inside the 'Cooking pot' and place the pot into the unit.

Plug the unit in. We recommend running your air fryer empty at 200°C for 5 mins to remove residue from manufacturing. You may notice a smell on first use, this is normal.

## **Pressure Cooker Lid**

Remove the 'Silicone ring' from the 'Pressure cooker lid'. Clean the 'Pressure cooker lid', 'Cooking pot', 'Silicone ring' in warm soapy water and then dry thoroughly.

Replace the 'Silicone ring', ensuring it is seated correctly. It can be placed either way. If the 'Silicone ring' is not properly seated the lid won't seal fully and the cooker won't be able to pressurise.

Ensure the 'Float valve' moves up and down freely and is clear of debris.

Replace the 'Pressure cooker lid', turn the 'Handle' clockwise until it locks in place. Make sure it's correctly fitted.

**Caution:** Only lift the 'Pressure cooker lid' by the 'Handle'. Do not lift from the removable 'Valve cover'.

# Display guide: A-195 Air Fryer Mode

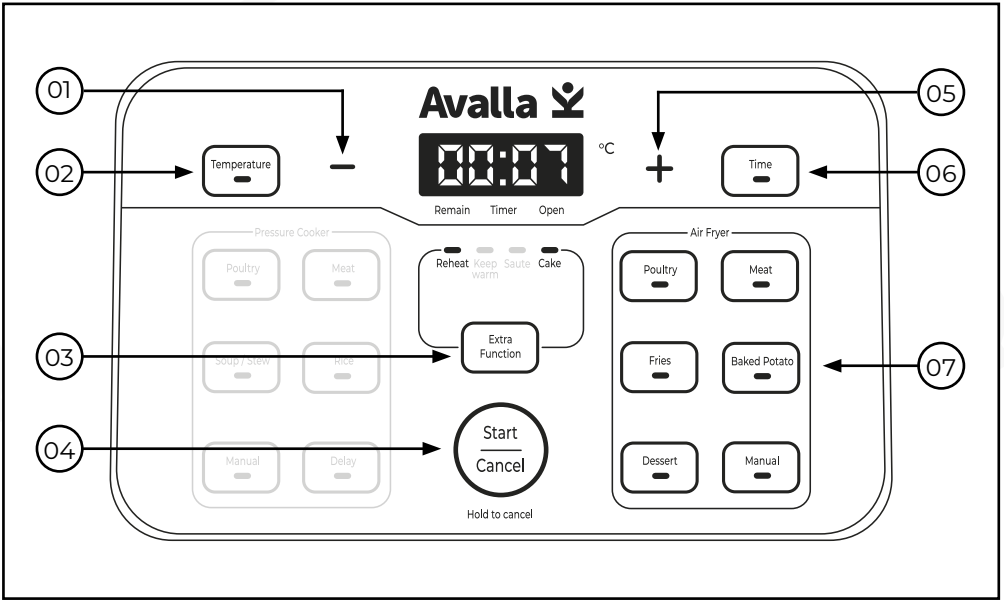

- 01. -
- 02. Temperature
- 03. Extra function
- 04. Start / Cancel

- 05. +
- 06. Time
- 07. Cooking program

## Default cooking times and temperatures

The table below shows the default cooking times and temperatures for each cooking program. These are a guide and can be adjusted using the '-' and '+' buttons.

Food	Default cooking time (mins)	Default cooking temperature (°C)
Poultry	20	180
Meat	20	180
Fries	17	180
Baked Potato	50	200
Dessert	20	135
Reheat	5	120
Cake	40	130

# Using your A-195 Air Fryer Mode

Place the 'Air fryer lid' on the unit, the available 'Cooking programs' will illuminate on the control panel.

## **Set - cooking programs**

Choose your desired 'Cooking program', the selected program will illuminate. The default cooking time will be shown. You can adjust cooking time using the '-' and '+' buttons. Press 'Temperature', the default cooking temperature will be shown, You can adjust the cooking temperature using the '-' and '+' buttons

## **Set - extra function**

Press 'Extra function' to cycle between 'Reheat' and 'Cake' functions, the selected program will illuminate. The default cooking time will be shown. You can adjust cooking time using the '-' and '+' buttons. Press 'Temperature', the default cooking temperature will be shown, You can adjust the cooking temperature using the '-' and '+' buttons.

## **Set - manual program cooking**

Press 'Manual' to set your own time and temperature. Use the '-' and '+' buttons to set the cooking time. Press 'Temperature' and use the '-' and '+' buttons to set cooking temperature

## **Start - cooking**

Press 'Start/Cancel' and cooking will start. The display will show the time remaining. You can adjust the time or temperature during cooking and you can cancel cooking at anytime by pressing 'Start/Cancel'.

## **End**

After cooking, if the temperature is above 150°C, the display will show 'Cool' and the fan will operate to cool the air fryer down.

# Display guide: A-195 Pressure Cooker Mode

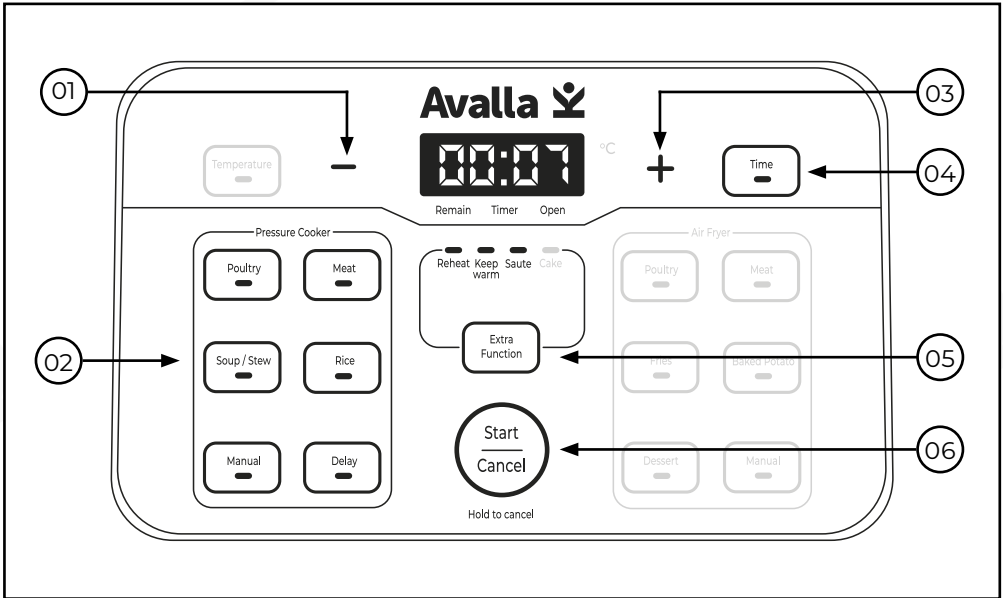

- 01. -
- 02. Cooking program
- 03. +

- 04. Time
- 05. Extra Function
- 06. Start / Cancel

## Default cooking times

The table below shows the default cooking times for each cooking program. These times are a guide and can be adjusted using the '-' and '+' buttons.

Function	Default cooking time (mins)
Poultry	30
Meat	35
Soup / Stew	38
Rice	20
Reheat	8
Sauté (Lid off)	20

**Note** - The times shown include preheat time. Preheat times vary depending on quantity of food being cooked and whether it is fresh or frozen.

# Using your A-195 Pressure Cooker Mode

Place the 'Pressure cooker lid' on the unit, turn the handle clockwise to lock the lid, the available 'Cooking programs' will illuminate on the control panel.

## Set - cooking programs

Choose your desired 'Cooking program', the selected program will illuminate. The default cooking time will be shown. You can adjust cooking time using the '-' and '+' buttons.

## Set - extra function

Press 'Extra function' to cycle between 'Reheat' and 'Keep Warm' functions, the selected program will illuminate. The default cooking time will be shown. You can adjust cooking time using the '-' and '+' buttons. 'Keep warm' will keep your food between 60°C and 80°C.

 Tip - Remove the lid to use the 'Sauté' function.

## Set - manual program cooking

Press 'Manual' to set your own time. Use the '-' and '+' buttons to set the cooking time.

## Start - cooking

Press 'Start / Cancel' to begin preheating, the display will cycle and preheating will start. Cooking will commence once temperature and pressure have reached operating levels.

## Start - delay

If you would like to delay the start of cooking, press the 'Delay' button, and then use the '-' and '+' buttons to select how long you would like before the cooking starts, between 2 and 24 hours.

## Keep warm

Once the cooking program has finished, the unit will de-pressurise. You can manually release the pressure with the 'Pressure release' button on the handle.

When the 'Float valve' has fallen, the lid will be unlocked, turn the 'Handle' anti-clockwise to open the lid. The unit will automatically change to keep warm mode.

**Caution:** Take care when manually releasing pressure as high temperature steam will be released. Risk of scolding. Use heat protection when handling the pressure cooker.

# Cleaning and storage

The unit should be cleaned thoroughly after every use.

- Unplug the unit from the wall outlet before cleaning.
- To clean the cooker base and the control panel, wipe them clean with a damp cloth.
- Clean the cooking basket/pot with water and mild soap, using a non abrasive sponge or cloth.
- The crisping tray can be cleaned in a dishwasher
- If food residue is stuck on the cooking basket, fill the pot with water and allow to soak before cleaning.
- Air-dry all parts after each use.

**Caution** - Do not use any abrasive materials or cleaning products on any part of the air fryer.

**Caution** - Never put the air fryer in the dishwasher or immerse it in water or any other liquid.

Only use genuine Avalla accessories designed for your air fryer.

# Health and safety

## Symbols from the unit and packaging



Read the instruction manual



Class I Construction (Earthed)



European Conformity



Caution, hot surface

## The following must always be observed for safety

- Spilled food can cause serious burns. Keep the unit and power cord away from children. This unit is not intended to be used by children and close adult supervision is required if using in the vicinity of children. Never drape the power cord over the edge of a counter, plug into a low-lying power outlet or use an extension lead. Doing so could cause a tripping hazard or allow the unit or its power source to come into reach of children or animals, all posing a spillage hazard.
- This appliance can be used by children aged from 8 years and above if they have been given supervision or instruction concerning use of the appliance in a safe way and if they understand the hazards involved. Cleaning and user maintenance shall not be made by children unless they are older than 8 and supervised. Keep the appliance and its cord out of reach of children aged less than 8 years.
- Persons with lack of experience or knowledge, reduced physical, sensory, or mental capabilities, can use this appliance if they have been given supervision or instruction concerning use of the appliance in a safe way.
- This appliance is intended to be used in household and similar applications such as:
  - Staff kitchen areas in shops, offices and other working environments;
  - Farm houses;
  - By clients in hotels, motels and other residential type environments;
  - Bed and breakfast type environments.
- Component parts must only be replaced with identical repair parts.
- If the power cord is damaged, it must be replaced by the manufacturer, its service agent, or similarly qualified persons.
- The appliance must be disconnected from its power source during servicing, cleaning or when not in use. Do not use chemicals or abrasive cleaners to clean the appliance unless otherwise specified in this manual.
- Always operate the unit from a grounded power outlet of equal voltage, frequency and rating as indicated on the product identification plate.
- Do not operate with wet hands. Keep the main unit away from sources or water, moisture, or any other liquids. Do not rinse the air fryer base, power cord, power connection.
- Do not leave the unit running unattended.
- Do not immerse the air fryer or any of its electrical components.
- Do not unplug, move, or tilt the unit while it is in operation. When moving the unit, ensure it's cool and it does not contain any hot contents.
- Do not unplug by pulling on the power cord.
- Do not operate the unit if it is dropped, damaged or showing signs of product malfunction.
- The unit must be installed in accordance with national wiring regulations.
- The appliance must be stored in a manner to prevent damage.
- Do not place in direct sunlight or near objects that may cause mechanical vibration or shock.
- Do not use the appliance where combustible / flammable gases or vapours are present, or in areas of high humidity.
- The cooking basket has a non-stick coating, to avoid scratches use wooden or plastic ladles only.
- You must only use the provided original cooking basket and accessories / parts and the cooking basket must be installed whilst the unit is on.
- Carefully remove and discard all packaging including the protective plug cover. Some parts may pose a choking hazard for children.
- Always ensure the appliance is properly assembled before use.
- This is intended to be used on a counter top only and it must be level, clean and dry.
- Clean up any spilled food or residue on appliances, utensils and surfaces in a manner which prevents a health risk to you and others. Be extra careful with raw foods, especially meats.

- Do not place any part of the unit or its accessories on or next to any heat source such as an oven electric burner, radiator etc.
- Do not cover, block, tamper with, disassemble or alter the air vents.
- Always allow the unit to fully cool down before putting on or taking off any parts or accessories, handling, cleaning, or storing.
- Do not place food or liquid into the air fryer base, it must be put into the cooking basket only.
- Do not operate the unit without food or liquids in the removable cooking basket for more than 5 minutes.
- Do not use this appliance for deep frying.
- Do not exceed the food or liquid filling levels detail in this manual.
- Before placing the cooking basket into the air fryer, ensure both are dry by wiping with a dry soft cloth, only do this when the unit is cool and disconnected from the mains supply.
- Do not sauté or fry with oil using this unit.
- Never connect this unit to an external timer or separate remote-control system.
- Do not touch hot surfaces, the surfaces of the unit will become hot during operation and will retain residual heat after use. Always wear heat protection such as oven mitts and use the handles and knobs on the unit.
- The cooking basket can become very heavy when it contains food or liquids, be very careful not to drop it, especially when it contains hot contents.
- Always place the cooking basket on a heat resistant surface when it's hot.
- Do not let the power cord touch hot surfaces or allow it to get wet.
- Do not cover the air intake vent or exhaust vent while the unit is operating. Doing so will prevent even cooking and may damage the unit or cause it to overheat.
- Always ensure adequate space above and around the air fryer for air circulation.
- Always ensure cooking basket is properly closed before operating. Do not use the air fryer without the cooking basket installed.
- Do not clean any part of the air fryer with metal scouring pads.

#### **A-195 - Pressure Cooker Mode**

- Extreme care must be taken when this unit is under pressure. It cooks under pressure. Make sure the unit is properly sealed prior to operation. Do not attempt to open the cooker lid until all pressure has been released from the unit, and the contents have been allowed to cool slightly.
- Always use heat protection and keep hands, face, and other body parts away from the pressure release valve when venting. Ensure it's not directed towards the power cord, power outlet, other appliances, walls, or cabinets.
- If the cooker lid will not unlock, this indicates that it is still under pressure, and you must not attempt to force it to unlock. Doing so can be extremely hazardous. Press the pressure release, using heat protection and avoiding contact with the released high temperature steam. When the steam is completely released, the float valve will move to the lower position, allowing the cooker lid to be removed safely.
- When you remove the cooker lid, additional high temperature steam may escape. Always use heat protection and keep your hands, face and other body parts away from the unit. Always lift and tilt the cooker lid away from you.

**Failure to abide by any of these warnings could result in a fire, explosion, electric shock, injury, death, and property damage.**

# Disposal



The adjacent symbol of a crossed-out wheeled bin indicates that this device is subject to Directive 2012/19/EU. This directive states that you must not dispose of this device with your general household waste at the end of its working life, but rather take it to a specially established collection point, recycling centre or waste disposal company. This disposal is free of charge for you. Protect the environment and dispose of it properly.

## Troubleshooting

Issue	Cause identification	Solution
Food not fully cooked	Too much food in basket	Reduce the amount being cooked at one time
	Cooking temperature too low / Cooking time too short	Increase cooking temperature and/or time
Uneven cooking	Some foods benefit from being turned over	Turn food over halfway through cooking time
Basket does not slid into unit	Too much food in basket	Reduce the amount being cooked at one time
	Unit obstructed	Check the basket and unit for obstructions, clean any food debris

## Troubleshooting - A-195 Pressure Cooker

Issue	Cause identification	Solution
Difficult to Attach Cooker Lid	The silicone ring is not correctly fitted	Place the silicone ring in the correct position
	Floating valve stuck on the bar	Push the bar slightly
Steam Leaking	Silicone ring either not in place, dirty, damaged, or not correctly fitted	Refit the silicone ring, it must be fitted correctly, clean and free from any damage / defects
Float Valve Leaking	Dirt in the anti-clog cap or float valve	Clean the anti-clog cap or float valve
	Damaged anti-clog cap	Replace the anti-clog cap
Float Valve Does Not Rise	Insufficient food in the multi - cooker	Add food and water in-line with directions

# Specifications

	A-171	A-175	A-177	A-195*
Power	1400W	1200W	1400W	1200W 800W
Bowl Capacity	5.5L	4L	5L	4L
Dimensions	348*287*345mm	328*230*305mm	350*249*315mm	305*255*305mm 305*255*280mm
Weight	4.2Kg	3.4Kg	4.8Kg	5.5Kg 4.6Kg
Working Pressure	N/A	N/A	N/A	40kPa

\* Where applicable specifications for the A-195 are shown for both modes, with Air Fryer on top and Pressure Cooker below.

Avalla Ltd. Unit A 73, Common Road, Chandler's Ford,  
Eastleigh, SO53 1HE. United Kingdom  
Company no. 13477899  
support@avalla.com