

Avalla

Air Conditioner

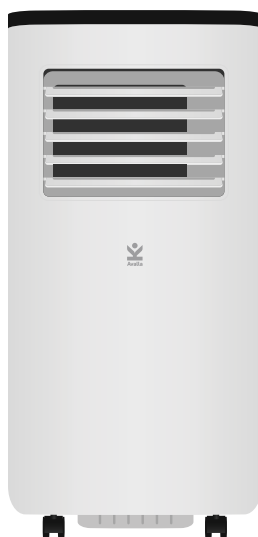

S-50



S-220

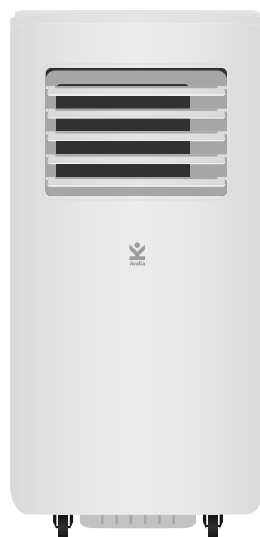

S-360

Read this manual carefully before use and keep it for future reference. Failure to do so may result in injury, property damage and may void the warranty.



Contents

03	Quick start guide <ul style="list-style-type: none">• Hose connection and setup
04	Parts guide: S-50
05	Parts guide: S-220
06	Parts guide: S-360
07	Features and guidance <ul style="list-style-type: none">• Settings
08	Timer function
09	Remote Control
09	Specifications
10	Built-in automatic protections <ul style="list-style-type: none">• Automatic Defrost• Overload Protection
10	Drainage
11	Maintenance and storage <ul style="list-style-type: none">• Cleaning the air filter• Storage• Disposal
12	Troubleshooting
12	Symbols from the unit
13	Health and safety <ul style="list-style-type: none">• General safety instructions
14	<ul style="list-style-type: none">• Servicing safety precautions
15	<ul style="list-style-type: none">• Connection to the power supply

Quick start guide

Hose connection and setup

Place the unit on a level surface with at least 50cm of free space around it, to allow good air circulation. Allow the unit to stand upright for at least 24 hours after delivery or being stored on its side.

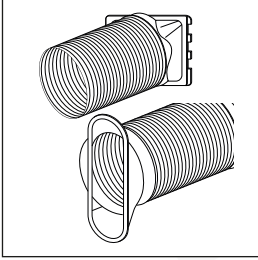

Attach the hose connector to one end of the exhaust hose.

If using the window kit, attach the windows kit adapter to the other end of the exhaust hose.

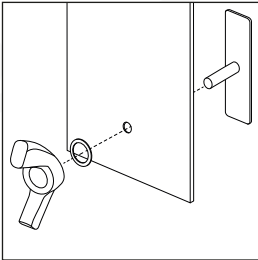

Insert the fastening clasp into the window kit and secure with washer and wingnut.

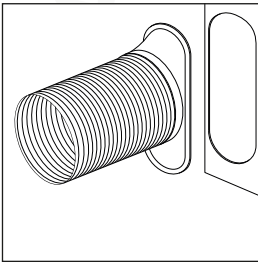

Extend the window kit to the height of your window. Attach the exhaust hose to the window kit.

Close your window to secure the window kit in place.

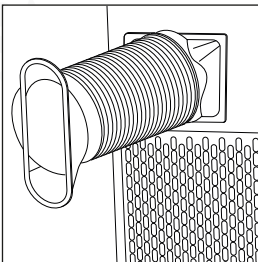

Attach the hose connector to the air exhaust on the unit, then connect to a mains power supply and turn the unit on.

⚠ Warning: Do not operate near combustible or explosive materials, heat sources, or any objects that may block air inlet and outlet. Keep the air inlet and outlet free of obstacles. Only use in rooms that exceed the size stated on the unit rating plate.

Parts guide: S-50

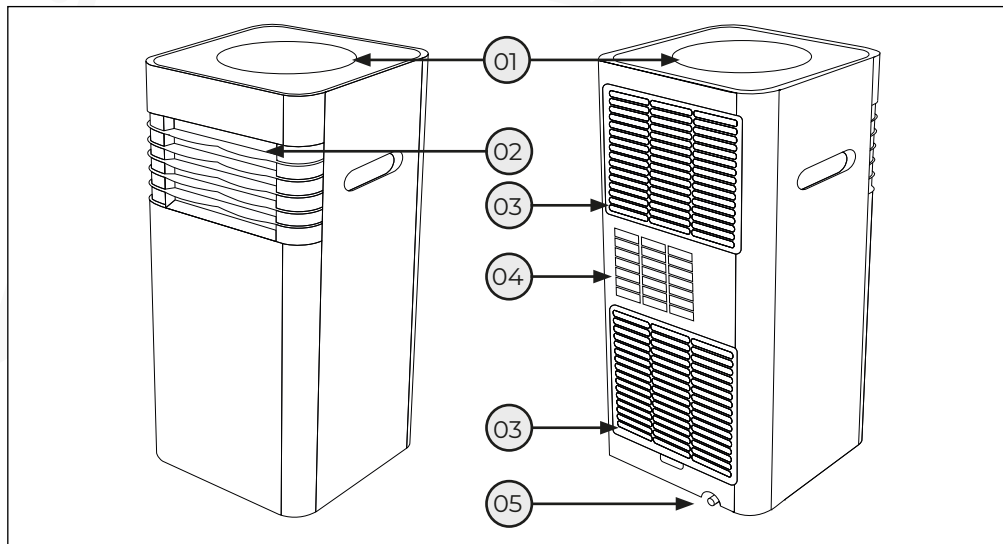

01. Control panel
02. Adjustable cool air outlet
03. Filtered air inlet

04. Hot air exhaust
05. Drain outlet

Touch controls

-  Sleep
-  Timer
-  Up
-  Down
-  Speed
-  Mode
-  Power

Display

-  Sleep active
-  Timer active
-  Low speed
-  High speed
-  Fan mode
-  Cool mode
-  Dehumidifier mode
-  Auto mode



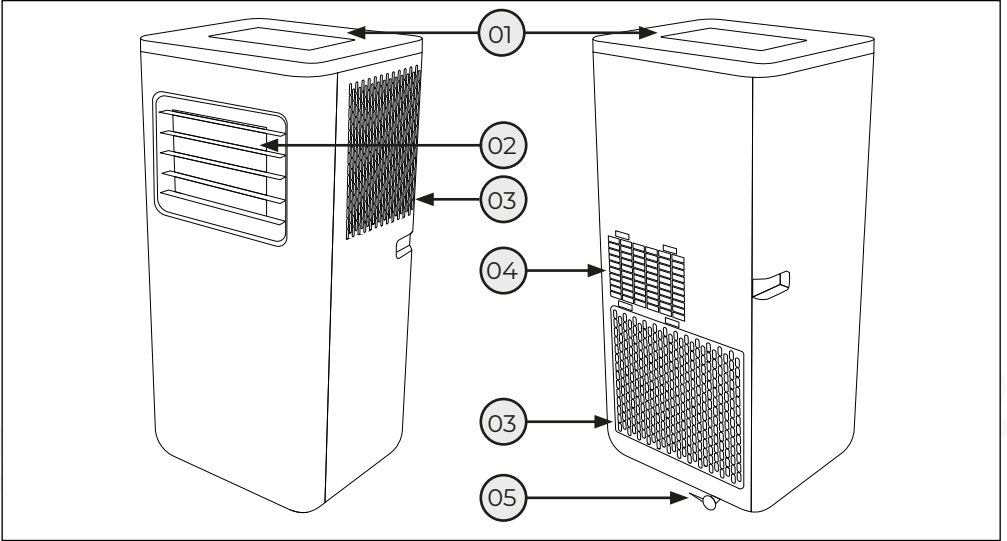





Parts guide: S-220





- 01. Control panel
- 02. Adjustable cool air outlet
- 03. Filtered air inlet

- 04. Hot air exhaust
- 05. Drain outlet

Touch controls

-  Sleep
-  Timer
-  Up
-  Down
-  Speed
-  Mode
-  Power
-  Swing

Display

-  Sleep active
-  Low speed
-  High speed
-  Auto mode
-  Cool mode
-  Dehumidifier mode
-  Fan mode
-  Power on
-  Lock active
-  Swing active

Parts guide: S-360

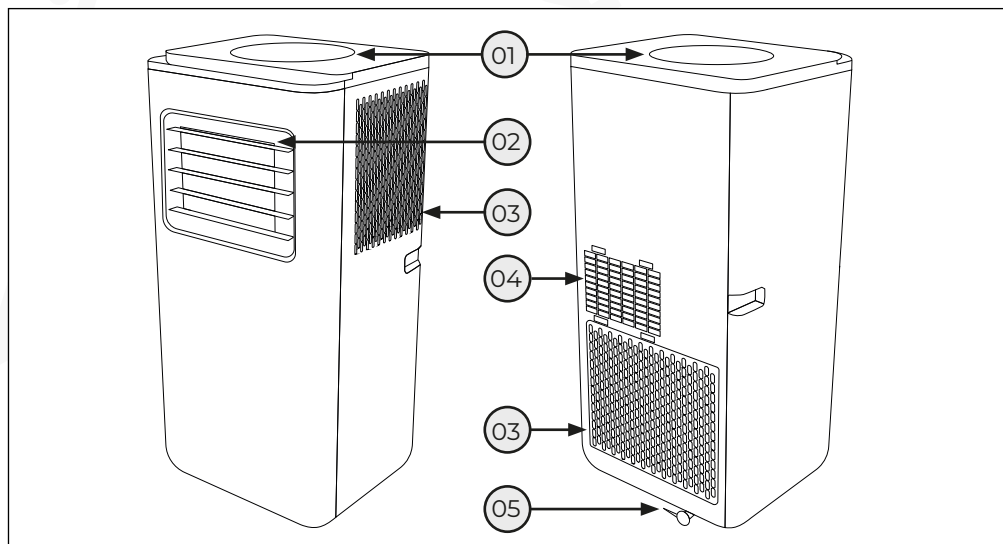

01. Control panel
02. Adjustable cool air outlet
03. Filtered air inlet

04. Air exhaust
05. Drain outlet

Touch controls

- Sleep
- Timer
- Up
- Down
- Speed
- Mode
- Power

Display

- Sleep active
- Timer active
- Low speed
- High speed
- Fan mode
- Cool mode
- Dehumidifier mode
- Auto mode

Features and guidance

Settings

Auto Mode - switches between cooling and fan mode.

- When the room temperature is above 24°C the unit will switch to Cooling Mode
- When the room temperature is below 24°C the unit will switch to Fan Mode

Cooling Mode – lowers the temperature of your room.

- Press **Mode** until the cooling light illuminates.
- Press **Up / Down** to adjust the temperature.
- Press **Speed** until the desired fan speed light illuminates.
- Press **Sleep**, if required, to enable sleep mode. The preset temperature will increase by 1°C after 1 hour, and increase by 2°C after 2 hours. The unit will operate for 6 hours in this mode.

Fan Mode – circulates the air in your room.

- Press **Mode** until the **Fan** mode light illuminates.
- Press **Speed** until the desired fan speed light illuminates.

Dehumidifying Mode – reduces the humidity level of your room.

- Whilst the unit is off, connect the drain hose to the drain outlet.
- Place the outlet of the drain hose into a bucket or drain, ensuring that the end is not submerged in water as this may cause an air lock. Make sure the hose is at an angle steeper than 20°
- Turn the unit on and then press **Mode** until the Dehumidifier light illuminates.
- The fan speed is not adjustable on dehumidifier mode.
- The exhaust hose is not needed. Dry air will blow out of the air exhaust.

Note: Water will not drain from the outlet until the 0.4L internal tank is full, this can take 4-5 hours.

If used without a drain hose attached, water will be collected in the internal tank. Auto-shut off will occur when tank is full and 'E4' will show on the display.

For optimal results, ensure the room temperature is above 18°C. In dehumidifier mode; below 16°C the unit will enter defrost mode.

Child Lock (S220) - disables button use when enabled

- Press and hold **Sleep mode** until the lock symbol lights up.
- Press and hold again to disable lock feature.

Swing Setting (S220) - turns automatic louvres on or off

Timer function

The timer has two ways of operating:

To turn the air conditioner on (when power is off)

- Press the **Timer** button
- Press **Up / Down** repeatedly to set the delay ON time.

To turn the air conditioner off (when power is on)

- Press the **Timer** button
- Press **Up / Down** repeatedly to set the delay OFF time.

To cancel timer, press the **Timer** button twice or press **Up / Down** repeatedly until display shows '0'

Note: Units represent hours. Eg '01' equals 1 hour.

Remote Control

The remote control doubles up the functions of the control panel for convenient operation at a distance.

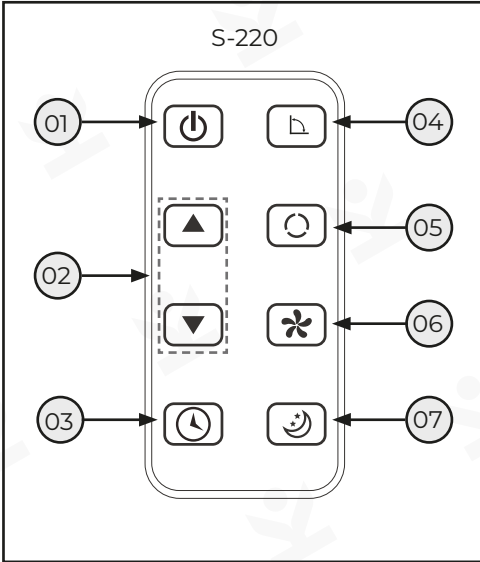

- 01. Power
- 02. Settings - up/down
- 03. Timer - on/off
- 04. Swing setting - on/off

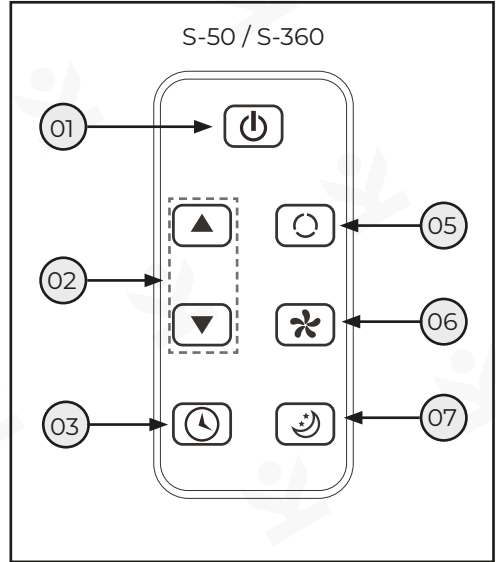

- 05. Mode select
- 06. Fan speed
- 07. Sleep mode - on/off

Specifications

	S-50	S-220	S-360
BTU	3000	9000	10000
Circulation	150m ³ /h	270m ³ /h	270m ³ /h
Temp' range	15-31°C	15-31°C	15-31°C
Input power	340W	950W	1100W

Built-in automatic protections

Automatic Defrost

When operating at low room temperatures, frost may build up on the evaporator. If this happens, the **Power** LED will begin blinking and the unit will automatically stop for a short time to carry out its automatic defrosting procedure.

Overload Protection

In the event of sudden power loss, to protect the compressor there is an automatic 3-minute delay until the compressor will restart.

Drainage

The self-evaporating system uses the collected water to cool the condenser coils, maximising performance and efficiency. There is no need to empty the drainage tank for this cooling operation except when using the dehumidifier mode or in high humidity conditions as typically the condensate water evaporates into the exhaust outlet. If used for extended periods of time, condensate may build up on the coils and excess water will drain into the tank. Should the tank become full, follow the steps below to drain.

For continuous or unattended operation, or operating in dehumidifier mode, please connect the attached drain hose to the drain outlet. Condensate water can be sent straight down a drain or collected in a suitable bucket.

- Switch off the unit.
- **For continuous drain:** Remove the plug from the drain outlet.
- **When drainage tank full:** Remove the plug from the drain outlet.
- Securely and properly connect the drain hose and make sure it is not kinked and is clear of obstruction.
- Place the end of the hose over a drain or bucket and ensure that water can freely flow out of the unit.
- Do not submerge the end of hose into water; otherwise it can cause an air lock in the hose.

To avoid water spillage:

- Negative pressure may cause some water to remain. To avoid this, ensure the drainage hose is at an angle steeper than 20°.
- Straighten the hose to avoid a trap existing in the hose.

Maintenance and storage

Cleaning the air filter

Excess dust can cause airflow to become restricted which will reduce efficiency and it can damage to the unit. The filter should be cleaned regularly.

- Ensure the unit is switched off and unplugged from the mains power.
- Remove the filter from the unit.
- Use a vacuum cleaner to remove dust from the filter.
- Rinse the filter under running water.
- Allow the filter to air dry completely before reinstalling.

Warning: Do not touch the air inlet or the evaporator surface, located behind the filter. Doing so could cause injury. Always ensure the filter is completely dry before reinstalling into the unit.

Storage

If the unit will not be used for an extended period, completely drain any water and dry the unit out by leaving the drainage cap off. Alternatively, dry the unit by leaving it on Fan Mode with the drainage pipe attached to the continuous drain outlet, until the drainage pipe becomes dry. Store in a well ventilated, dry area.

Disposal



The adjacent symbol of a crossed-out wheeled bin indicates that this device is subject to Directive 2012/19/EU. This directive states that you must not dispose of this device with your general household waste at the end of its working life, but rather take it to a specially established collection point, recycling centre or waste disposal company. This disposal is free of charge for you. Protect the environment and dispose of it properly.

Troubleshooting

Issue		Cause identification	Solution
The unit does not operate		Is the water level indicator illuminated?	Empty the drain pan
		What is the room temperature?	Operating range: 5°C - 35°C (A/C) / 15°C - 35°C (Dehumidifier)
The unit operates with reduced efficiency		Is the air filter clogged?	Clean the air filter
		Is the hose blocked?	Clear any obstacle or blockage
		Are windows or doors open?	Keep doors and windows closed
		Is the exhaust hose attached?	Securely attach exhaust hose
Water leakage		Leaking when moved / transported?	Empty water tank
		Is the drain hose bent or kinked?	Straighten the drain hose
Excessive noise		Is the unit positioned on flat ground?	Place the unit on flat, firm ground
		Do you hear a noise like flowing water?	Created by flowing refrigerant
Error code	E4	Excess water level in unit	Drain the water tank

Symbols from the unit



This unit uses a flammable refrigerant. If the refrigerant leaks and encounters fire or heat, it may create harmful gas and there is risk of fire.



Class I Construction (Earthed)



CE Certified



Read the user manual carefully before operation.



Service personnel are required to carefully read the user manual.

Health and safety

General safety instructions

- **The following must always be observed for safety**
- This appliance is not intended to be used by children. Persons with lack of experience or knowledge, reduced physical, sensory, or mental capabilities, can use this appliance if they have been given supervision or instruction concerning use of the appliance in a safe way and understand the hazards involved.
- The unit is designed only for use with R-290 propane gas. The refrigerant loop is sealed, only qualified technicians should perform servicing.
- Never discharge the refrigerant into the atmosphere.
- R-290 propane gas is flammable and heavier than air, it collects first in low areas, it can be circulated or dispersed by fans.
- If propane gas is present or even suspected, do not allow untrained personnel to attempt to find the cause. R-290 has no odour, the lack of gas smell does not indicate a lack of escaped gas. Do not allow to get in eyes, on skin, or on clothing. Do not breathe the vapours or gas.
- If a leak is detected, immediately evacuate all persons from the area, ventilate and contact the local fire department to advise them that a propane leak has occurred. Do not let any persons back into the area until the qualified service technician has advised that it is safe to return.
- Component parts must only be replaced with identical repair parts.
- Any person working on, or breaking into a refrigerant circuit, should hold a current valid certificate from an industry-accredited assessment authority, which authorises their competence to handle refrigerants safely in accordance with an industry, recognized assessment specification.
- If the supply cord is damaged, it must be replaced by the manufacturer, its service agent, or similarly qualified persons.
- The appliance must be disconnected from its power source during servicing, cleaning or when not in use. Do not use chemicals to clean the appliance.
- Always operate the unit from a grounded power outlet of equal voltage, frequency and rating as indicated on the product identification plate.
- Do not operate with wet hands. Keep the unit away from sources of water, moisture, or any other liquids.
- Do not leave the unit running unattended. Do not unplug or tilt the unit while it is in operation.
- Do not unplug by pulling on the power cord.
- Do not use an extension cord.
- Do not put objects on the unit, climb or sit on the unit.
- Do not insert fingers or other objects into the air outlet.
- Do not operate the unit if it is dropped, damaged or showing signs of product malfunction.
- The unit must be installed in accordance with national wiring regulations.
- Do not use means to accelerate the defrosting process.
- The appliance must be stored in a manner to prevent mechanical damage.
- Do not pierce or burn, even after use.
- Compliance with national gas regulations must be observed.
- Do not place in direct sunlight or near objects that may cause mechanical vibration or shock.
- Position the unit on an even / flat surface, away from excessive dust, and always maintain the unit to ensure that excessive dust does not accumulate anywhere on the unit.
-
- **Failure to abide by any of these warnings could result in a fire, explosion, electric shock, injury, death, and property damage.**

Servicing safety precautions

Please carefully follow this guidance when undertaking any servicing on this appliance. Any servicing **must** be carried out by a suitably qualified and registered individual.

Prior to beginning work, safety checks are necessary to ensure that the risk of ignition is minimized. For repair to the refrigerating system, all of the following precautions must be complied with prior to conducting work.

Work Procedure

Work must be undertaken under a controlled procedure to minimize the risk of a flammable gas or vapour being present while the work is being performed.

General Work Area

All maintenance staff and others working in the local area must be instructed on the nature of work being carried out. Work in confined spaces must be avoided. The area around the workspace must be sectioned off. Ensure that the conditions within the area have been made safe by control of flammable material.

Checking for Presence of Refrigerant

The area must be checked with an appropriate refrigerant detector prior to and during work, to ensure the technician is aware of potentially flammable atmospheres. Ensure that the leak detection equipment being used is suitable for use with flammable refrigerants, e.g. no sparking, adequately sealed or intrinsically safe.

Presence of Fire Extinguisher

If any hot work is to be conducted on the refrigeration equipment or any associated parts, appropriate fire extinguishing equipment must be available to hand. Have a dry powder or CO₂ fire extinguisher adjacent to the charging area.

No Ignition Sources

No person carrying out work in relation to a refrigeration system which involves exposing any pipe work that contains or has contained flammable refrigerant must use any sources of ignition in such a manner that it may lead to the risk of fire or explosion. All possible ignition sources, including cigarette smoking, should be kept sufficiently far away from the site of installation, repairing, removing and disposal, during which flammable refrigerant can possibly be released to the surrounding space. Prior to work taking place, the area around the equipment is to be surveyed to make sure that there are no flammable hazards or ignition risks. "No Smoking" signs must be displayed.

Ventilated Area

Ensure that the area is in the open or that it is adequately ventilated before breaking into the system or conducting any hot work. A degree of ventilation must continue during the period that the work is carried out. The ventilation should safely disperse any released refrigerant and preferably expel it externally into the atmosphere.

Checks to the Refrigeration Equipment

Where electrical components are being changed, they must be fit for the purpose and to the correct specification. At all times the manufacturer's maintenance and service guidelines must be followed. If in doubt consult the manufacturer's technical department for assistance. The following checks must be applied to installations using flammable refrigerants:

- The charge size is in accordance with the room size within which the refrigerant containing parts are installed.
- The ventilation machinery and outlets are operating adequately and are not

- obstructed.
- If an indirect refrigerating circuit is being used, the secondary circuit must be checked for the presence of refrigerant.
- Marking to the equipment continues to be visible and legible. Markings and signs that are illegible must be corrected.
- Refrigeration pipe or components are installed in a position where they are unlikely to be exposed to any substance which may corrode refrigerant containing components, unless the components are constructed of materials which are inherently resistant to being corroded or are suitably protected against being corroded.

Checks to Electrical Devices

Repair and maintenance to electrical components must include initial safety checks and component inspection procedures. If a fault exists that could compromise safety, then no electrical supply must be connected to the circuit until it is satisfactorily dealt with. If the fault cannot be corrected immediately but it is necessary to continue operation, an adequate temporary solution must be used. This must be reported to the owner of the equipment, so all parties are advised. Initial safety checks must include:

- Those capacitors are discharged: this must be done in a safe manner to avoid possibility of sparking.
- That no live electrical components or wiring are exposed while charging, recovering or purging the system.
- That there is continuity of earth bonding.

Connection to the power supply

Caution: Risk of electric shock. Do not open.

- This appliance is supplied with a moulded 3 pin mains plug for your safety. The value of the fuse fitted is marked on the pin face of the plug. Should the fuse need replacing, ensure the substitute is of the correct rating, approved to BS1362 and ASTA ⚡ or BSI ⚡ Kite marked.
- The fuse cover is removable with a small plain slot screwdriver. Ensure the fuse cover is replaced before attempting to connect the plug to an electrical outlet. If the cover is missing, a replacement must be obtained or the plug replaced with a suitable type.
- If a replacement plug is to be fitted this must be carried out by a qualified electrician.
- The damaged or incomplete plug, when cut from the cable should be disabled to prevent connection to a live electrical outlet.
- This appliance is Class I and is designed for connection to a power supply matching that detailed on the rating label and compatible with the plug fitted.
- If an extension lead is required, use an approved and compatible lead rated for this appliance. Follow all the instructions supplied with the extension lead.
- Class I ⚡: Products with this symbol must have metal parts connected to electrical earth by an earth conductor. The basic requirement is that no single failure can result in dangerous voltage becoming exposed so that it might cause electric shock.

Important: If using an extension lead, follow the instructions that came with your lead regarding maximum load while cable is wound. If in doubt, ensure that the entire cable is unwound. Using a coiled extension lead will generate heat which could melt the lead and cause a fire.

Avalla Ltd. Unit A 73, Common Road, Chandler's Ford,
Eastleigh, SO53 1HE. United Kingdom
Company no. 13477899
support@avalla.com