

Wellbeing Starts At Home



f77

Super Oven Pro

INSTRUCTION MANUAL

FRIDJA



1. INTRODUCTION

Thank you for choosing the Fridja f77 Super Oven Pro.

Designed for modern kitchens and everyday efficiency, the Fridja Super Oven Pro delivers fast, oil-free cooking powered by a high-performance convection fan. With a spacious 30L capacity, smart cooking modes, and a sleek matte black finish, it's built for those who want versatility without compromising on style. From the premium 5 sided stainless steel interior to the intuitive digital timer and double glass doors, every detail is crafted for convenience, safety, and consistently delicious results.

Wellbeing Starts At Home



Scan this code to see your Super Oven Pro in action!

2. SPECIFICATIONS

Model: F77/BLK

Capacity: 30 Litres

Voltage: 220- 240V~ 50/60Hz

Power: 1600W

Instruction Booklet: G-1.0

For household use only



SCAN THE QR CODES

Check out our social media channels now.

3. IMPORTANT SAFEGUARDS

When using any electrical appliance, basic safety precautions should always be followed:

- Read all instructions before using this appliance.
- Avoid touching the top or sides during use, as they can become hot. Take extra care when opening the oven after use and always protect your hands with non-slip oven gloves.
- To prevent electric shock, do not immerse cord, plug or appliance in water or other liquid.
- Keep appliance and cord out of reach of children.
- Unplug when not in use and before cleaning. Allow to cool before handling parts.
- Do not operate the appliance if the cord or plug is damaged or if the appliance malfunctions.
- Use only on a stable, heat-resistant surface. Maintain 15 cm clearance on all sides. Be sure the cord is not resting against the back of the Air Fryer Oven.
- Keep the power cord away from hot surfaces and do not let it hang over table or counter edges.
- Do not line the bottom of the oven or cover the heating elements or vents with foil, as this may cause overheating or fire. Foil may be used on the baking tray, provided it does not block airflow or touch the oven walls.
- This appliance is for household use only.
- Accessories and crumb tray should be cleaned regularly to avoid fire hazards.

4. WHAT'S IN THE BOX

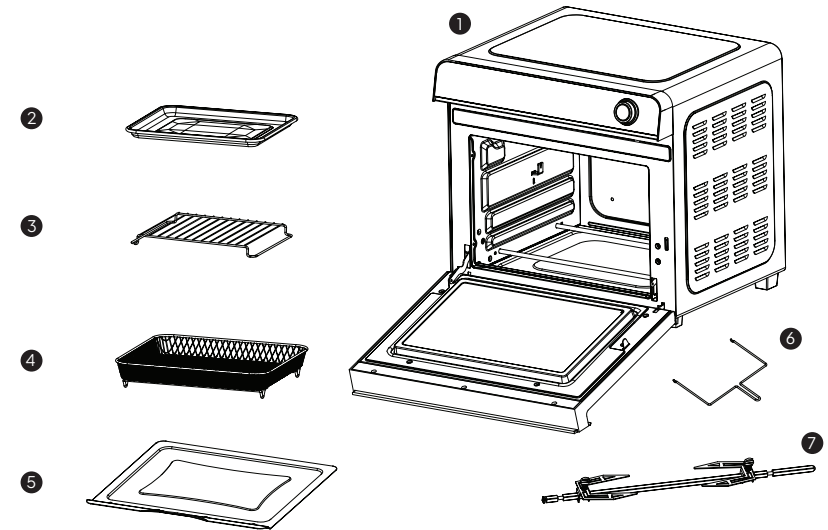

1. Fridja Super Oven (F77/BLK)

2. Baking Tray

3. Grill Rack

4. Air Fry Basket

5. Crumb Tray

6. Rotisserie Handle

7. Rotisserie Fork

8. Instruction Manual

9. Recipe Book

2. Baking Tray

The baking tray can be used in any of the rack positions. We recommend placing the baking tray below the air fry basket when air frying, as it doubles as a drip pan.

3. Grill Rack

The grill rack can be used in any of the rack positions. Food may be placed directly onto the grill rack. If cooking food that may release grease, place the baking tray underneath the grill rack to catch drips. The crumb tray is designed for collecting crumbs, not for catching grease.

4. Air Fry Basket

The air fry basket is grated to allow air to pass through for even cooking. The air fryer basket should be placed on top of the grill rack. It does not slot in the sides.

5. Crumb Tray

Always ensure that the removable crumb tray is in place at the bottom of the oven whenever the appliance is in use.

Never operate the appliance without the crumb tray properly in place at the bottom. Do not insert it into any of the rack positions.

SUPER OVEN

6. Rotisserie Fork

The rotisserie fork is designed to hold large cuts of meat, such as a whole chicken, allowing it to rotate slowly for even cooking and crispy skin. Always truss the meat securely to prevent movement during rotation. Ensure the forks are firmly tightened and the food is held securely before inserting into the Super Oven Pro. First push the skewer into the right-hand side rotisserie slot. Once it's properly engaged, rest the opposite end onto the left-hand side bracket. Make sure the food does not touch the top heating element while rotating. Always double-check that the skewer and forks are securely in place before starting the rotisserie function.

7. Rotisserie Handle

The rotisserie handle allows you to safely insert and remove the hot rotisserie fork from the oven. Always use the handle when handling the rotisserie fork to avoid burns or injury.

5. GETTING STARTED

Before First Use

- Remove all packaging materials, printed documents from both the exterior and interior of the oven. Remove the handle protective film.
- Take out all accessories (rack, baking pan, air fry basket) and wash them with warm, soapy water using a soft sponge. Rinse and dry well.
- Wipe the interior with a damp cloth to remove any dust from manufacturing.
- Place the oven on a flat, heat-resistant surface with at least 6 inches (15 cm) of space on all sides.
- Plug into a properly earthed 240V AC mains socket.

- **NOTE:** Run the oven empty at max temperature for 5 minutes to remove factory residue.
- A slight smell or smoke during first use is normal.

Using the Oven

- Place food on the appropriate tray or basket.
- Turn the oven on (7). Insert the tray into the recommended position.
- Select a preset or manually set the time and temperature use the rotating dial to adjust.
- Press the Start/Pause button (8) to begin cooking.
- To make adjustments during cooking, press the Start/Pause button (8) to pause, make your changes, then press again to resume.
- The oven will beep when the cooking is completed.
- Use oven mitts when handling hot trays or food.

Tips & Safety

- No preheating needed for air frying.
- Allow the oven to cool completely before cleaning or storing.
- Clean the crumb tray regularly to prevent build-up and fire risk.
- Keep 6 inches (15 cm) of space around the oven while in use.
- Do not immerse the appliance, cord, or plug in water.
- Keep cords away from hot surfaces.
- Avoid overcrowding trays allow space for airflow.
- Do not put oil on the bake pan, this may cause a fire.

SUPER OVEN

6. CONTROL PANEL & PRESET PROGRAMS

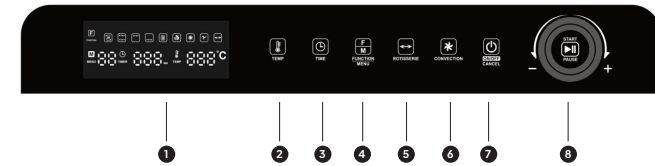

1. LED Display:

Displays the selected temperature, cooking time, and function mode. It also shows real-time countdown and status during operation.

2. Temperature Button:

Adjusts the cooking temperature manually. Press the button, then use the dial to set your desired temperature.

3. Timer Button:

Sets or adjusts the cooking time. Press to enter time mode, then turn the dial to increase or decrease the time. To adjust the time or temperature during cooking, first pause the oven using the Start/Pause button (8). Once paused, you can make your adjustments.

4. Function/Menu Button:

Press the Function/Menu button to switch between manual mode and preset programs. In manual mode, you can choose from various cooking functions (see section 7). In function mode, select from 18 preset programs, detailed later in this manual.

5. Rotisserie Button:

Activates the rotisserie function, allowing the rotisserie fork to rotate during cooking. Ideal for evenly roasting meats like whole chicken.

6. Convection Button:

Toggles between convection and strong convection modes. Convection circulates hot air for faster, more even cooking with crispier results.

7. Power Button:

Turns the Super Oven Pro on or off.

8. Start/Pause Button and Dial:

Press the button to start or pause cooking. Turn the dial to adjust settings in manual mode. After selecting temperature, time, or a cooking function, use the dial to make your adjustments.

7. LED DISPLAY

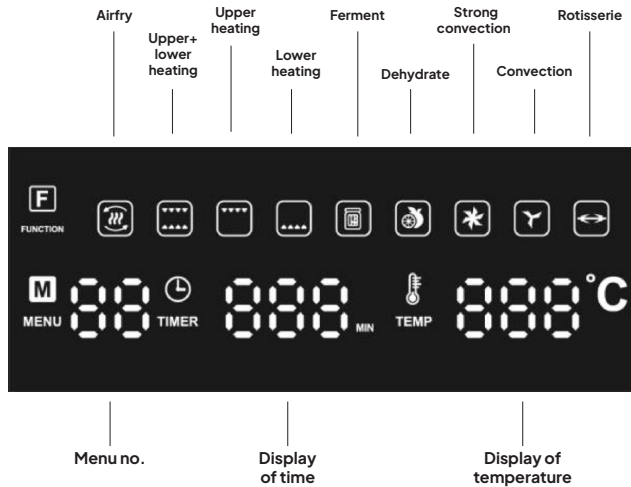

Setting description:

- Air fry:** 4 pcs upper heating elements+ strong convection.
- Upper + lower heating:** 2 pcs upper + 2 pcs lower heating elements+ convection.
- Upper heating:** 2 pcs upper heating elements.
- Lower heating:** 2 pcs lower heating elements.
- Ferment:** 2 pcs lower heating elements+ convection.
- Dehydrate:** 2 pcs lower heating elements+ convection.

8. DIGITAL AIR FRYER OVEN SETTING & COOKING CHART

Mode	Temp (°C)	Time (Min)
Air Fry	200	15
Upper+Lower Heating	150	30
Upper Heating	150	30
Lower Heating	150	30
Ferment	38	60
Dehydrate	50	60

9. HOW TO USE

Cooking time will vary depending on temperature, food type, thickness, and container. Adjust as needed.

1. Power On & Standby Mode

- Plug in the power cord. The display will flash once, indicating the unit is in shutdown mode.
- Press the Power button (7) to enter standby mode (function icons will flash).
- Use the Start/Pause dial (8) to select a cooking function and adjust the temperature and time.
- Press the Start/Pause button (8) to start cooking.
- Press the Start/Pause button again to pause or stop cooking.
- To power off from standby mode, press the Power button (7) again.

2. Function Selection

- Function Mode (Manual): Turn the dial in standby mode to select a function. Press Start/Pause Button (8) within 1 minute to begin.
- Press the Function/Menu button to enter Menu mode, where you can cook using preset programs. Turn the dial to browse the 18 available presets. Press the Start/Pause button (8) within 1 minute to begin cooking.
- Note: Air Fry function has Strong Convection by default. For other functions, you can manually enable convection or rotisserie.

3. Temperature Setting

- Press the Temp button (2), turn the dial to adjust.
- Press Start/Pause Button (8) within 1 minute to begin.
- Refer to the cooking chart for default temperature ranges.

4. Time Setting

- Press the Time button (3), turn the dial to adjust.
- Press Start/Pause Button (8) within 1 minute to begin.
- Refer to the cooking chart for default time ranges.

5. Add Food

- Place food on the tray, rack, or basket and insert into the correct oven layer.
- Always insert the crumb tray at the bottom.

6. Start Cooking

- Close the glass door and press Start/Pause Button (8) to begin.
- To adjust the time or temperature during cooking, first pause the oven using the Start/Pause Button (8).
- Once paused, you can make your adjustments.
- To pause, press Start/Pause Button (8); adjust time/temp during pause.
- To cancel, press Power button (7) again to return to standby.
- The oven will beep to signal the end of the cooking cycle.

7. Remove Food Safely

- Open the door carefully and keep your face away from the hot steam.
- Use the rotisserie handle to safely remove the rotisserie fork.
- Don't splash cold water on hot glass.

8. After Use

Unplug the appliance and let it cool completely.

Note: The oven does not need to be pre-heated for Air Frying.

Note: Cook times are estimates and may vary based on food type and preparation

SUPER OVEN

No.	Food Preset (Updated)	Function	Temp Default (°C)	Temp Range (°C)
1	Skin-On Fries	Airfry	180	200-160
2	Breaded Chicken Bites	Airfry	200	220-180
3	Buffalo Wings	Airfry	180	200-160
4	Roasted Chestnuts	Airfry	150	170-130
5	Sirloin Steak	Upper+lower heating	220	230-200
6	Whole Roast Chicken	Upper+lower heating	200	220-180
7	Garlic Butter Prawns	Upper+lower heating	180	200-160
8	Herb-Crusted Sea Bass	Upper+lower heating	230	230-210
9	Artisan Sourdough Toast	Upper+lower heating	200	220-180
10	Chocolate Chip Cookies	Upper+lower heating	150	170-130
11	Thin Crust Margherita Pizza	Upper+lower heating	200	220-180
12	Brioche Loaf	Upper+lower heating	150	170-130
13	Portuguese Custard Tarts	Upper+lower heating	200	200-160
14	Mini Quiches	Upper+lower heating	175	195-155
15	Maple-Glazed Sweet Potato	Upper+lower heating	220	230-200
16	Dehydrated Apple Slices	Dry fruit	70	90-50
17	Dried Mango	Dry fruit	90	90-50
18	Gentle Defrost	Dry fruit	30	55-30

SUPER OVEN

Temp Step (°C)	Time Default (min)	Time Range (min)	Time Step (min)
5	18	1-35	1
5	15	1-30	1
5	15	1-30	1
5	25	1-50	1
5	12	1-20	1
5	70	1-120	1
5	8	1-15	1
5	15	1-30	1
5	50	1-100	1
5	30	1-60	1
5	15	1-30	1
5	45	1-90	1
5	25	1-50	1
5	40	1-80	1
5	50	1-100	1
5	480	10-600	10
5	360	10-360	10
5	30	10-720	10

10. POWER CORD INSTRUCTIONS

A fixed power cord is provided to reduce the risk of tripping, which can occur with longer or detachable cords. If you choose to use an extension lead:

1. Ensure the extension lead is rated to handle at least the same electrical load as the appliance.
2. Arrange the lead so it does not hang over the edge of a worktop or table, where it could be pulled down or cause someone to trip.
3. Use a properly earthed (grounded) extension lead, especially if your socket or setup requires one for safety.

Do not use the appliance if the power cord is damaged. If the cord becomes damaged, it must be replaced by the manufacturer, its service agent, or a similarly qualified professional to avoid any risk.

NOTE:

1. Some worktop and table surfaces are not designed to withstand the prolonged heat generated by certain appliances. Do not set the heated unit on a finished wood table. We recommend placing a hot pad or trivet under your air fryer oven to prevent possible damage to the surface.
2. During initial use of this appliance,

some slight smoke and/or odour may be detected. This is normal with many heating appliances and will not recur after a few uses

11. STORING SUPER OVEN PRO

Allow the appliance to cool completely before storing. If storing the super oven Pro for long periods of time, make certain that it is clean and free of food particles. Store the Super Oven Pro in a dry location such as on a table or worktop or cupboard shelf. Other than the recommended cleaning, no further user maintenance should be necessary.

12. WARNING

When Super Oven Pro is in use or cooling down, please be sure there is a 15cm clearance between the Super Oven Pro and any other surface including cords. Be sure the cord is not resting against the back of the air fryer oven.

Note: Cook times are estimates and may vary based on food type and preparation

13. CLEANING & MAINTENANCE

Cleaning & Maintenance

- Always unplug the appliance and allow it to cool down completely before cleaning to avoid burns or electrical shock.
- Wipe down the exterior and interior surfaces with a soft, damp cloth. Make sure not to let water enter any openings or controls.
- Never immerse the appliance, plug, or cord in water or any other liquid.
- Use only mild, soapy water for cleaning. Avoid using harsh chemicals or solvents.
- Do not use abrasive cleaners, metal scouring pads, wire brushes, or harsh scrubbing tools, as these may scratch or damage the surfaces and non-stick coatings.

Dishwasher-Safe Parts

The following accessories are dishwasher safe (top rack recommended) and should be washed at temperatures below °40C:

- Baking tray
- Grill rack
- Air fry basket

Important: The crumb tray is not dishwasher safe and should be washed by hand only.

- Empty the crumb tray regularly after use to prevent build-up, which could become a fire hazard.
- Use a soft sponge or cloth with mild soap to clean it thoroughly, then dry it completely before reinserting.

Maintenance

- This appliance contains no user-serviceable parts.
- Do not attempt to repair or disassemble the unit yourself.
- For any issues beyond routine cleaning (such as electrical faults or damaged parts), please contact Fridja or an authorised service partner.

14. WARRANTY

Your Fridja Super Oven Pro comes with a 12 month warranty covering manufacturing faults. Proof of purchase required. Warranty excludes damage from misuse or wear and tear.



Scan the QR code to register your warranty now.

15. DISPOSAL

Please recycle this appliance responsibly. Do not dispose of it with household waste. Contact your local recycling centre or retailer for proper disposal.



For more tips and support, visit www.fridja.com



FRIDJA



UK REGISTERED ADDRESS
12 CELIA ROAD LONDON, N19 5ET
UNITED KINGDOM

www.fridja.com