

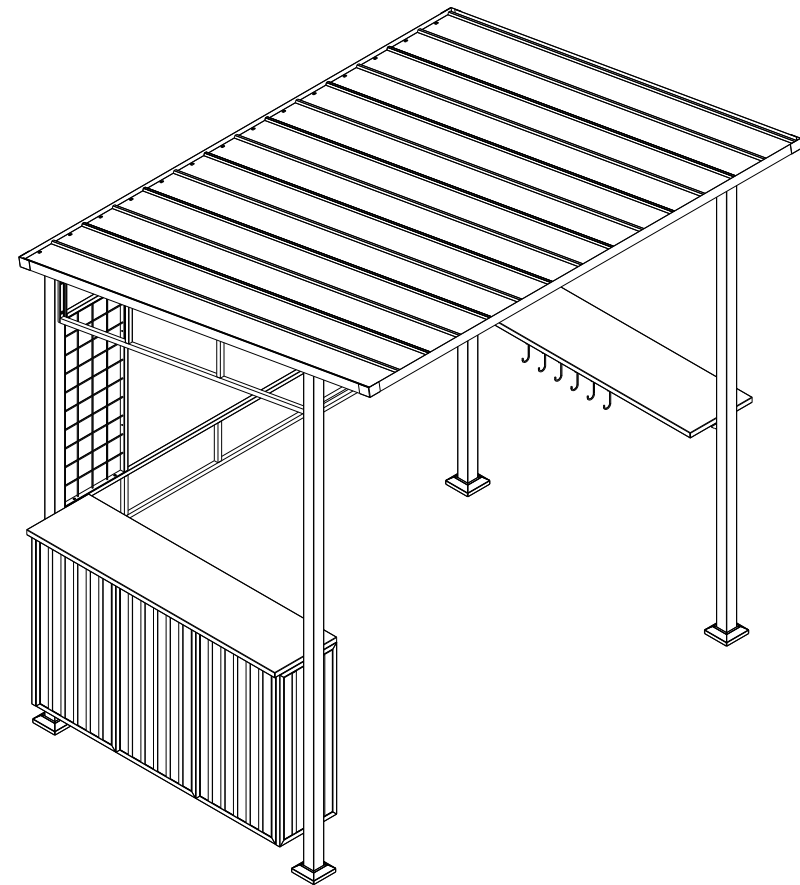

# ASSEMBLY INSTRUCTIONS

## 1.7m x 2.4m Single-Pitched Roof BBQ Gazebo



**IMPORTANT**  
**THIS DOCUMENT CONTAINS**  
**INFORMATION ABOUT WARRANTY & CARE**  
**INSTRUCTIONS**  
**PLEASE RETAIN FOR FUTURE REFERENCE**

**PRODUCT CODE: GB1005172410**

**3-4**      **Part 1 Precautions and Preparations**

**5-7**      **Part 2 Parts & Tools**

**8-13**     **Part 3**

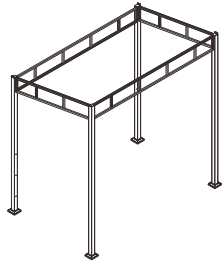

**14-25**   **Part 4**

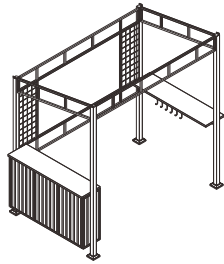

**26-31**   **Part 5**

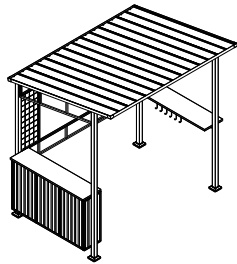

**32**      **Part 6 Help Center**



## **SAFETY ADVICE - BEFORE YOU START**

- 1. Ensure you read this manual before starting to assemble your BBQ Gazebo.**
- 2. Check you have all parts against the parts list in this manual.**  
**Do not throw away product packaging until you have established you have all the parts.**
- 3. Two or more people are required for assembly.**
- 4. Assemble your product on a flat surface.**
- 5. Do not assemble in inclement weather.**
- 6. Keep any plastic bags, fittings and tools out of reach of children and pets.**
- 7. Do not leave tools unattended during the assembly process.**
- 8. Do not modify this product, substitute parts or use other tools not provided and/or recommended to build your product, as this will void your warranty.**
- 9. There are heavy parts within this package. Ensure you lift with the correct posture and technique. Get help moving and/or lifting if necessary.**
- 10. Please only use this product for its intended purpose within a residential environment. Failure to do so will void your warranty.**
- 11. GRDN Living holds no responsibility for any damages caused due to normal wear and tear, incorrect assembly, misuse and/or negligence.**
- 12. Please recycle product packaging where possible.**

# ASSEMBLING THE GAZEBO

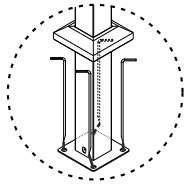

SOFT GROUND

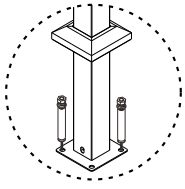

HARD GROUND

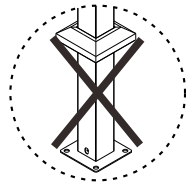

## RECOMMENDED



Tape Measure



Safety Gloves



Knife



Screwdriver



Pencil



Ladder



Spirit Level



Hammer



SDS Drill or Hammer Drill

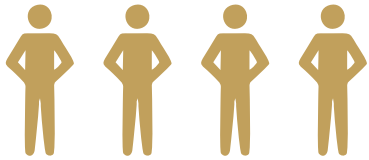

## FOR YOUR SAFETY AND CARING FOR YOUR GAZEBO

- Do not remain under or inside the gazebo in strong winds or heavy snowfall.
- Attaching ropes to the four corners of the gazebo can provide additional stability during severe weather.
- Curtains and netting should be properly tightened to prevent wind damage during severe weather.
- Remove accumulated snow from the roof promptly during snowfall.
- Do not use matches, candles or any open flames near the gazebo due to risk of fire.
- Regularly check the Gazebo is firmly fixed to the ground.
- Regularly check all fixings are secured.
- If any parts are missing, broken, damaged or worn, stop using the product until repairs are made using manufacturer authorised replacement parts.

# PARTS

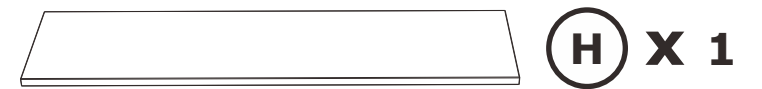
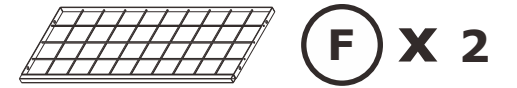
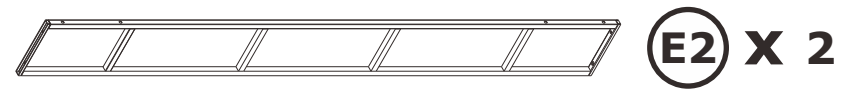
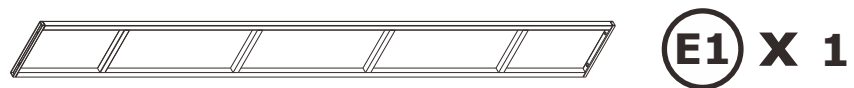
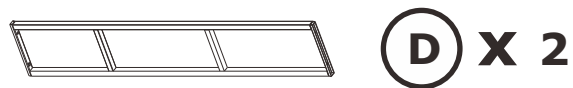
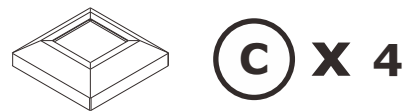
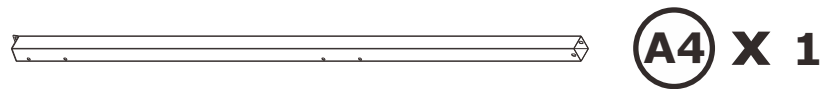
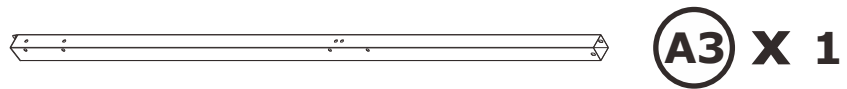
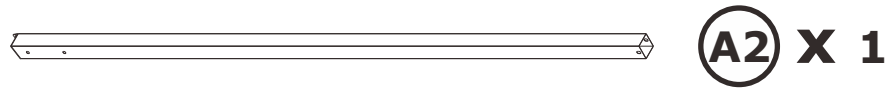
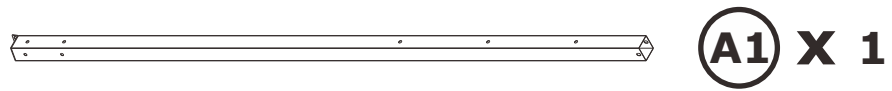

# PARTS



**M X 1**

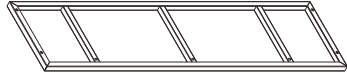

**N X 1**

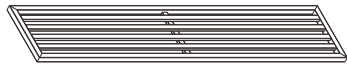

**P X 1**



**Q1 X 1**



**Q2 X 1**



**R X 2**



**S X 2**



**T X 7**

# HARDWARE

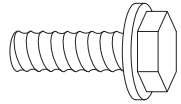

M6x15mm  
**(AA) X 79**



D8x180mm  
**(GG) X 16**

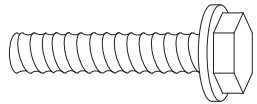

M6x25mm  
**(BB) X 31**



M6x60mm  
**(HH) X 8**

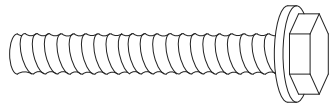

M6x35mm  
**(CC) X 13**

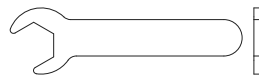

M6  
**(JJ) X 2**

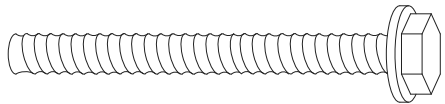

M6x50mm  
**(DD) X 4**

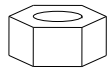

M6  
**(EE) X 4**



D16XM6X2mm  
**(FF) X 4**

# SPARE HARDWARE

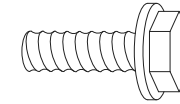

M6x15mm  
**(AA) X 4**

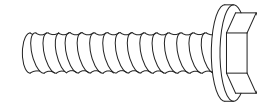

M6x25mm  
**(BB) X 2**

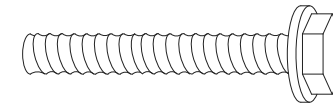

M6x35mm  
**(CC) X 1**

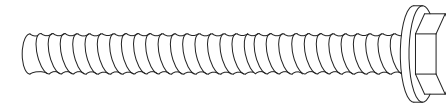

M6x50mm  
**(DD) X 1**

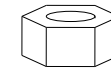

M6  
**(EE) X 1**



D16XM6X2mm  
**(FF) X 1**

# Part 3

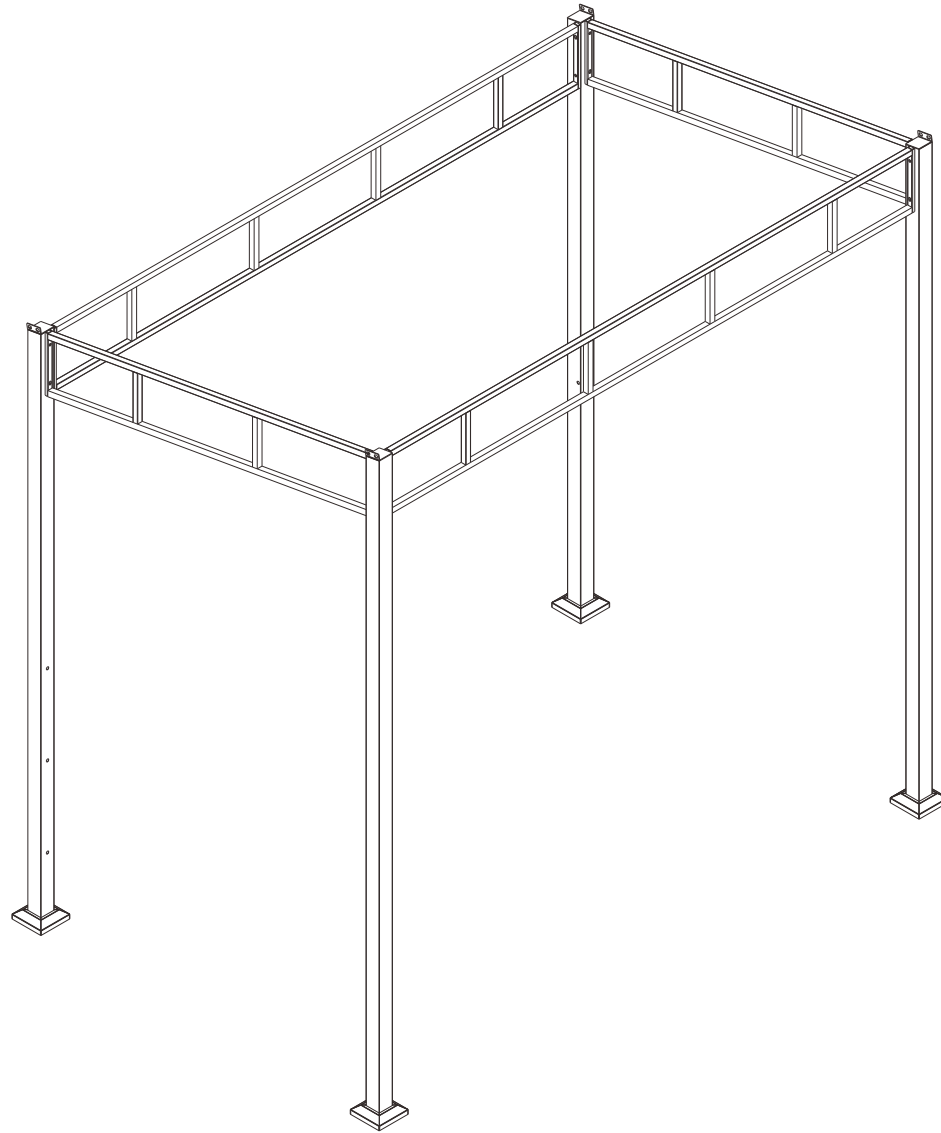

1

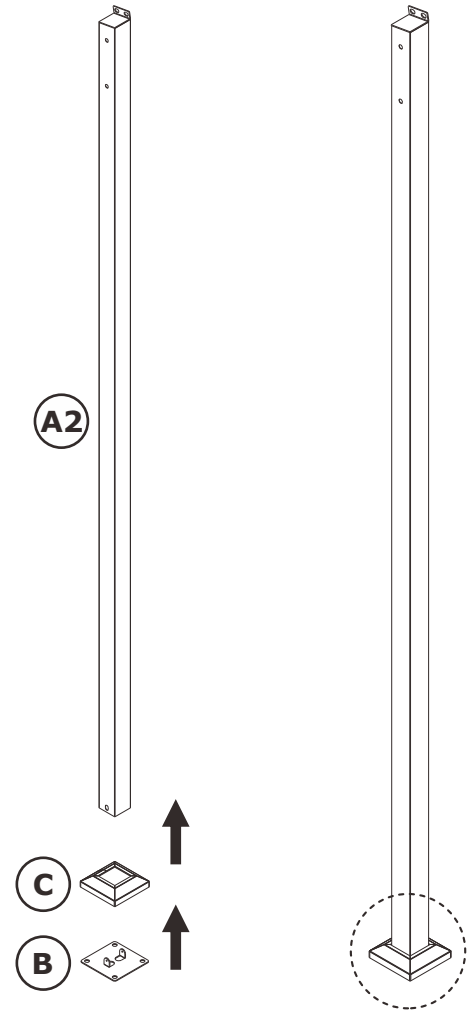
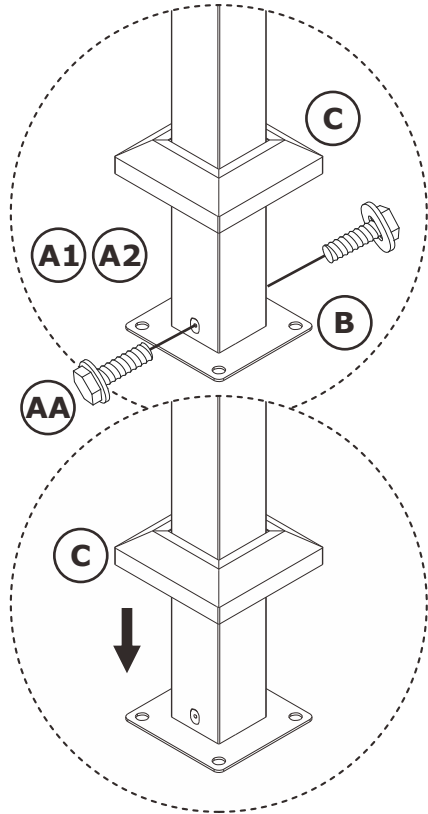
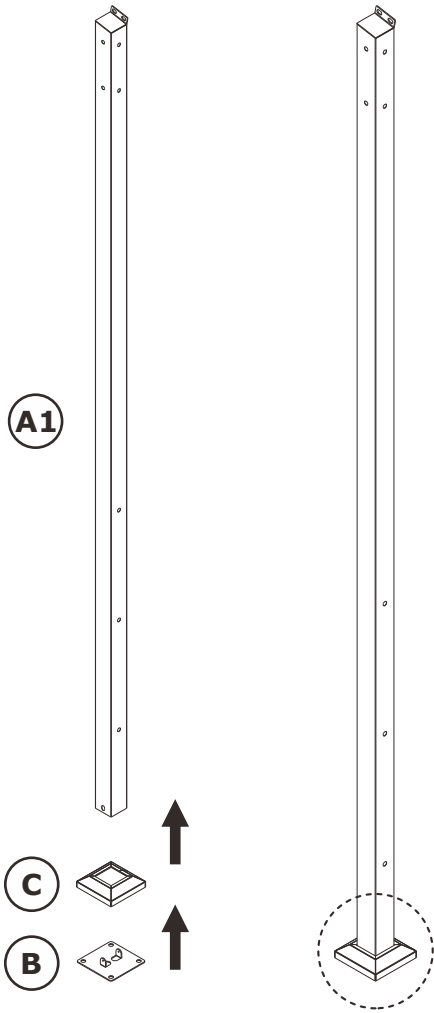
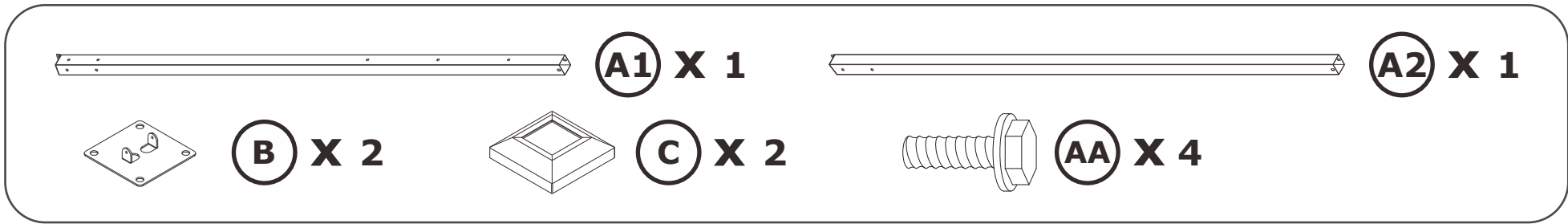

2

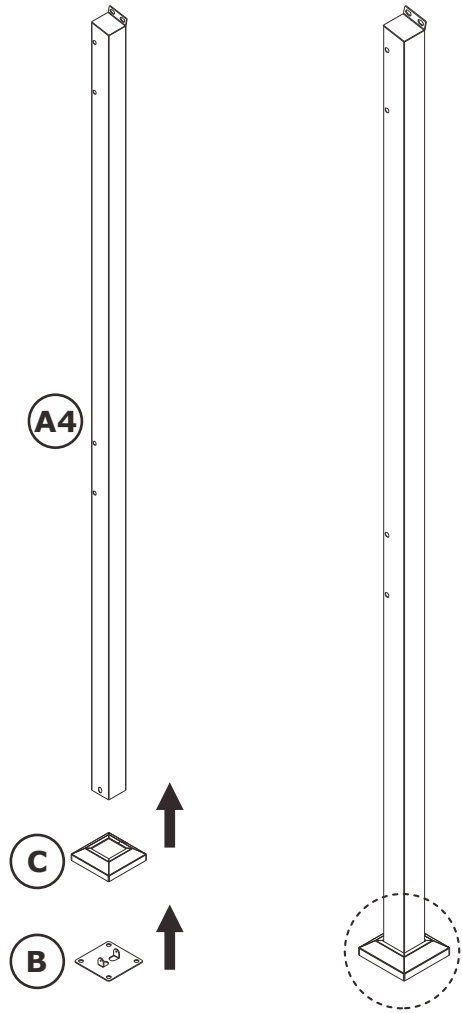
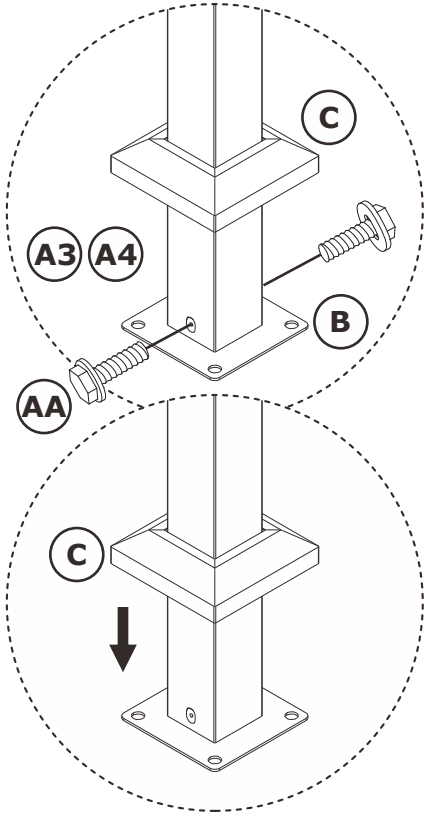
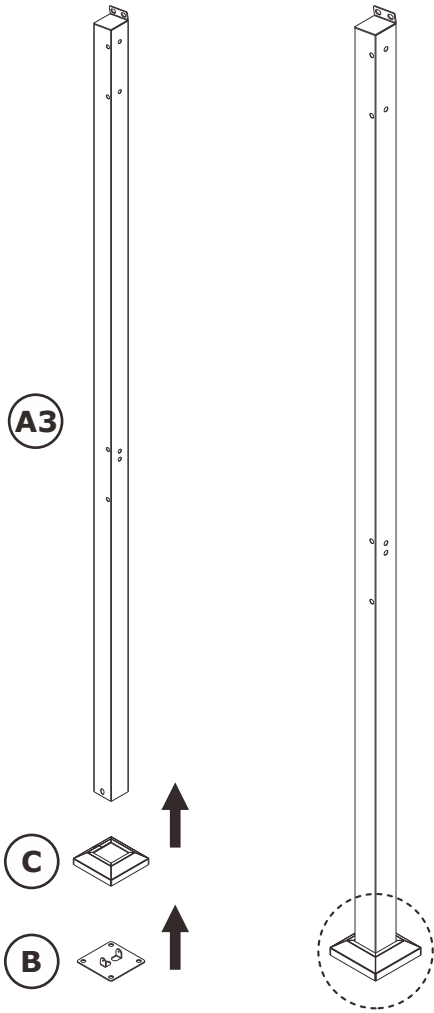
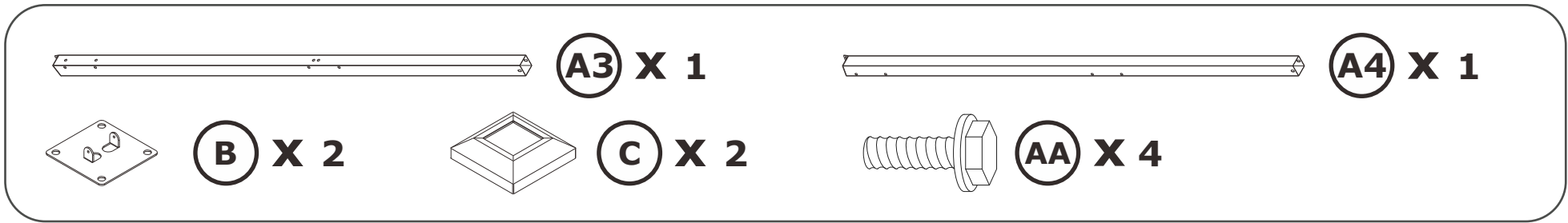

3

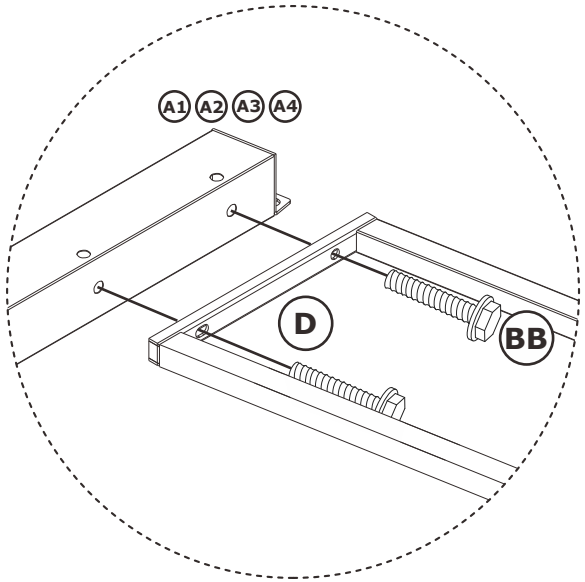
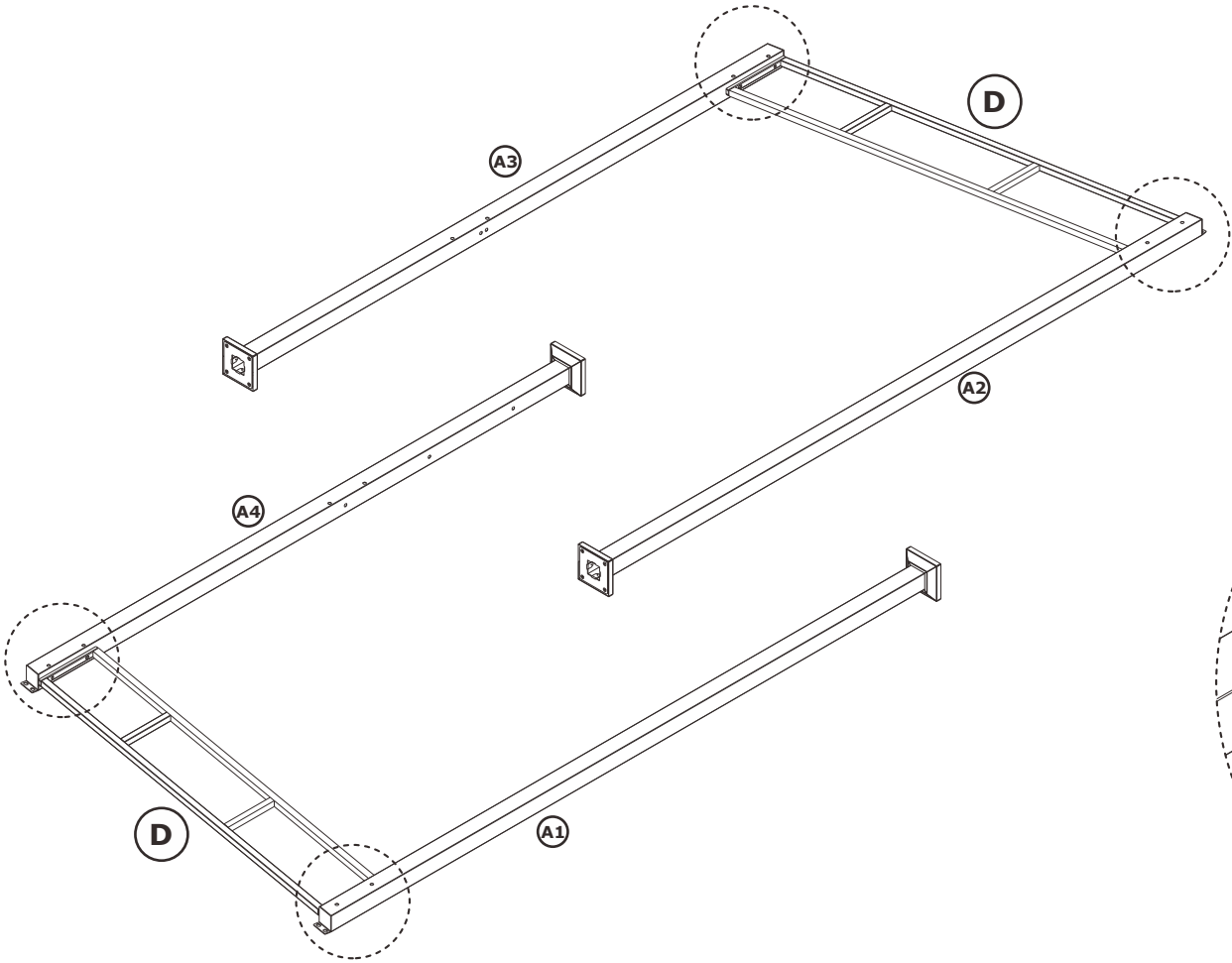

4

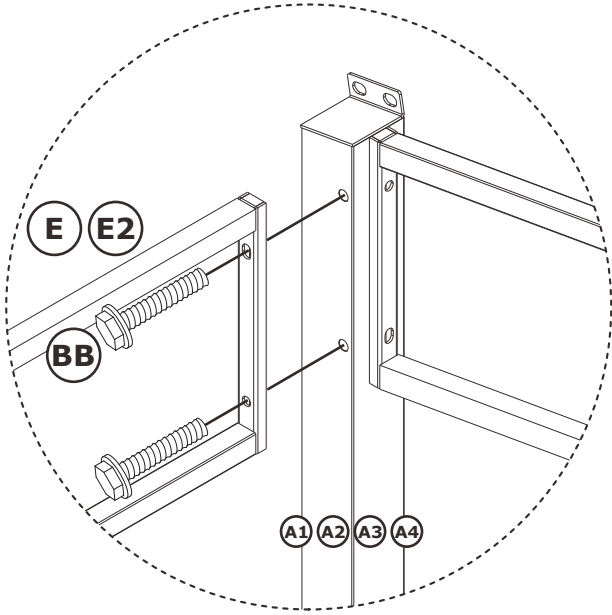
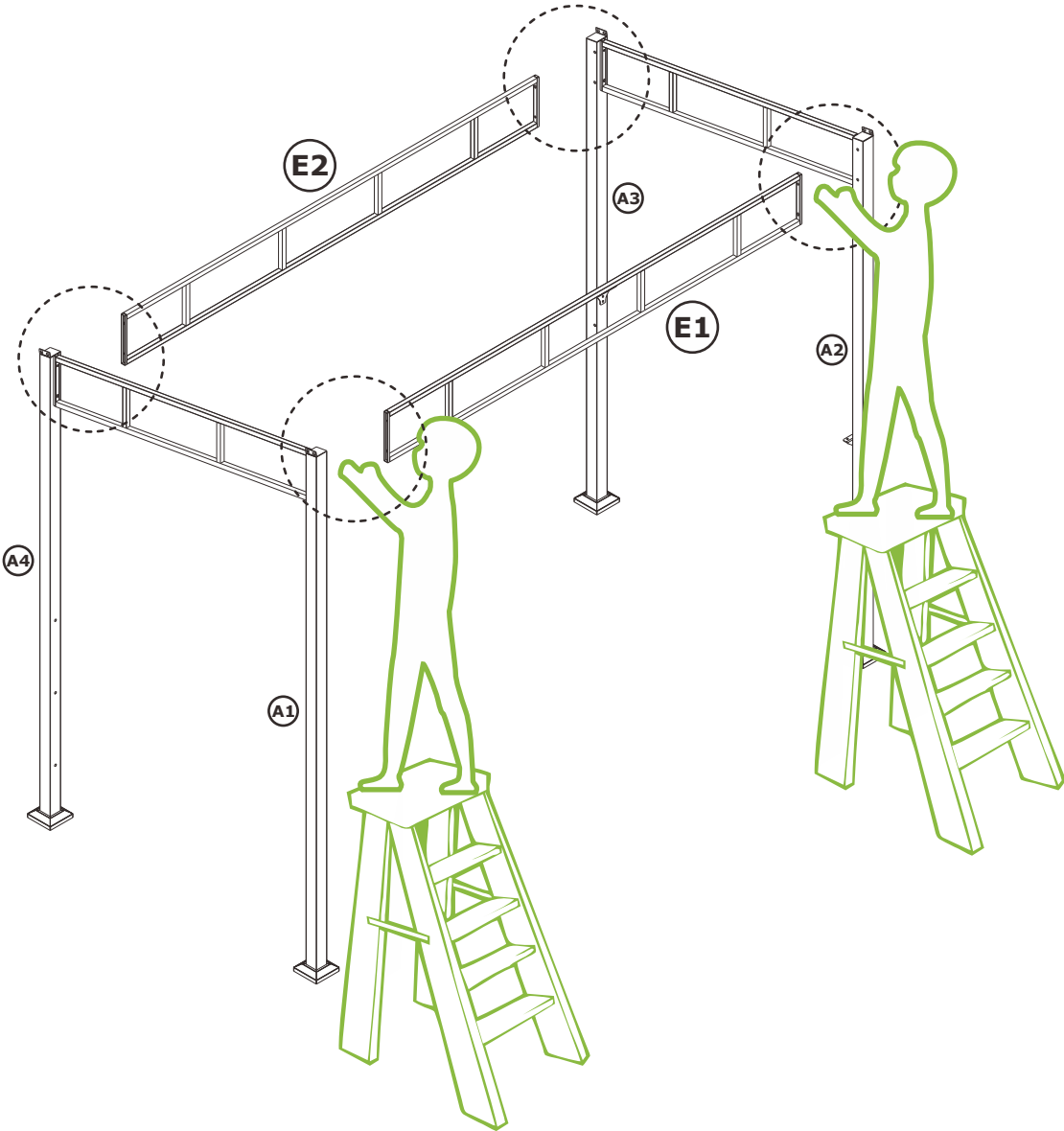
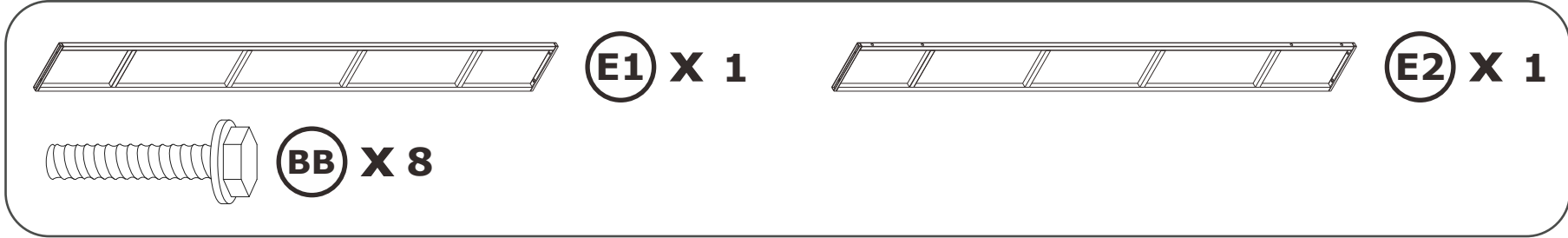

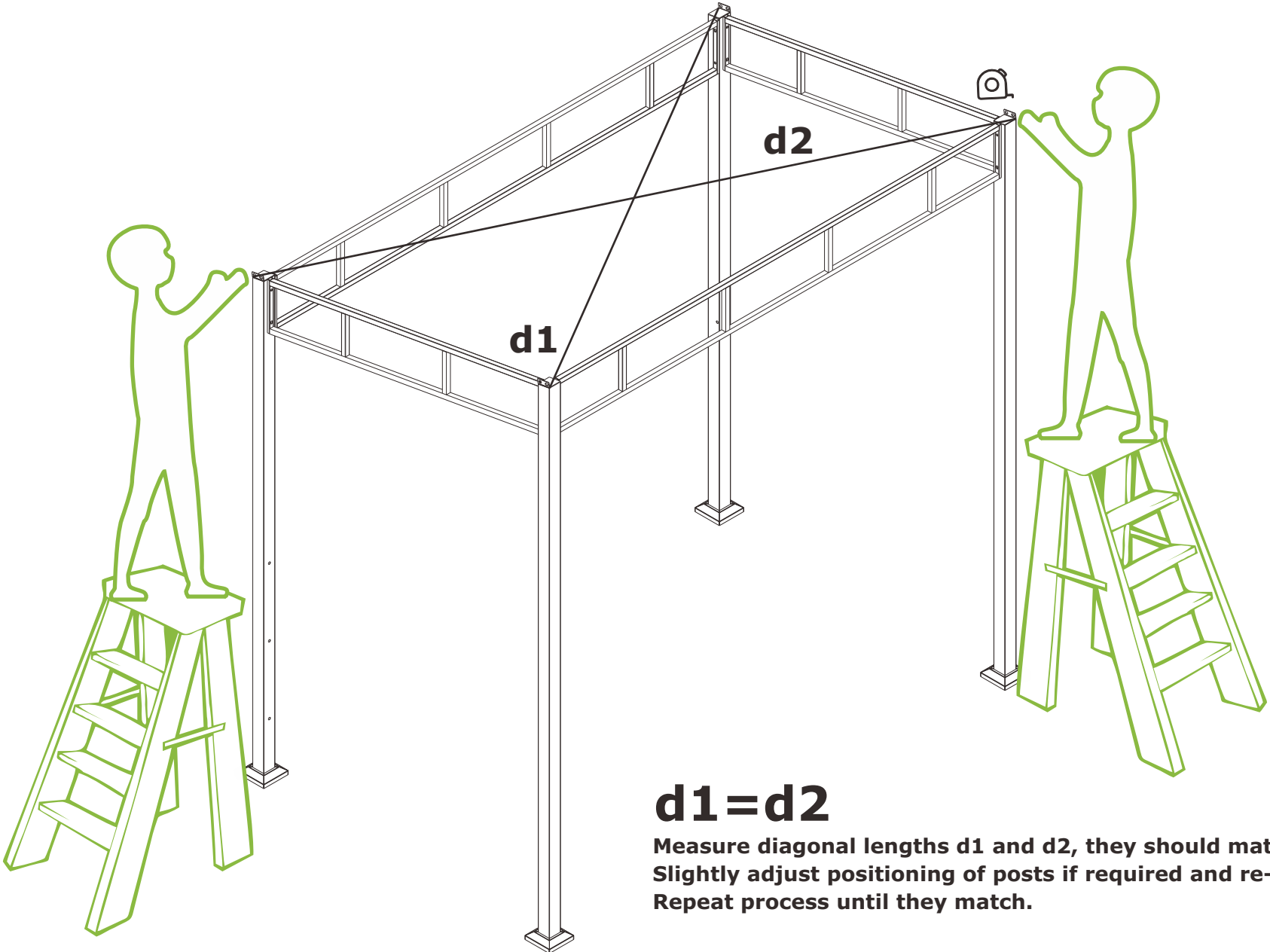

**d1 = d2**

Measure diagonal lengths d1 and d2, they should match. Slightly adjust positioning of posts if required and re-check. Repeat process until they match.

# Part 4

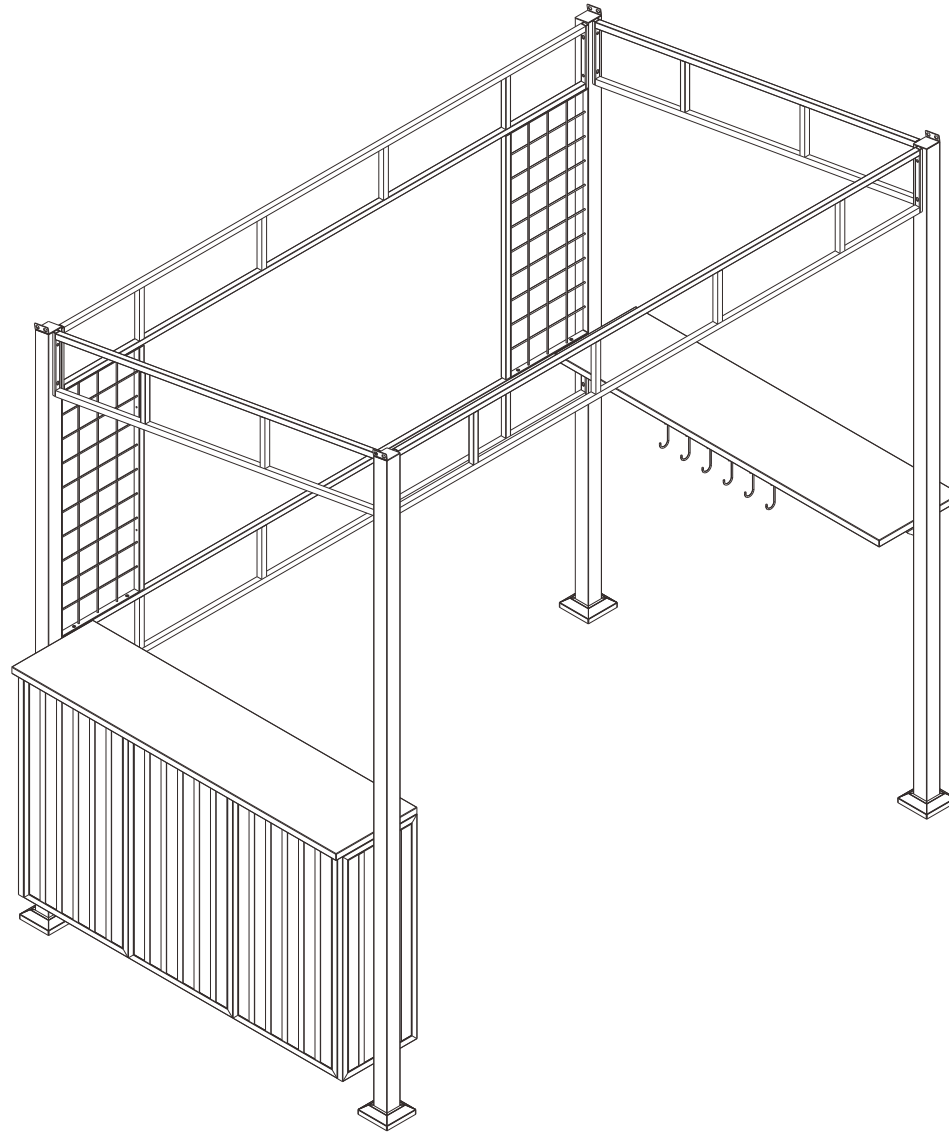

6

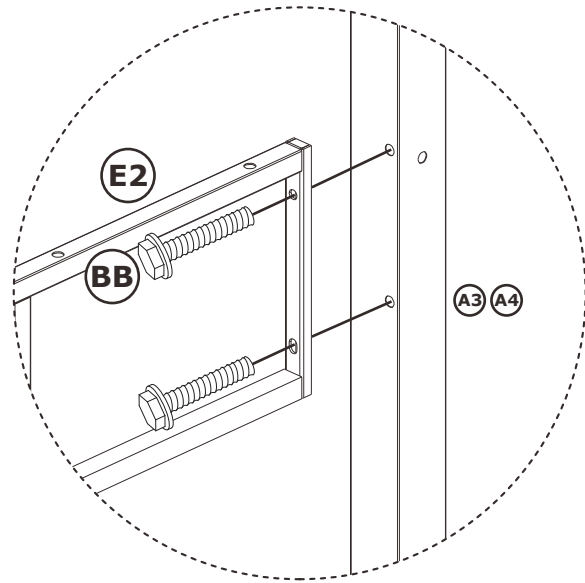
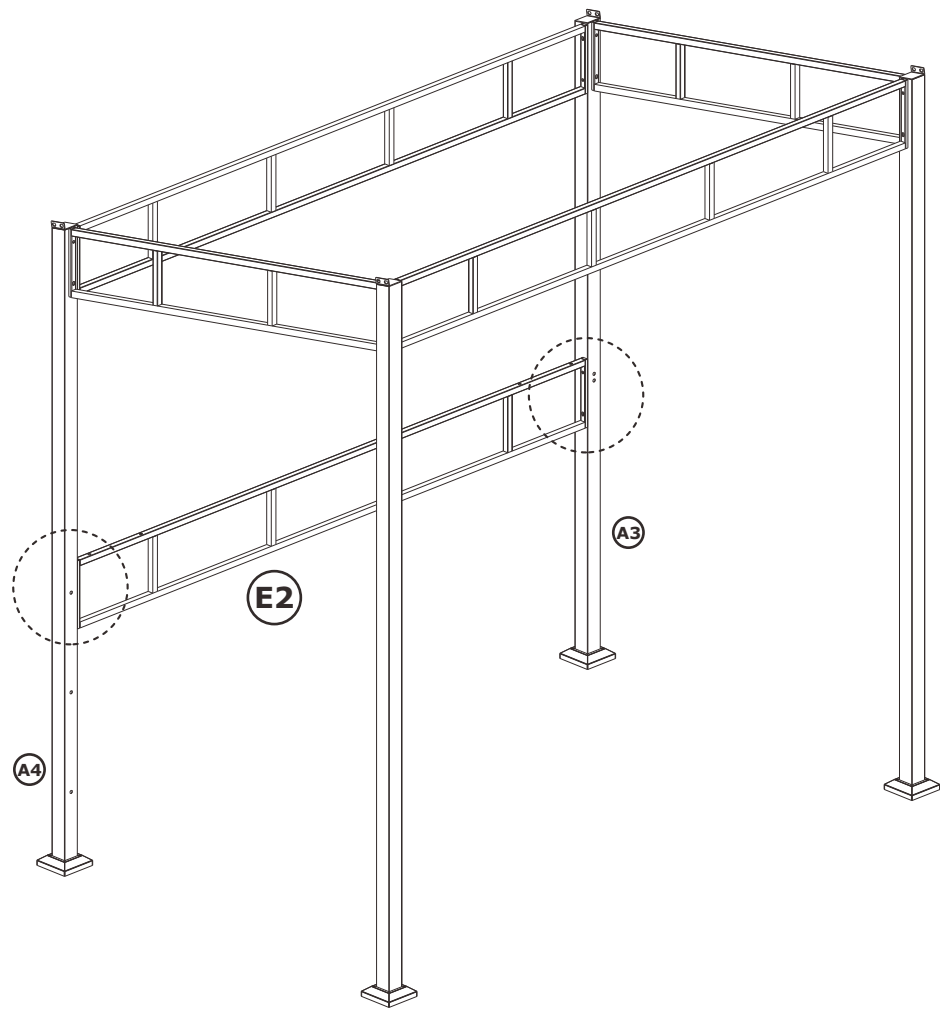

7

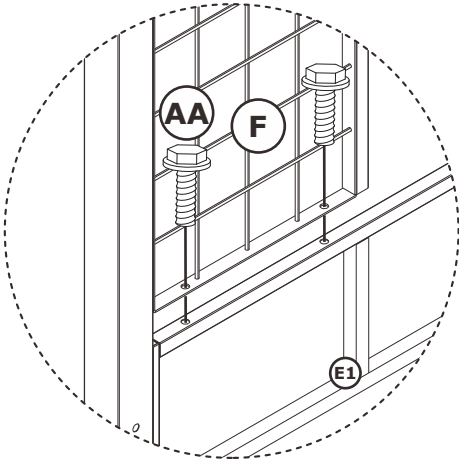
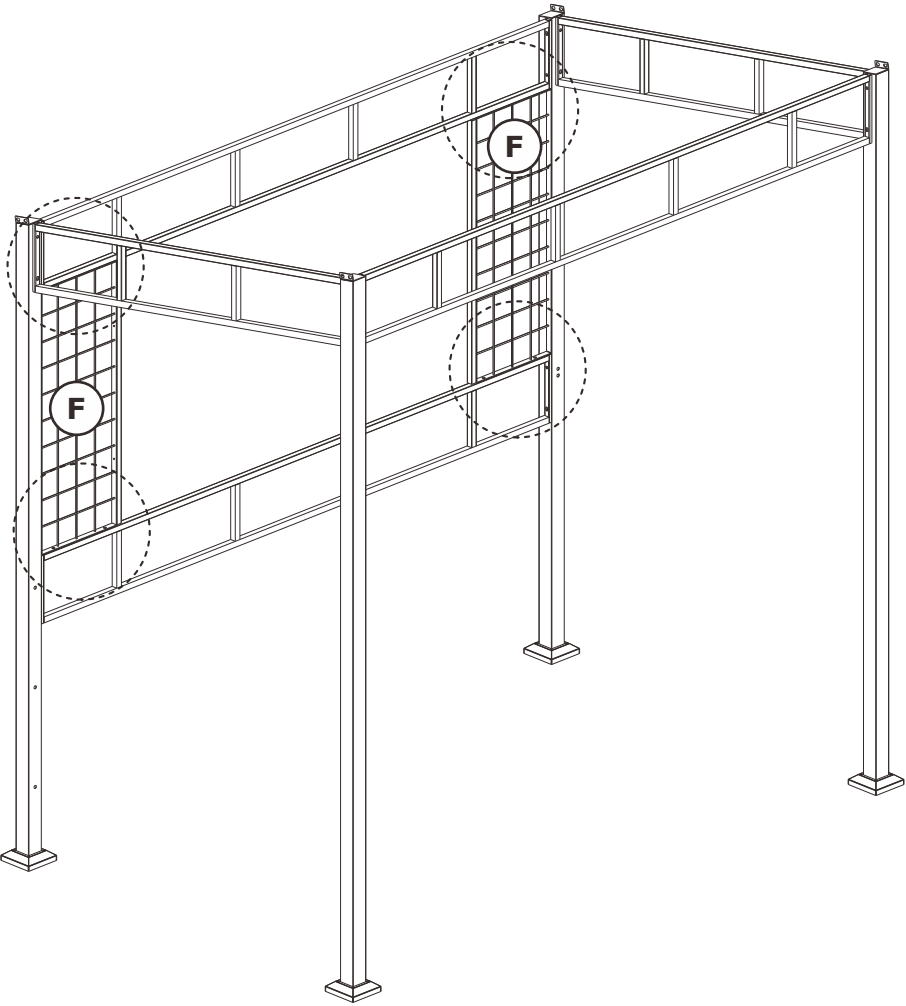

8

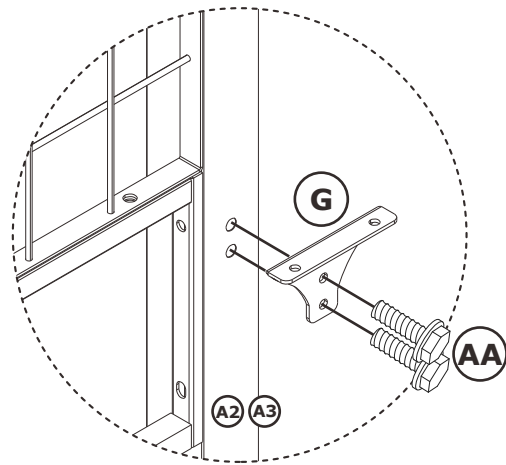
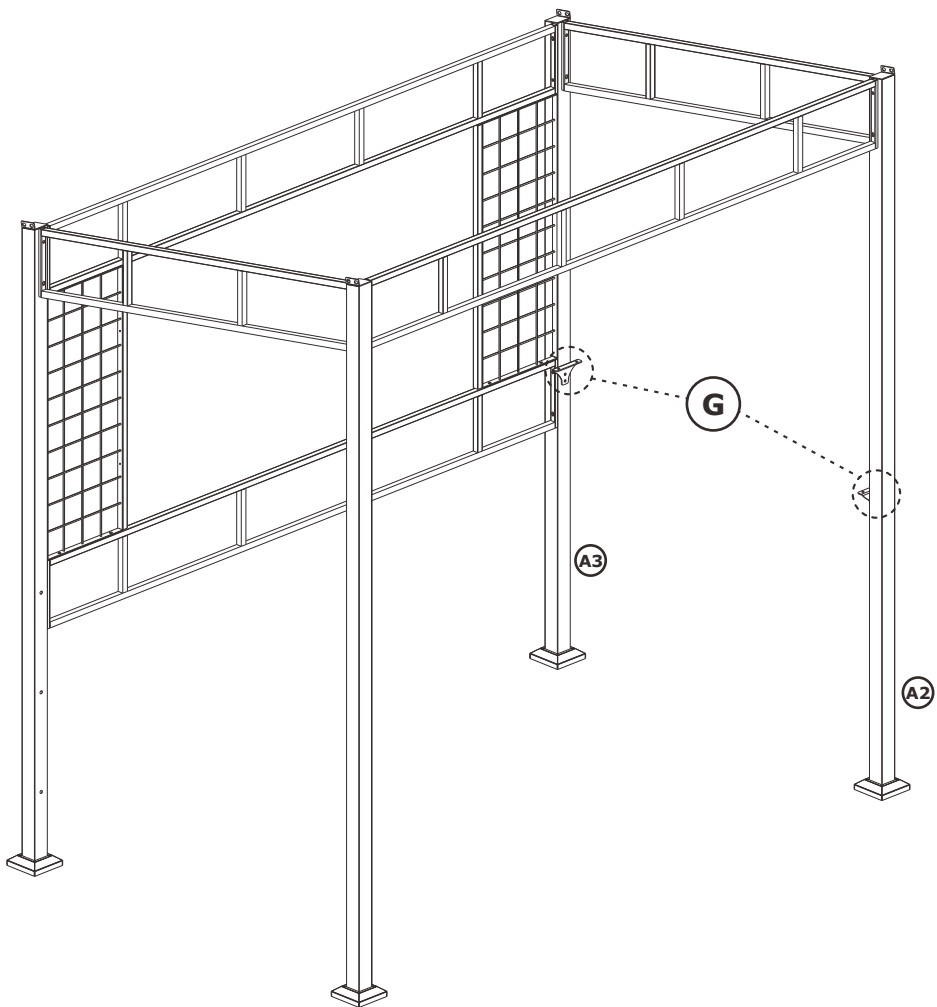
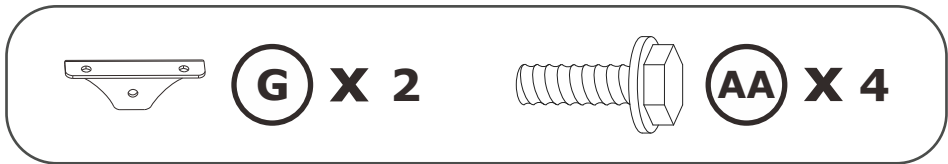

9

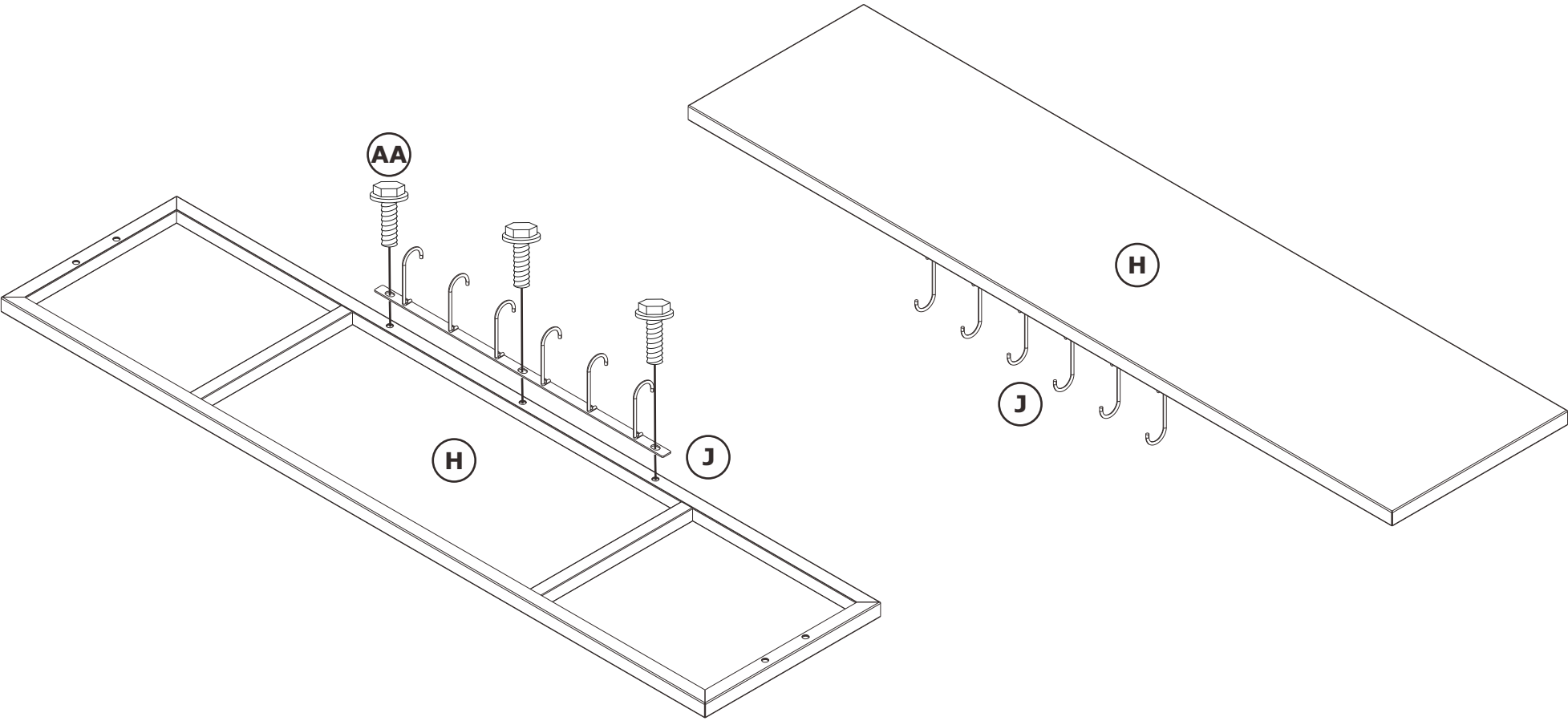
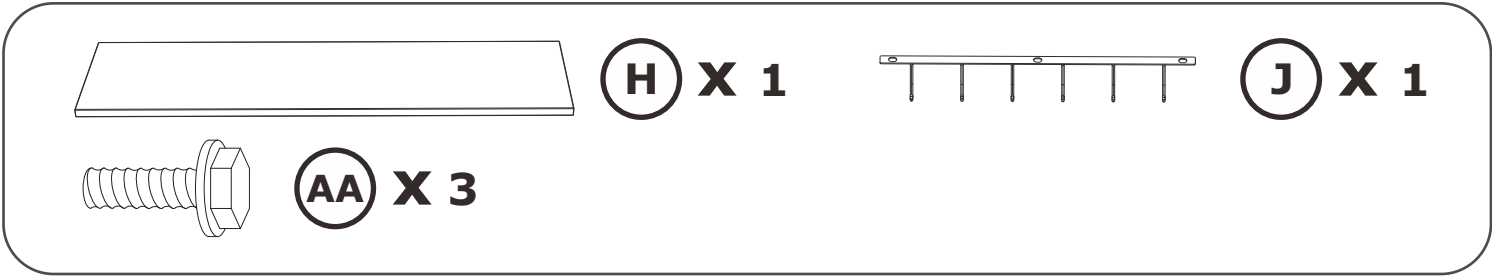

10

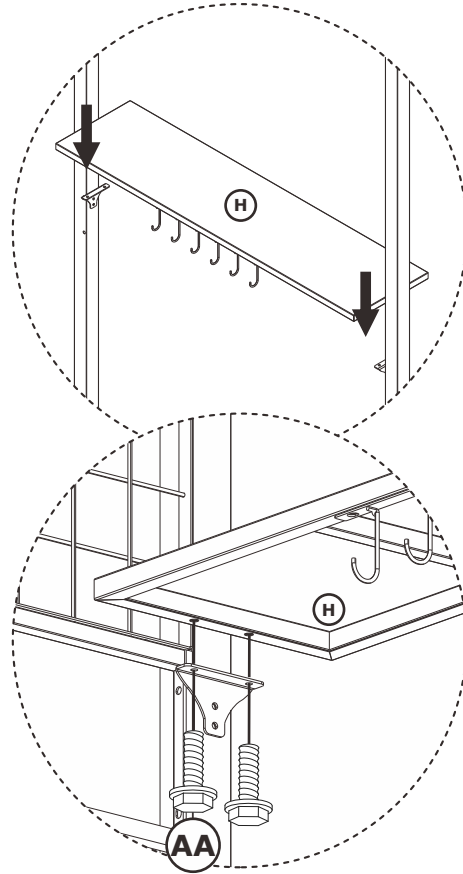
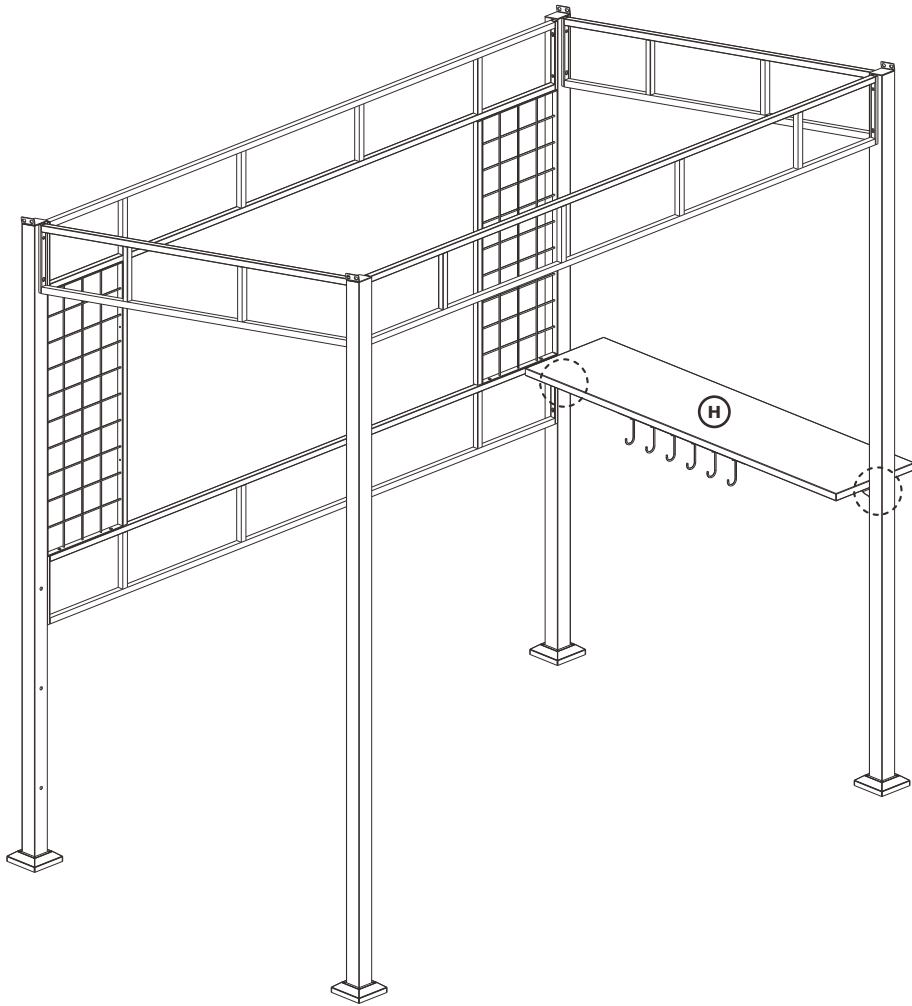
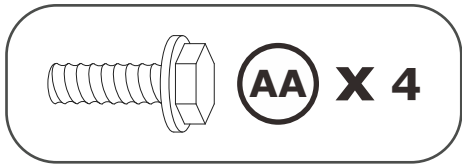

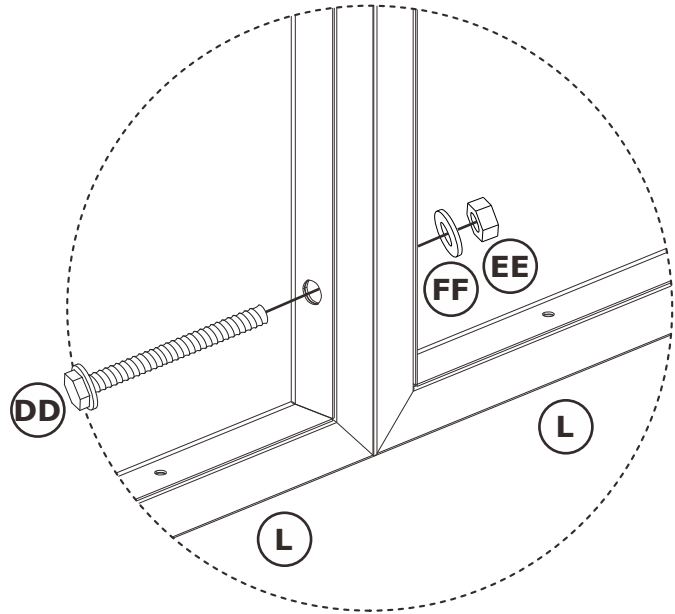
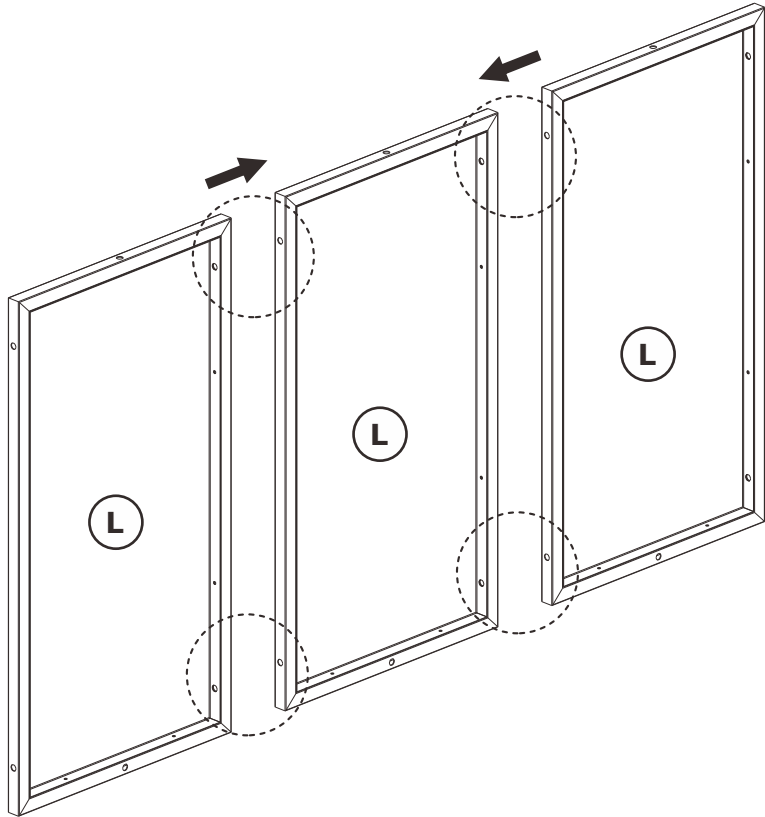
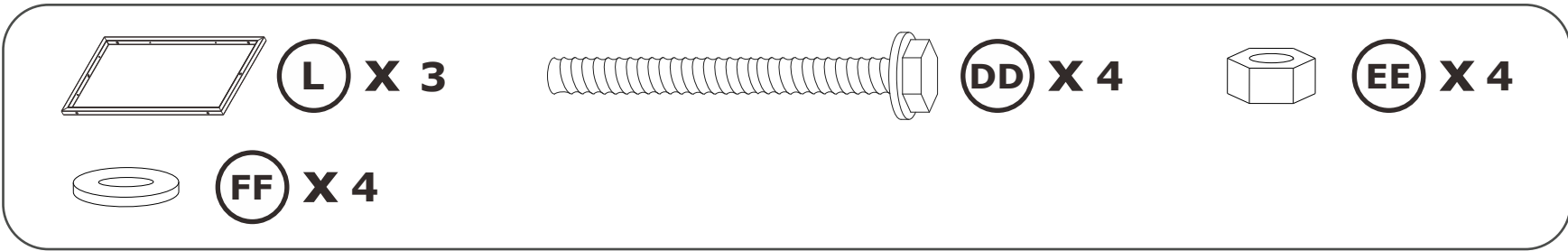

12

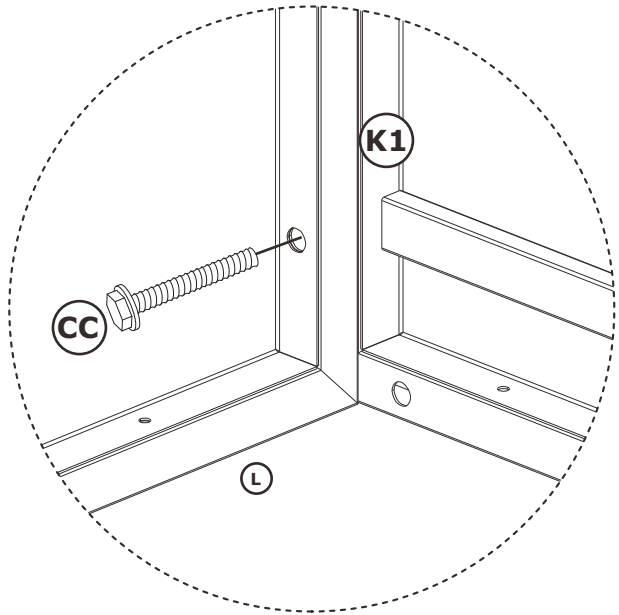
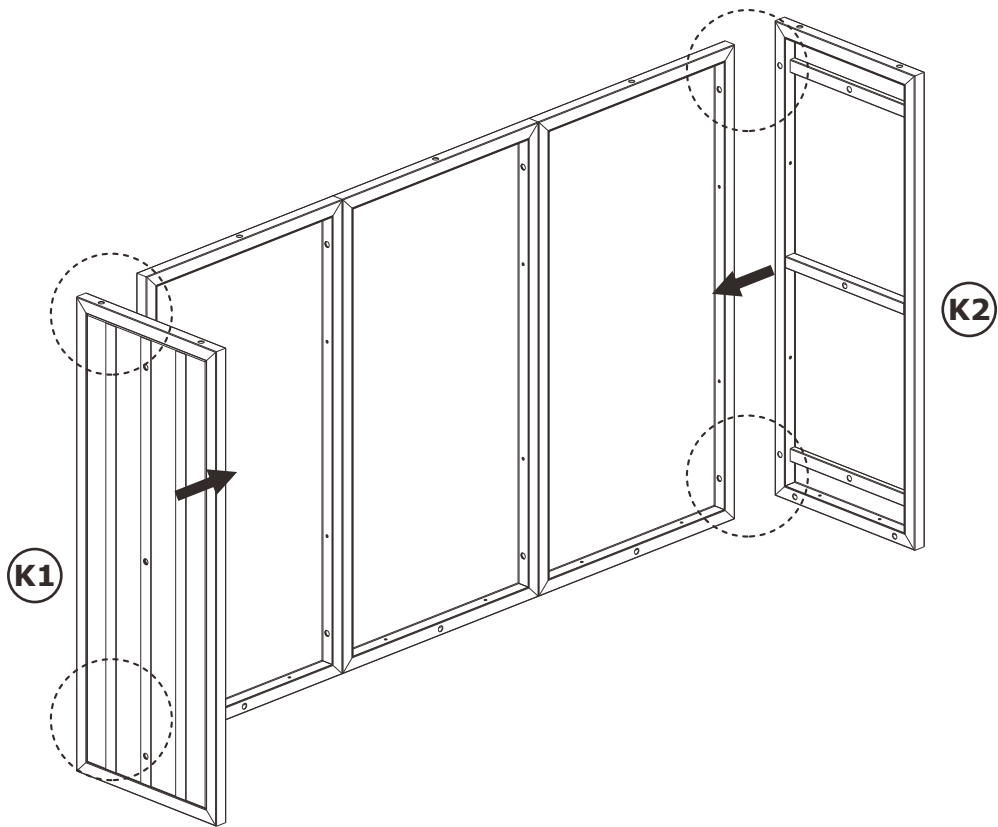

 **M X 1**       **BB X 7**

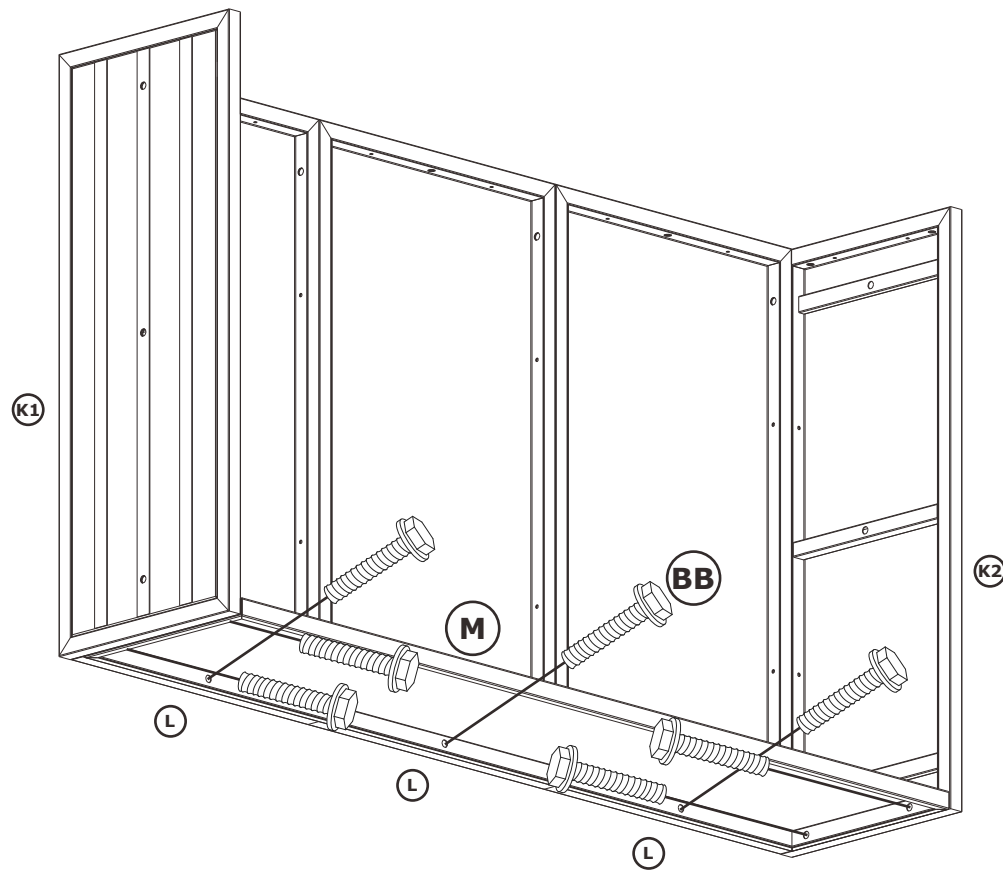
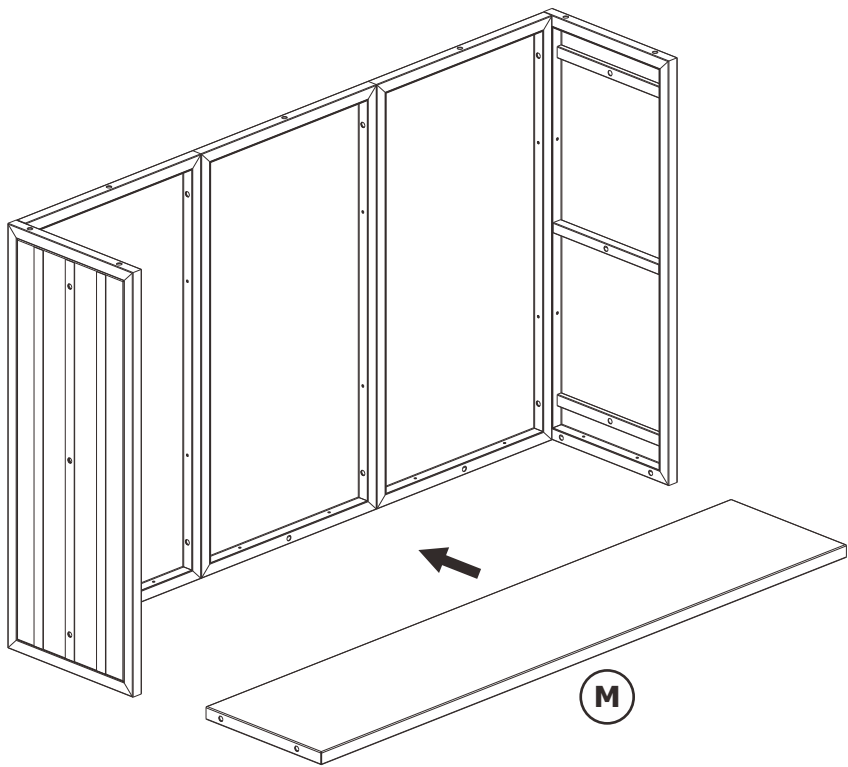

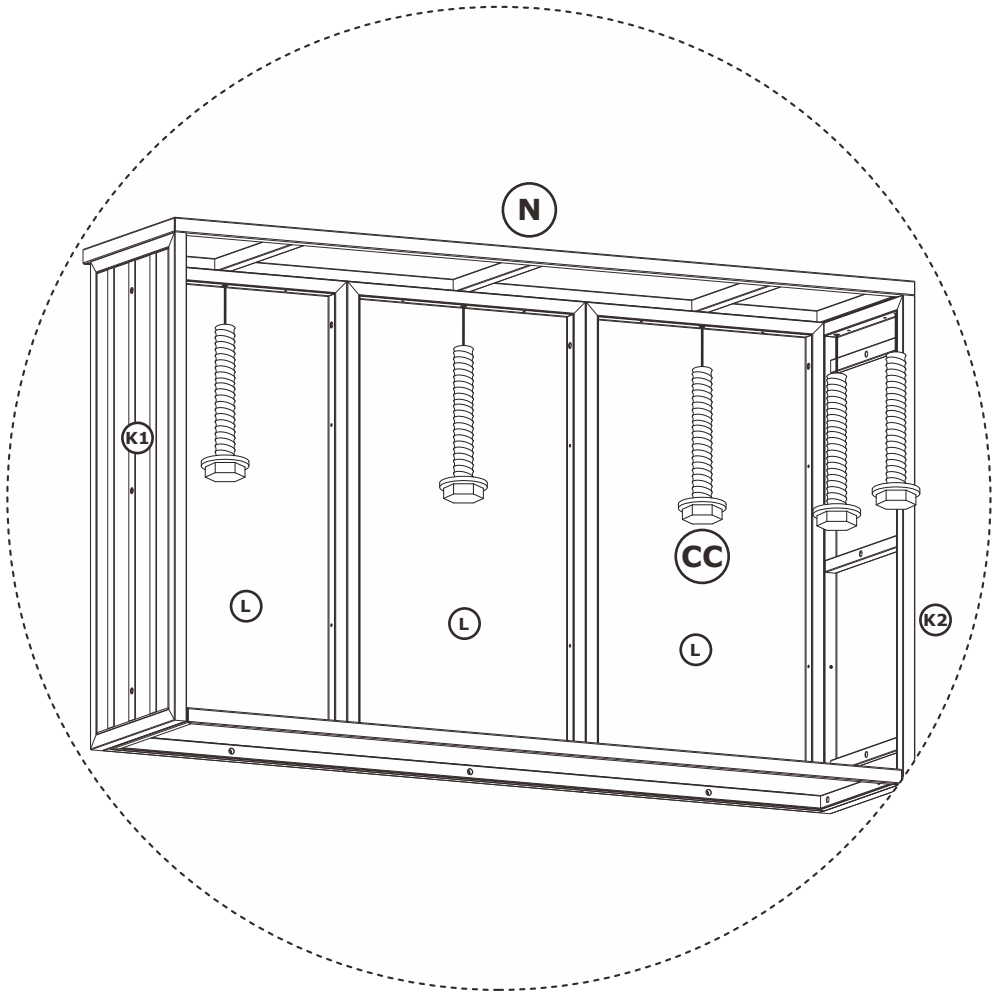
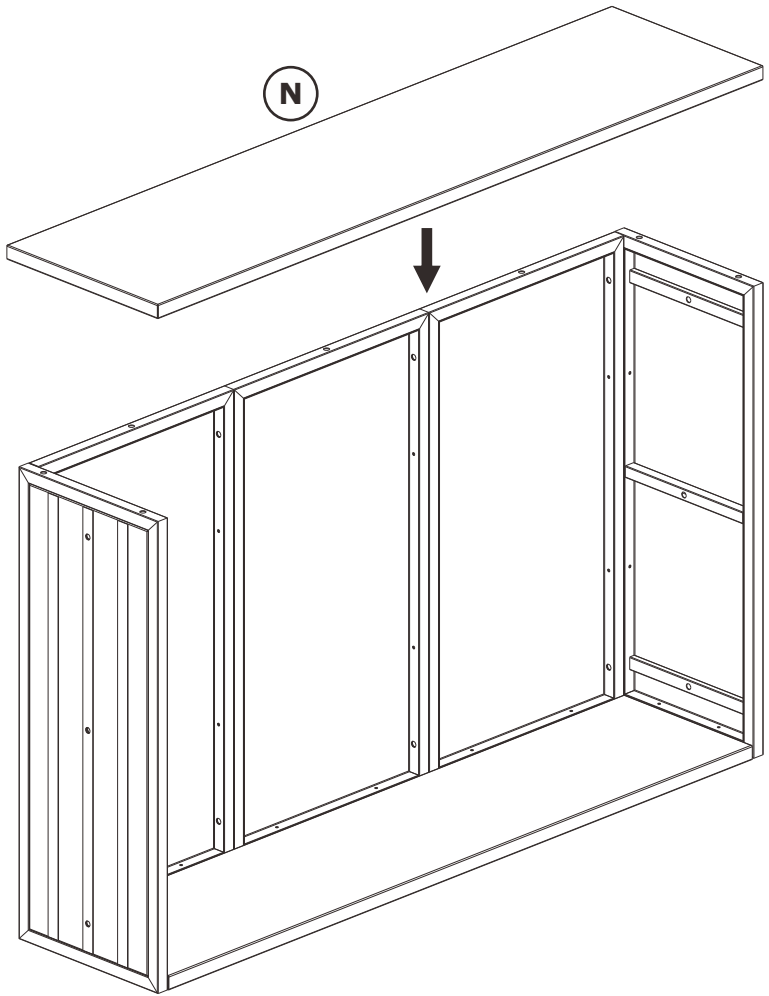
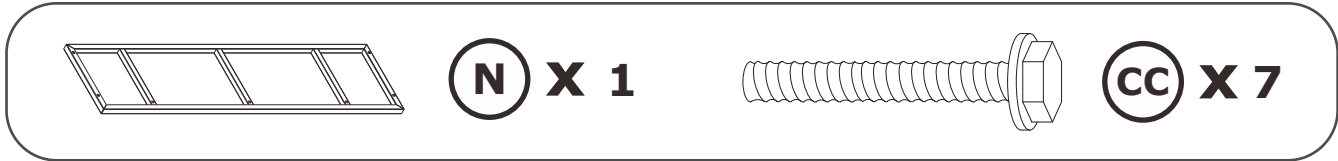

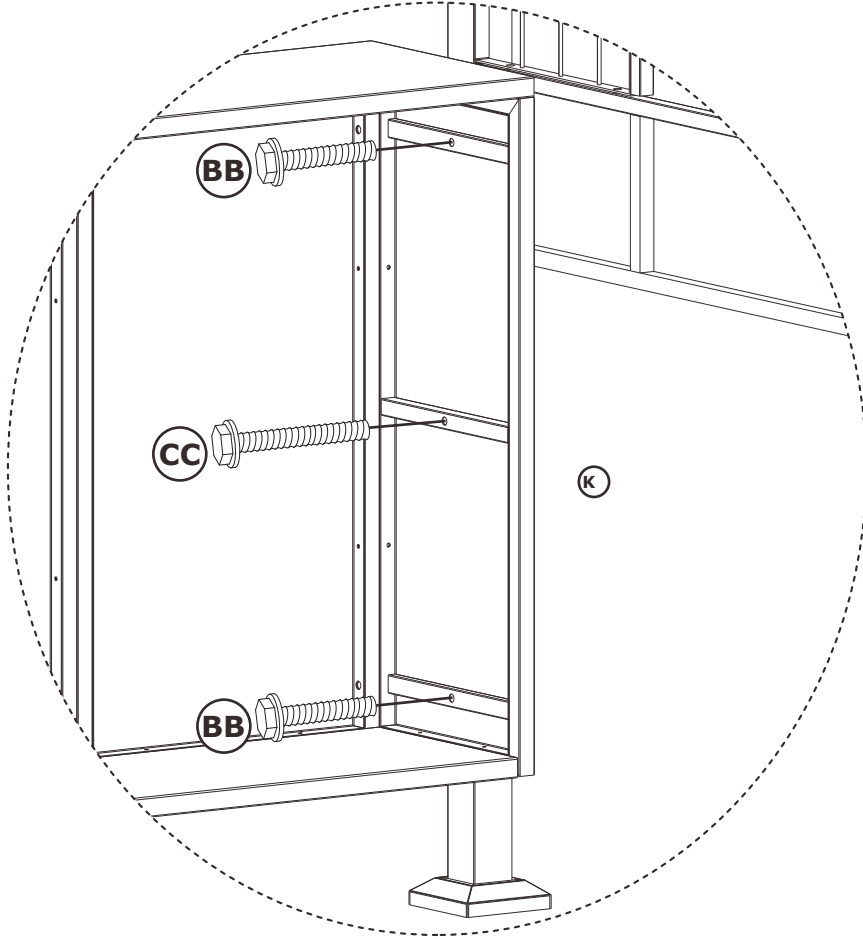
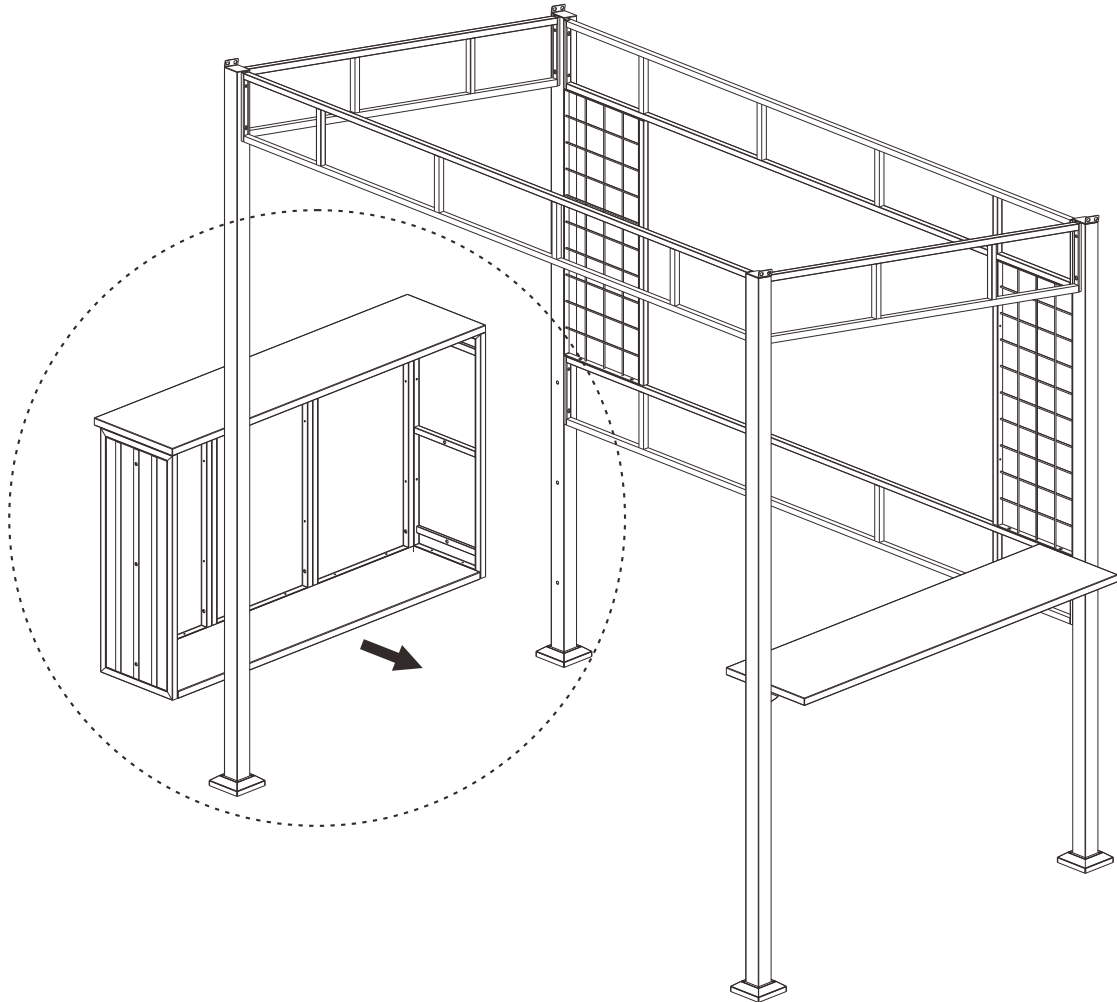
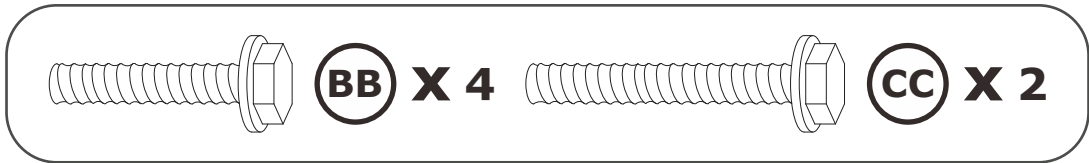

16

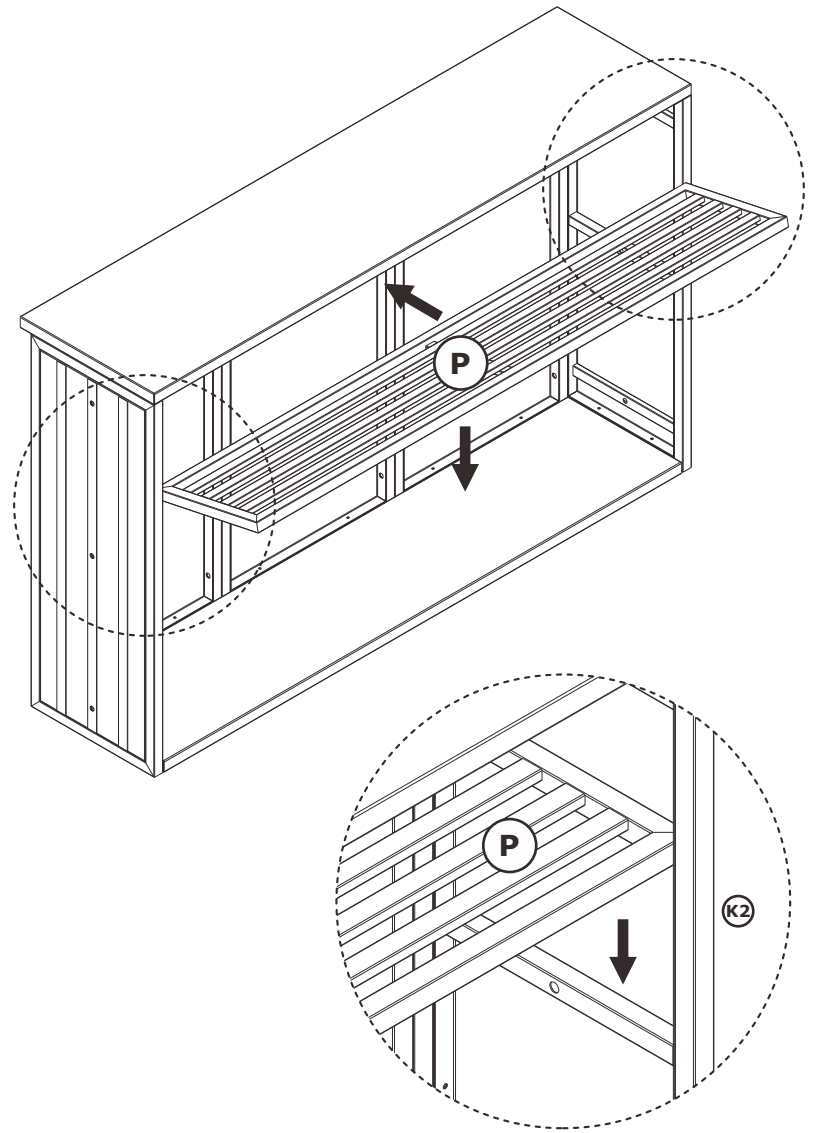
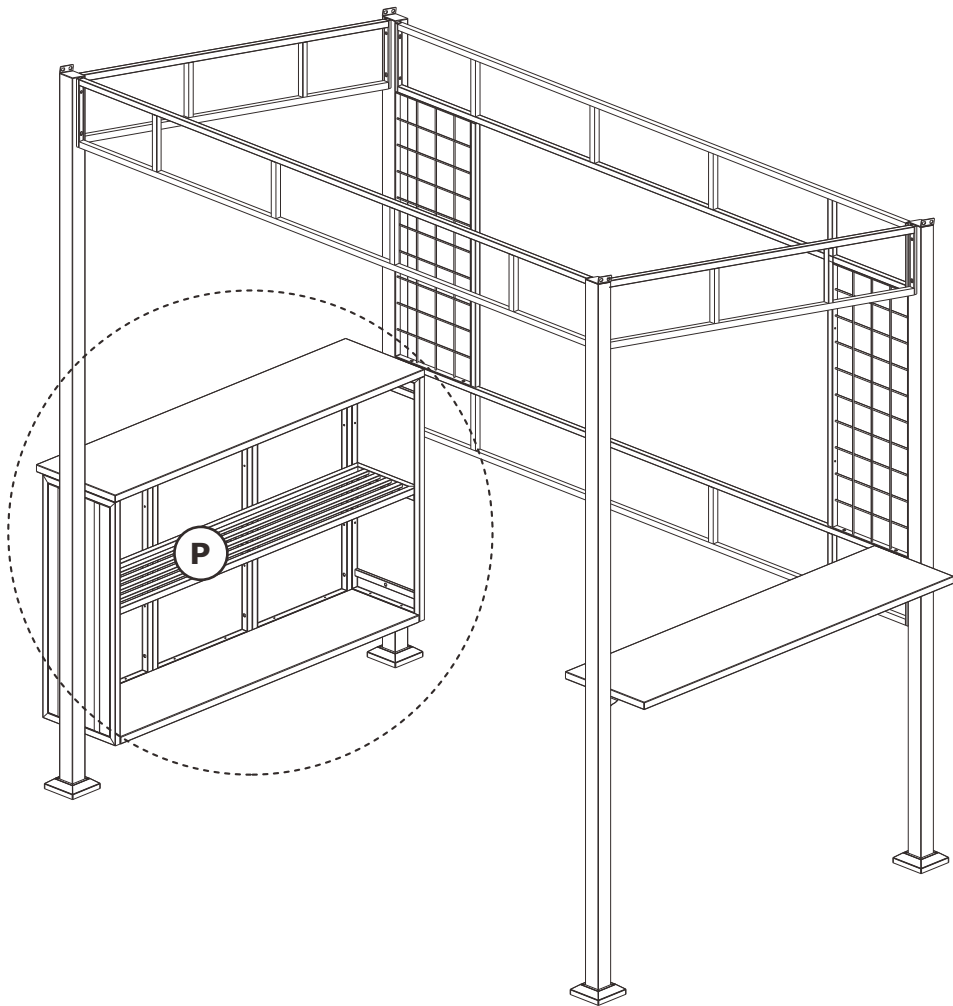
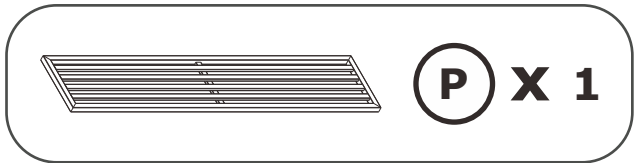

# Part 5

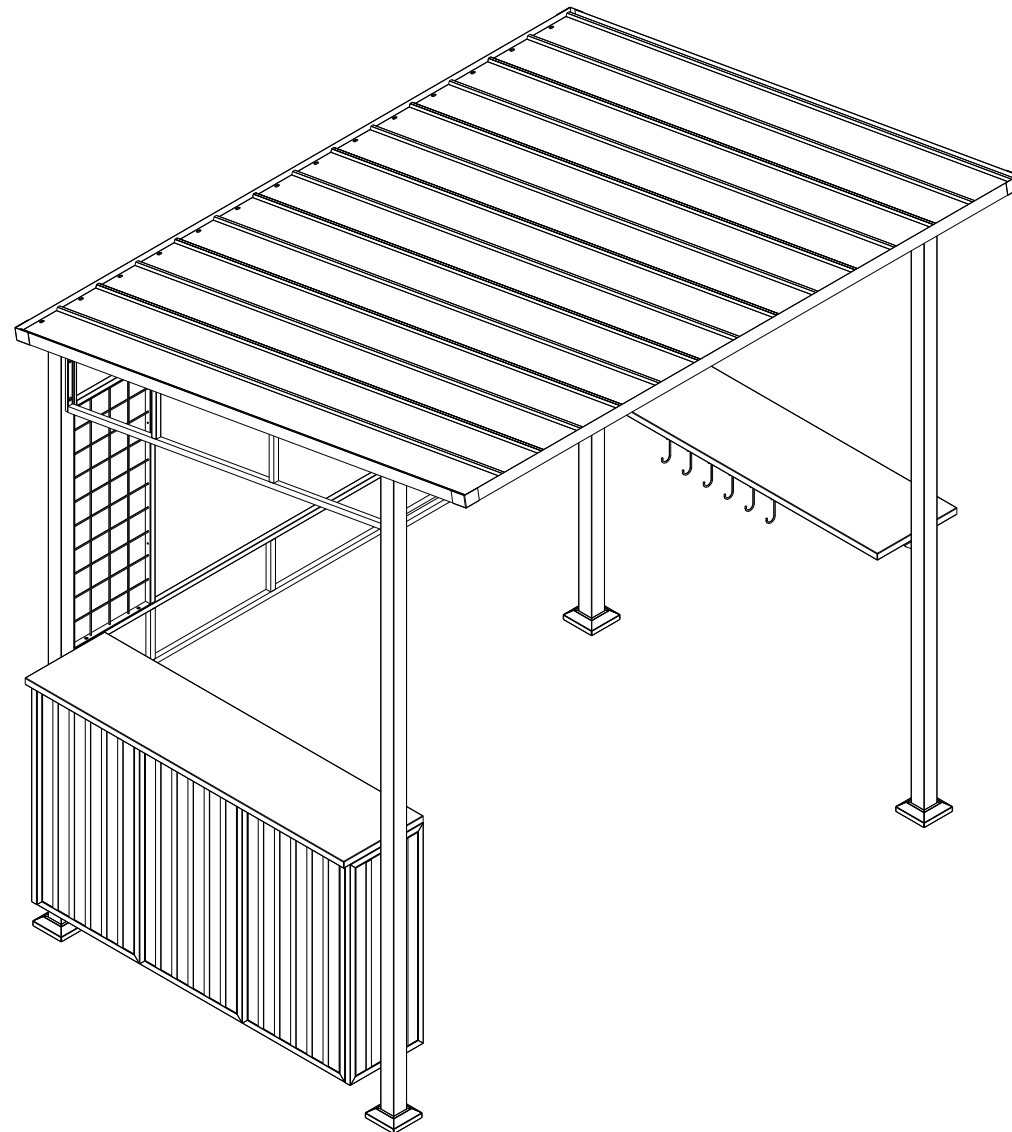

17

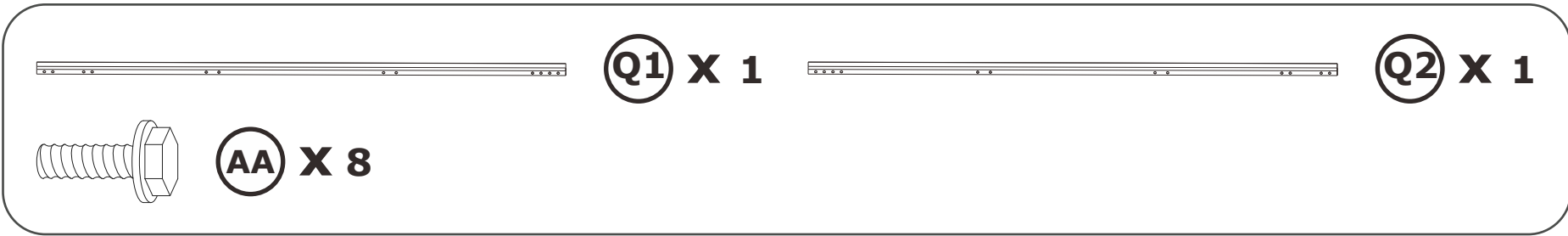

Q1 X 1

Q2 X 1

AA X 8

This block contains the parts list for step 17. It features three items: a long horizontal metal bar labeled Q1 X 1, a shorter horizontal metal bar labeled Q2 X 1, and a bolt with a hexagonal head labeled AA X 8. The items are arranged horizontally within a rounded rectangular frame.

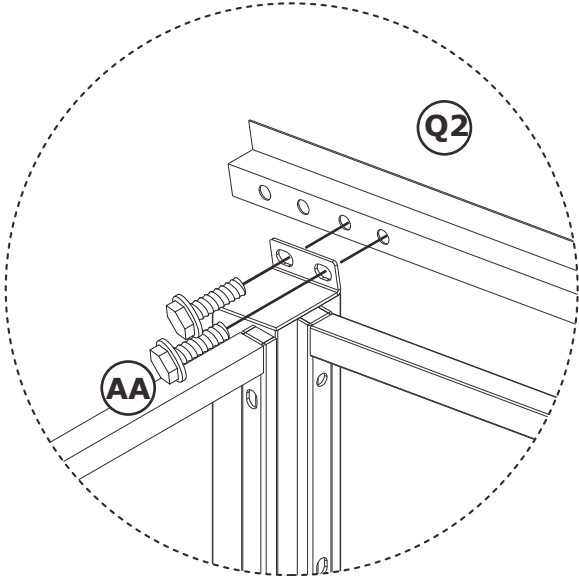
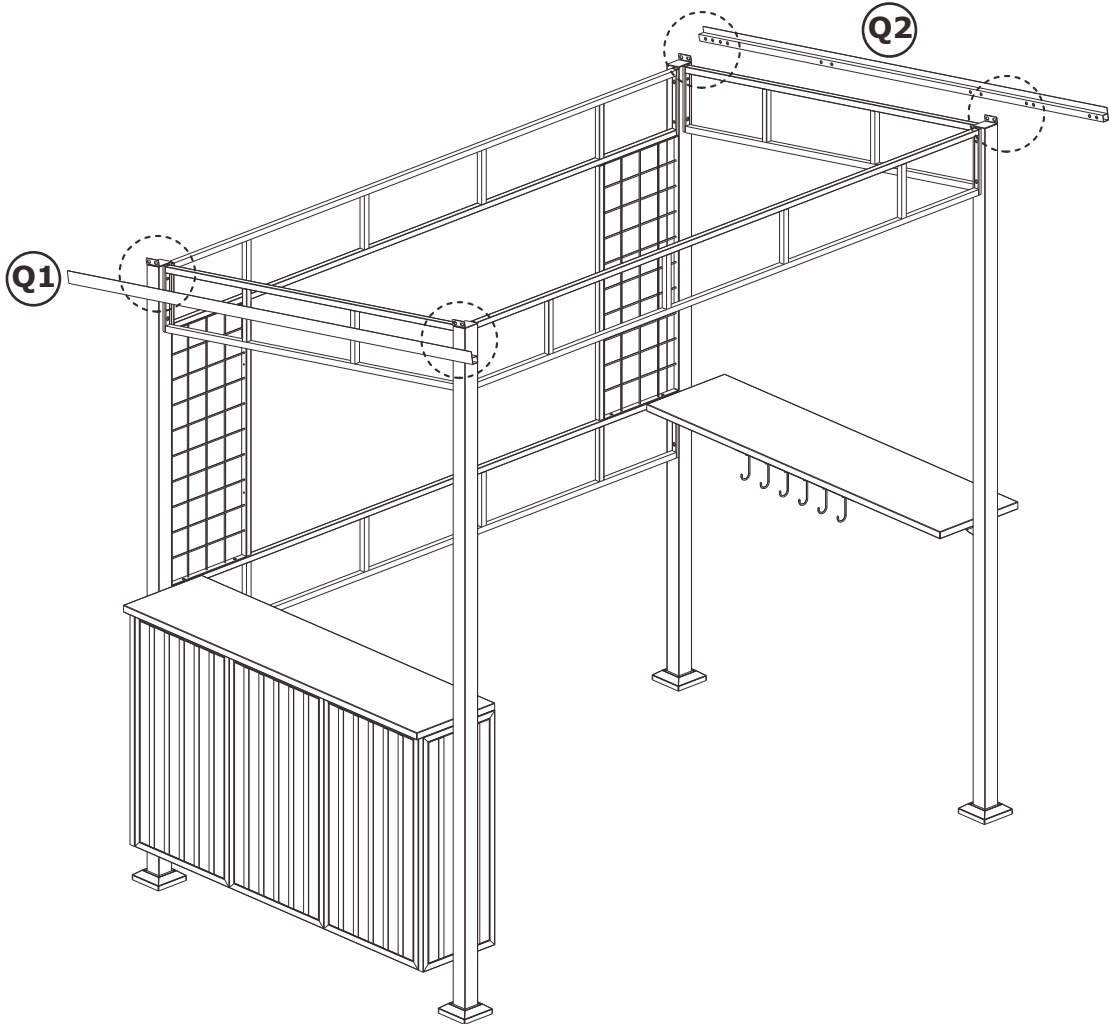

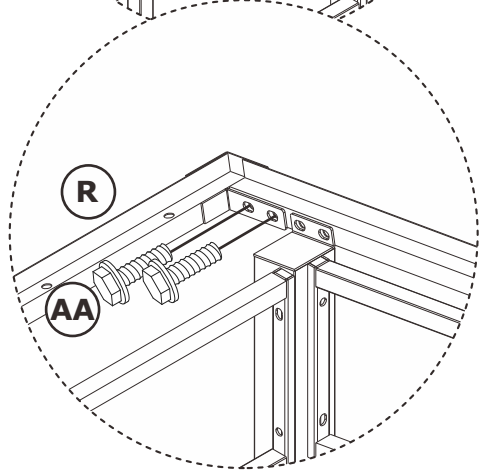
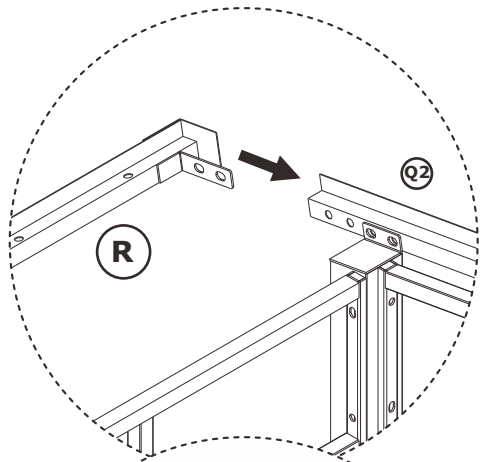
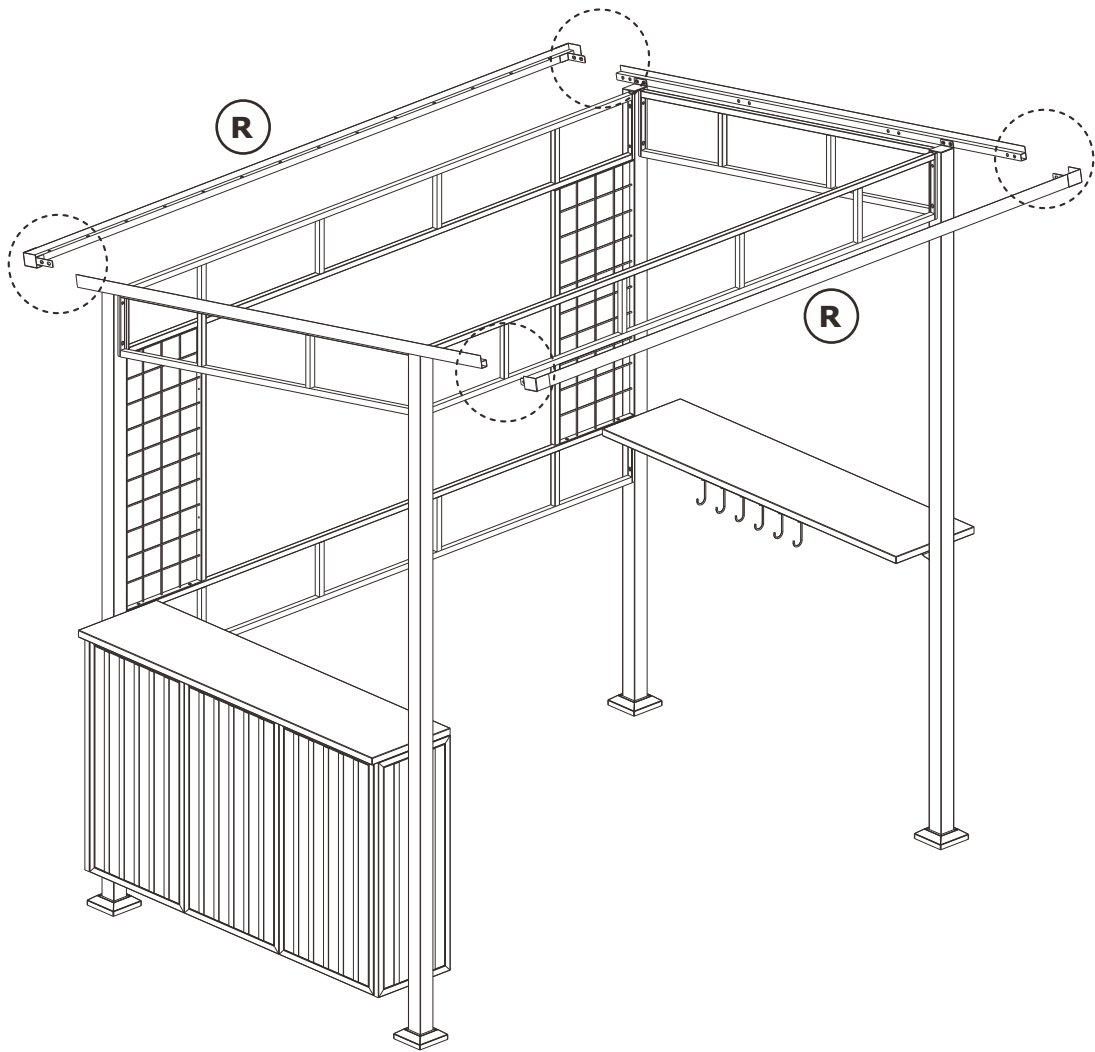
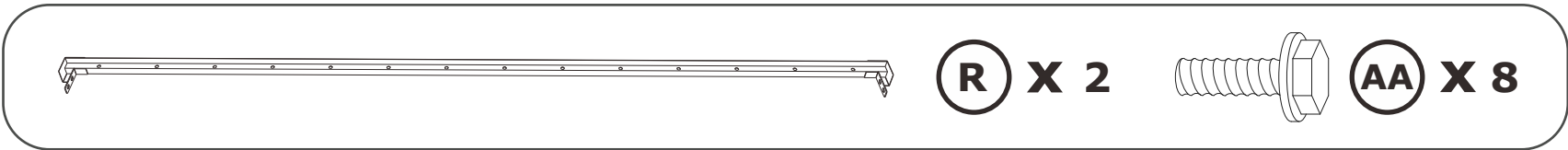

19

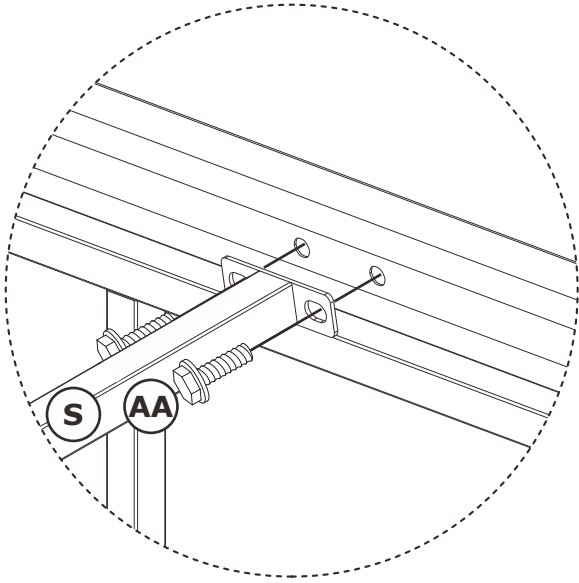
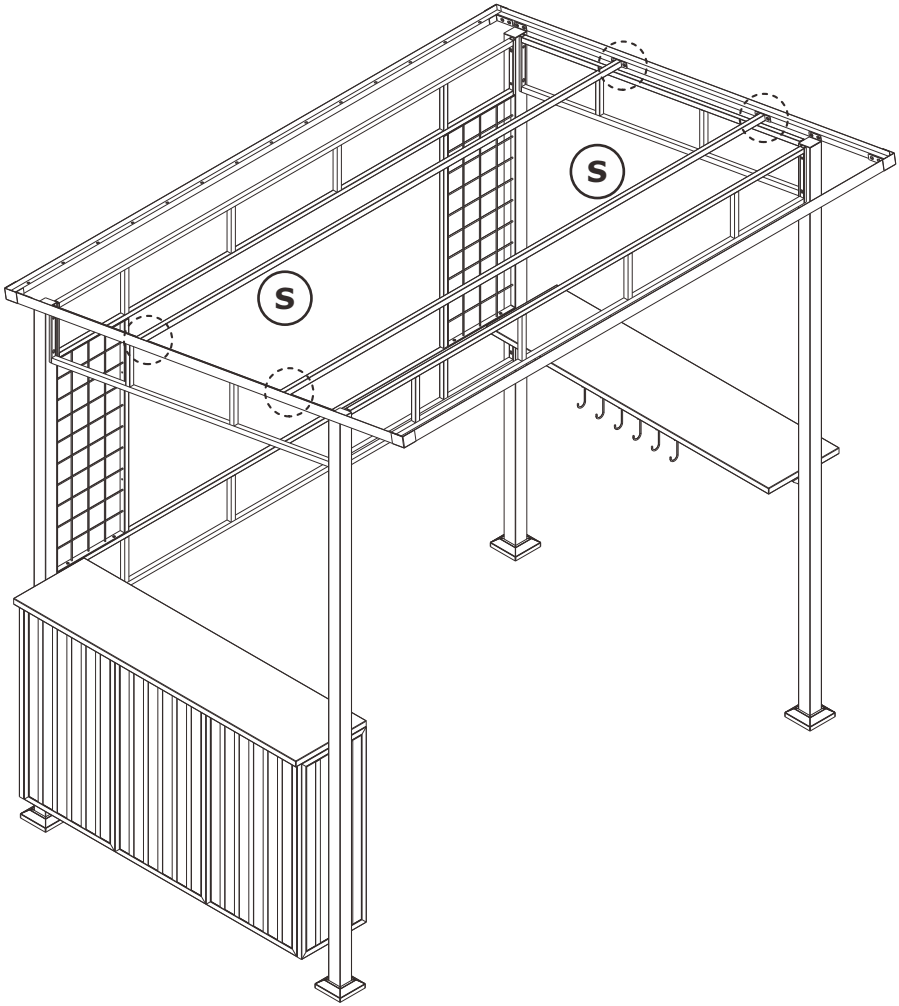
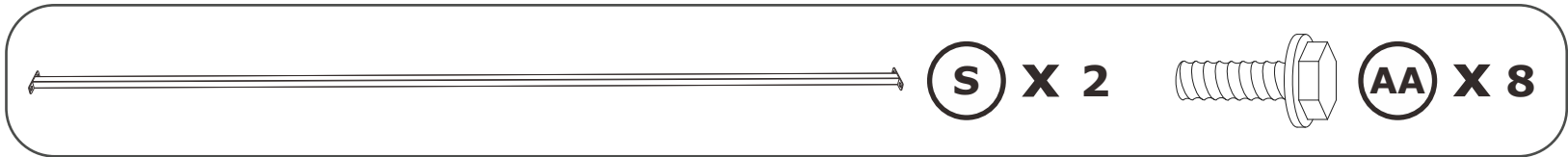

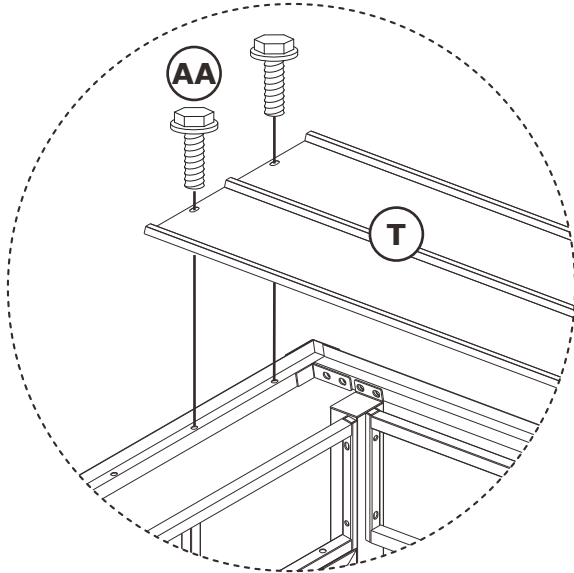
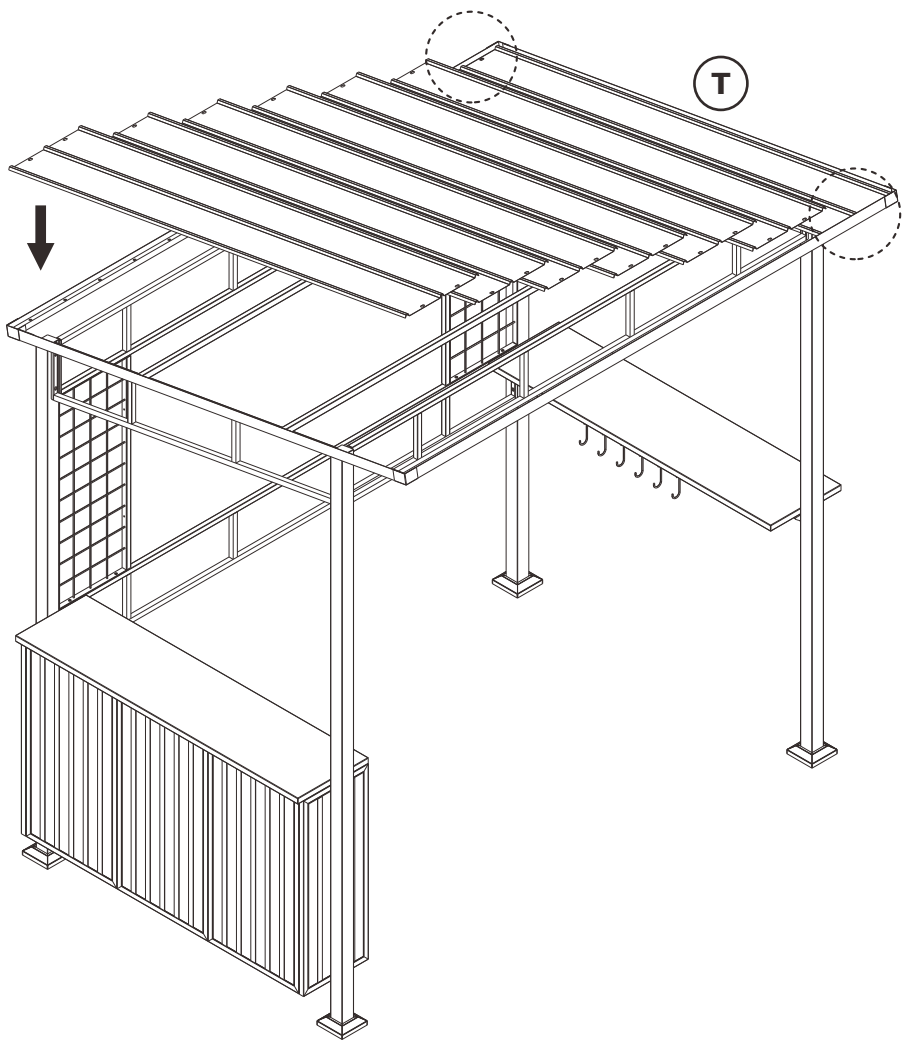
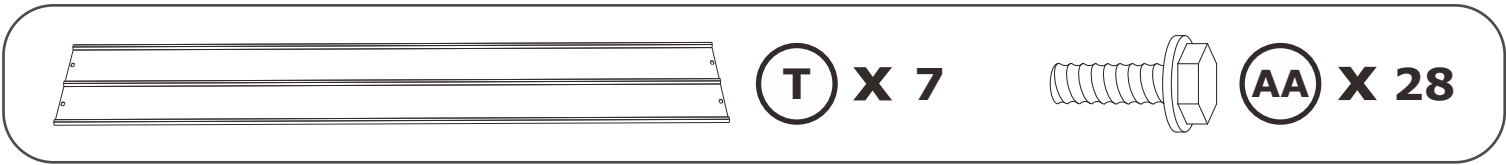



Must be secured to your surface using the appropriate fixings

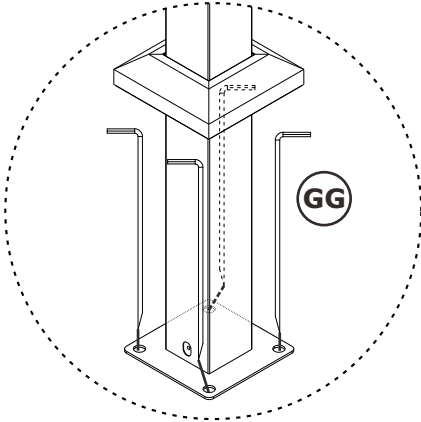
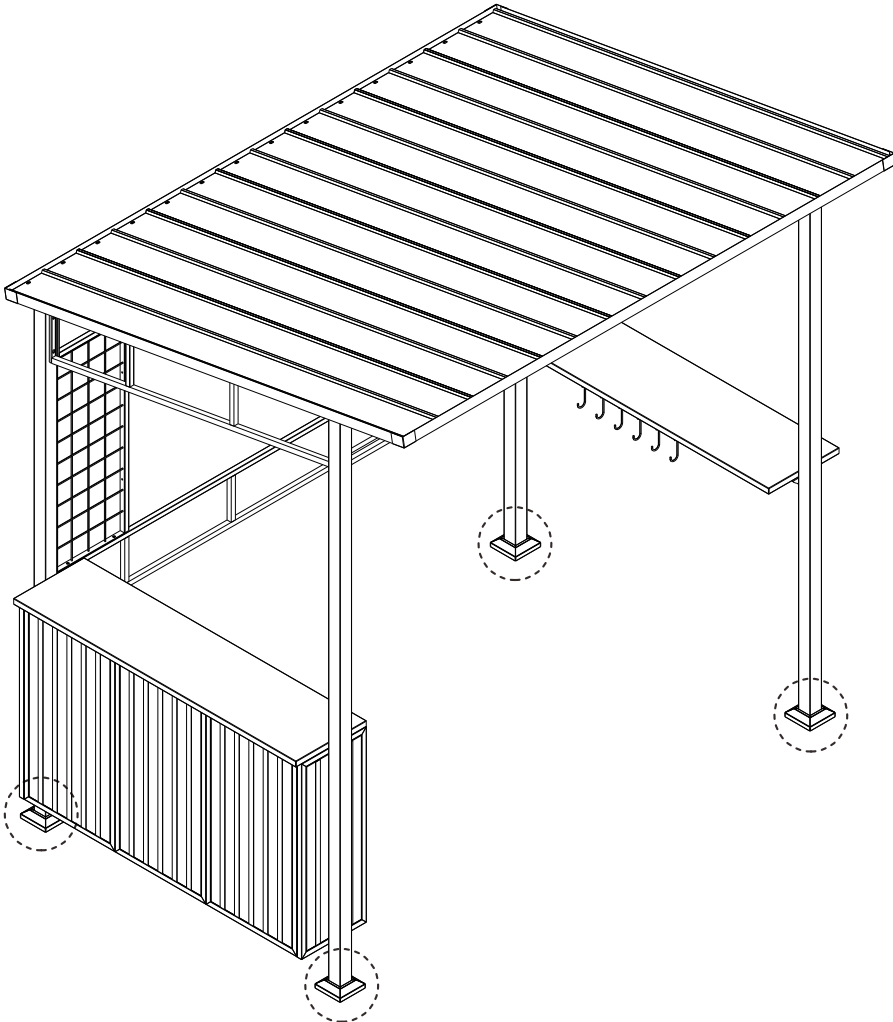

SOFT GROUND

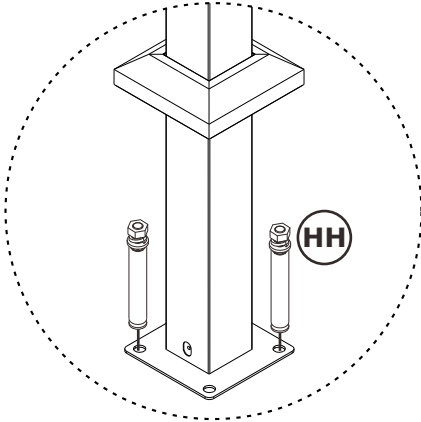

HARD GROUND

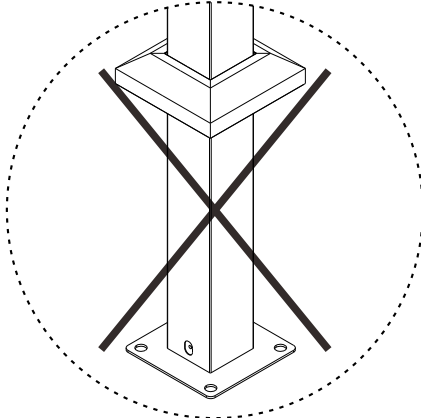

# HELP CENTRE

## QUALITY COMMITMENT & RETURN POLICY

If you experience any concerns with your purchase, please contact our customer service team before initiating a return.

We're committed to finding a solution that ensures your satisfaction.

**Important:** Please retain original packaging until assembly is complete and you're satisfied with the product quality.

### Return Period:

- 30-day return window from purchase date
- One-year warranty on all purchases

### Return Shipping Coverage:

#### We Cover Shipping When:

1. Manufacturing defects are present (damaged materials, misaligned parts)
2. Items arrive damaged during transit
3. Incorrect items shipped due to warehouse error
4. Partial order loss during shipping

#### Customer Covers Shipping When:

1. Change of mind after delivery
2. Product no longer needed
3. Ordering mistake
4. Failed cancellation attempts after delivery

**Note:** Our customer service team is here to help find the best solution for your situation. Please contact us to discuss your concerns before proceeding with a return.

**All returns require photo documentation for processing.**

### Contact us at

✉ [service@grdnliving.co.uk](mailto:service@grdnliving.co.uk)

GRDN living (a trading name of The Breeze Group Limited)  
16 Hennals Ave, Redditch B97 5RX, United Kingdom  
[www.grdnliving.co.uk](http://www.grdnliving.co.uk)

## RETURN REQUEST GUIDELINES

### Requirements for Full Refund:

#### 1. Item Condition

- Must be brand new/unused if opened
- Photos required before and after packaging

#### 2. Packaging

- All accessories and parts must be included
- Use original packaging materials
- Secure packing required

#### Refund Process:

- Refund issued after items arrive at our warehouse
- Incomplete/improper returns may result in partial refund

### Beyond Return Period:

- If your product shows damage or defects outside the standard return window, please email us
- We value your satisfaction and will work with you to find an appropriate solution

### Warranty Information:

- Warranty claims cannot be accepted without proof of purchase
- Warranties are valid from the date of delivery to the original purchaser only
- Warranty terms can be found at <https://warranty.grdnliving.co.uk/>
- The warranty applies to residential domestic use within the UK only
- It does not cover commercial use, misuse, accidental damage or normal wear and tear
- We reserve the right to repair and/or replace parts rather than a complete item at our discretion