



150 KG Capacity Floor Lift | GBTS025 Operator's Manual



Warning: Please read and thoroughly understand all instructions before operating. Failure to follow safety rules and other basic safety precautions may result in serious personal injury. Keep these instructions in a safe and easily accessible place so that they can be referred to when needed. Retain these instructions to assist in future servicing.

1. SAFETY INTRODUCTION	1
2. TECHNICAL SPECIFICATIONS	1
3. COMPONENTS	2
4. KNOW YOUR MACHINE	3
5. ASSEMBLY	4-5
6. OPERATION	5-6
7. MAINTENANCE & STORAGE	6
8. WARRANTY	6

1. SAFETY INSTRUCTION

Prior to operating the floor lift, evaluate whether the user is appropriate for the device by considering aspects like weight, size, mental capacity and joint movement.

Persons with disabilities should either have assistance nearby or be within reach of alarm devices during use.

▲WARNING

1. DO NOT EXCEED the maximum weight capacity.
2. Please sit steadily on the floor lift and ensure the surrounding area is safe before use.
3. Do not use the floor lift on excessively sloped surfaces (more than 3 degrees) or on surfaces with steps.
4. Do not stand on the floor lift.
5. Do not use if any parts are missing.
6. Do not allow children to use this equipment.
7. Do not place the floor lift in overly hot areas, as it contains batteries.
8. When not in use for a long time, fully charge the battery before storing to prolong its life.

2. TECHNICAL SPECIFICATIONS

Model	GBTS025
Max. lifting capacity	150 kg (330 lb)
Lifting height	500 mm (20 in.)

Linear Actuator	
Max. load	2000 N
Lifting speed	9 mm/s (0.35 in./s)
Rated voltage	24 Vdc
Duty cycle	10%, 6 min/60 min
IP code	IP68

Battery	
Max. output voltage	25.9 Vdc
Capacity	2000 mAh

Charger	
Input	100-240 Vac, 50/60 Hz, 1.2 A
Output	29.4 Vdc, 1 A

3. COMPONENTS

The floor lift comes partially assembled and is shipped in carefully packed carton. After all the parts have been removed from the carton, you should have:

 <p>A grey plastic floor lift machine body, partially assembled, showing the base and the raised backrest section. It has several circular holes on the backrest and a black cable attached to the bottom.</p>	 <p>Two identical grey plastic side wings, each with a central handle cutout and a small protrusion at the bottom.</p>
 <p>A white wired remote control with a coiled cable. The remote has a circular button at the top, two triangular buttons (up and down), and a rectangular button at the bottom.</p>	 <p>A black power adapter with a three-pronged AC plug and a black cable ending in a connector for the machine.</p>

Machine Body * 1

Side Wings*2

Wired Remote*1

Charger*1

4. KNOW YOUR MACHINE

Understanding the structure and components of your Portable Floor Lift will help you understand and use it correctly and safely.

⚠️ WARNING

Casters are only used to move the machine, not to transfer people.

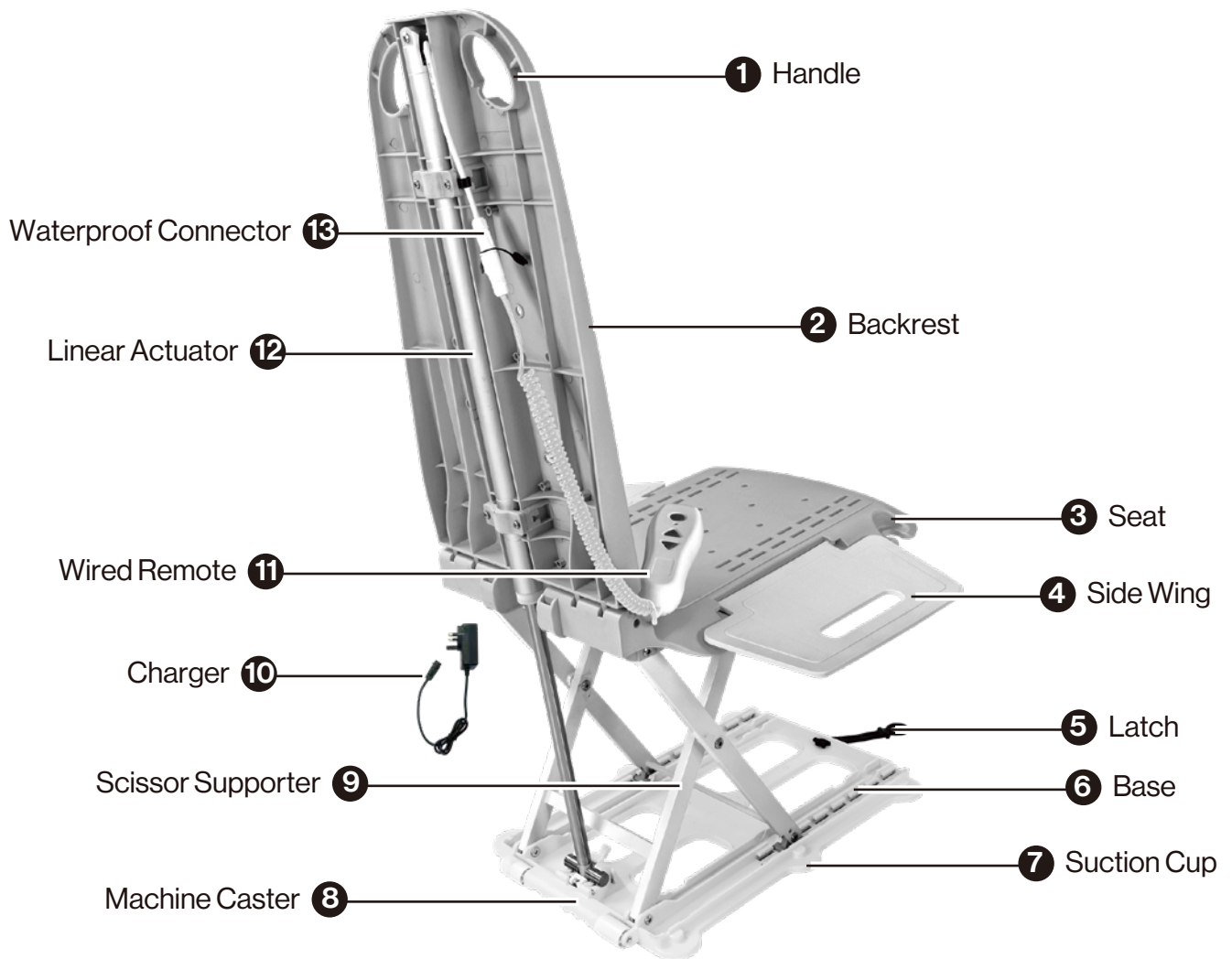

5. ASSEMBLY

This Portable Floor Lift requires minimal assembly. Please refer to the graphic guidance as follows.

Wired Remote connection (See Fig.01)



Side Wings assembly(See Fig.02-03)

If you think you don't need this assistance, you can choose not to install them or uninstall them.

NOTE: Side wing can help you move your body onto the seat more easily.(See Fig.02-03)

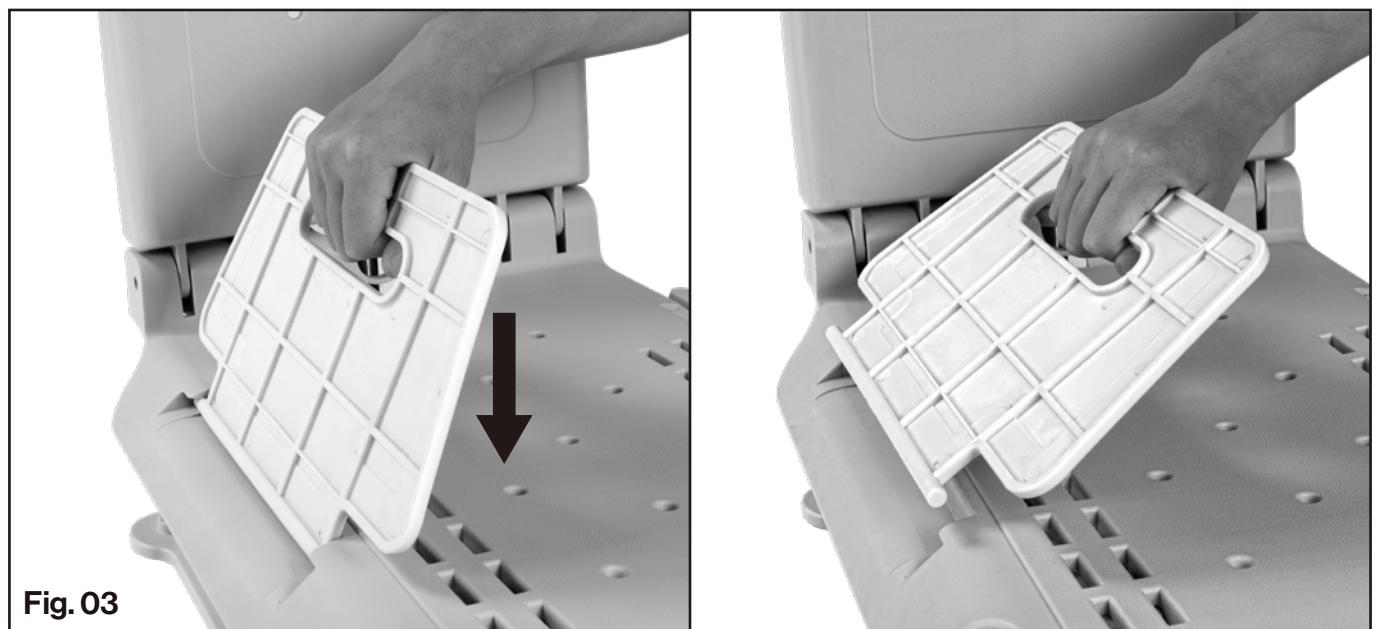
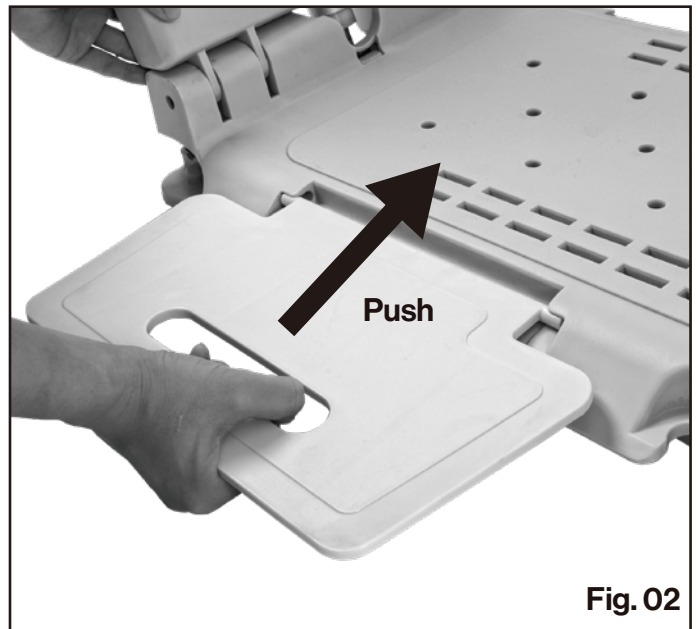

To charge the battery: (See Fig.04)



6. OPERATION

This lift can be used on the floor or in the bathtub. The usage method is actually the same. It helps you to lift by operating the wired remote. (See Fig.05)

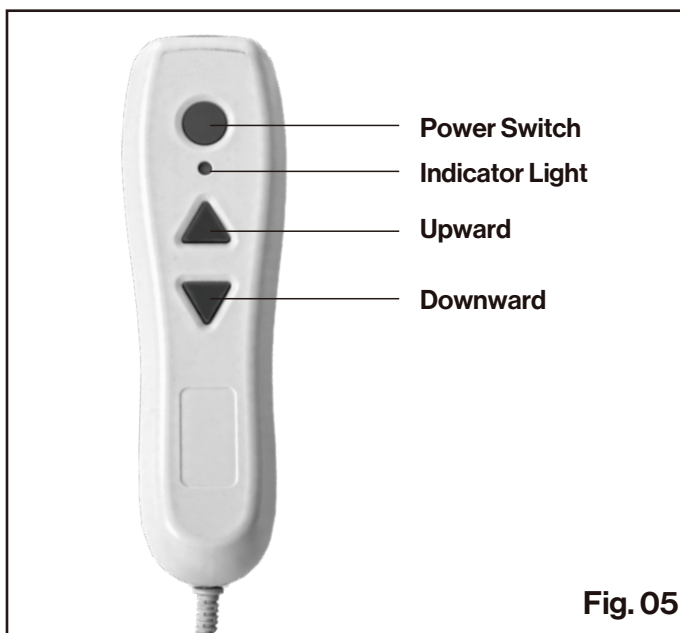

Pre-check: Evaluate whether the user is suitable for the device by considering aspects such as weight, body size, psychological capacity and joint mobility.

Power On: Press the power switch, the indicator light will turn solid green to indicate that the lift has been powered on.

Upward/Downward: Press and hold the up or down button, the green light flashes to indicate that the seat is moving up or down.

Shut Down: Press the power switch again, the indicator light goes out to indicate that the battery power has been turned off.

Automatic shut-down: If there is no actions on buttons over 10 minutes while the power is on, it will automatically shut down to save power.

Charging reminder: When the battery power is lower, the machine will beep and the indicator light will flash red to remind you to charge in time to avoid the device lose power.

NOTE: While the indicator light is flashing red, the device would only run for 2 or 3 cycles.

Charging: Connect the charger to the wired remote and plug it into the AC power supply. The charger indicator light will turn solid red to indicate that charging is in progress. The charging process may take 1.5 to 2 hours. When fully charged, the charger indicator light will turn solid green. Please note that the indicator light on wired remote will not show any indication when charging.

NOTICE: Please measure the size of the bathtub to confirm that the bathtub can accommodate this lift. And make sure the environment is safe before use. The main size information of this product is as follows.

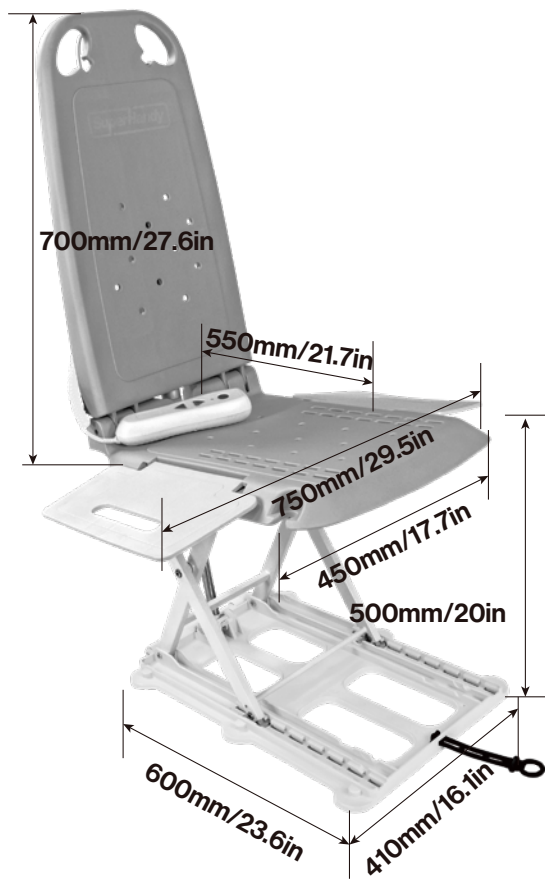

7. MAINTENANCE & STORAGE

The floor lift does not require regular maintenance. For optimal battery life, fully charge your device at least once every 90 days. When you don't need to use the floor lift, you can fold it up as shown below. (See Fig.06)

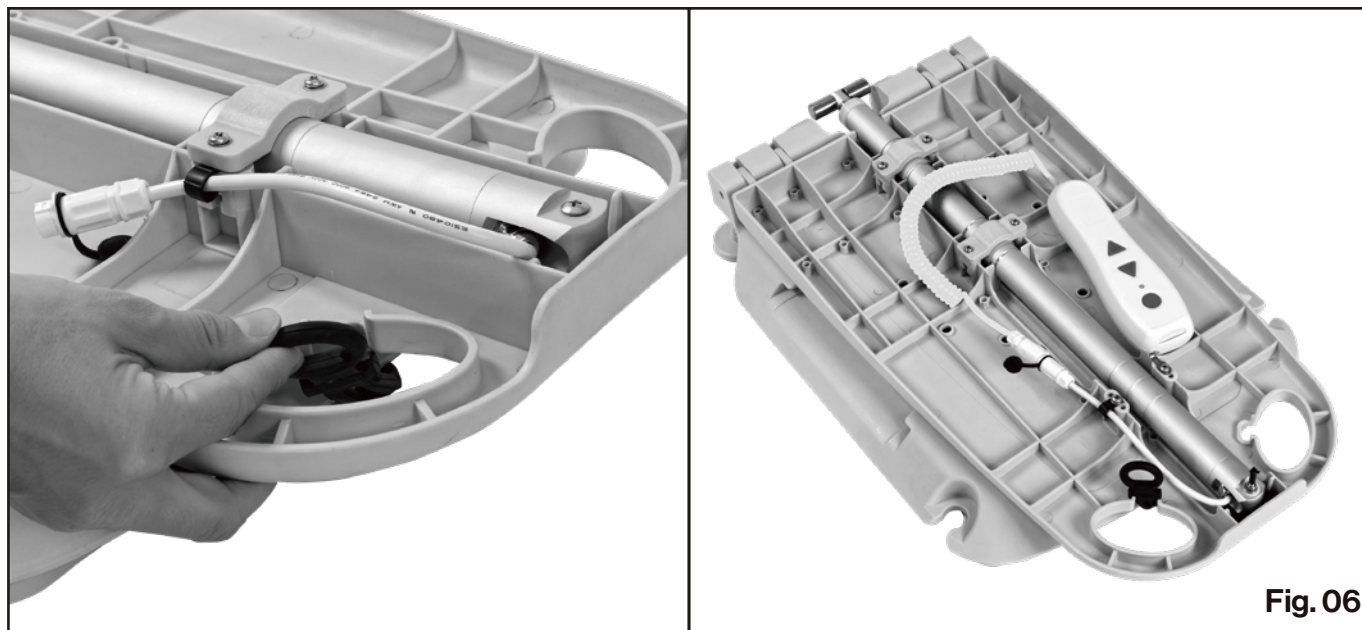

Fig. 06

8. WARRANTY

Warranty covers twelve (12) months for workmanship of the product, except for wearing parts. Warranty period starts from the product purchase date. Warranty covers material quality and workmanship only. Warranty does not cover product for issues caused by improper usage or any operation not in accordance with the specifications of this manual. Any modification or tampering with the product in any way voids the warranty.



Great Circle USA

Email: service@greatcircleus.com

www.greatcircleuk.com

www.greatcirclede.com