

VETTÄ TAP

THE TAP FILTRATION COMPANY

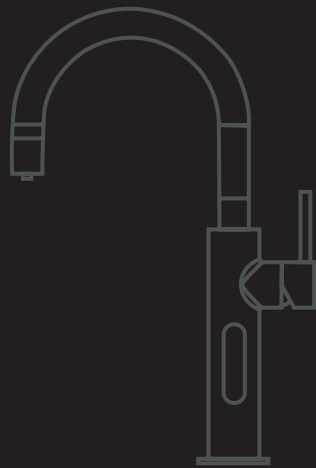

DIGITAL 5 IN 1

INSTALLATION AND USER MANUAL

VETTA TAP INSTALLATION & SAFETY GUIDE

Your Vettä Tap boiling water system is engineered for precision and longevity. To ensure peak performance and valid warranty coverage, please review the following guidelines thoroughly before installation.

1. Pre-Installation Requirements

1. Power Supply: A standard 220/240V grounded 13-amp switched electrical outlet is required. This must be located within the sink cupboard to power the heating tank.
2. Space & Ventilation: Ensure there is adequate clearance around the tank for ventilation and easy access to the water filter.
3. Compatibility: The Vettä Tap tank is an integrated system. It is only compatible with genuine Vettä Tap faucets. Using this tank with a third-party tap will void your warranty and may cause mechanical failure.

2. Critical Safety Instructions

1. Indoor Use Only: This system is not designed for outdoor installation or environments where temperatures may drop below freezing.
2. Professional Installation: While a detailed guide is provided, we strongly recommend hiring a licensed plumber for the installation to ensure all pressurised seals and electrical connections meet local building codes.
3. Component Check: Do not start the installation if any parts are missing or appear damaged. Contact Vettä Tap customer support immediately for replacements.

3. The "First Run" Process

1. Check Seals: Ensure all water connections are tightened and leak-free.
2. Fill the Tank: Turn on the water supply and open the boiling water handle. Do not plug the unit into the power outlet yet.
3. Purge Air: Keep the tap open until water flows steadily. This indicates the tank is full. We recommend flushing several litres through the system to clear trapped air and installation debris.
4. Power On: Only once the tank is confirmed full and flushed should you plug the unit into the 13-amp outlet and switch it on.

4. Maintenance & Compliance

1. Open-Vented System: To comply with UK regulations and prevent dangerous pressure build up, this is an open-vented system. You may notice a slight "drip" from the spout during the heating cycle; this is normal expansion and a key safety feature.
2. Limescale & Filtration: To maintain water purity and protect the internal heating elements from limescale, the water filter must be replaced every 6 months.

Note: Failure to replace the filter at the recommended intervals may lead to system blockages and will affect your warranty status.

WARNING

- Do not install the unit in environments exceeding 35°C or in areas prone to freezing
- Never handle electrical connections with wet hands.
- Do not proceed with installation if the appliance appears damaged.
- Use only the provided power cord and contact customer service for a replacement if it fails.
- Do not remove the tank casing; the unit is not user-serviceable and must be returned for repairs.
- Refrain from modifying the tank or removing the plug to avoid injury and keep your warranty valid.
- Connect the appliance only to a standard UK 3-pin socket.
- Unplug, drain, and refill the tank if the unit will not be used for an extended period.
- Clean the tap and tank using only a soft, damp cloth.
- Avoid abrasive or harsh chemicals that could damage the finish.
- Ensure water pressure is between 1.5 and 5 bar; install a pressure-reducing valve if it exceeds 5 bar.
- Replace the water filter every 6 months to maintain performance.

INSTALLATION PARTS

- | | |
|-------------------------------------|-----------------------------------|
| 1. Braided hose for cold water | 9. 3/8 to 1/4 pipe reducer |
| 2. Braided hose for hot water | 10. 3/8 push fit pipe |
| 3. Braided hose for chiller inlet | 11. 1/4 push fit pipe |
| 4. Braided hose for boiling water | 12. 3 way cold mains Tee |
| 5. Braided hose connector to filter | 13. 2 way pipe divider |
| 6. Boiler adapter for 1/4 pipe | 14. Pressure reduce valve |
| 7. Control box | S1. Signal cable from tap |
| 8. 1/4 pipe Tee connector | S2. Signal cable from control box |

INSTALLATION DIAGRAM

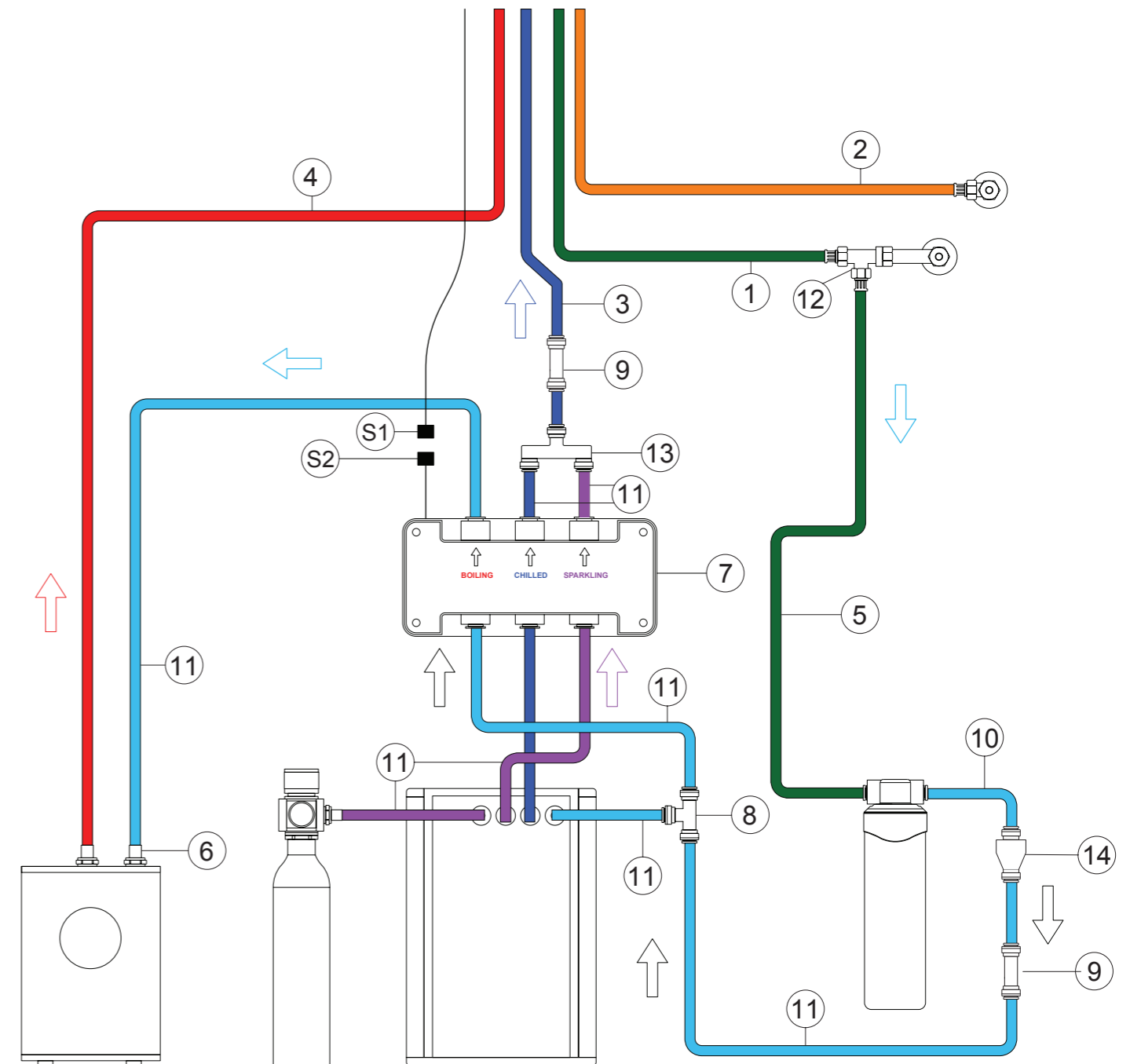

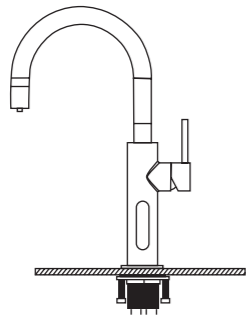
1

Before installing, remove both the rubber washer, metal washer and locking nut. Then insert all hoses, including signal cable through the hole.

Once in place, secure the tap by installing the rubber washer, followed by metal wash and then securing in place with the fixing nut.

Once in place, use a phillips screwdriver to tighten the two fixing screws.

3

Connect the 3/8" Plastic Tubing (10) between the filter and the 3/8 to 1/4 reducer (9). Then from the reducer (9) to one side of the plastic 3-way connector (8) by removing the blue clip first and then re-attach the clip to secure into place.

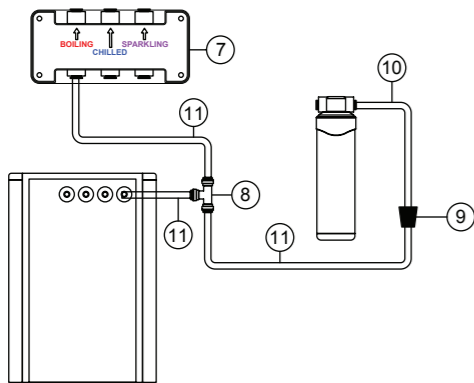

From the tee (8), take 2x 1/4 pipe (11) out of the tee, by removing the blue clip first and then secure by using the blue clip once attached.

Connect one of the tube (11) into the water inlet of the chiller.

Connect the remaining tube (11) into the boiling inlet of the control box (7).

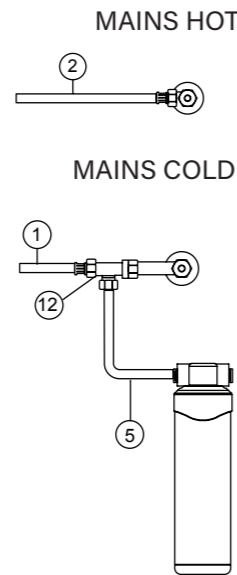
2

Install the Pressure Reducing Valve (15) onto the cold inlet & connect the metal T piece (9) to the outgoing of the PRV. Then Connect the cold water inlet hose (1) to one side of the T piece and tighten it all with an adjustable spanner.

Connect the hot water inlet hose (2) to your mains hot water supply and tighten it with an adjustable spanner

Attach hose (5) to the metal T-piece on the cold mains and secure it using an adjustable spanner. Then, connect the other end of hose (5) to the filter's inlet.

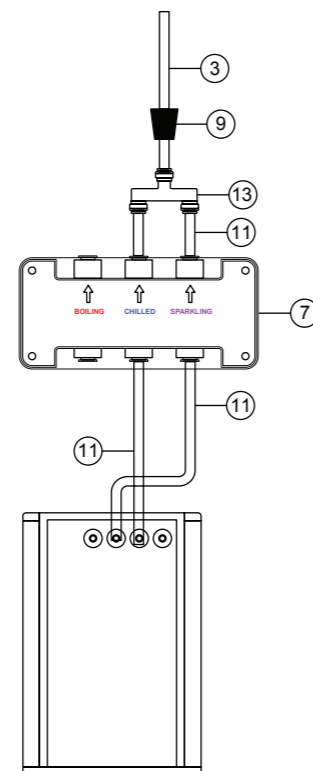
4

Take another 2x 1/4 tubing (11). Connect the first one from the cold water outlet on the chiller and connect it to the chilled water inlet on the control box (7).

Take the second tube and connect it from the sparkling water outlet on the chiller and then connect it into the sparkling water inlet on the control box (7).

Next connect hose (3) from the tap, and connect it into the 2 way divider (13), by attaching the adapter (9).

Connect the other 2 ends of the 2 way divider (13) into the chilled water outlet & the sparkling water outlet on the control box (7).

5**DO NOT SWITCH ON POWER**

Connect 1/4 tube (11) from the boiling outlet at the control box (7), to the boiler inlet (blue), using the adapter provided (6).

Next connect the hose (4) from the tap and connect it to the outgoing of the boiler (red).

Connect the CO2 using 1/4" Plastic Tubing (11) and connect to CO2 inlet on the Chiller. Do not connect the CO2 gas cylinder.

Connect together the signal cables (S1 & S2) together and insert the power adaptor to the control box.

Insert the power cables for both boiler & chiller.

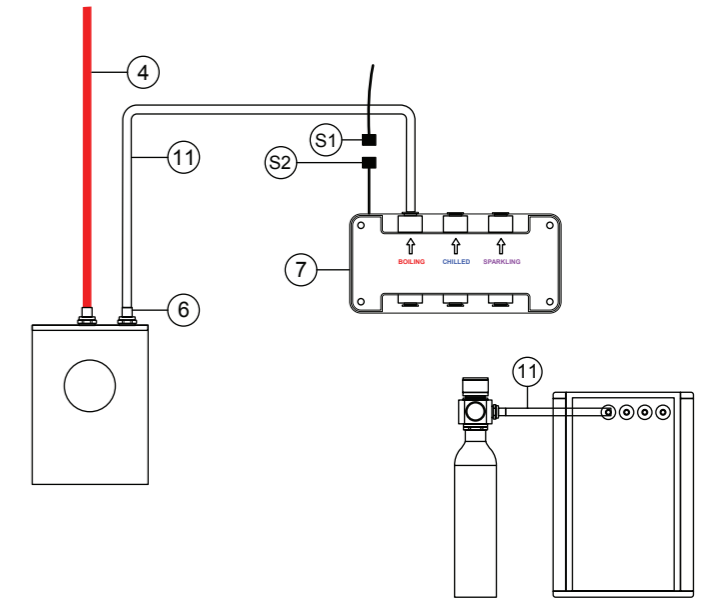
**6****DO NOT SWITCH ON POWER**

Turn on your mains hot & cold water, checking all connections for any leaks.

Turn on the power for the control box and lights should appear on the digital tap.

To unlock the digital pad, touch the lock until the other functions illuminate (3 seconds).

Touch and hold the boiling water function (red), until water dispenses from the tap (the boiler will need to fill and may take a minute). Repeat this process for the chilled & sparkling water functions.

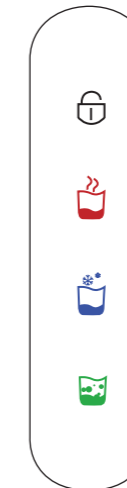
**7****SWITCH ON POWER**

Once the system has fully filled, you can proceed with powering both the boiler & chiller.

Then proceed with installing the CO2 gas cylinder. This should be set to 3 bars of pressure. It is recommended to turn shut down the system whenever replacing your CO2 gas cylinders.

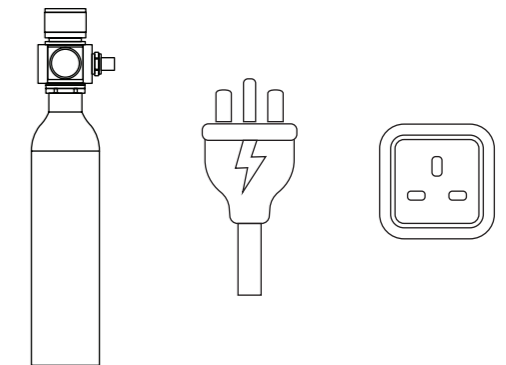

CUSTOMER CARE

Please contact us with any technical help or after sales support.

 01245 820 840

 support@vettatap.com

 www.vettatap.com

