

# VETTÄ TAP

THE TAP FILTRATION COMPANY



## **DIGITAL 4 IN 1**

INSTALLATION AND USER MANUAL

## **VETTA TAP INSTALLATION & SAFETY GUIDE**

Your Vettä Tap boiling water system is engineered for precision and longevity. To ensure peak performance and valid warranty coverage, please review the following guidelines thoroughly before installation.

### **1. Pre-Installation Requirements**

1. Power Supply: A standard 220/240V grounded 13-amp switched electrical outlet is required. This must be located within the sink cupboard to power the heating tank.
2. Space & Ventilation: Ensure there is adequate clearance around the tank for ventilation and easy access to the water filter.
3. Compatibility: The Vettä Tap tank is an integrated system. It is only compatible with genuine Vettä Tap faucets. Using this tank with a third-party tap will void your warranty and may cause mechanical failure.

### **2. Critical Safety Instructions**

1. Indoor Use Only: This system is not designed for outdoor installation or environments where temperatures may drop below freezing.
2. Professional Installation: While a detailed guide is provided, we strongly recommend hiring a licensed plumber for the installation to ensure all pressurised seals and electrical connections meet local building codes.
3. Component Check: Do not start the installation if any parts are missing or appear damaged. Contact Vettä Tap customer support immediately for replacements.

### **3. The "First Run" Process**

1. Check Seals: Ensure all water connections are tightened and leak-free.
2. Fill the Tank: Turn on the water supply and open the boiling water handle. Do not plug the unit into the power outlet yet.
3. Purge Air: Keep the tap open until water flows steadily. This indicates the tank is full. We recommend flushing several litres through the system to clear trapped air and installation debris.
4. Power On: Only once the tank is confirmed full and flushed should you plug the unit into the 13-amp outlet and switch it on.

### **4. Maintenance & Compliance**

1. Open-Vented System: To comply with UK regulations and prevent dangerous pressure build up, this is an open-vented system. You may notice a slight "drip" from the spout during the heating cycle; this is normal expansion and a key safety feature.
2. Limescale & Filtration: To maintain water purity and protect the internal heating elements from limescale, the water filter must be replaced every 6 months.

Note: Failure to replace the filter at the recommended intervals may lead to system blockages and will affect your warranty status.

## WARNING

- Do not install the unit in environments exceeding 35°C or in areas prone to freezing
- Never handle electrical connections with wet hands.
- Do not proceed with installation if the appliance appears damaged.
- Use only the provided power cord and contact customer service for a replacement if it fails.
- Do not remove the tank casing; the unit is not user-serviceable and must be returned for repairs.
- Refrain from modifying the tank or removing the plug to avoid injury and keep your warranty valid.
- Connect the appliance only to a standard UK 3-pin socket.
- Unplug, drain, and refill the tank if the unit will not be used for an extended period.
- Clean the tap and tank using only a soft, damp cloth.
- Avoid abrasive or harsh chemicals that could damage the finish.
- Ensure water pressure is between 1.5 and 5 bar; install a pressure-reducing valve if it exceeds 5 bar.
- Replace the water filter every 6 months to maintain performance.

## INSTALLATION PARTS

- |    |                                  |     |                               |
|----|----------------------------------|-----|-------------------------------|
| 1. | Braided hose for cold water      | 9.  | 3/8 to 1/4 pipe reducer       |
| 2. | Braided hose for hot water       | 10. | 3/8 push fit pipe             |
| 3. | Braided hose for tap inlet       | 11. | 1/4 push fit pipe             |
| 4. | Braided hose for boiling water   | 12. | 3 way cold mains "tee"        |
| 5. | Braided hose connector to filter | 13. | Pressure reducer valve        |
| 6. | Boiler adapter for 1/4 pipe      | S1. | Signal cable from tap         |
| 7. | Control box                      | S2. | Signal cable from control box |
| 8. | 1/4 pipe "tee" connector         |     |                               |

## STANDARD INSTALLATION DIAGRAM

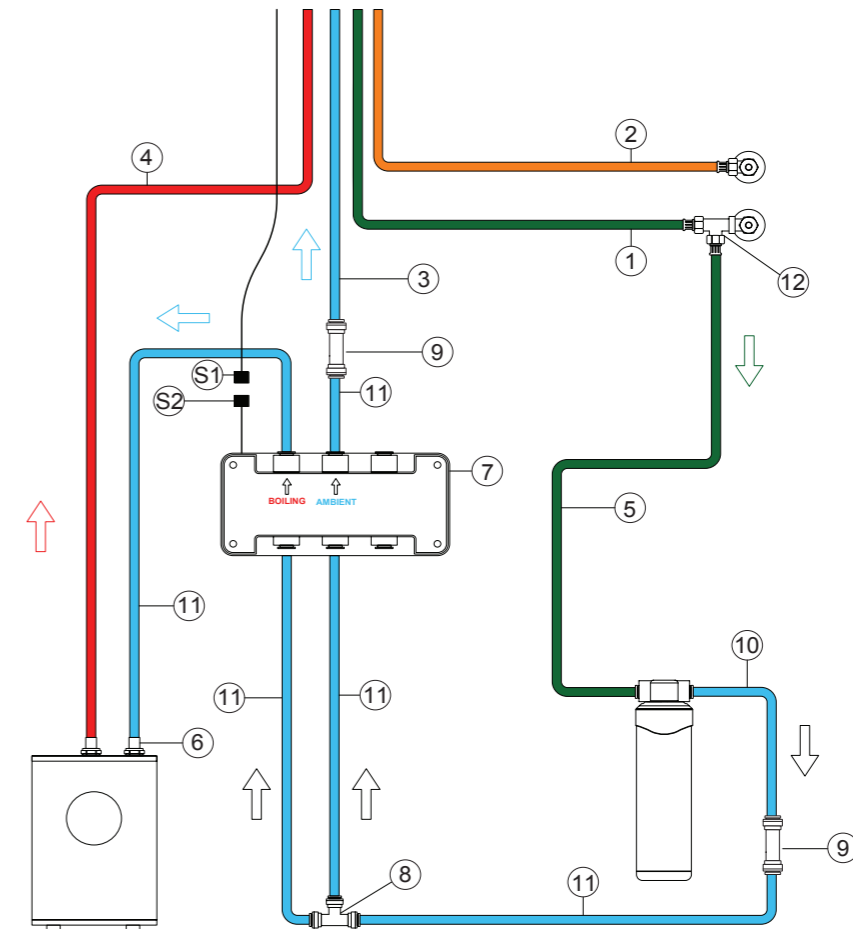

## CHILLER INSTALLATION DIAGRAM

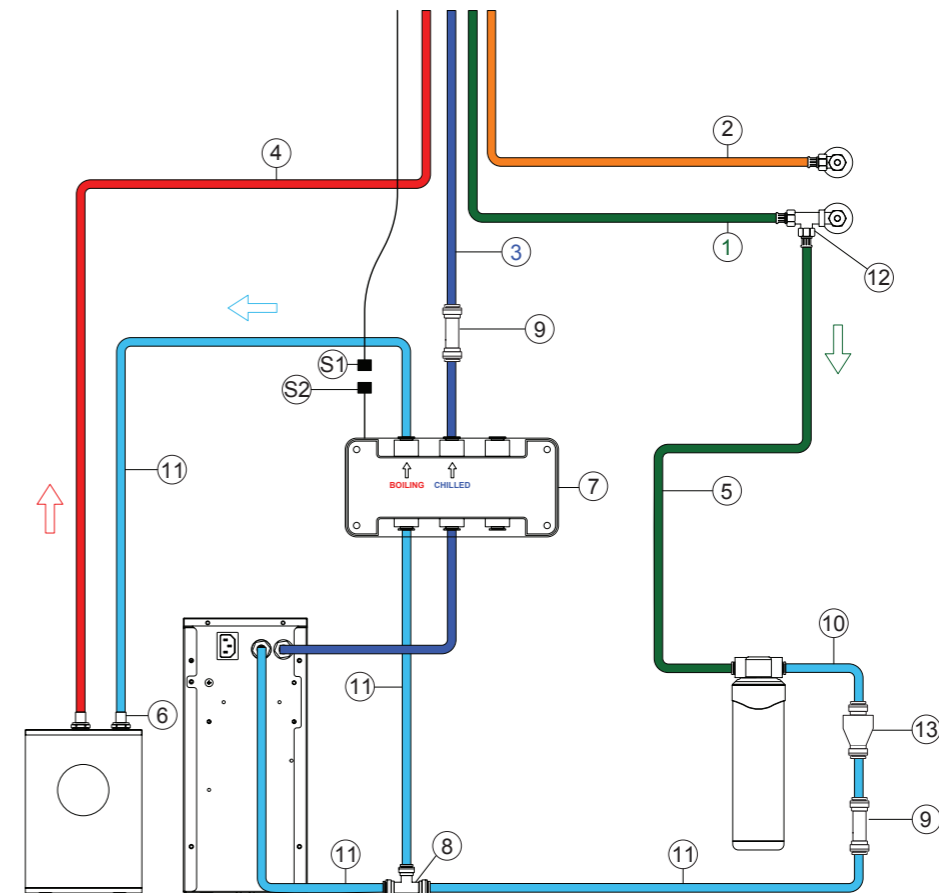

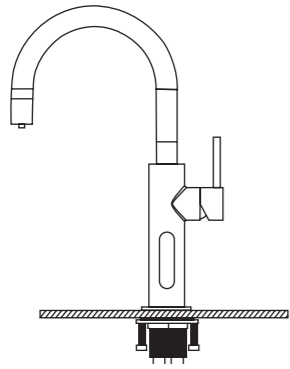
**1**

Before installing, remove both the rubber washer, metal washer and locking nut. Then insert all hoses, including signal cable through the hole.

Once in place, secure the tap by installing the rubber washer, followed by metal wash and then securing in place with the fixing nut.

Once in place, use a phillips screwdriver to tighten the two fixing screws.

**2**

MAINS HOT

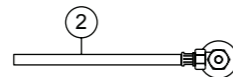

Connect the metal T piece (12) to the cold outlet. Then Connect the cold water inlet hose (1) to one side of the T piece and tighten it all with an adjustable spanner.

MAINS COLD

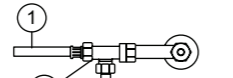

Connect the hot water inlet hose (2) to your mains hot water supply and tighten it with an adjustable spanner

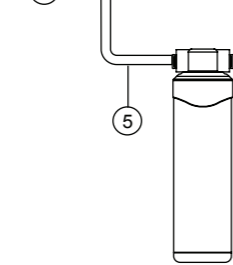

Attach hose (5) to the metal T-piece on the cold mains and secure it using an adjustable spanner. Then, connect the other end of hose to the filter's inlet.

**3**

**IF YOU HAVE A CHILLER, PLEASE REFER TO STEP 4**

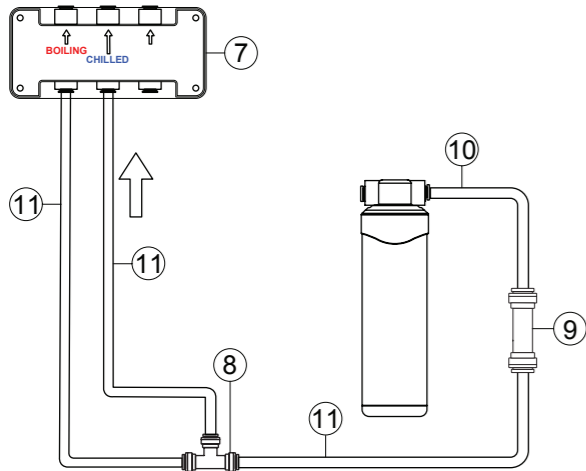

Connect the 3/8" plastic pipe (10) between the filter and the reducer (9) and then into to one side of the plastic 3-way connector (8) by removing the blue clip first and then re-attach the clip to secure into

From the tee (8), take two 1/4 pipe. insert one into the boiler inlet and one into the chilled inlet of the control box (7).

**7**

**CHILLER INSTALLATION**

Connect the 3/8" plastic pipe (10) between the filter and the PRV (14) and then take another 3/8 pipe from the PRV into the reducer (9).

insert 1/4 pipe into the reducer and connect the other end to the 3-way tee connector (8).

From the tee (8), take two 1/4 pipe. insert one into the boiler inlet and one into the "water inlet" of the chiller. take another 1/4 pipe from the "water outlet" of the chiller and into the chilled inlet of the control box (7)

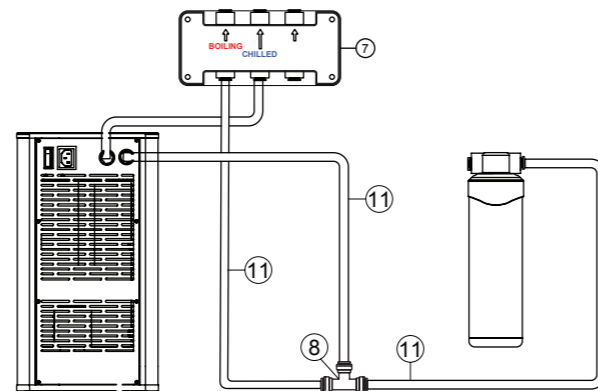
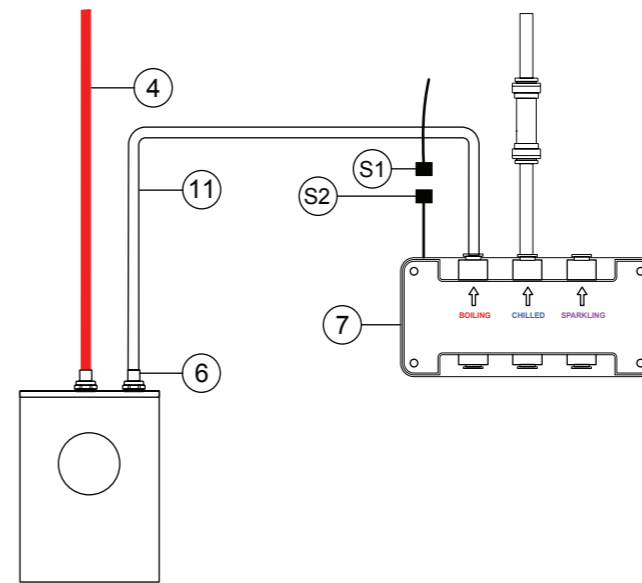
**5**

**DO NOT SWITCH ON POWER**

Connect 1/4 pipe (11) from the boiling outlet at the control box (7), to the boiler inlet (blue), using the adapter provided (6).

Next connect the hose (4) from the tap and connect it to the outgoing of the boiler (red)

Connect 1/4 pipe (11) from the chilled outlet of the control box (7), into the reducer (9), then to tape hose (3).

Connect together the signal cables (S1) & (S2) together and insert the power adaptor to the control box.

Insert the power cables for both boiler & chiller

**6**

**DO NOT SWITCH ON POWER**

Turn on your mains hot & cold water, checking all connections for any leaks.

Turn on the power for the control box and lights should appear on the digital tap.

To unlock the digital pad, touch the lock until the other functions illuminate (3 seconds).

Touch and hold the boiling water function (red), until water dispenses from the tap (the boiler will need to fill and may take a minute). Repeat this process for the chilled & sparkling water functions.

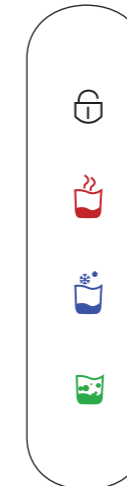
**7**

**SWITCH ON POWER**

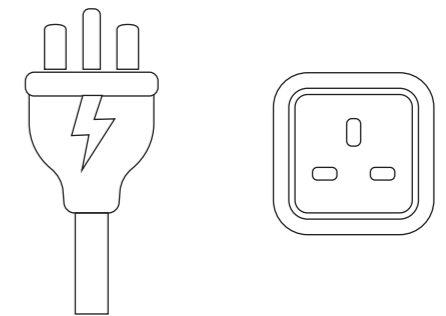

Once the system has fully filled, you can proceed with powering both the boiler & chiller.

## CUSTOMER CARE

Please contact us with any technical help or after sales support.

 01245 820 840

 support@vettatap.com

 www.vettatap.com

