

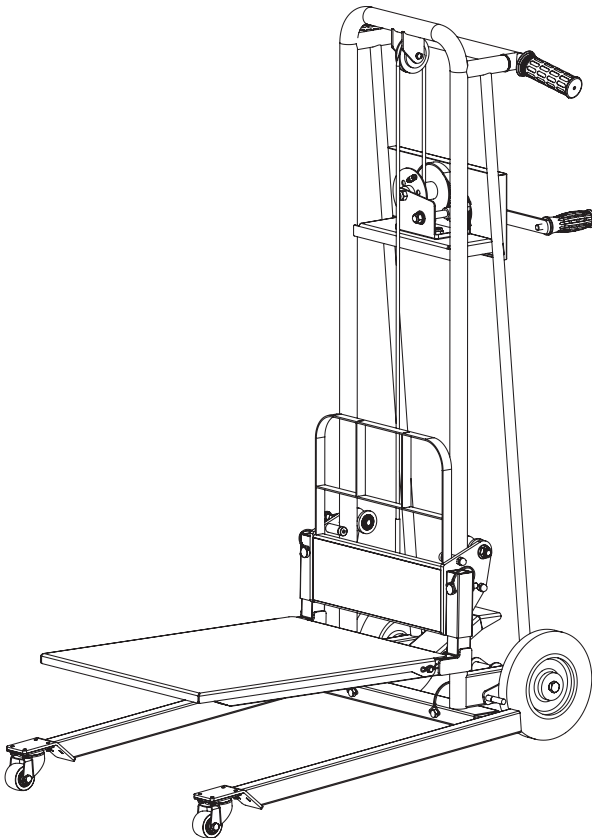

330Lbs Material Lift Operator's Manual



WARNING:

Carefully review and understand all INSTRUCTIONS prior to operating this device. Failure to follow the safety rules and other basic safety precautions may result in serious personal injury. Keep these instructions in a safe place and accessible so that they can be reviewed as required. Keep these instructions to assist in future servicing needs.



INDEX

1. WARNING -----	1
2. MAIN USE -----	1
3. TECHNICAL SPECIFICATIONS -----	1
4. ASSEMBLY -----	2~6
5. COMMISSIONING&PREPARATION -----	6
6. MAIN COMPONENTS-----	7
7. OPERATION -----	8~10
8. MAINTENANCE -----	10~13
9. TRANSPORTATION&STORAGE -----	13
10. WARRANTY -----	13
11. TROUBLE SHOOTING -----	14
12. EXPLODED AND PARTS LIST -----	15

1. WARNING

- Before using or performing maintenance on your Material Lift, please read the manual thoroughly to familiarize yourself with the proper usage of and maintenance of your product.
- This Material Lift should only be used in a professional and safe manner, Maintenance and Testing Personnel should only use this equipment when necessary.
- The material lift must be inspected before use, if a material lift is damaged, has malfunctioning or missing parts, do not use, contact the manufacturer for replacement parts.
- Unauthorized modifications to the product in any way are not permitted and can be dangerous. Unauthorized modifications will automatically void all product warranty and the manufacturer bears no liability to damages or injuries caused by such unauthorized modifications.
- Do not place your legs, feet or other body parts under the lift during using.
- This lift is not designed for the use of transporting or lifting people, pets or livestock of any sort.
- To avoid the risk of lift overturning when loading, ensure that the center of gravity of the heavy objects is in the right place on the forks or flatbed (refer to 7.1).
- All heavy objects should be centered properly before lifting or moving the unit.
- Do not turn the winch counterclockwise to lift weight.
- Do not put polyethylene rope close to a fire source or sharp objects, such as blade.
- Do not overload the lift.
- The operator must not leave the lift unattended while in use during the lifting process of the heavy objects. When walking away from the Lift, operator must lower the height of the heavy objects.
- Do not remove or obscure the labels on the lift, make sure all labels are clear and easy to read, otherwise do not use it.
- Do not operate this material lift if you are under 16 years old.

2. MAIN USE

Material lift with compact design and ease of operation. Intended for small and medium-sized warehouses, processing workshops, home areas handling or loading and unloading heavy objects, can achieve short distance or small space to move heavy objects and other operations.

3. TECHNICAL SPECIFICATIONS

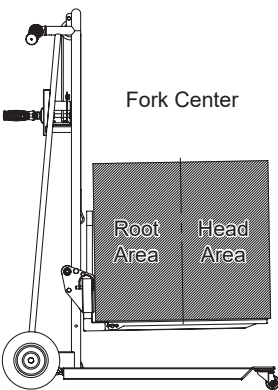

SKU#	GBOS010
Lifting Height	1000mm (39.37")
Max. Lifting Weight	150Kgs (330Lbs)
Towing Form	Fork; Flatbed (option)
Lift Height	80~1000mm (3.14"~39.37")
Fork Size	600x450mm (23.62"x17.71")
Plate Size	595x452mm (23.42"x17.79")
Item Size	970x600x1300mm (38.2"x23.6"x51.2")
Net Weight	36Kgs (79Lbs)

- The maximum load capacity of the heavy objects in area from center to root area is 150Kgs (330Lbs).
- The maximum load capacity of the heavy objects in head area is 70Kgs (156Lbs).

4. ASSEMBLY

Part No.	Description	Q'ty	Part No.	Description	Q'ty
1	Primary frame	1	6	Flat plate	1
2	Wheel 8"	2	7	Handlebar	1
3	Bushing	2	8	Winch handle	1
4	Wheel carrier	2	9	Wheel Axle	1
5	Fork	2			

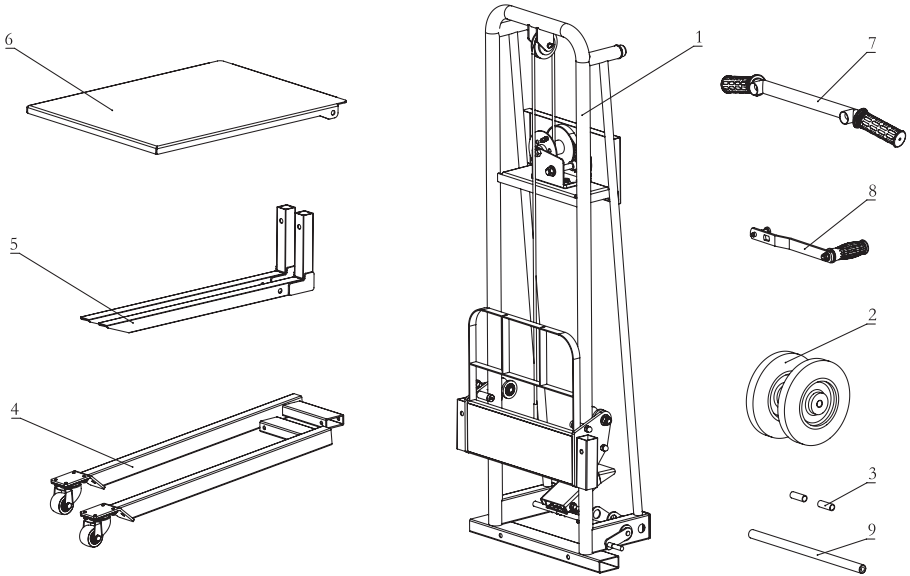

R-pin
2 pcs

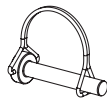

D-pin
2 pcs

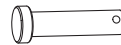

Pin
2 pcs



Hex socket round
head bolts M8x45
2pcs



Hexagon flange bolt
M8x30
2pcs



D-pin 8x80
2pcs



Hexagon Bolt
M12x65
2pcs

Assembly Steps

Step 1: Wheel Axle Installation

Insert the wheel axle (A) into the holes of the base (B) and pedals (C, D). (See Fig.1)

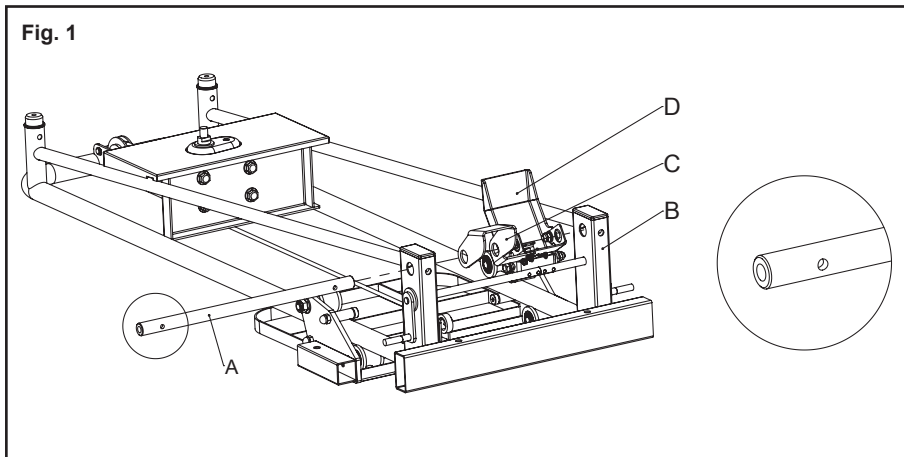

Step 2: Wheel Axle Fixation

Insert the flange bolt M8x30 (B) into the hole of the wheel axle (A), and tighten the bolt. (See Fig.2)

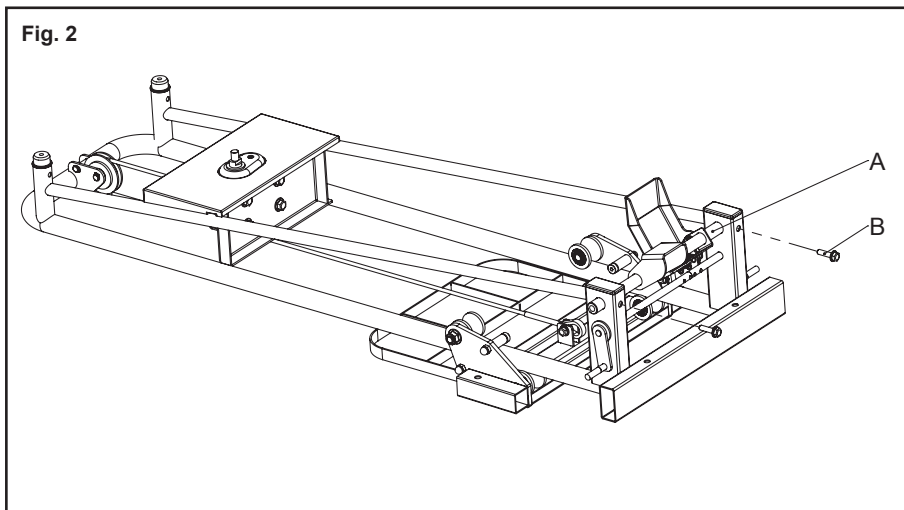

Step 3: Wheel Installation

Use hexagonal bolt (A) M12x65 to tighten the bushing (B), wheel (C), and wheel axle (D).
(See Fig.3)

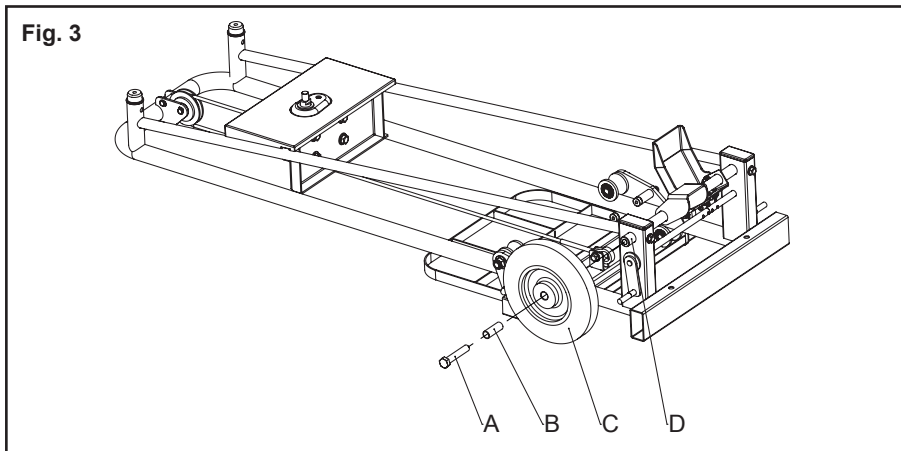

Step 4. Wheel Carrier Assembly Installation

Insert the wheel carrier assembly (A) into the base (C), aligning the holes, then use the D-shaped pin (B) to insert into the base holes and secure it in place. (See Fig.4)

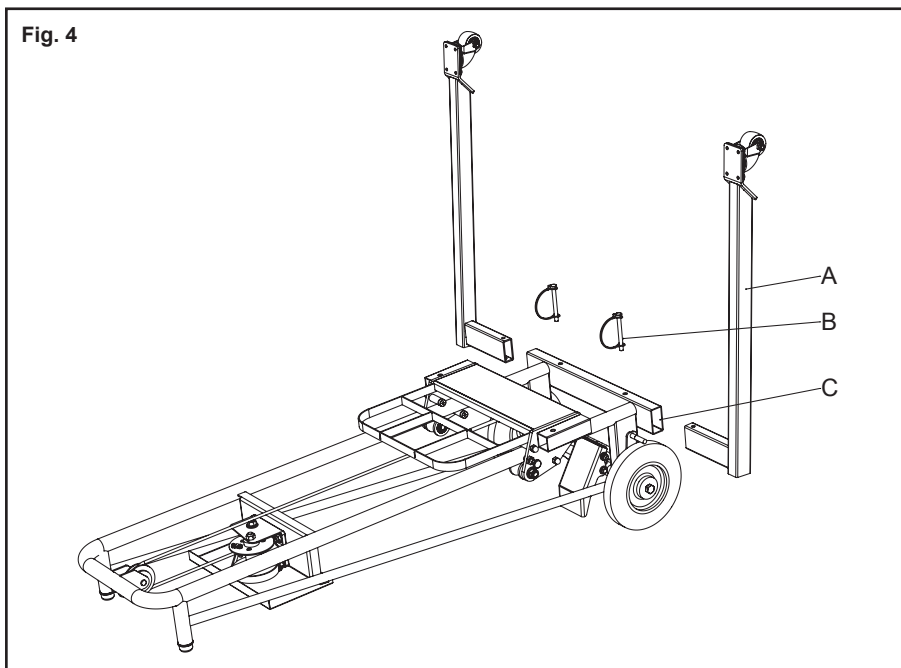

Step 5. Fork

Insert the fork (C) into the fork interface (A), making sure the fork (C) hole is aligned with the fork interface (A) hole. Insert the D-pins (B) into the fork interface (A) holes and secure them. Recommended tools: rubber hammer- knock the fork into the hole. (See Fig.5)

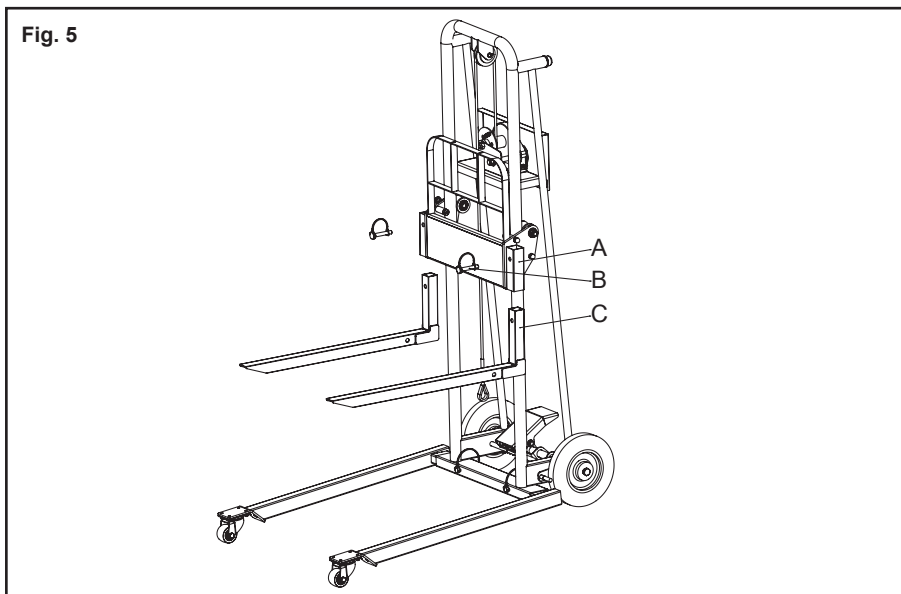

Step 6: Flat plate

First, the flat plate (B) is placed flat on the fork (C). Second, the holes on both sides of the plate and the fork are aligned. Third, the Pin (A) is inserted and fixed with an R-pin (D). (See Fig.6)

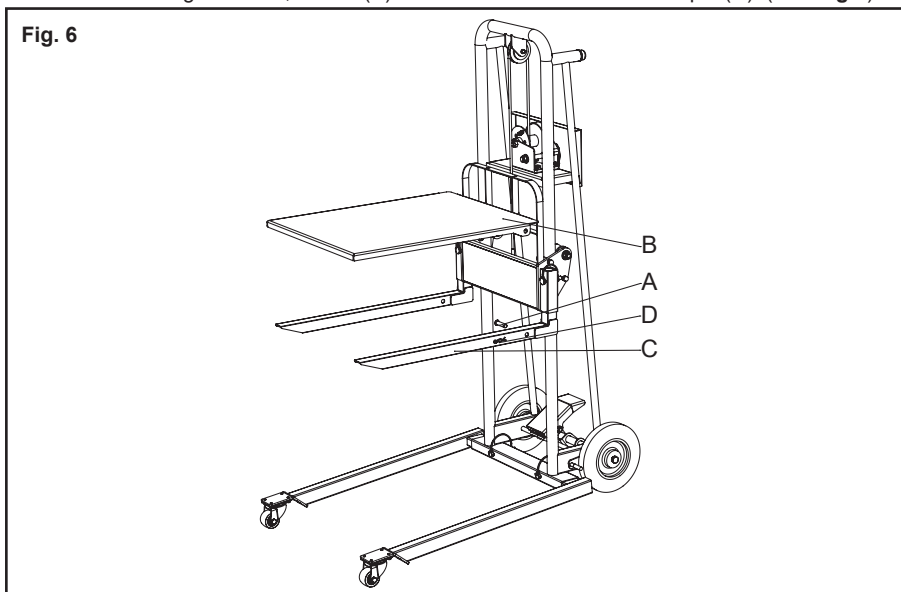

Step 7: Handlebar

Insert the handlebar (B) into the locating block (A) and tighten with M8x45 bolt (C). (See Fig.7)

Note: Ensure that the handle is facing downward.

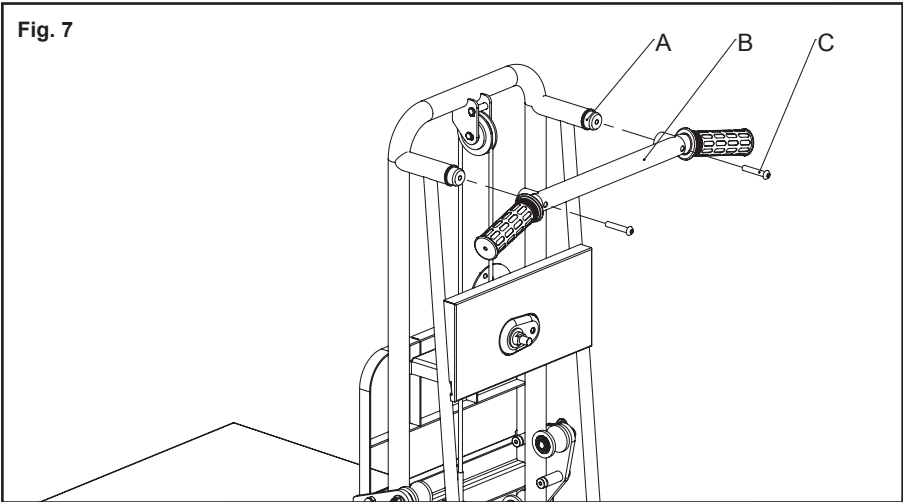

Step 8: Winch handle

First, insert the handle (A) and washer (C) onto the winch in the sequence shown in the diagram, and tighten the handle with M12 nut (B). (See Fig.8)

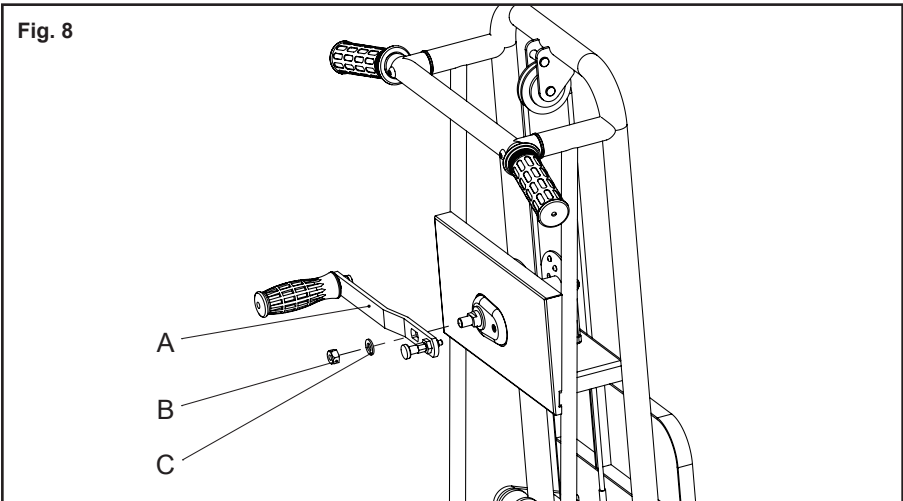

5. COMMISSIONING&PREPARATION

1. Check that all bolts are tightened securely before operation.
2. Perform a No-load test run prior to initial usage, to confirm that the universal wheel rotation flexible, forward and backward movement freely.
3. Verify that the weight being handled or loaded does not exceed 330lb (150Kgs).
4. This equipment with brake device, please park on flat ground. Never leave or park your material Lift with a heavy load on any slope.

6. MAIN COMPONENTS

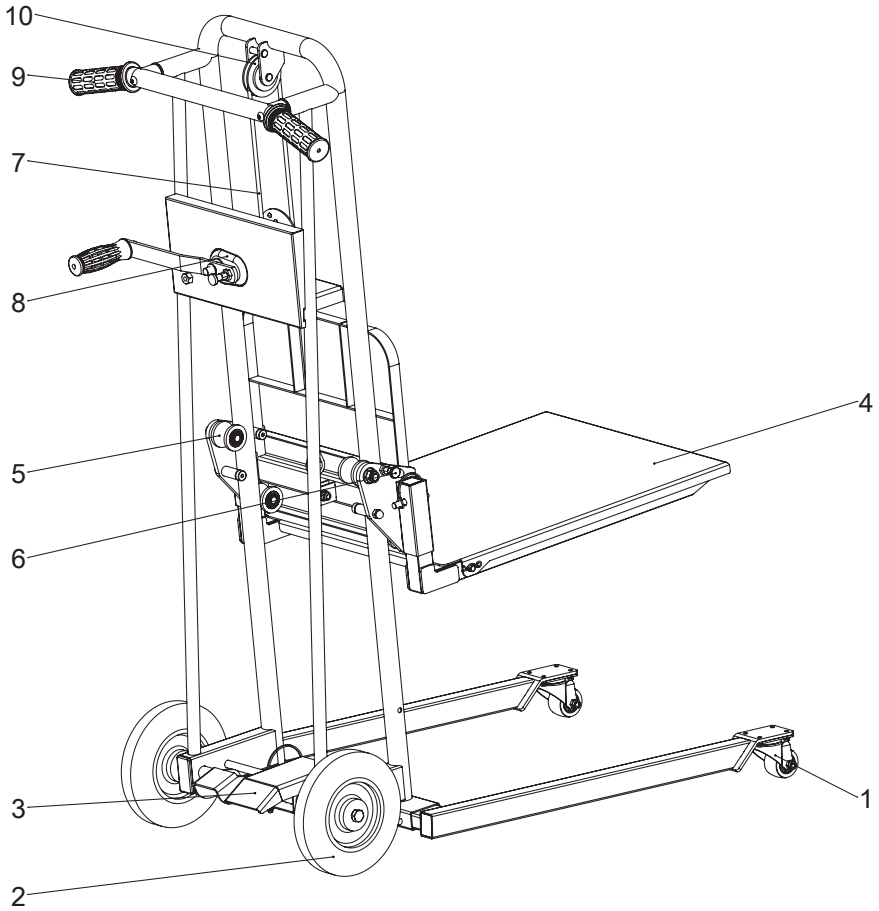

Part No.	Description	Part No.	Description
1	Universal wheel (2")	7	Polyethylene rope
2	Directional wheel (8")	8	Winch: handle clockwise rotation to lift the fork height, counterclockwise rotation to lower the fork height.
3	Brake pedal: control equipment parking	9	Handle
4	Fork; Plate	10	Polyethylene rope roller
5	Roller		
6	Positioning pin		

7. OPERATION

7.1 Placement of heavy objects

- a. Place the heavy objects on the fork flatbed with the center of the heavy objects aligned with the center of the fork (shown as below).
- b. If the heavy objects may slide, always center the heavy objects and secure it to the forks.

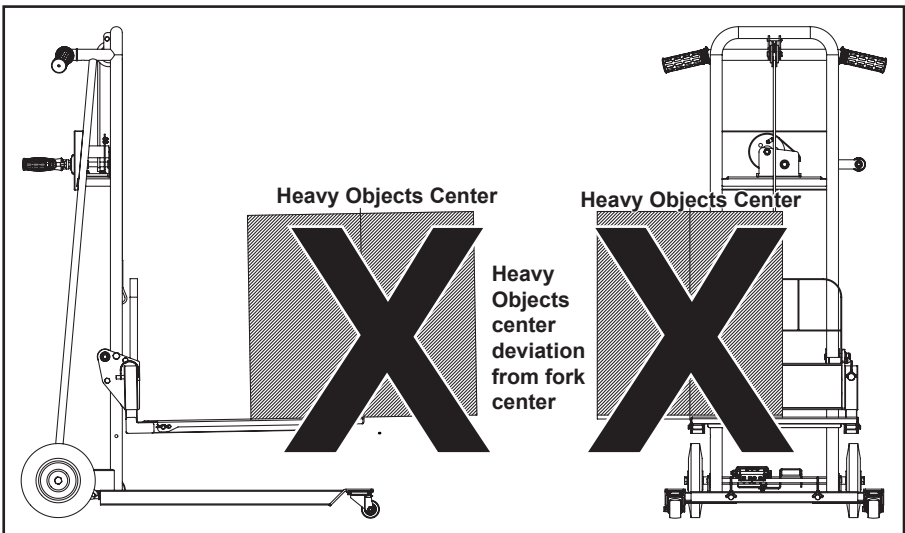
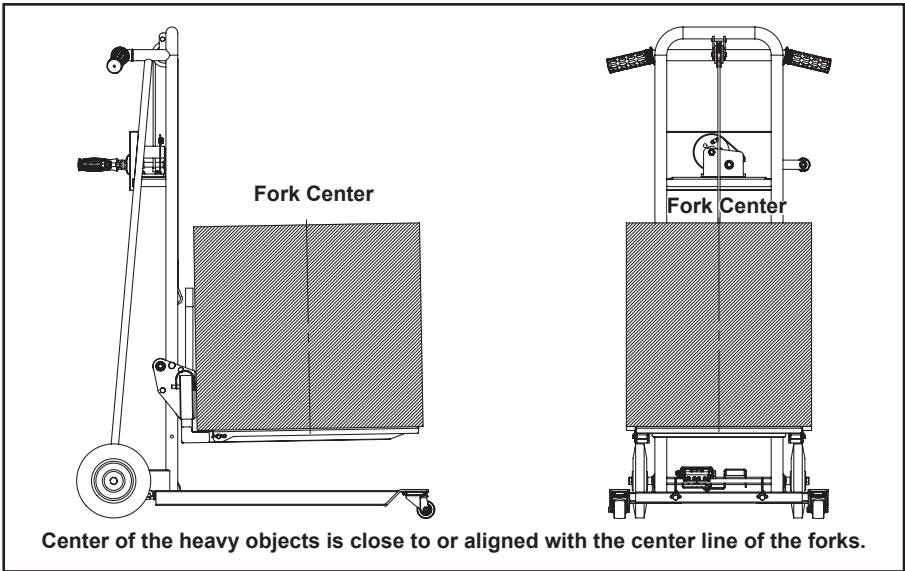

7.2. Operation of the brake mechanism

- When moving the lift, make sure the brake device of the lift is in the off position. the operation method is: press the pedal with your foot to release the break, as shown below (**See Fig. A**)
- When the lift truck is stopped or parked for a long time, in order to avoid the risk caused by the sliding of the lift truck, the brake device needs to be in the engaged position, and the operation method is: press the brake pedal with your foot. (**See Fig. B**)

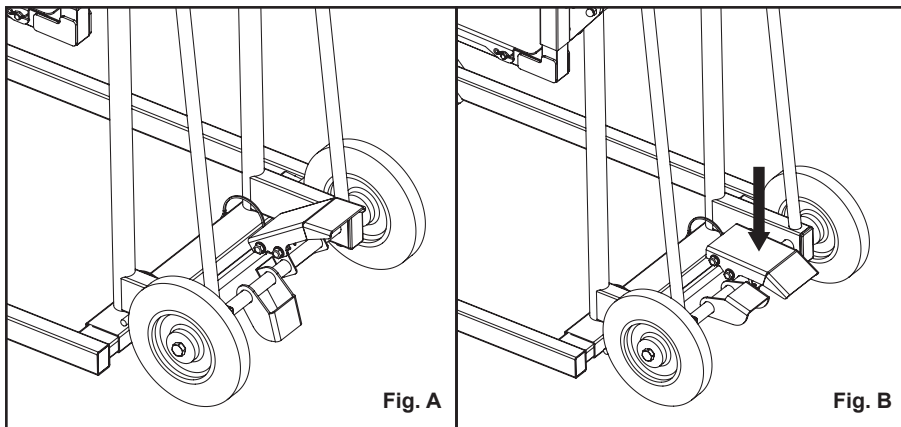

7.3. Heavy Objects handling

7.3.1 Basic operations

- Place the heavy objects on the lift, see 7.1 for details of placement.
- Before moving the lift, make sure the brakes of the lift are released. When the lift is stopped or parked for a long time, the brakes should be in the braking state (see 7.2 for details of operation).

7.3.2 Tilt operation

If the lift truck carries heavy objects within 60Kgs, in order to increase the driving speed and improve the working efficiency, the lift truck (including the heavy objects) can be tilted at a suitable angle and operated in the following way.

- Fork height from the base not exceeding 200 mm.
- Holding the armrest position with both hands.
- Hold the wheel axle of the base with the foot and use both hands to tilt the lift back at the right angle.
- Maintain the proper angle of backward tilt and drag the lift to travel.
- Step on the wheel axle of the base with your foot and slowly put down the lift until all four wheels touch the ground.

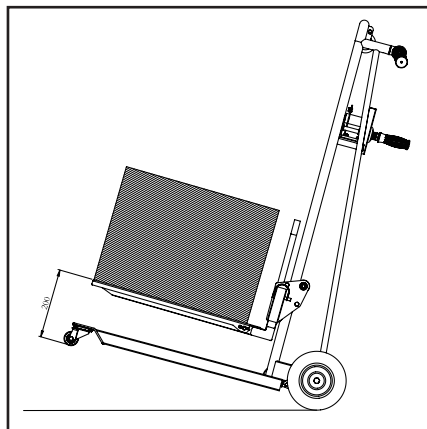

7.4. Positioning pin operation

To prevent the forks from sliding when handling the lift, please screw the star bolt into the hole of the tube to fix the forks.

Please loosen the star bolt when you need to lift.

7.5. Folding handle operation

Folding operations.

- a. Pull the handle outward for a short distance.
- b. Then turn the handle to the inside, you can complete the folding operation.

7.6 Indexing pin operation

If the handle is in the locked state, pull out the index pin in the direction of the arrow and rotate it 90 degrees to perform the lifting operation; otherwise, insert the index pin into the positioning hole to lock the handle, which can prevent fork or flat slides down

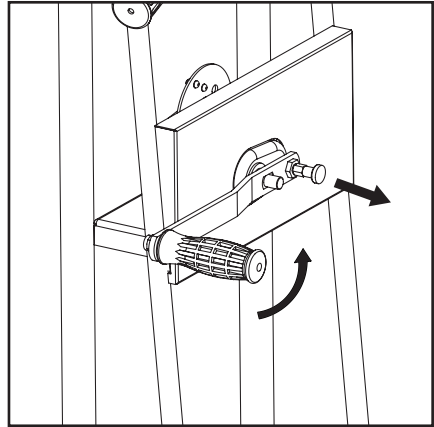

8. MAINTENANCE

8.1 Directional wheel replacement

- a. Loosen the bolts and remove the bushing and wheels.
- b. Replace with new wheels and tighten them along with the bushing using bolts.

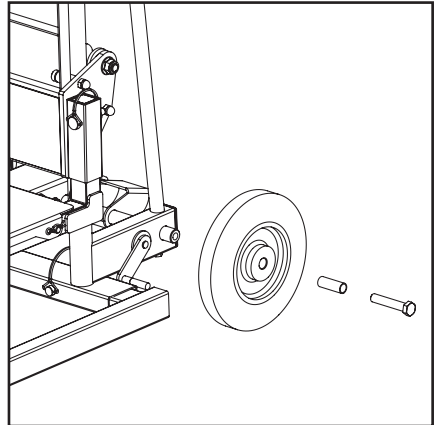

8.2 Universal Wheel Replacement

- a. Loosen the four M5 locknuts first, then remove the universal wheel.
- b. After replacing the universal wheel, tighten the four M5 lock nuts.

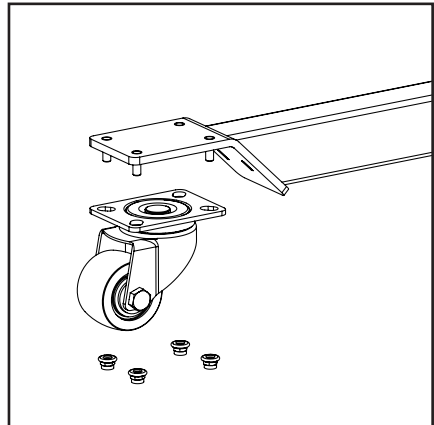

8.3 Pulley replacement

- a. Remove the retaining ring from the pin, and then pull out the pin.
- b. Using the new pulley, place the polyethylene rope in the groove of the pulley and place the pulley at the installation position, put the pins in order and use the tool to put the retaining ring into the pins to complete the replacement of the pulley.

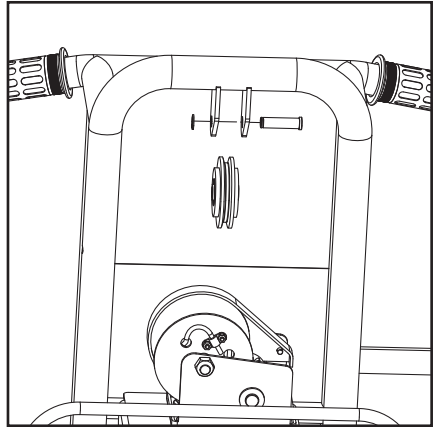

8.4 Flat plate replacement

- a. Adjust the fork (including the plate) to a convenient operating height.
- b. Take out the R-Pins on both sides and remove the flat plate respectively.
- c. Place the replacement plate on the forks and insert the R-Pins into the pin holes of the forks and plate on both sides respectively (lock them) to complete the plate replacement.

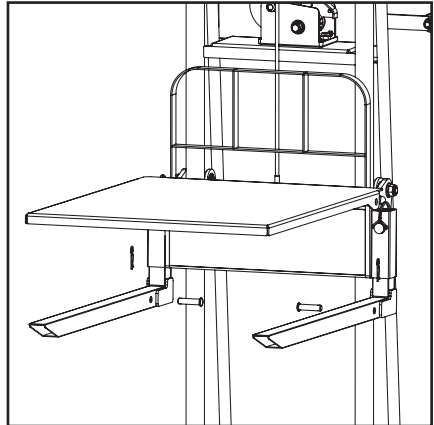

8.5 Fork replacement

- a. Remove the D-pins from each side and pull out the forks in the downward direction.
- b. Insert the new fork into the mounting interface and insert the D-pins into the pin holes and lock them respectively.
- c. Replace the fork on the other side according to the above steps.

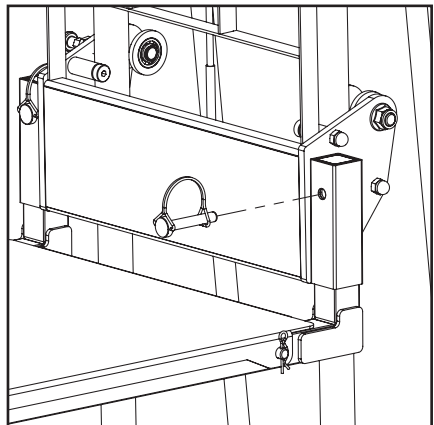

8.6 Polyethylene rope replacement

Note: Before replacing the polyethylene rope, make sure the fork in the lowest position, for safety reasons, it is recommended to make the polyethylene rope in the loose state.

a. Disassembly of polyethylene rope.

① Disassembly of polyethylene rope and support plate: first unscrew the nut, pull the wire rope with your hand, and pull out the screw with the other hand.

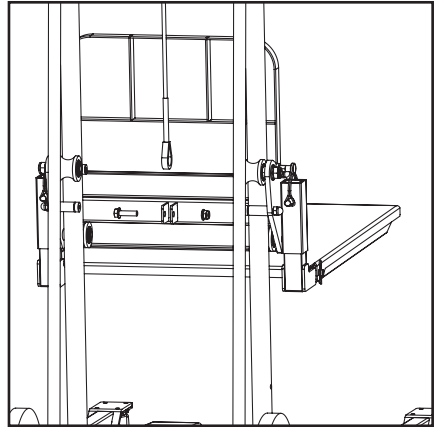

② Disassembly of polyethylene rope and winch.

- Loosen the 2 nuts first and remove the platen.
- The polyethylene rope in turn from the winch hole C, hole B and hole A pull out, pull out the process needs to be operated carefully to avoid the elasticity of the polyethylene rope injury.

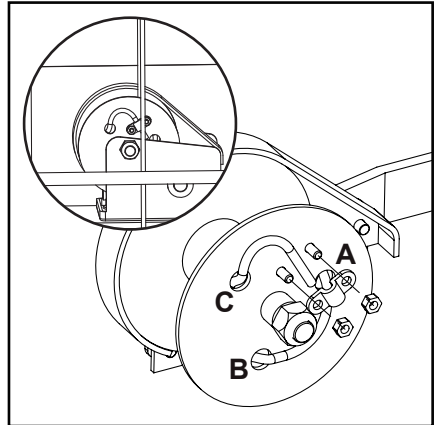

- Remove the polyethylene rope from the winch shaft and pull it out from the pulley to complete the removal of the polyethylene rope.

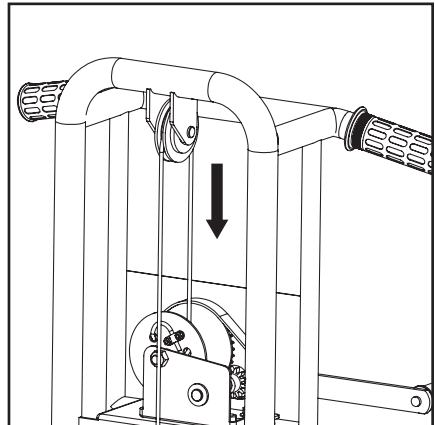

b. Installation of polyethylene rope.

① Installation of polyethylene rope and winch.

- First insert the polyethylene rope (unbuckled end) into the groove of the pulley first.
- Thread the polyethylene rope through hole A (inside-out), hole B (outside-in) and hole C (inside-out) of the winch in turn and place the end of the polyethylene rope between the two screw holes.
- Two screws into the screw holes (from inside to outside), the pressure plate into the screws and press the polyethylene rope, tighten the nut, complete the polyethylene rope and winch installation.

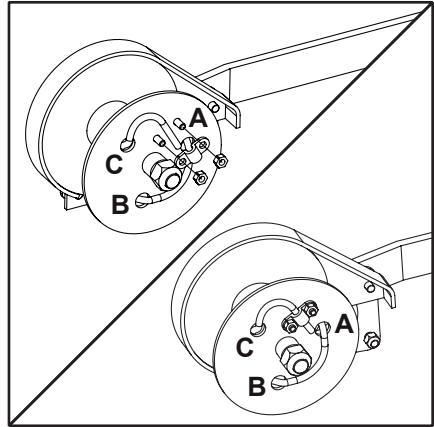

- ② Polyethylene rope and support plate installation: the fork is in the lowest position, pull the other end of the polyethylene rope by hand, so that the press button through hole and the support plate installation hole concentric alignment, screws into the hole and lock the nut, that is, the completion of the installation of polyethylene rope.

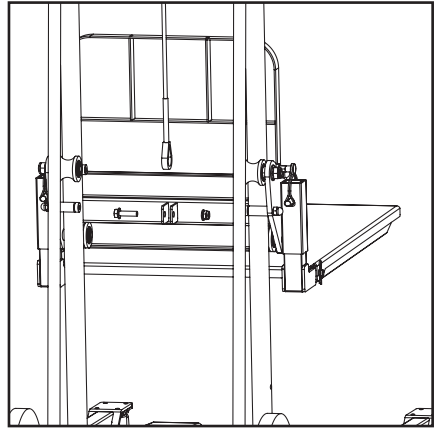

9. TRANSPORTATION&STORAGE

1. When storing the product, it should be stored in a cool, dry and dust-free place, avoiding direct sunlight and rain.
2. When transporting, loading and unloading the products, it is strictly prohibited to throw, drop, throw, and trample and other barbaric operations.

10. WARRANTY

Twelve (12) months for workmanship of the product, except for wearing parts. Warranty period starts from the product purchase date. Warranty covers material quality and workmanship only. Warranty does not cover product for issues caused by improper usage or any operation not in accordance with the specifications of this manual. Any modification or tampering with the product in any way voids the warranty.

11. TROUBLE SHOOTING

1. Normal maintenance and regular servicing will extend the life of the equipment.
2. The following troubleshooting guide lists the most common problems, causes and solutions.

Problem(s)	Possible Cause	Corrective Action
Abnormal noise or jamming when the winch handle is rotating.	<ol style="list-style-type: none">1. Foreign objects on the polyethylene rope.2. Polyethylene rope breakage.3. Roller damage.4. Sliding rail with foreign objects.5. Slide rail roller damage.6. Star bolt is not disengaged.	<ol style="list-style-type: none">1. Clear the foreign body of the polyethylene rope.2. Replace the polyethylene rope.3. Replace the roller.4. Remove foreign objects from the slide rail.5. Replace the slide rail roller .6. Star bolt dislodged.
The lift does not move smoothly or has strange noises.	<ol style="list-style-type: none">1. Universal wheel damage.2. Directional wheel with foreign objects.	<ol style="list-style-type: none">1. Replace the universal wheel.2. Removal of foreign bodies.

12. EXPLODED VIEW AND PARTS LIST

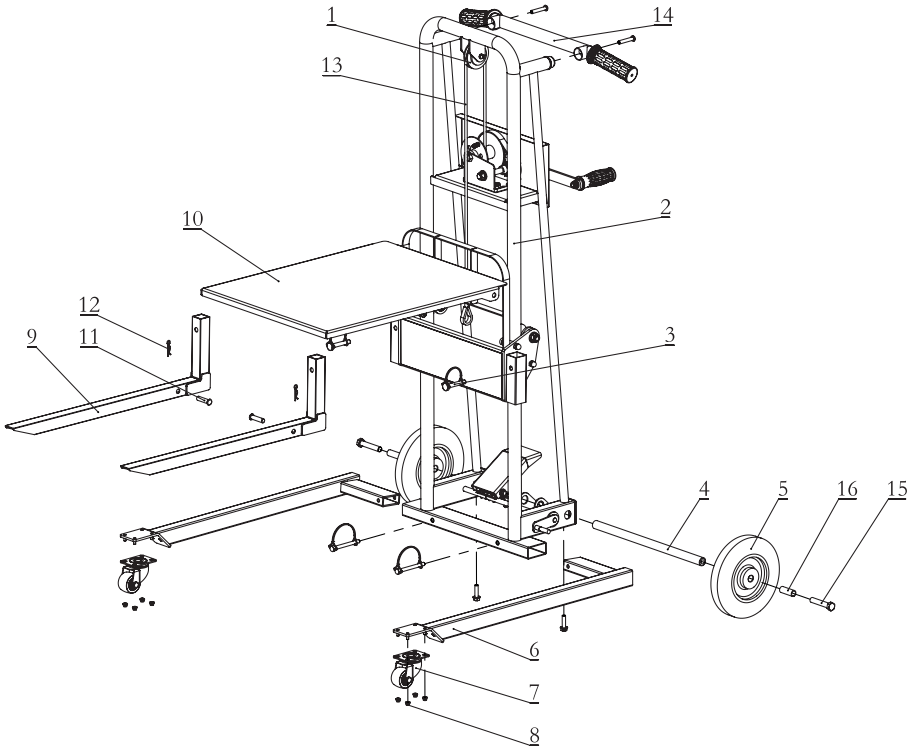

Part No.	Description	Q'ty	Part No.	Description	Q'ty
1	Polyethylene rope pulley	1	9	Fork	2
2	Primary frame	1	10	Flat plate	1
3	D-pin	6	11	Pin	2
4	Wheel Axle	1	12	R-pin	2
5	Directional wheel	2	13	Polyethylene rope	1
6	Wheel carrier	2	14	Handlebar	1
7	Universal wheel	2	15	Hexagon Bolt M12x65	2
8	Nut M5	8	16	Bushing	2



Great Circle USA

Email: service@greatcircleus.com

www.greatcircleuk.com

www.greatcircledede.com