

# Intel 1500 LED TV Cabinet

## Wireless Charging

### Assembly Instructions

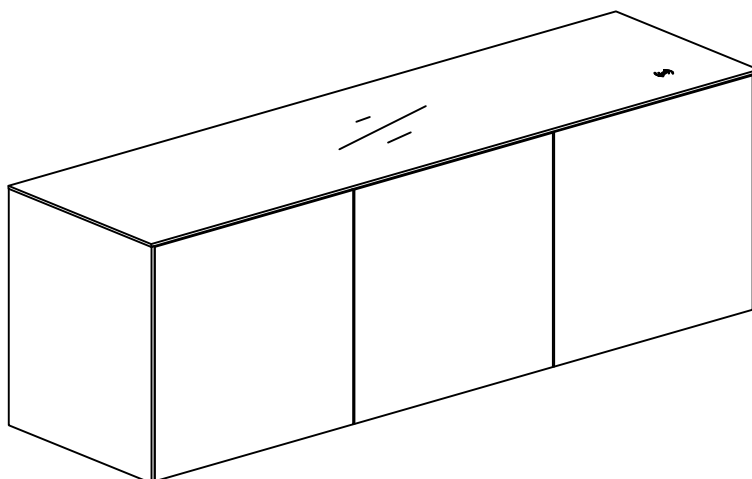

NOTE : If you have any problems or feel the need to return the product, Please contact us first so that we can try our best to help resolve your issue as quickly as possible. [support@frankolsenfurniture.co.uk](mailto:support@frankolsenfurniture.co.uk) 0800 689 5054

NOTE :  
we recommend watching the quick assembly help and tips guide video before assembling.



To watch assembly video :  
[www.frankolsenfurniture.co.uk](http://www.frankolsenfurniture.co.uk)









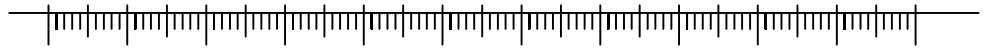





Download the Frank Olsen Smart app from :  
Google Play store or Apple store

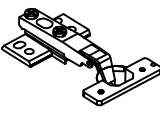
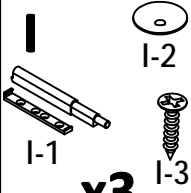

# HARDWARE

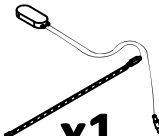
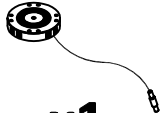
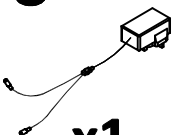
0 5 10 15 20 25 30 35 40 45 50 55 60 65 70 75 80 85 90 95 100 105 110 mm

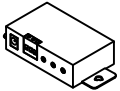

<b>A</b> $\Phi 8*30$  <b>x24</b>	<b>B</b> $\Phi 8*38$  <b>x24</b>	<b>C</b> $\Phi 15*12$  <b>x24</b>	<b>D</b> M6*30  <b>x12</b>	<b>E</b> M3*12  <b>x1</b>	<b>F</b> M3.5*14  <b>x44</b>	<b>G</b> M3.5*16  <b>x8</b>
<b>H</b>  <b>x6</b>	<b>I</b>  <b>x3</b>	<b>J</b>  <b>x12</b>	<b>K</b>  <b>x8</b>	<b>L</b>  <b>x8</b>	<b>M</b>  <b>x1</b>	<b>N</b>  <b>x1</b>
<b>O</b>  <b>x1</b>	<b>P</b>  <b>x1</b>	<b>Q</b>  <b>x1</b>	<b>R</b>  <b>x2</b>	<b>S</b>  <b>x2</b>		

 Tools Required-Not Supplied

# PARTS

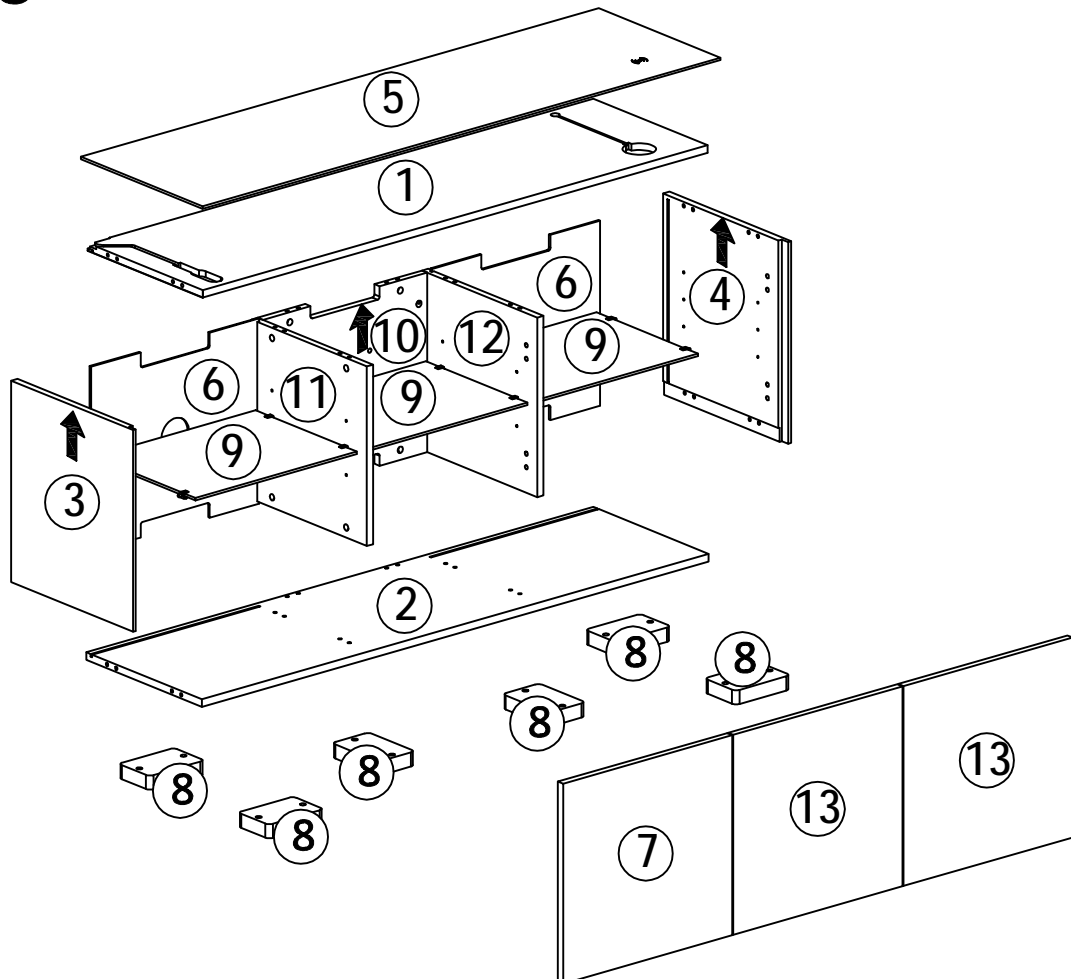

# 1

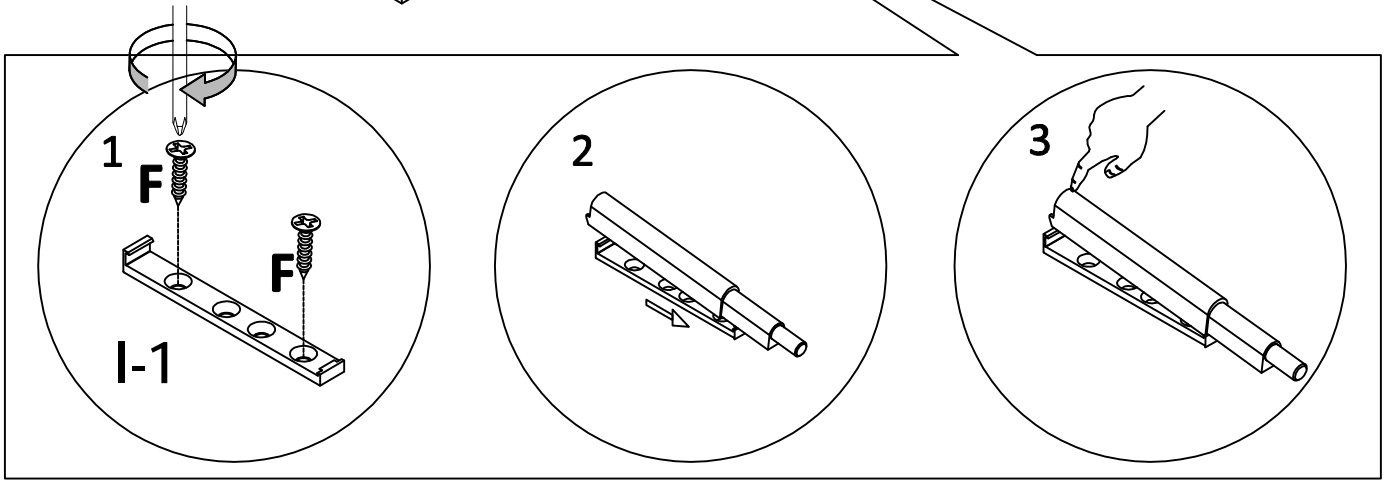
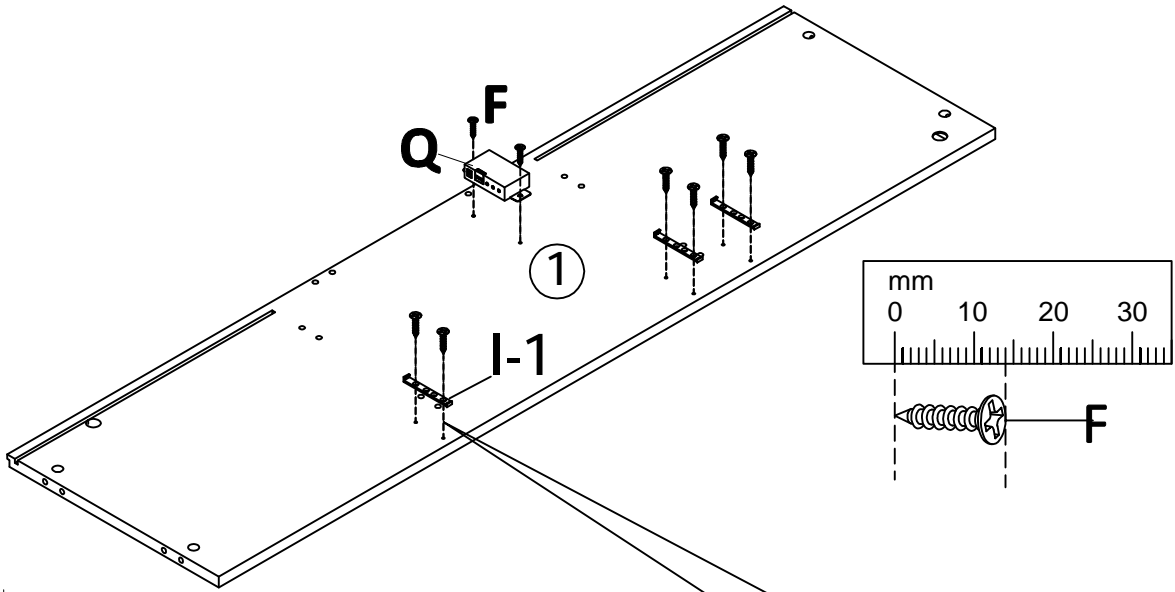

## 2 Guide on using quick cam assembly

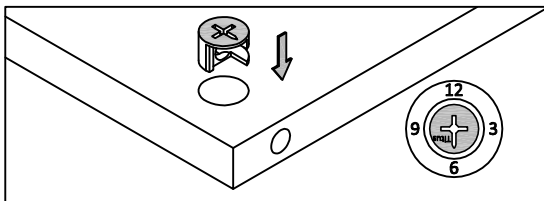

1. Press cam into pre-drilled hole with the arrow pointing toward the side hole. ( see 6 O'clock. )

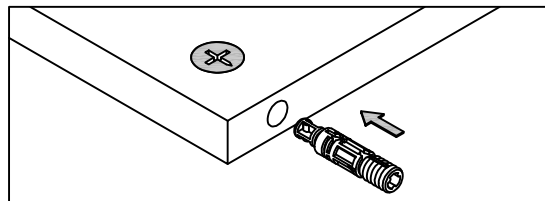

2. Push the bolt all the way into the side hole.

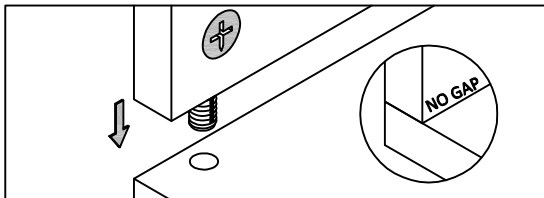

3. With all cam & bolts installed align and push the panels together - NO GAPS ( MAKE SURE PANELS HAVE NO GAPS )

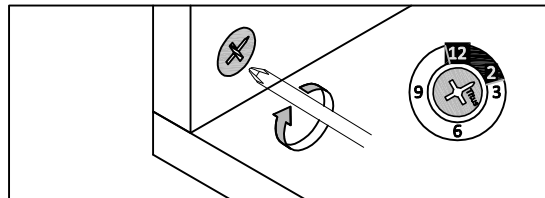

4. Turn cam clockwise to tighten. Secure connection by turning arrow on the cam to 2 O'clock to smoothly lock panels together.

# 3

NOTE: Please see the separate instructions provided to set this device up correctly.

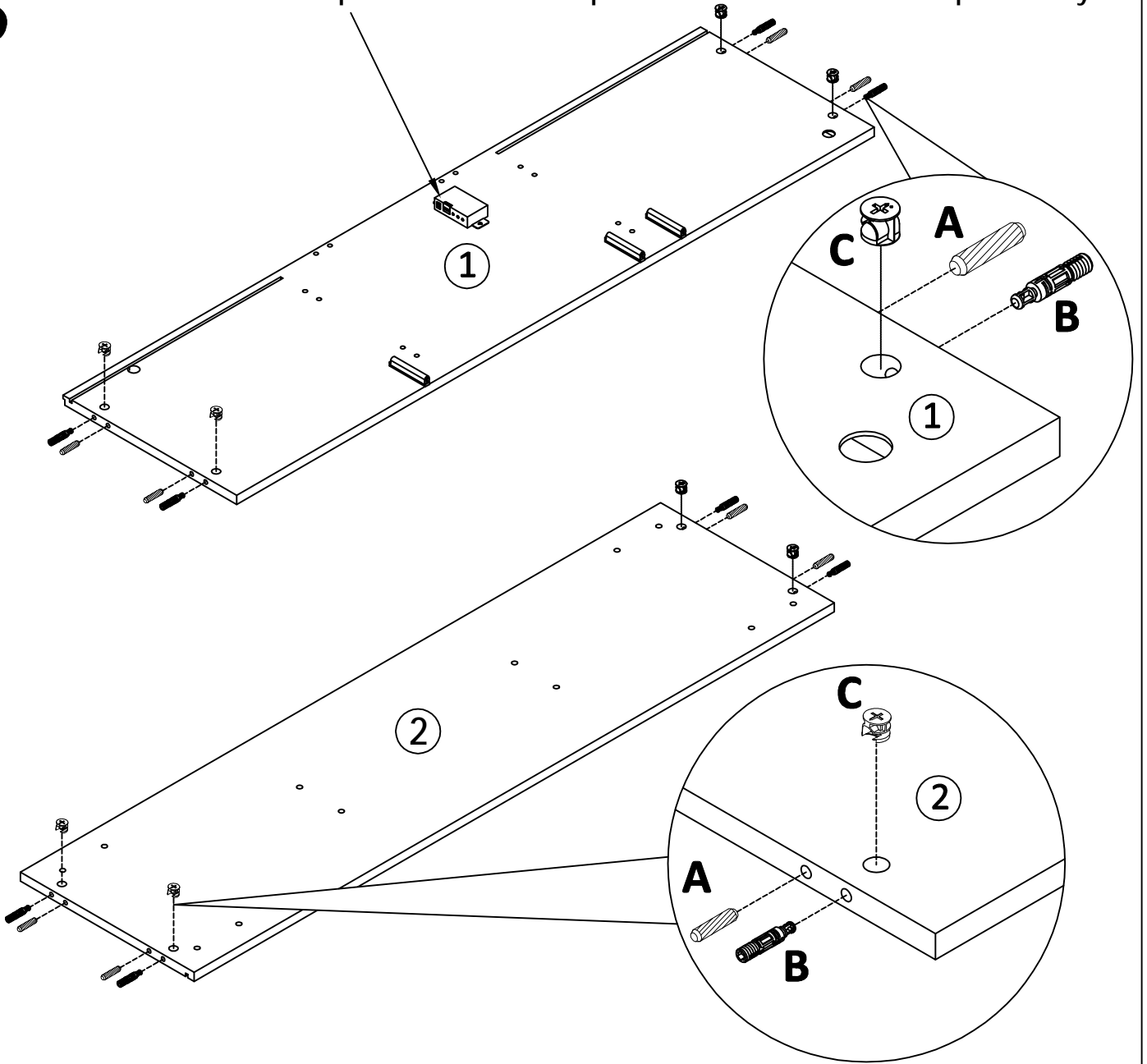

# 4

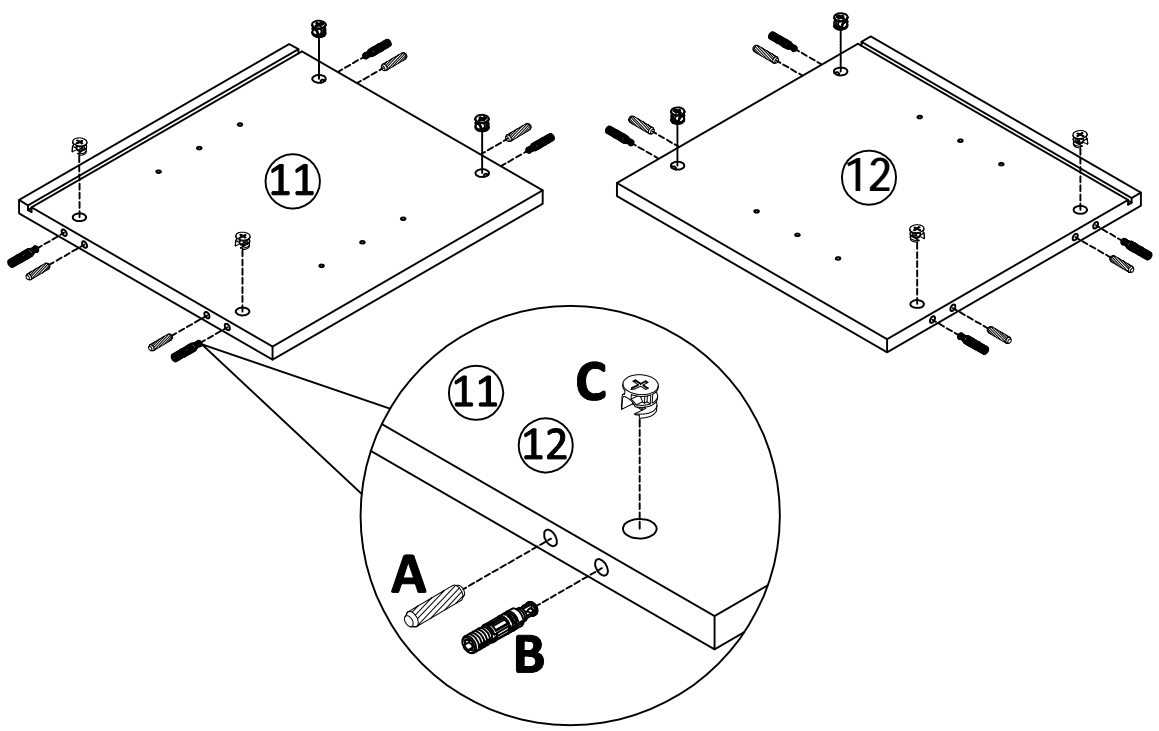

5

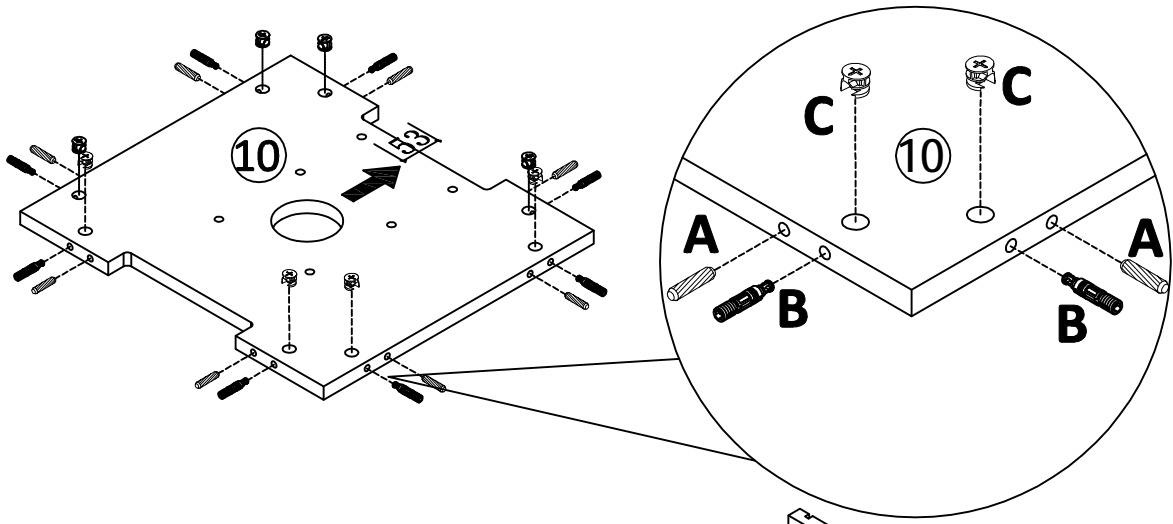

6

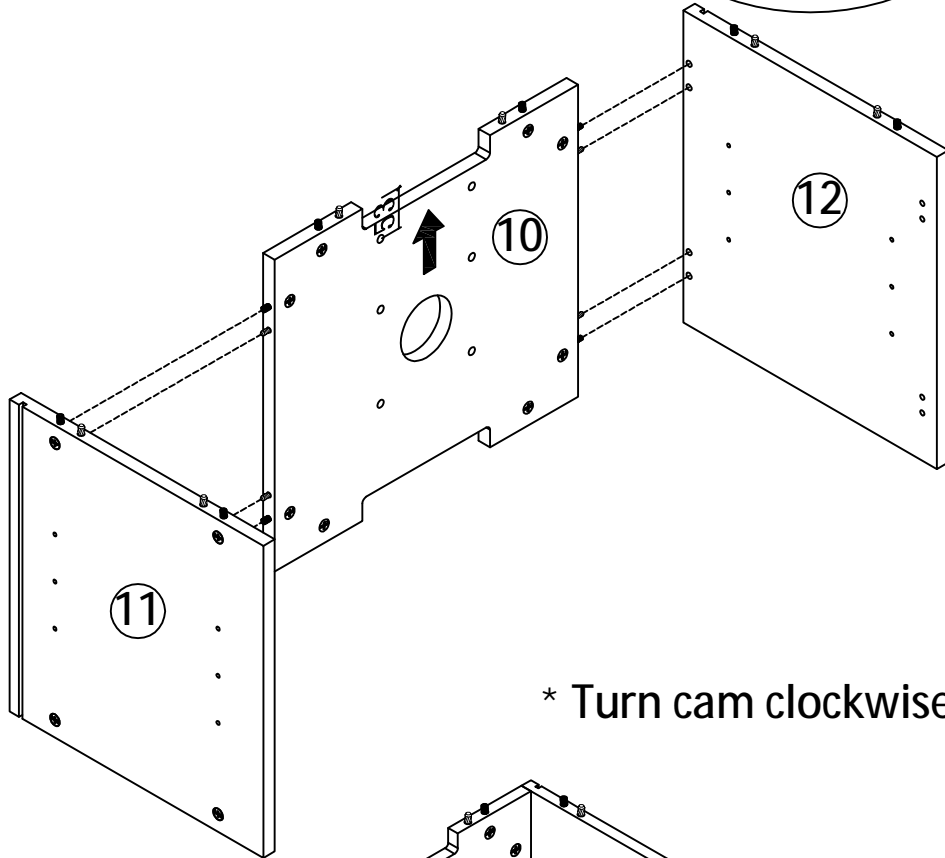

\* Turn cam clockwise to tighten

7

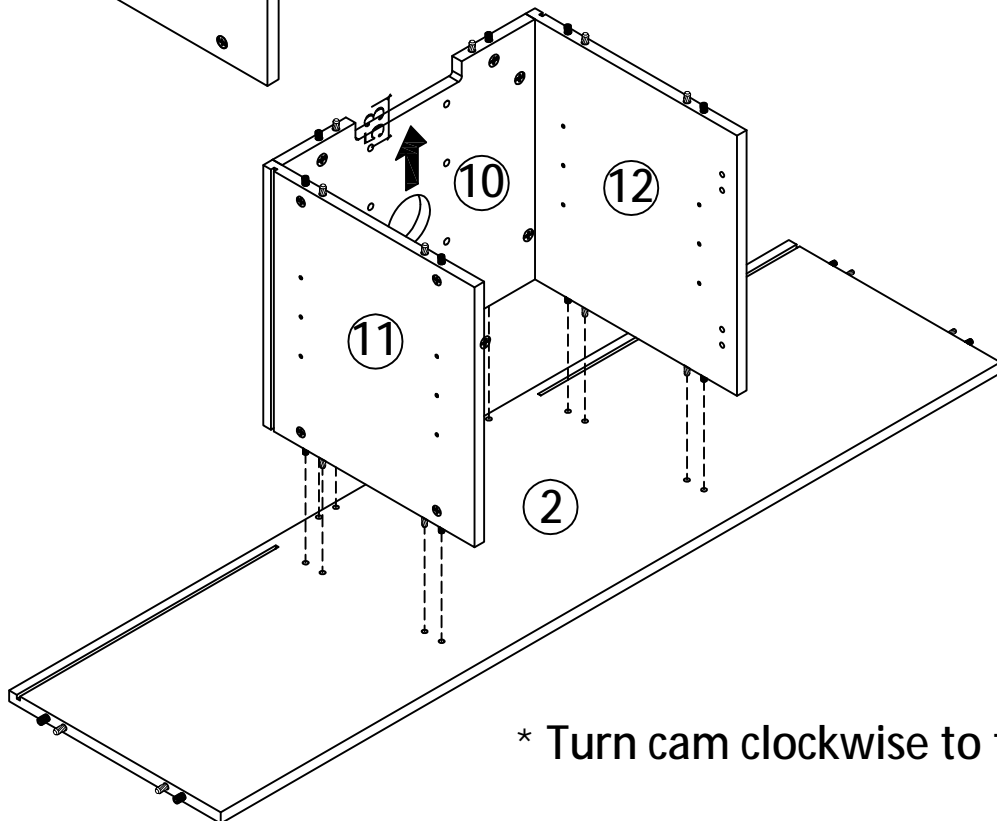

\* Turn cam clockwise to tighten

# 8

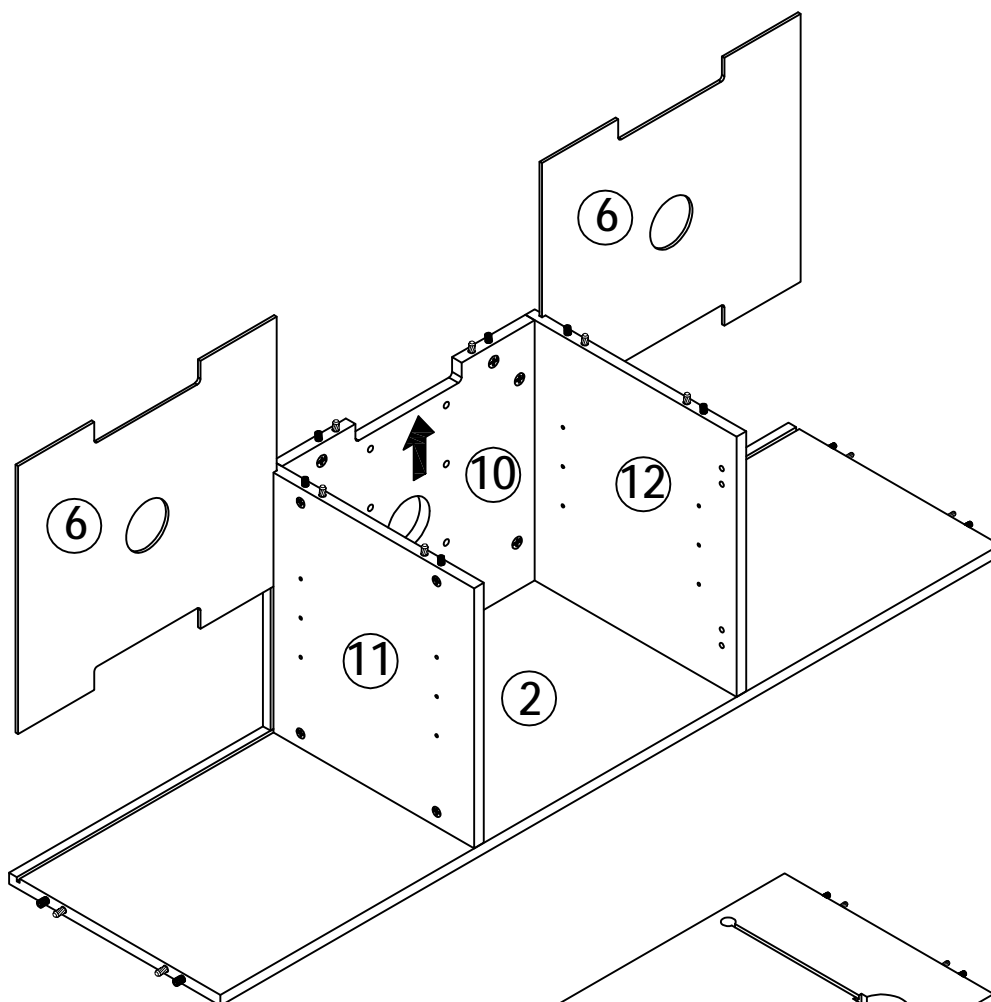

# 9

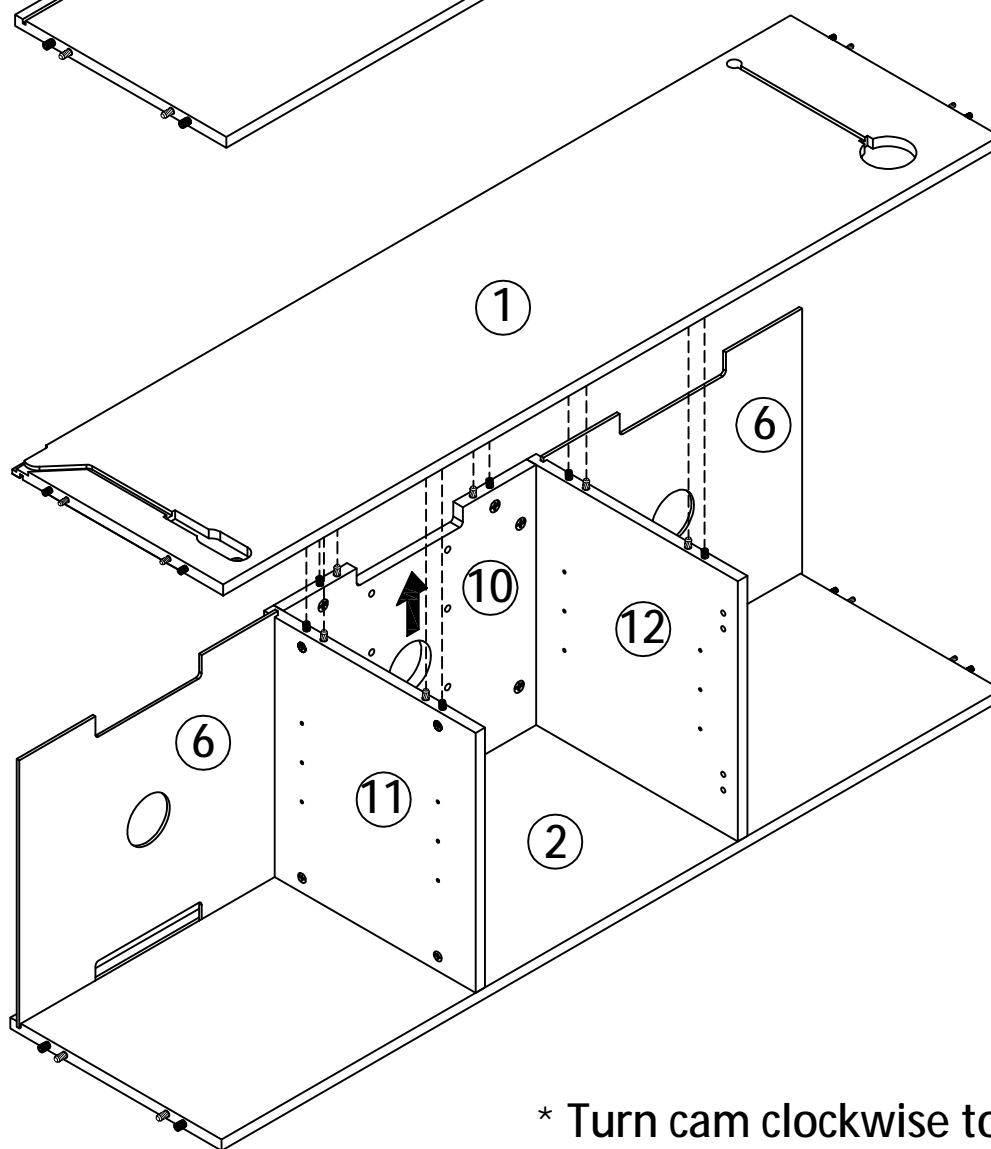

\* Turn cam clockwise to tighten

# 10

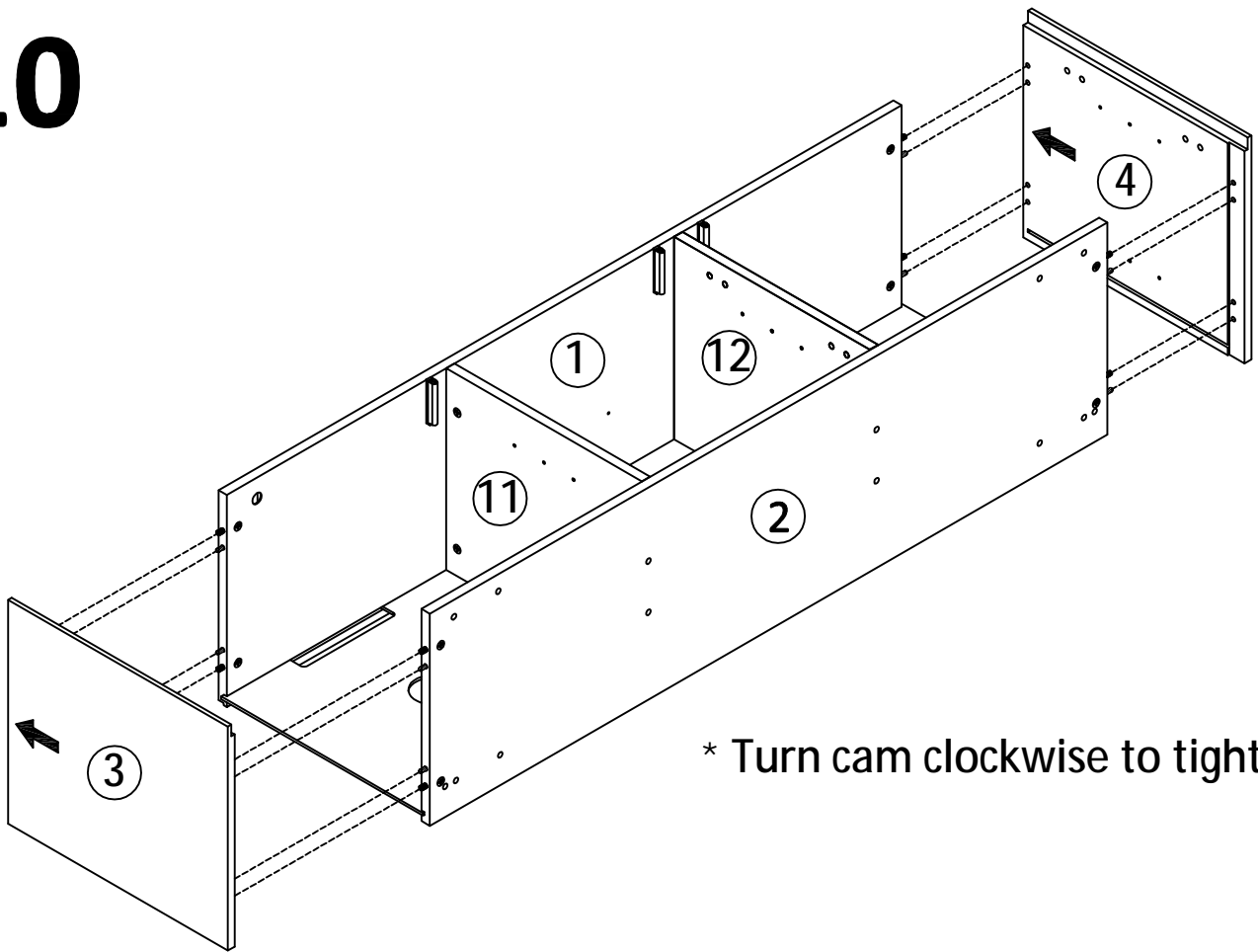

\* Turn cam clockwise to tighten

# 11

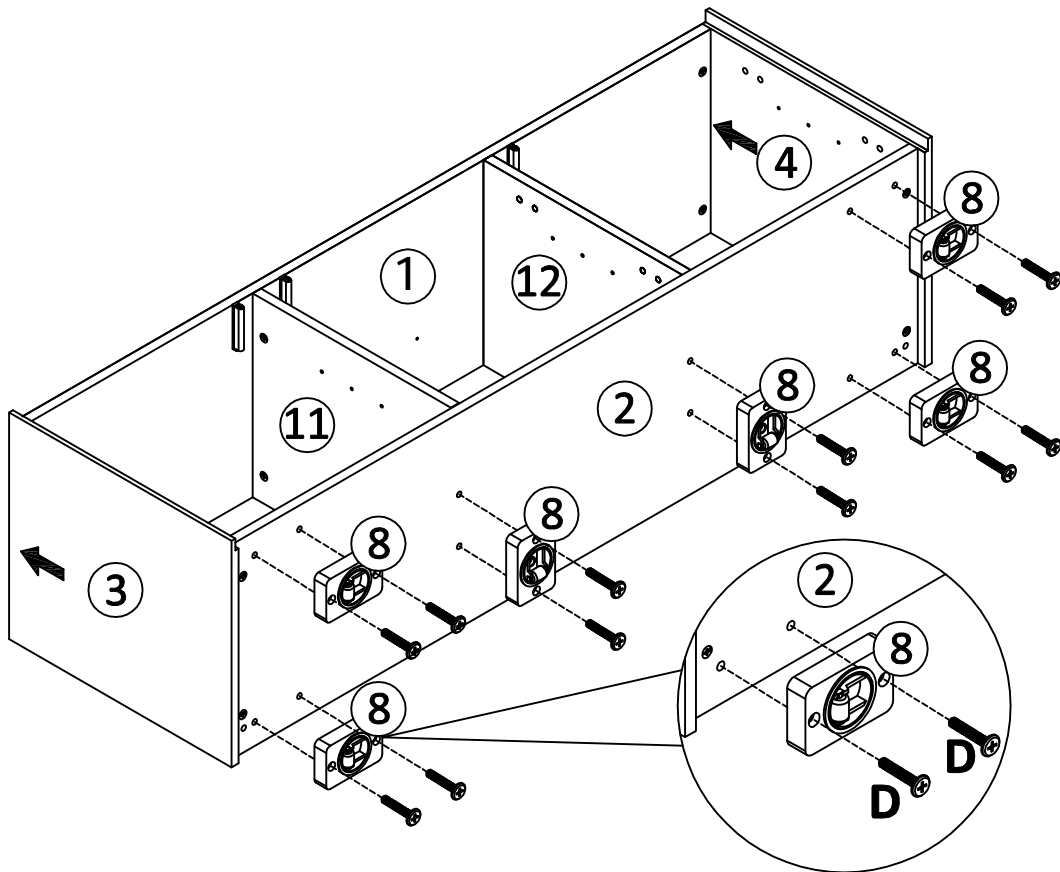

# 12

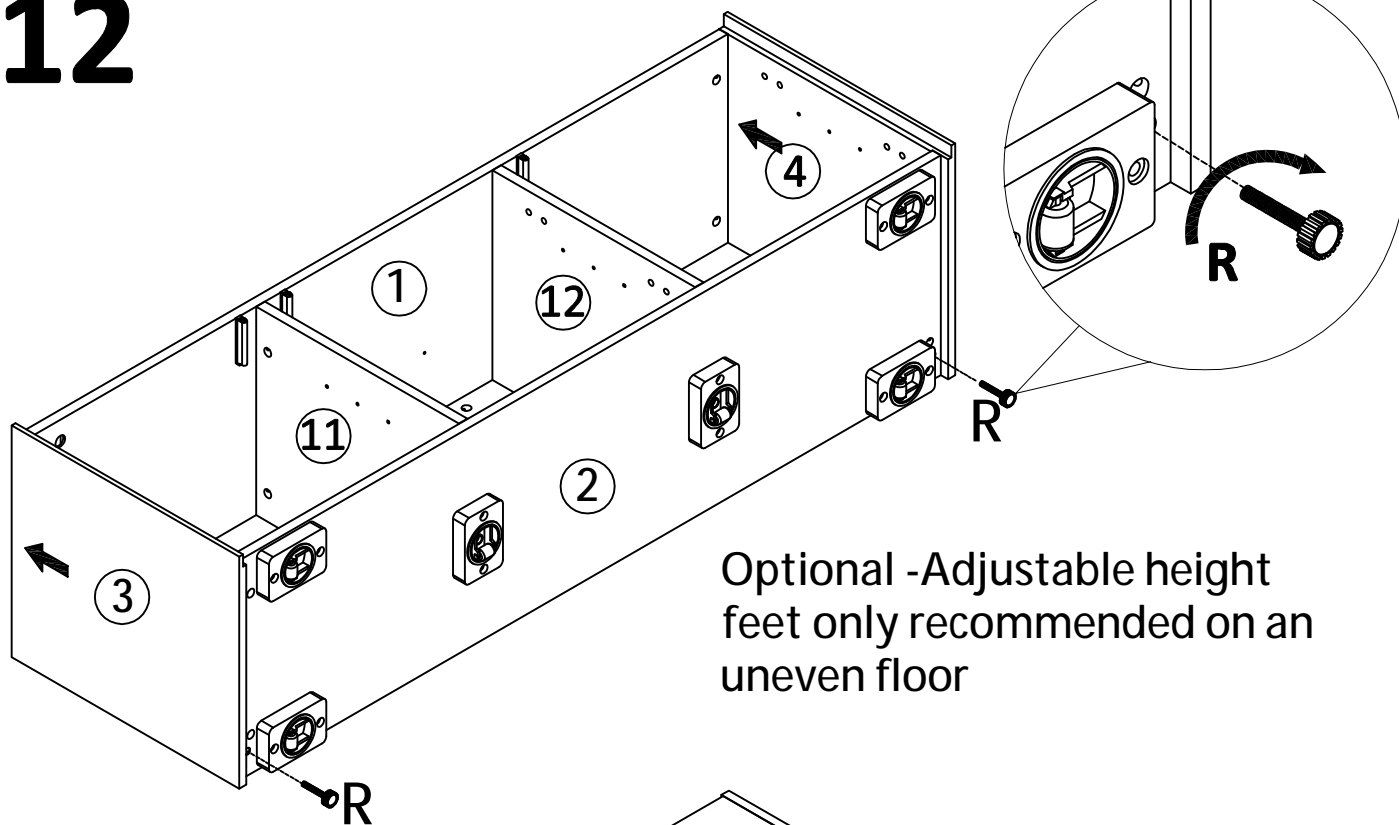

# 13

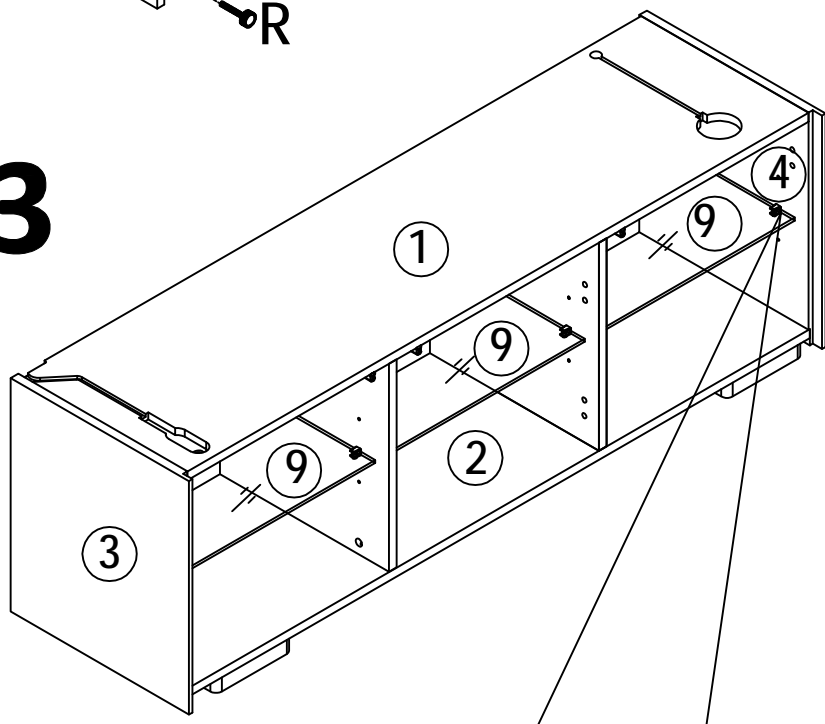

1.

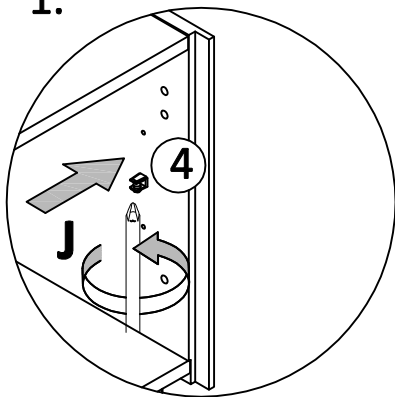

2.

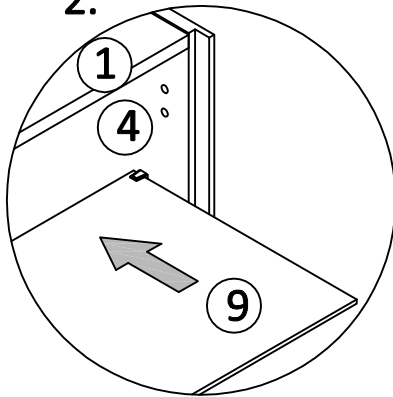

3.

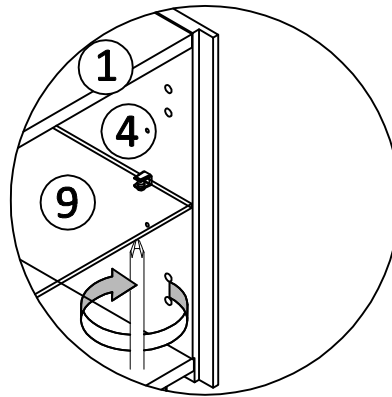

# 14

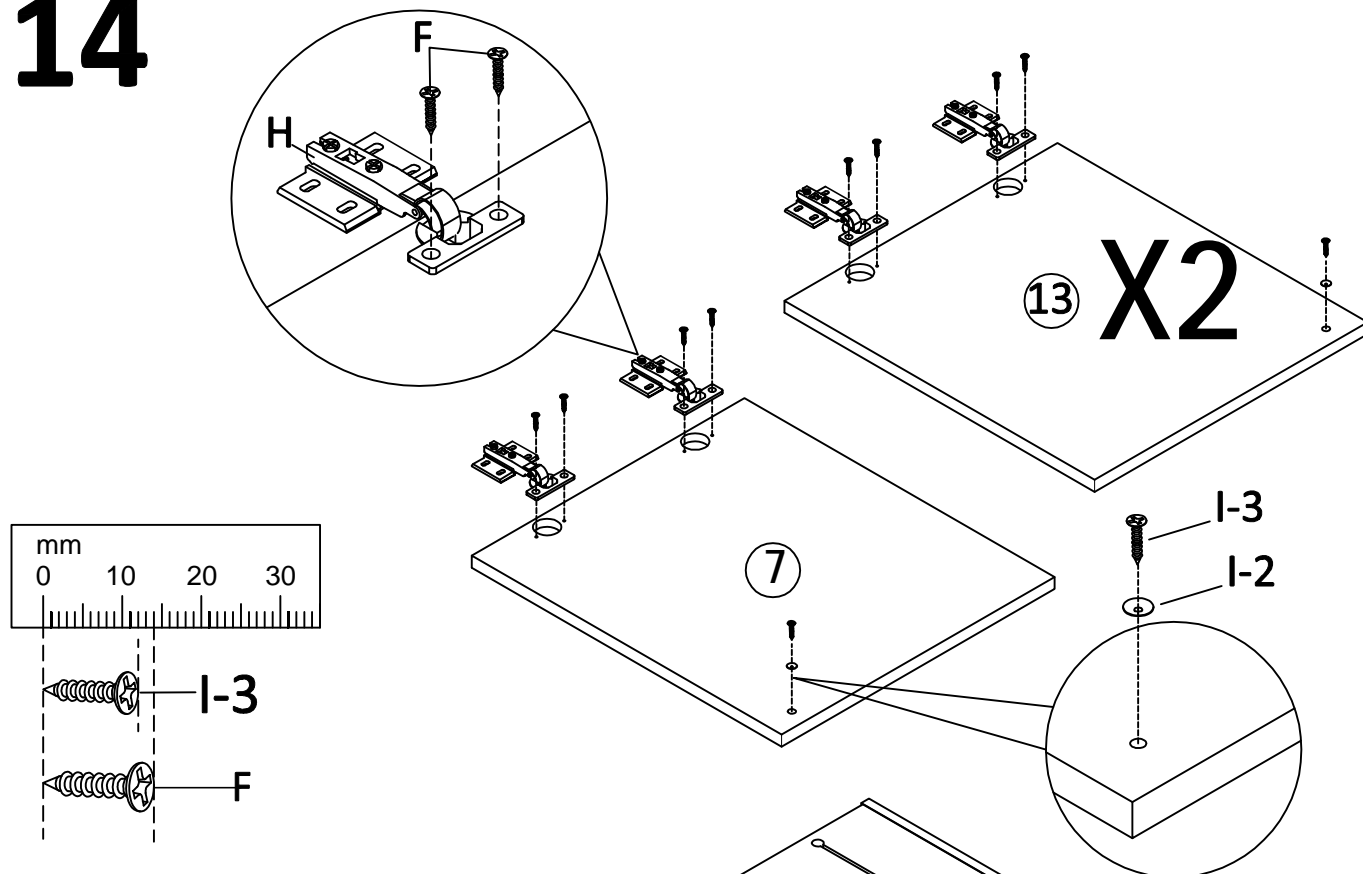

# 15

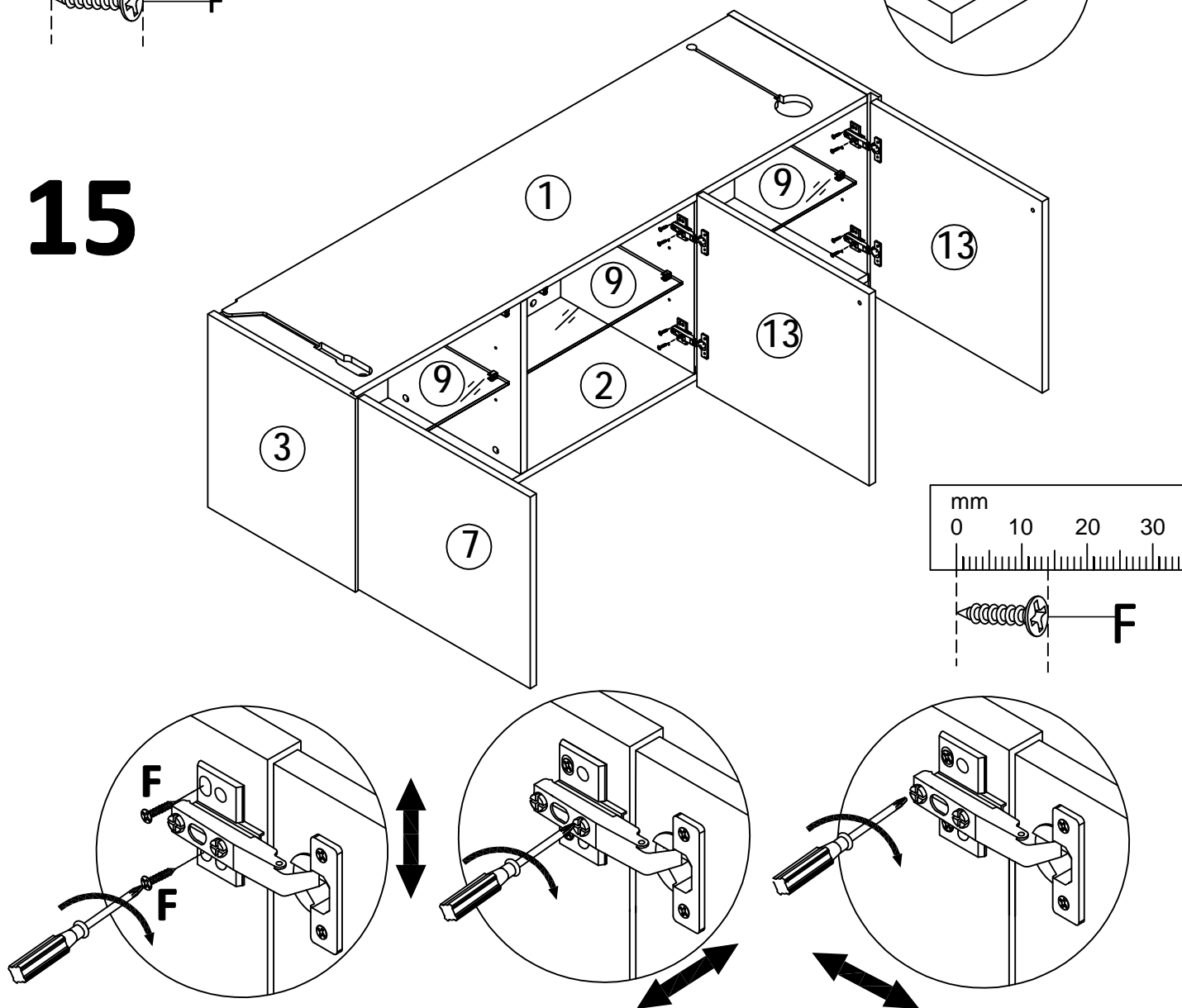

# 16

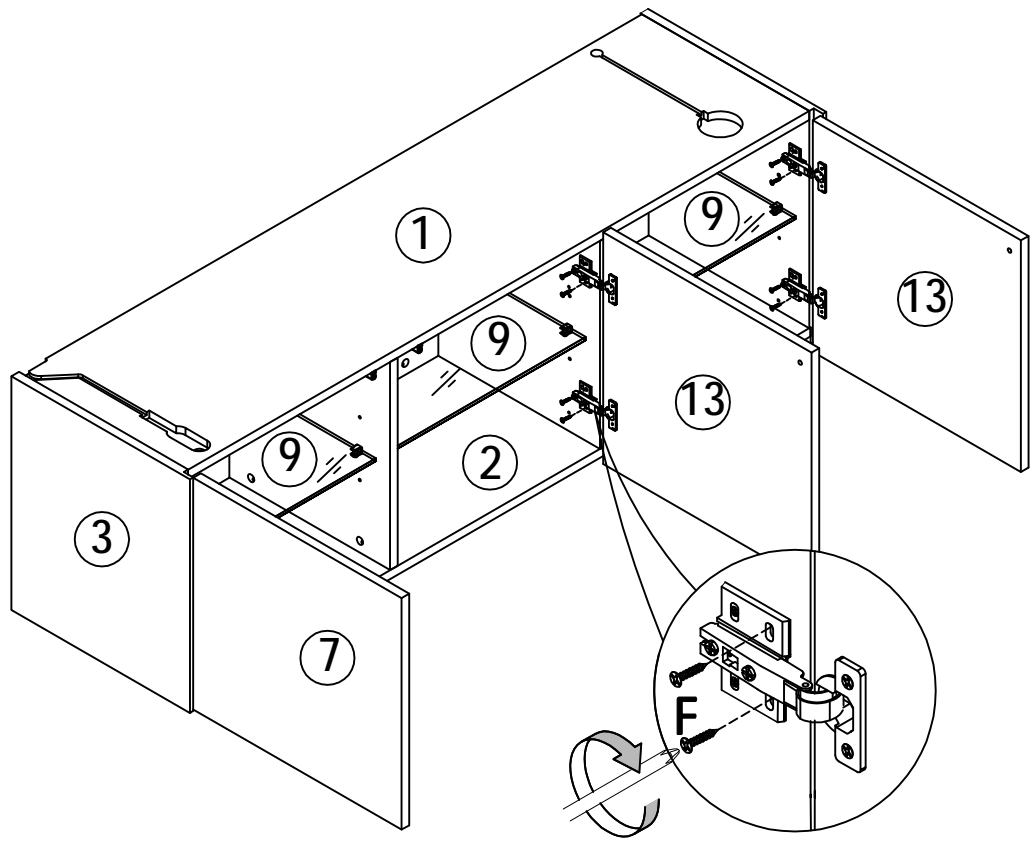

# 17

XX=YY

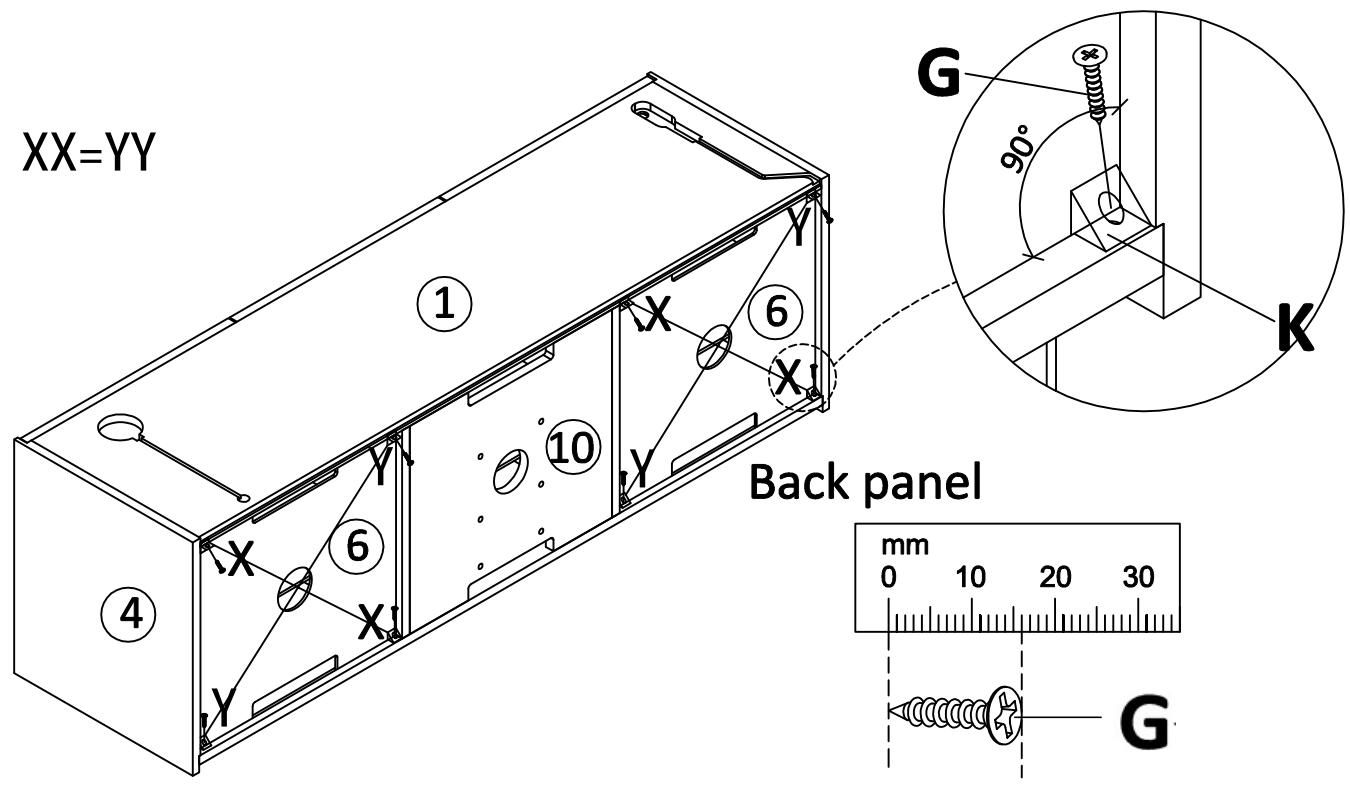

# 18

PLEASE FOLLOW THE STEPS TO ENSURE NO DAMAGE.

1. Screw in clip 'P'- ensure surface is DUST FREE

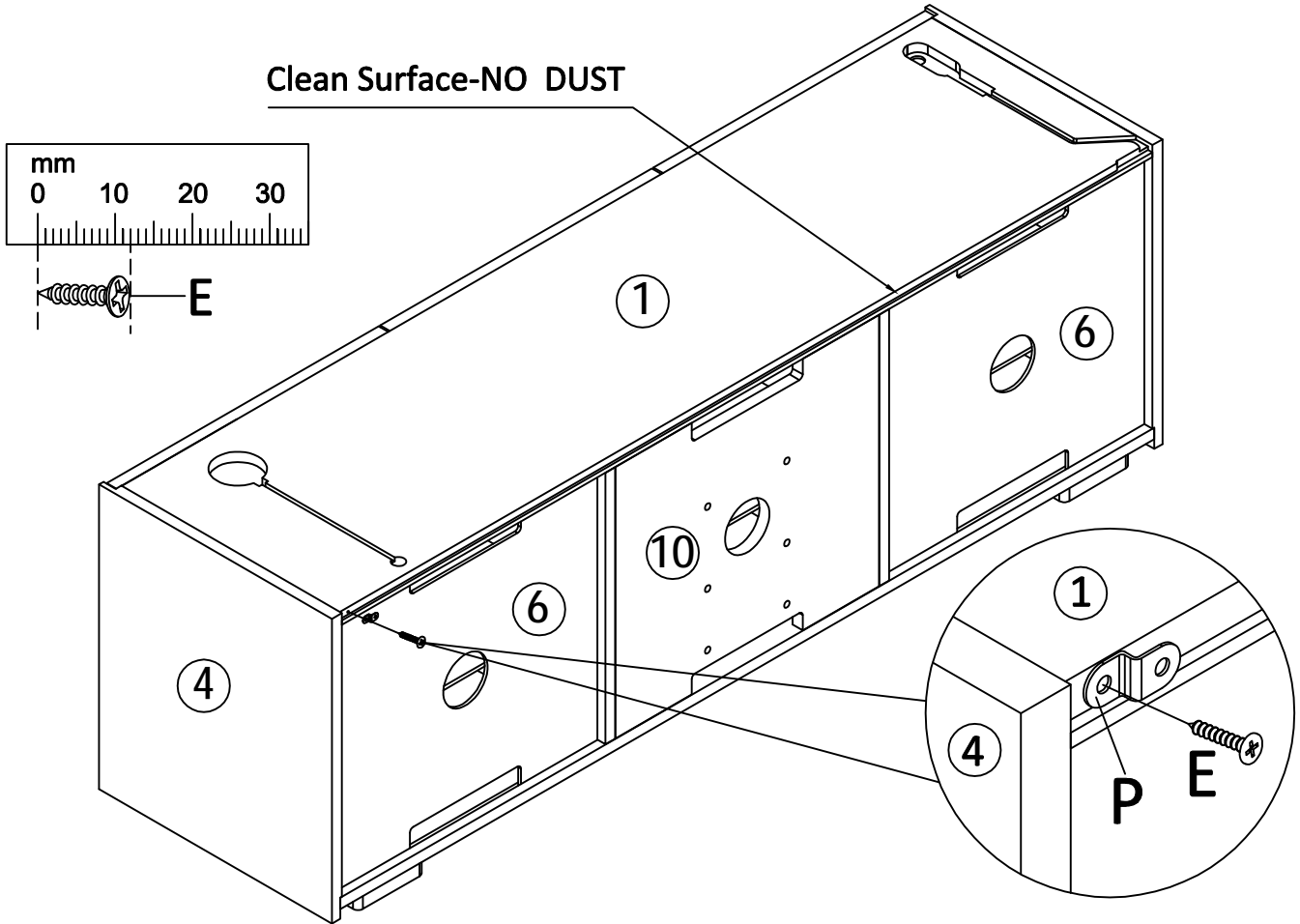

# 19

2. Do not remove LED strip backing yet. Place LED strip in position under the clip and lay LED strip in place.

3. Loosely run wires in the recess and place the button in position.

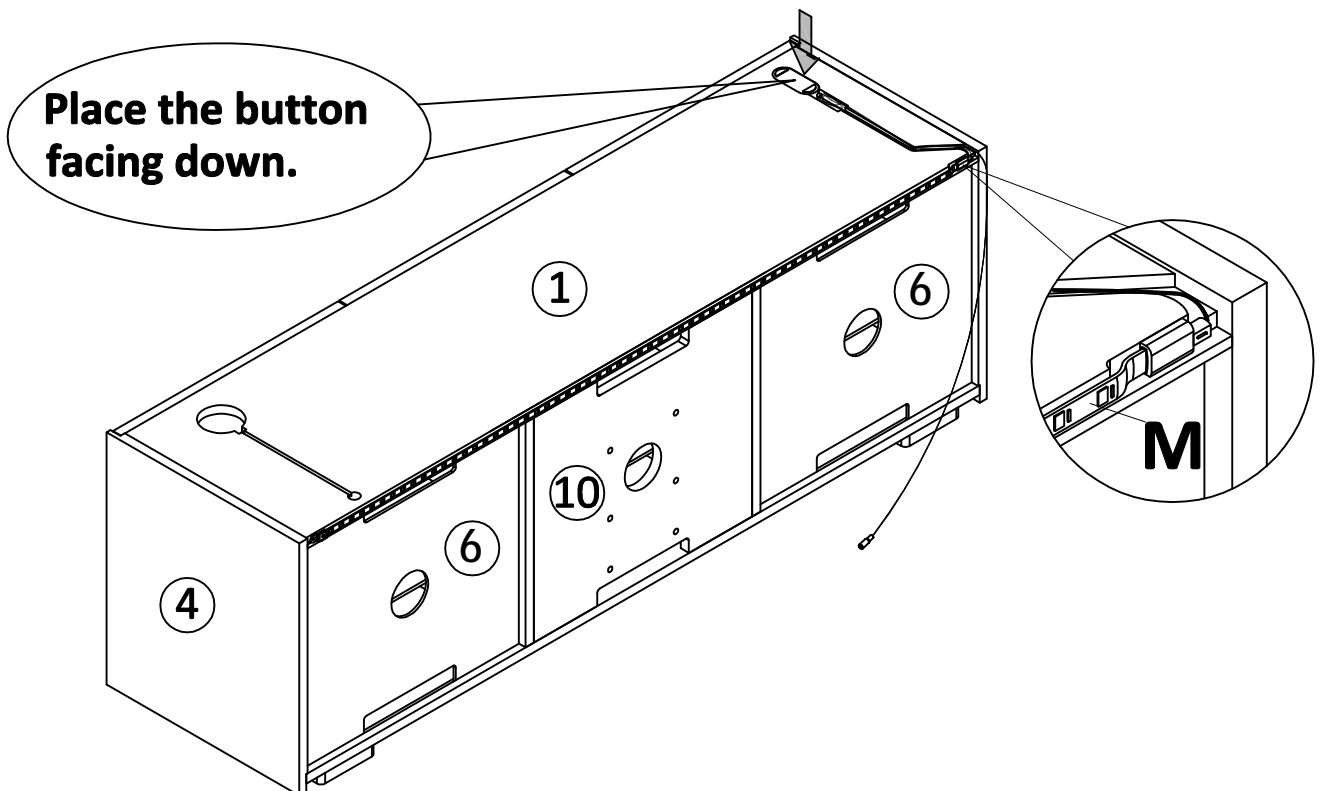

# 20

CAUTION, When peeling off LED adhesive strip, take Extra care to peel ONLY the protective strip, not the Adhesive strip.

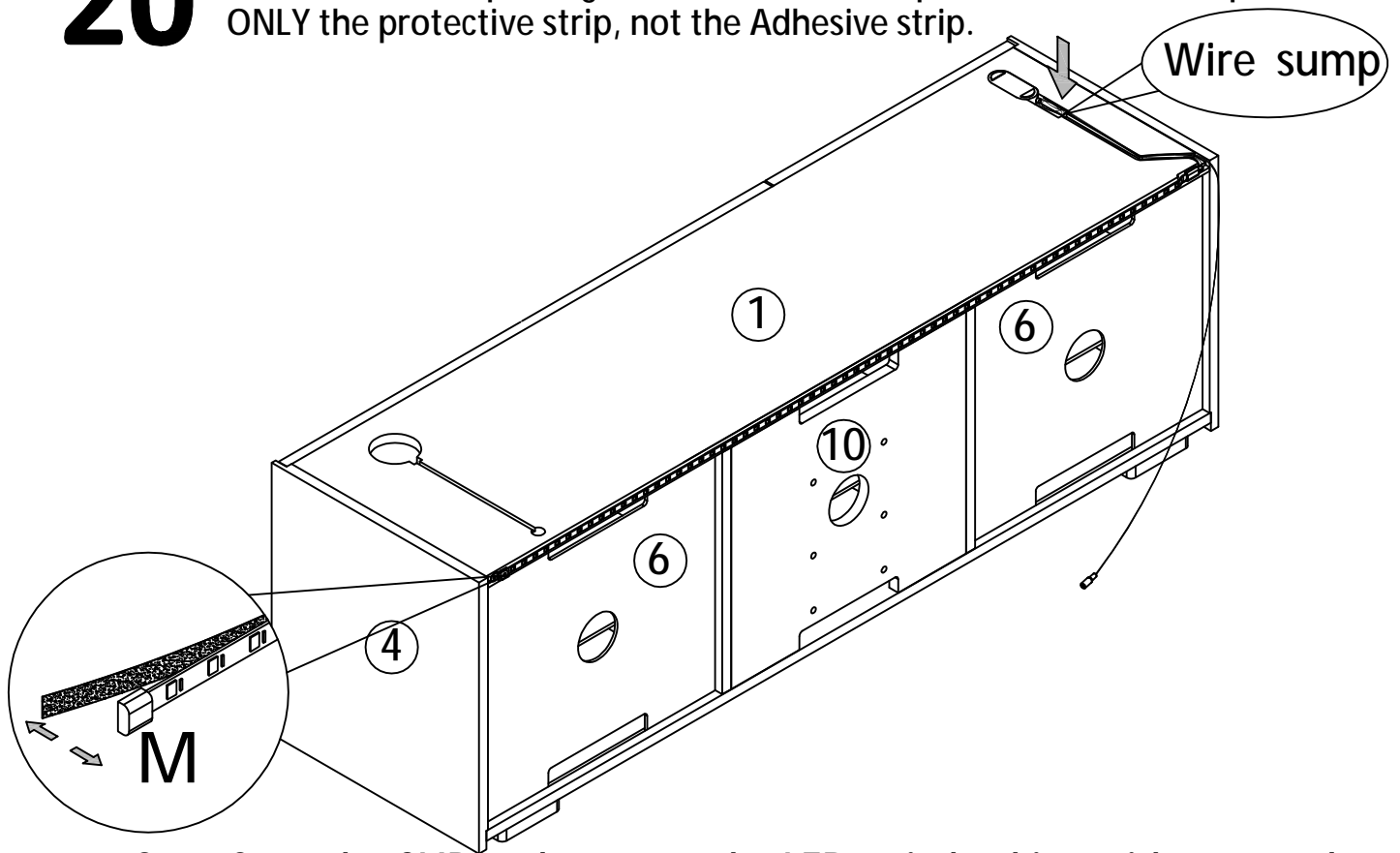

4. Start from the CLIP end, remove the LED strip backing with care and place in position on the edge of the back panel pressing firmly.
5. Gently pull the wires so that the end of the LED strip is straight and sticking in position.
6. Use the space in the wire sump to coil any excess wire for a neat fit.

# 21

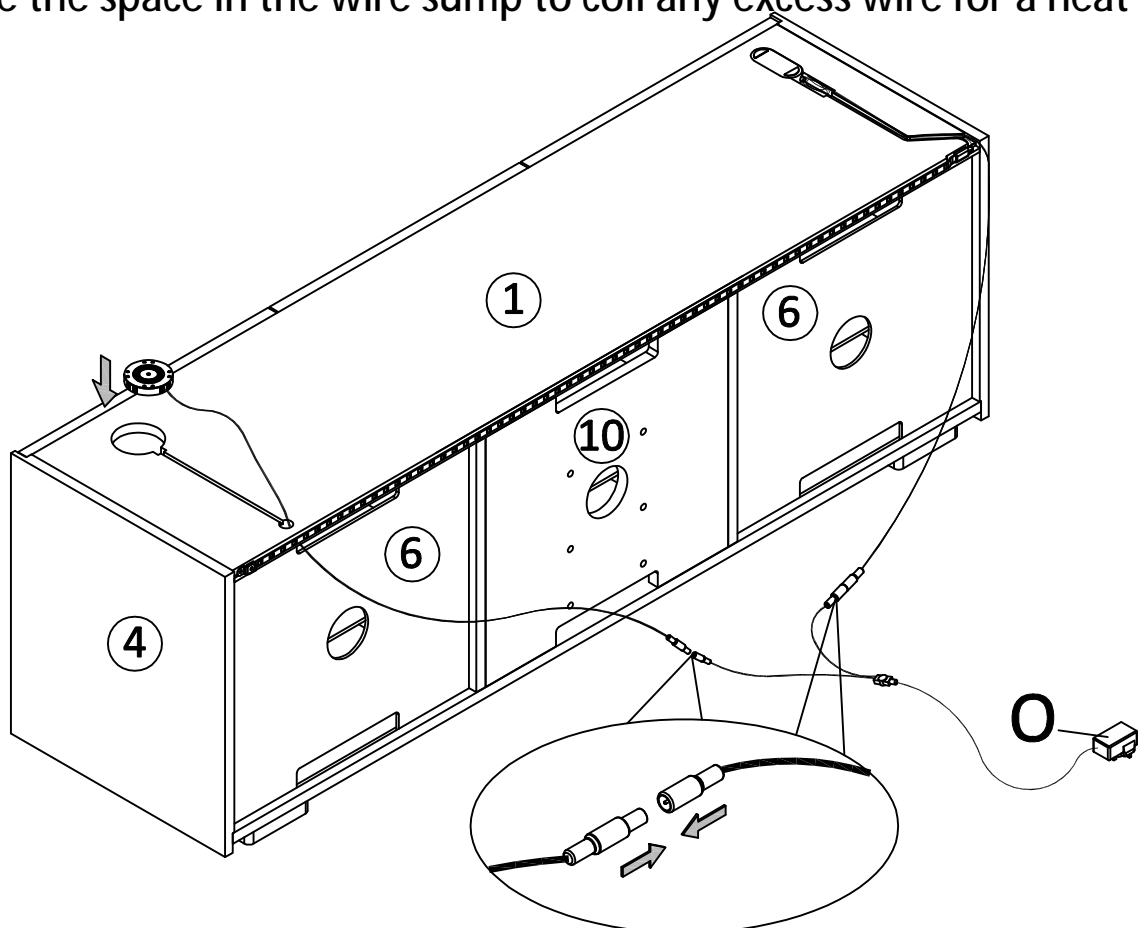

# 22

**NOTE : See separate instructions provided on setting up the app / LED strip and Alexa voice control.**

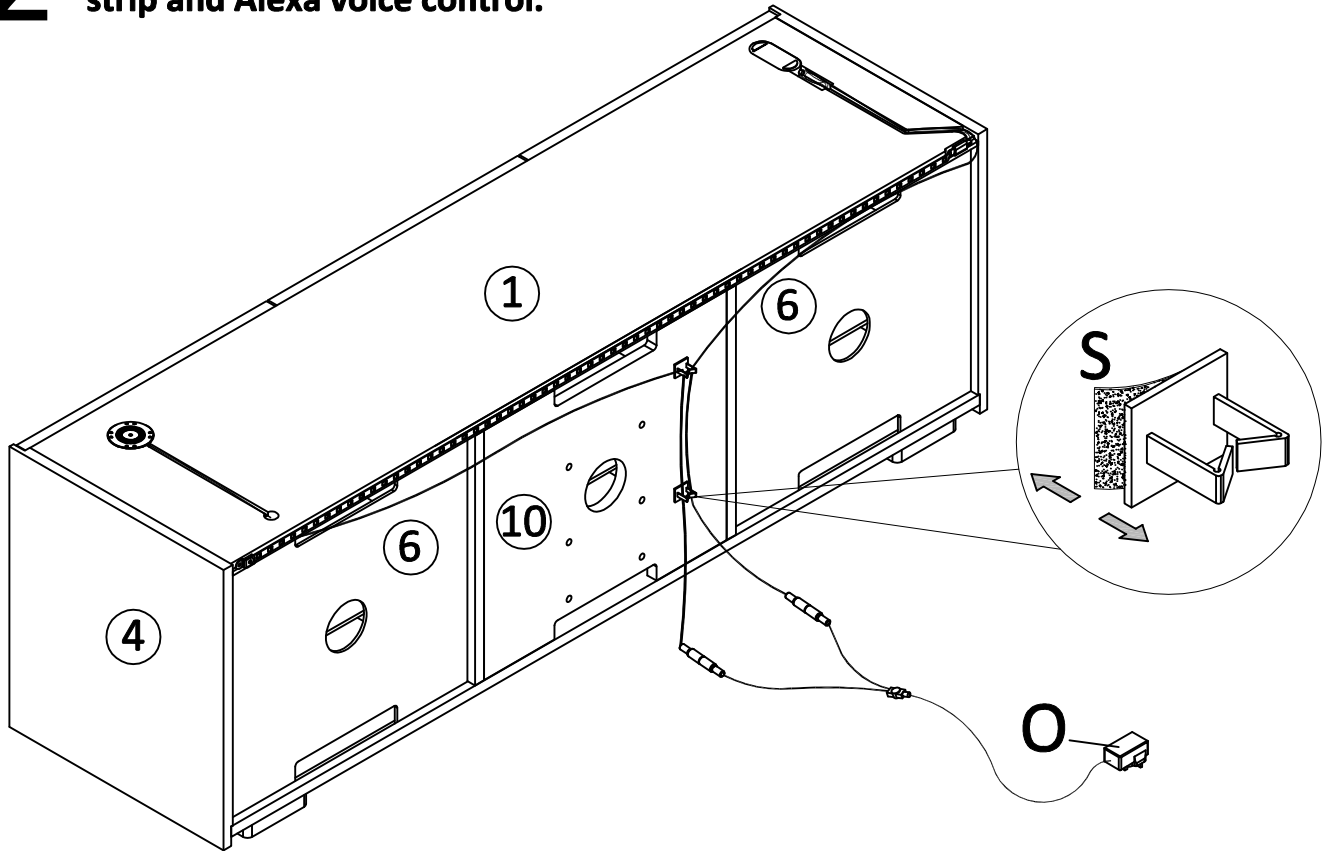

# 23

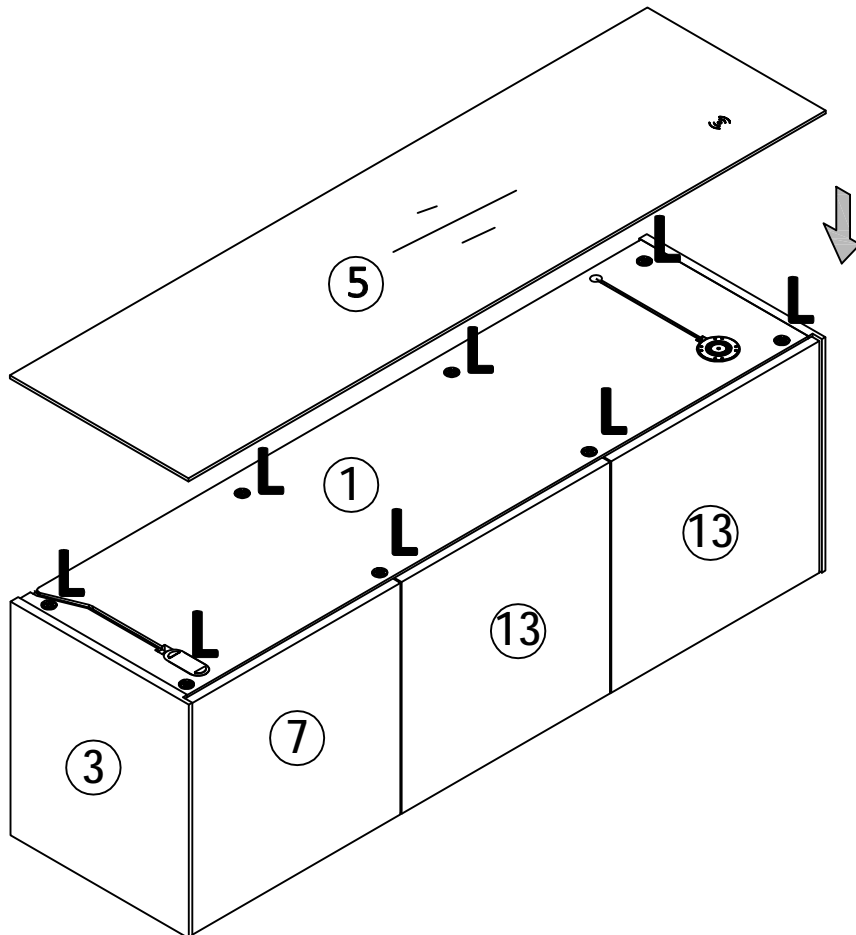

# 24

**NOTE: If the push to open mechanism is not working properly, Simply turn the end of the barrel to adjust.**

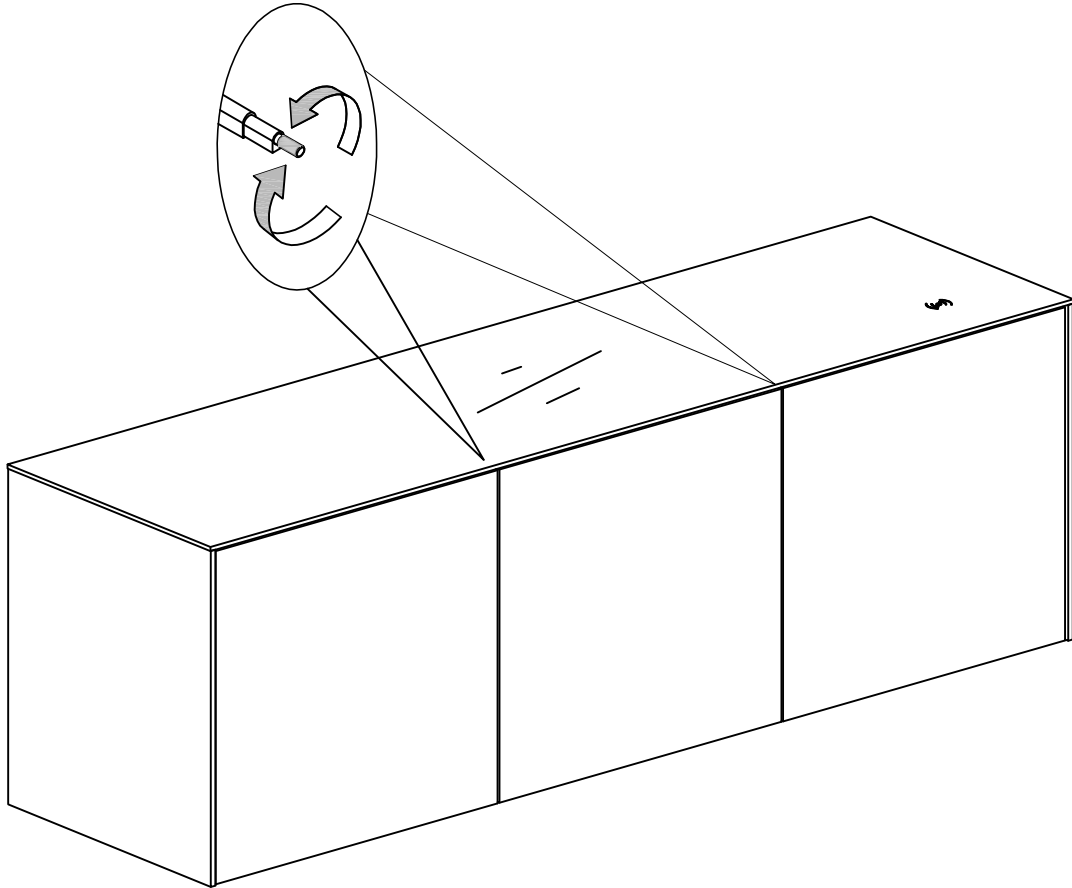

# 25

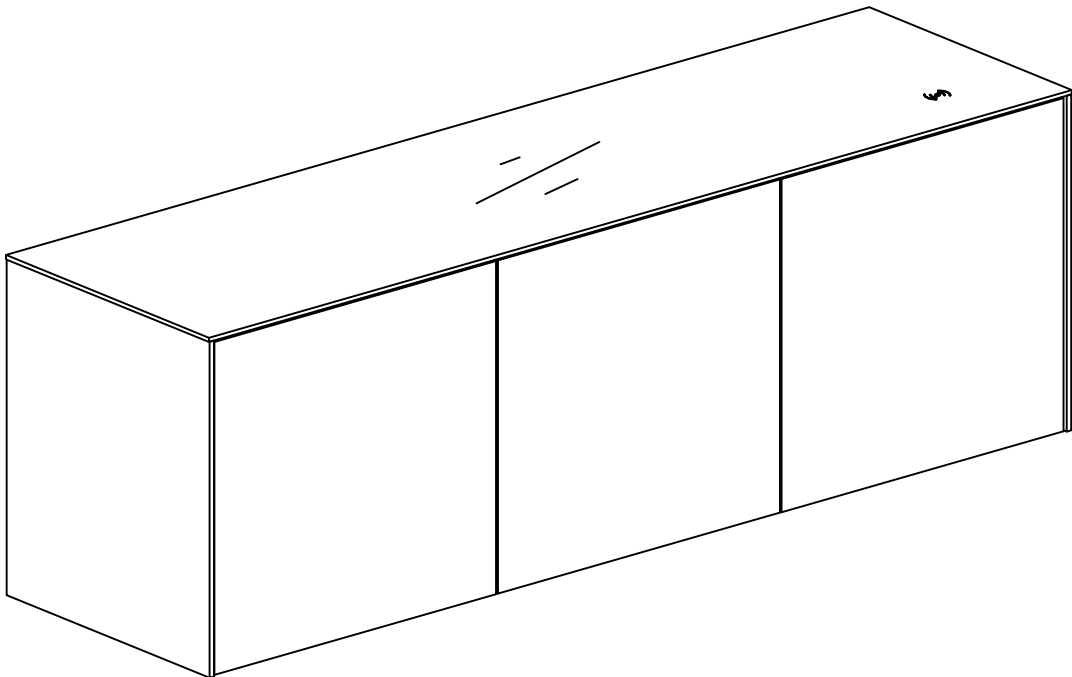

**CLEANING ADVICE:**

To avoid scratching the painted and glass surfaces, clean only with a non abrasive cleaner.

## **NOTES ON SETTING UP WIFI**

The LEDS lights only work on 2.4 GHz, they will not work on 5.0 GHz

Most homes are 2.4 GHz or operate a dual function. If for any reason the LED lights are not connecting to the app or Alexa, please check the router setting. Most routers will operate both 2.4 and 5.00 GHz so there should be no problem.

In commercial premises, there maybe software to block access connection to unknown apps or services. If this happens, please check with IT Department.

The system will work from a mobile WiFi hotspot from one phone to another. We recommend this approach if there are access issues.

## Using the wireless charging

The wireless charging will only work with Qi enabled wireless charging phones. Please check the phone is wireless charging compatible.

Note: We recommend removing the phone case during the charging process

- Using the 2amp / 12V plug provided, connect the wireless charger cable to the plug and connect to the power source.
- To charge your phone, simply place the phone on the charging position indicator and the phone will start to charge.
- To check if the charger is working, simply move the phone and if the lights under the glass are on, this indicates that the charger is working. You may need to reposition the phone slightly if the red / blue light is not showing.
- For the charger to work properly, the charging position within the back of the phone needs to sit aligned with the central red light.
- An element of heat is created during the wireless charging process, this is perfectly normal and safe.. The charger has a built in temperature control and will not over heat.
- If a phone has a thick case, it may affect the wireless charging, to resolve this remove the phone case during charging.
- If a phone case is used and charging process seems to stop and start, remove the phone case and try again, this should work better in this case.

**NOTE :** there may be a few second delay for the phone to register as charging which is normal.

### PHONE CHARGING SPOT ON FURNITURE

Note: The furniture comes with an easy peel removable sticker to indicate the charging position. Once removed, if you look closely, a charging position graphic is printed faintly in the glass. This is to help identify where to place the phone, but the idea is that it isn't really visible and so doesn't ruin the design of the cabinets.

For a guidance and help and contact details, please visit our website :  
[www.frankolsenfurniture.co.uk](http://www.frankolsenfurniture.co.uk)



Help in setting up doors  
- quick video link



Help in setting up the IR remote  
control manager - Quick video link



Help with the wireless charging  
Quick video link



LED lights and APP quick video

Simply hold the camera on a smartphone over the QR code above to go to  
a quick link to the help video