

INSTRUCTION

Libro de instrucciones

INSTRUCTION

Istruzioni per l'installazione

ANWEISUNG

사용설명서 取扱説明書



- *Two people for assembly
- *Instalieren zwei Personen zusammen
- *2人作業が必要です
- *Deux personnes pour l'assemblage
- *조립을 위해 두 사람 필요
- *Due persone per il montaggio
- *Dos personas para el montaje

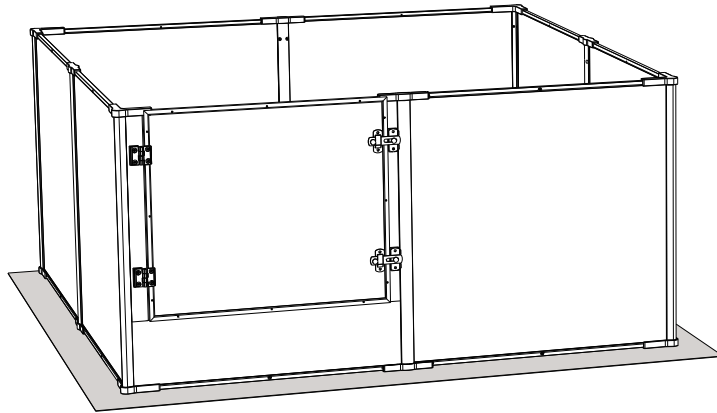

Product Name: Transparent fertility fence
XPETSYL-12S

Manufacturer: Yingbo Luo

Address:Tangkengwei Tanguang Village,Tangnan Town,
Fengshun County,Meizhou, Guangdong 514300

REPÚBLICA POPULAR DE CHINA

Country of origin:Made in China

Email:BingoPaw@wisfor.com

Warning:

When installing the product, it is best to wear gloves

Tragen Sie bei der Installation des Produkts am besten Handschuhe

組み立てる際、手袋を着用してください。

Lors de l'installation du produit, il est préférable de porter des gants

제품을 설치할 때 장갑을 착용하세요.

Durante l'installazione del prodotto, è meglio indossare guanti

Al instalar el producto, es recomendable usar guantes.

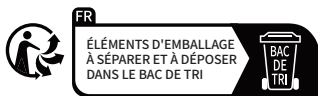

FR
Ce meuble se recycle,
s'il n'est plus utilisable,
déposez-le en déchèterie.
Notice à trier.
Pour en savoir plus:
www.quefairedemesdechets.fr



EU09173327553428rNW
We simply act as an EU representative for cross-border sellers, and are not manufacturers/import-ers/
distributors for the product, nor involved in the manufacturing/import-sale of the product. Therefore, we
are not responsible for any after-sales services related to the product. In case of any product quality or
infringement issues, the manufacturer/importers/seller shall be solely held responsible.



Company:YH Consulting Limited
Address: C/O YH Consulting Limited Office 147,
Centurion House, London Road,
Staines-upon-Thames, Surrey, TW18 4AX

A×3

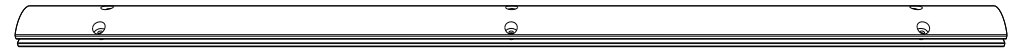

B×3



C×7

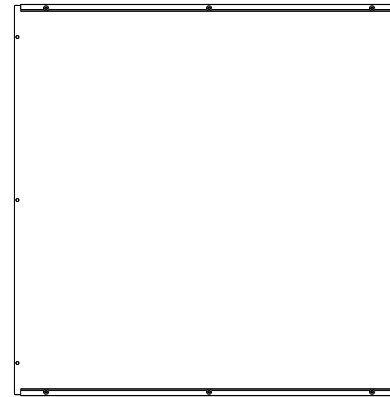

D×1

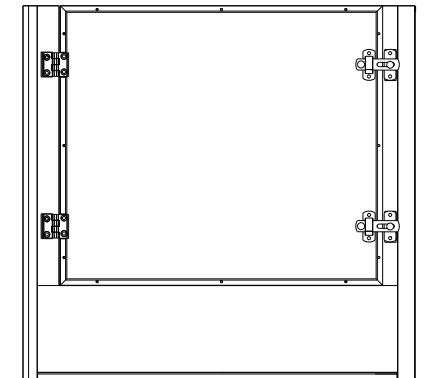

E×8

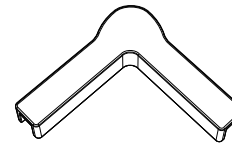

F×8

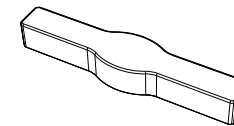

G×42

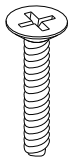

H×4

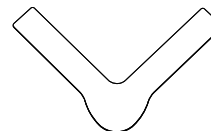

I×4



J×1



K×1

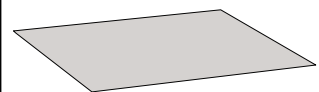

1. It is recommended that two people install it to save more time.

1. Es wird empfohlen, dass zwei Personen die Installation durchführen, um Zeit zu sparen.

1. Il est recommandé de procéder à l'installation à deux personnes, ce qui permettra de gagner du temps.

1. Si raccomanda di installare il prodotto in due persone, in modo da risparmiare tempo.

1. Se sugiere que dos personas realicen la instalación para ahorrar tiempo.

1. 重いものなので、二人で組立工事を行った方がおすすめです。

1. 무거운 것이기 때문에 3사람 같이 조립하는 것을 추천합니다.

2. Note: When fixing the screws to the corner posts, keep the screwdriver handle perpendicular to the board.

2. Hinweis: Halten Sie den Griff des Schraubendrehers beim Anbringen der Schrauben für die Eckpfosten senkrecht zur Platte.

2. Nota: quando si installano le viti per i montanti d'angolo, mantenere l'impugnatura del cacciavite in posizione verticale rispetto al pannello.

2. Remarque: Lors de l'installation des vis pour les poteaux d'angle, gardez le manche du tournevis perpendiculaire à la planche.

2. Al instalar tornillos para postes esquineros, mantenga el mango del destornillador perpendicular al tablero.

2.ご注意:スムーズに操作するため、ネジを回すとき、ドライバーのハンドルをボードに対して垂直に保ってください。

2. 주의: L형 기둥의 나사를 설치 시 드라이버는 판에 수직을 유지하면서 조립하십시오.

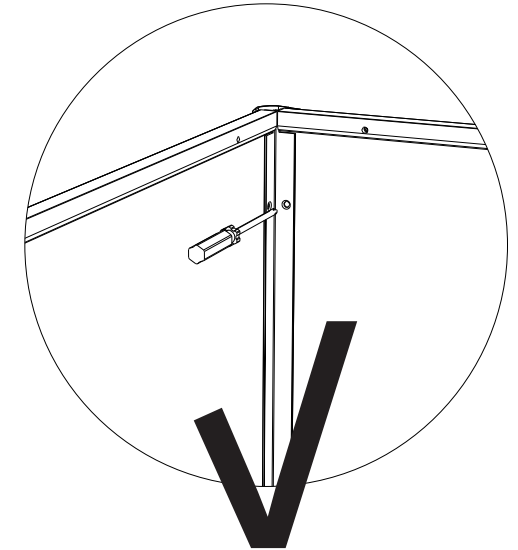
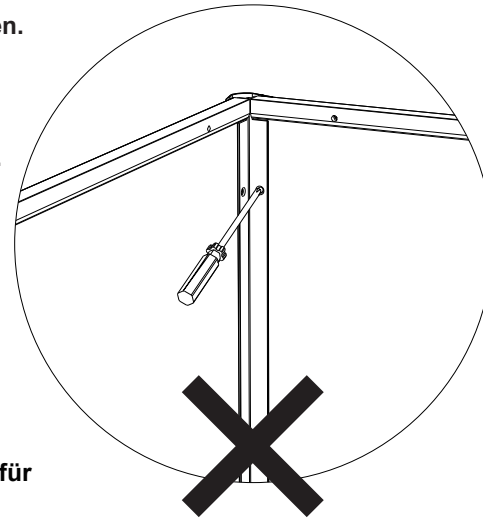

①

G*18

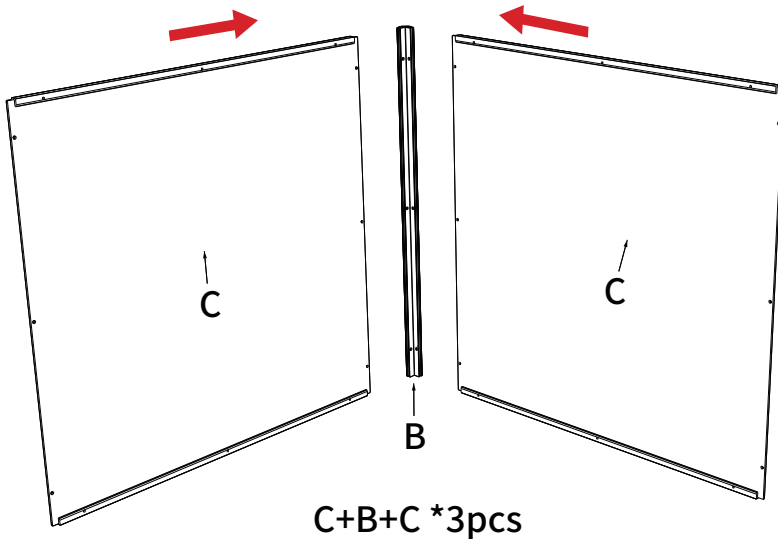

②

G*3

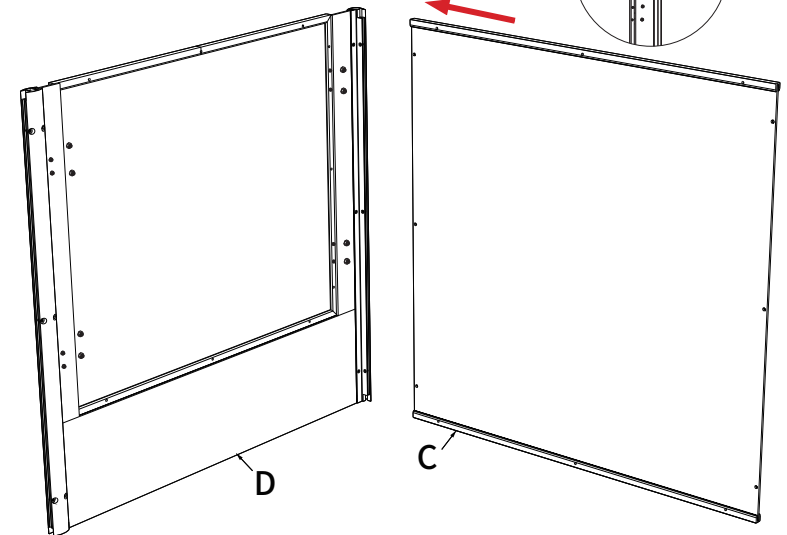

③

 G*21



*Two people for assembly
*Instalieren zwei Personen zusammen
*2人作業が必要です
*Deux personnes pour l'assemblage
*조립을 위해 두 사람 필요
*Due persone per il montaggio
*Dos personas para el montaje

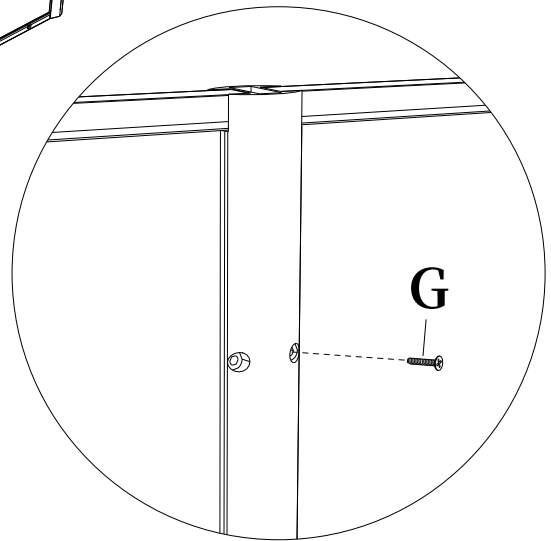
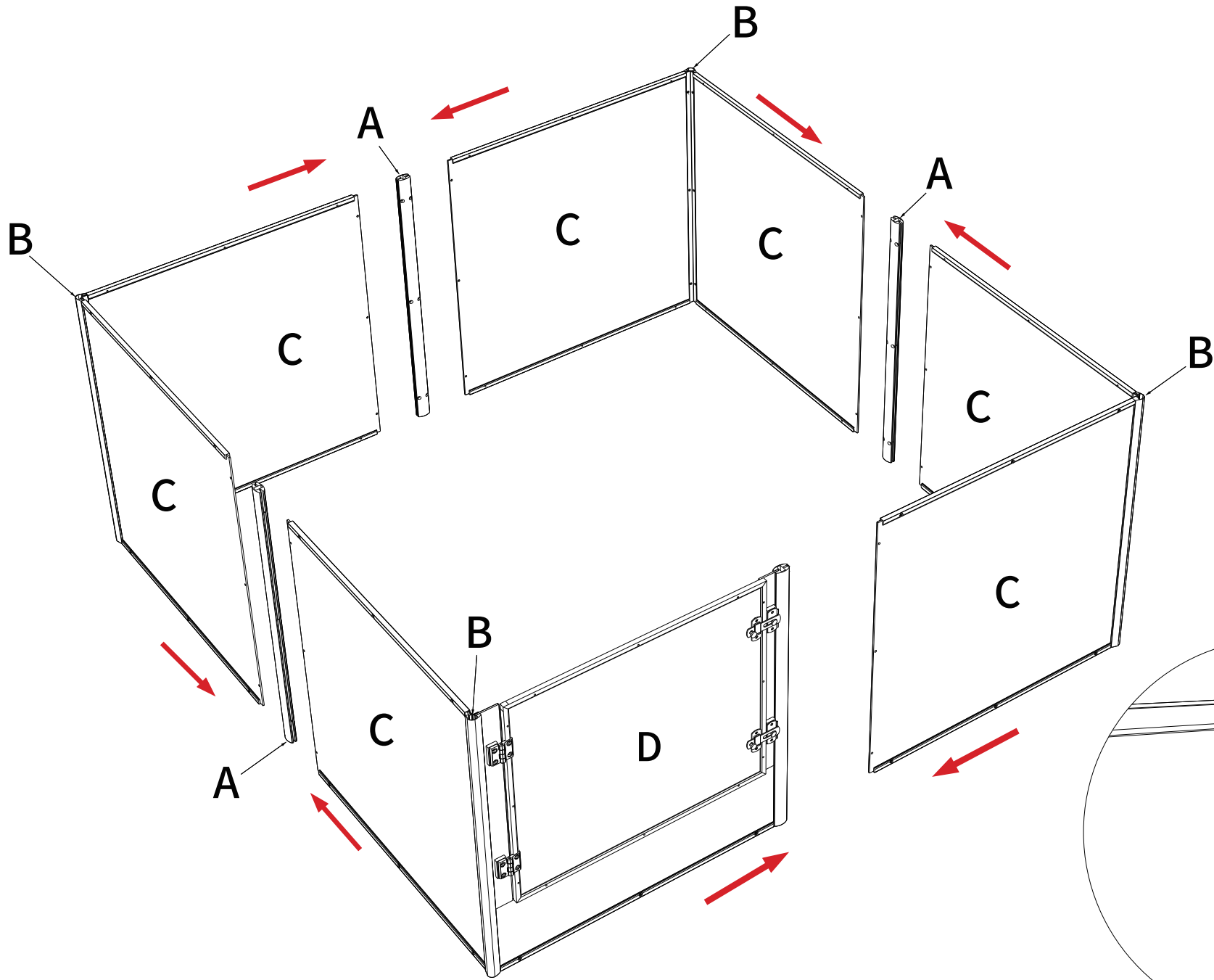

4

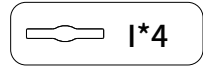
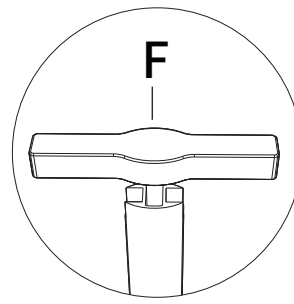
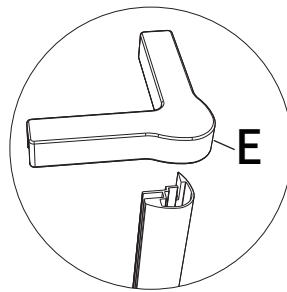
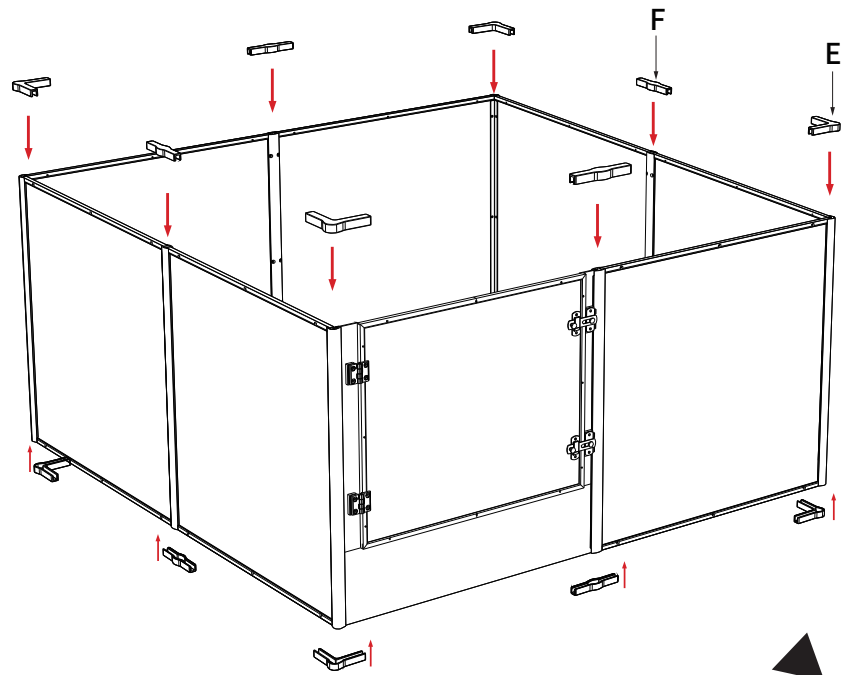

*Two people for assembly
 *Installieren zwei Personen zusammen
 *2人作業が必要です
 *Deux personnes pour l'assemblage
 *조립을 위해 두 사람 필요
 *Due persone per il montaggio
 *Dos personas para el montaje

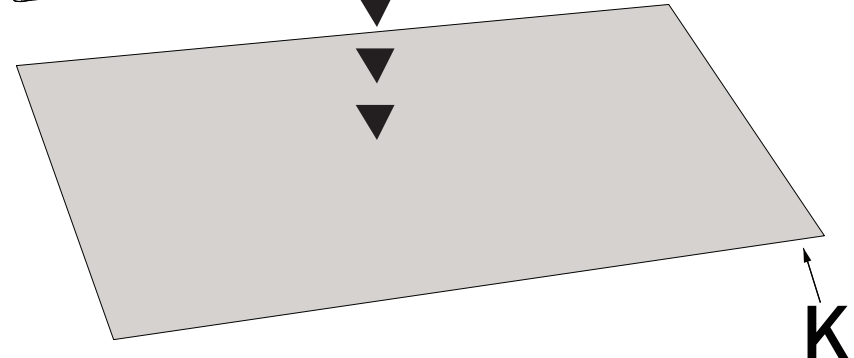
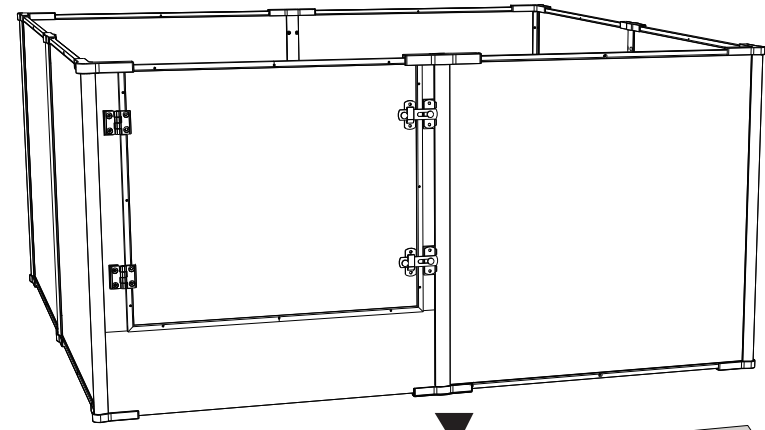
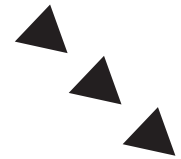
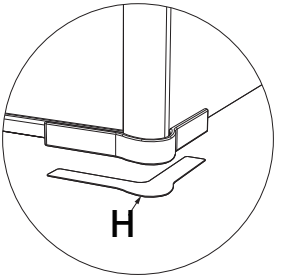
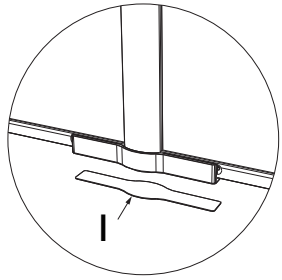

K