

INSTRUCTIONS
INSTRUCTION
ANWEISUNG

사용설명서
取扱説明書
ISTRUZIONI PER L'INSTALLAZIONE
LIBRO DE INSTRUCCIONES

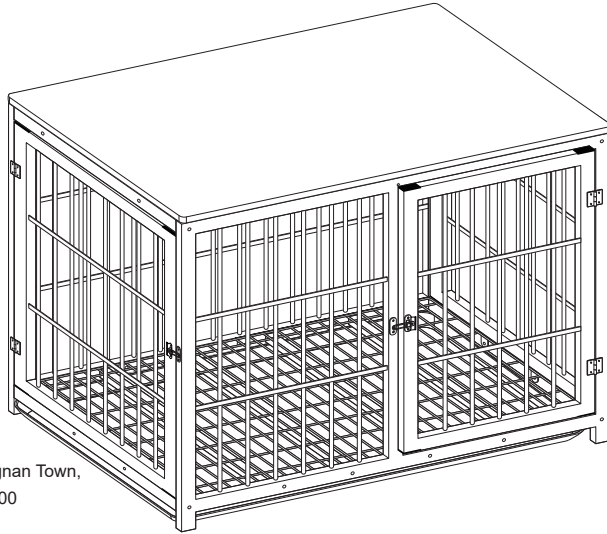

*Two people for assembly
*Instalieren zwei Personen zusammen
*2人作業が必要です
*Deux personnes pour l'assemblage
*조립을 위해 두 사람 필요
*Due persone per il montaggio
*Dos personas para el montaje



Product Name:Iron wood dog cage
P-XL171-XL-WT-V2 P-XL171-XL-BK-V2
Manufacturer: Yingbo Luo
Address:Tangkengwei Tanguang Village,Tangnan Town,
Fengshun County,Meizhou, Guangdong 514300
REPÚBLICA POPULAR DE CHINA
Country of origin:Made in China
Email:BingoPaw@wisfor.com

Warning:
Please install according to the instructions
Bitte gemäß den Anweisungen installieren
Veuillez installer selon les notices
Installare secondo le istruzioni
Seguir las instrucciones del manual para la instalación del producto
説明書に従って取り付けてください
설명서에 따라 설치하세요.

EC REP eVatmaster Consulting GmbH
Raiffeisen Street2B11,63110 Rodgau,
Hessen,Germany
contact@evatmaster.com

EU001733275535428rdNW
We simply act as an EU representative for cross-border sellers, and are not
manufacturers/import-ers/distributors for the product, nor involved in the
manufacture/import/sale of the product. There-fore, we are not responsible for any
after-sales services related to the product. In case of any product quality orinfringement
issues, the manufacturer/importer/seller shall be solely held responsible.

UK REP

Company:YH Consulting Limited
Address: C/O YH Consulting Limited Office 147,
Centurion House , London Road ,
Staines-upon-Thames , Surrey , TW18 4AX

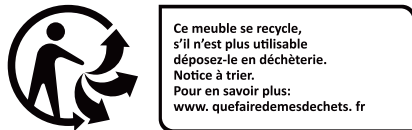
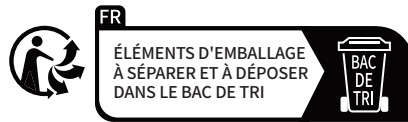

A*1

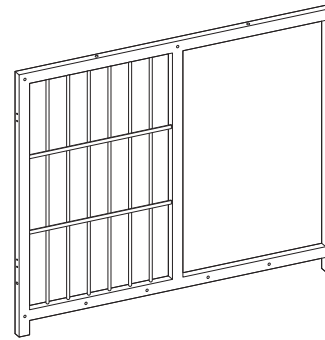

B*1

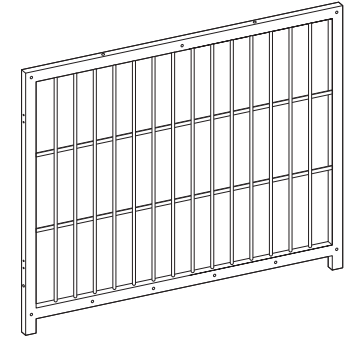

C*2

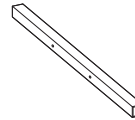

D*5

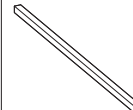

E1*1

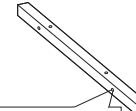

Without thread
Ohne Gewinde
ねじ山無しの穴
sans filetage
구멍
Senza filettatura
Sin rosca

E2*1

With thread
Mit Gewinde
ねじ山付きの穴
avec noix
너트 포함
Con filettatura
Con rosca

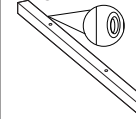

F*1

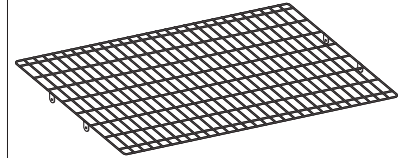

G*1

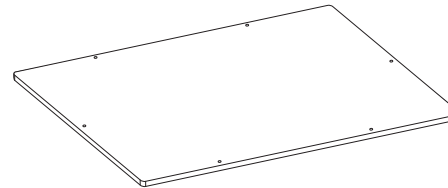

H*2

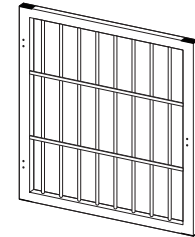

J*1



K*1

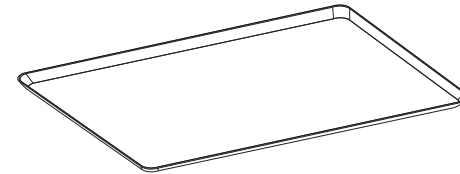

L1*1



M*3



L2*2



N*6



P*36



M5*15mm

Q*30



M6*38mm

R*4



M6

S*4

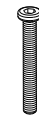

M6 *45mm

T*1

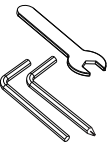

1

With arrows facing outward
Mit Pfeilen nach außen gerichtet
外へ
Avec la flèche tournée vers l'extérieur
화살표 밖으로 향함
Freccia verso l'esterno
Flecha hacia el exterior

Concave hole facing downward
Konkaves Loch nach unten gerichtet
角パイプのネジ穴が凹んでいる片側を下へ向けてください
Trou concave orienté vers le bas
나사 구멍은 오목한 면이 아래로 향하게 되십시오.
Foro concavo verso il basso
Agujero cóncavo hacia abajo

Q*8



M6 *38mm

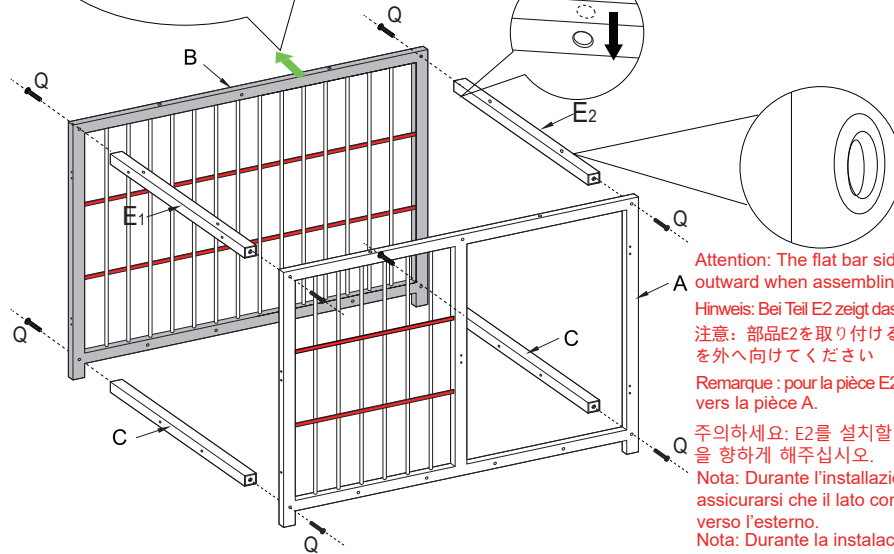

Attention: The flat bar side with screw thread facing outward when assembling the E2 parts

Hinweis: Bei Teil E2 zeigt das Loch für die Mutter zu Teil A.
注意: 部品E2を取り付けるとき、ねじ山付きの穴の片側を外へ向けてください

Remarque: pour la pièce E2, le trou pour l'écrou est dirigé vers la pièce A.

주의하세요: E2를 설치할 때 너트 달린 구멍은 바깥쪽을 향하게 해주십시오.

Nota: Durante l'installazione del componente E2, assicurarsi che il lato con il foro della vite sia rivolto verso l'esterno.

Nota: Durante la instalación del componente E2, asegúrese de que el lado con el agujero del tornillo esté orientado hacia el exterior.

!!! Note: When assembling, the horizontal flat bar of part A and B should be facing outward
Hinweis: Achten Sie beim Zusammenbau darauf, dass die Querstreben der Teile A und B nach außen zeigen.

注意: 組み立てる時、部品Aも部品Bも横バーのあった片側が外へ向いていることを確認してください。

Remarque: Lors de l'assemblage, assurez-vous que le côté barre horizontale des pièces A et B est dirigé vers l'extérieur.

주의: 조립시, 부품A와 B에 있는 가로 막대기는 밖으로 향하게 하고

Suggerimento: Durante l'assemblaggio, i montanti dei componenti A e B devono essere rivolti verso l'esterno.

Sugerencia: Durante el ensamblaje, los montantes de los componentes A y B deben estar orientados hacia el exterior.

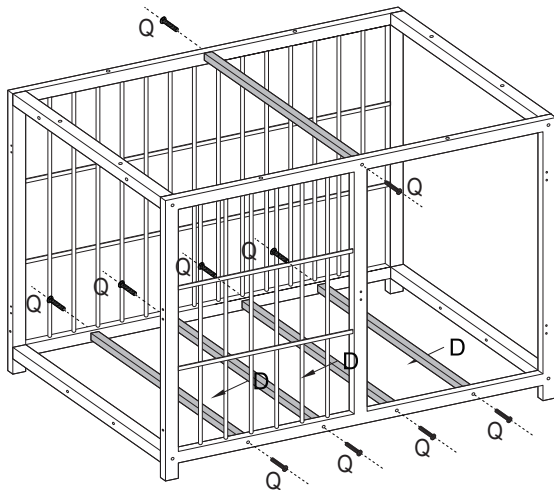

Q*10



M6 *38mm

2

Q*4



M6 *38mm

R*4



M6

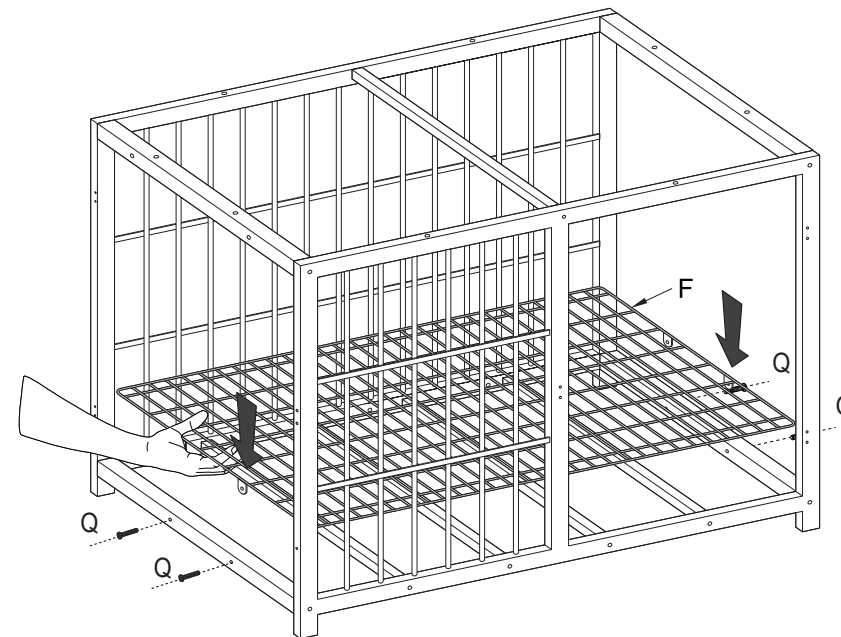
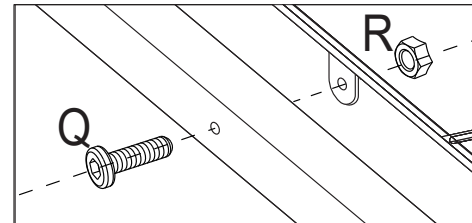

3

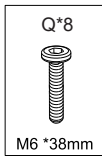
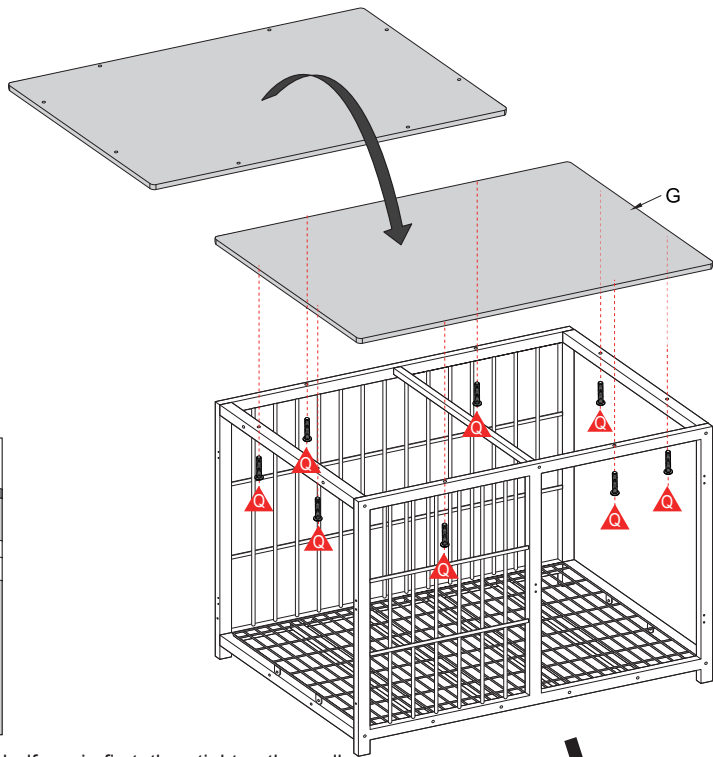

3. Turn all the screws halfway in first, then tighten them all.

3. Schrauben Sie zuerst die Hälfte der Schrauben ein und verriegeln Sie sie dann, nachdem alle Schrauben eingeschraubt sind.

3. 組立の豆知識: 全てのネジをゆるゆるの状態に仮止めしてから、締めていけば、上手に組み立てできます。

3. Commencez par visser la vis à moitié, puis serrez toutes les vis avant de verrouiller la vis.

3. 모든 나사를 느슨한 상태에서 임시 고정한 후 조이면 잘 조립할 수 있습니다.

3. Avvitare prima le viti a metà, poi, una volta inserite tutte le viti, serrarle completamente.

3. Atornille primero los tornillos a la mitad, luego, una vez insertados todos los tornillos, apriételes completamente.

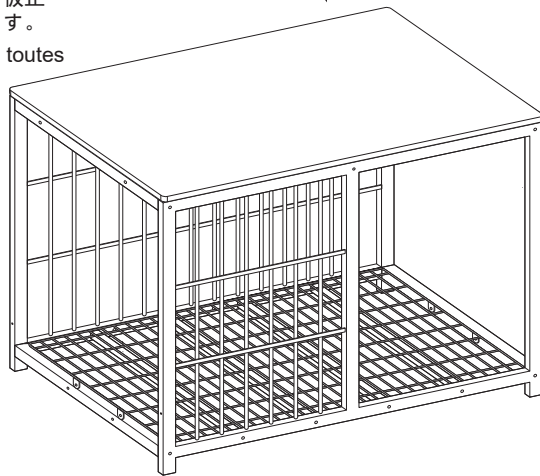

4

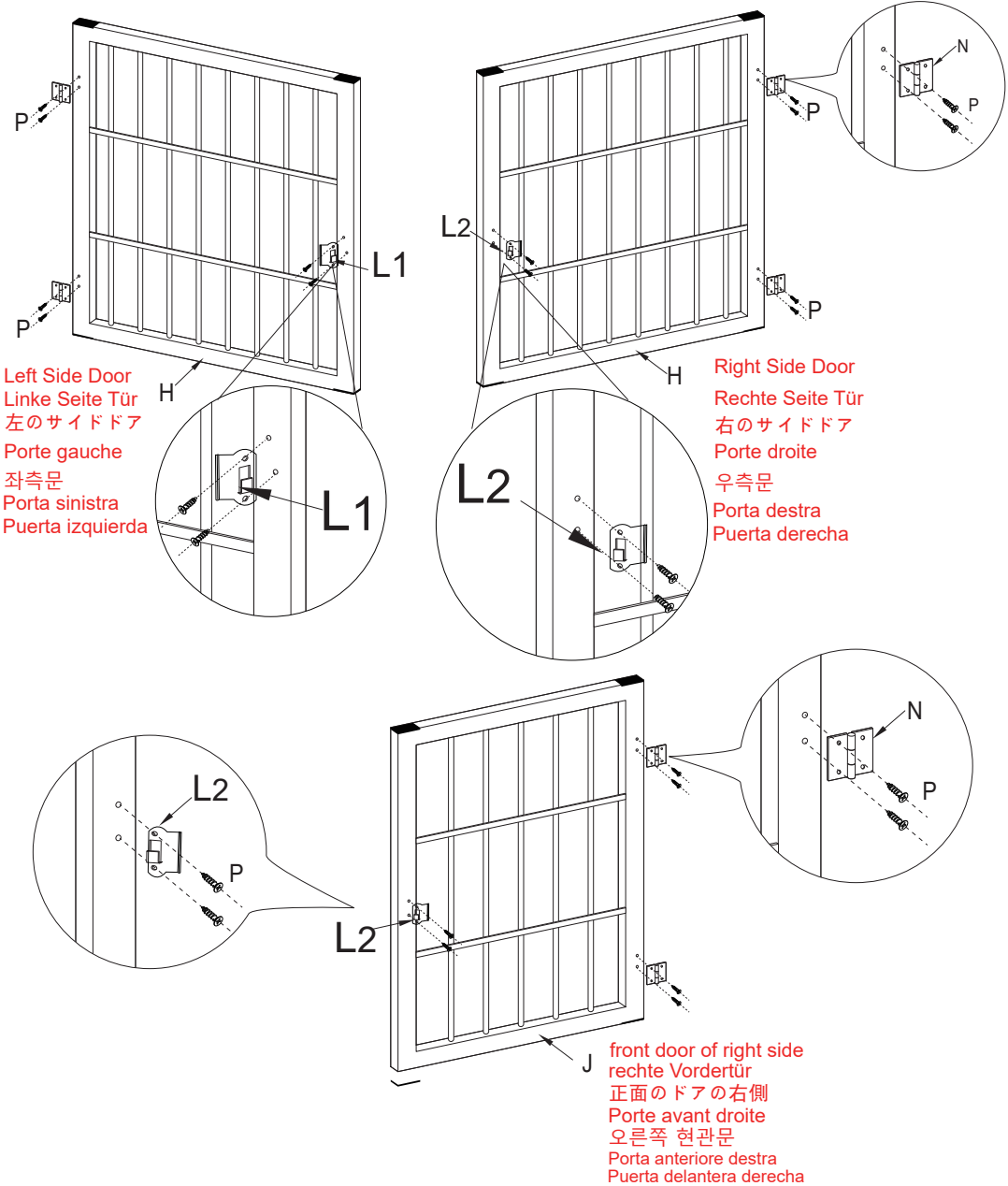
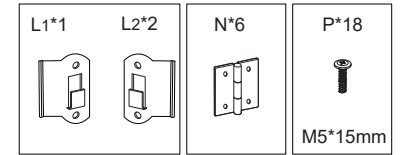

Left Side Door
Linke Seite Tür
左のサイドドア
Porte gauche
좌측문
Porta sinistra
Puerta izquierda

Right Side Door
Rechte Seite Tür
右のサイドドア
Porte droite
우측문
Porta destra
Puerta derecha

front door of right side
rechte Vordertür
正面のドアの右側
Porte avant droite
오른쪽 현관문
Porta anteriore destra
Puerta delantera derecha

5

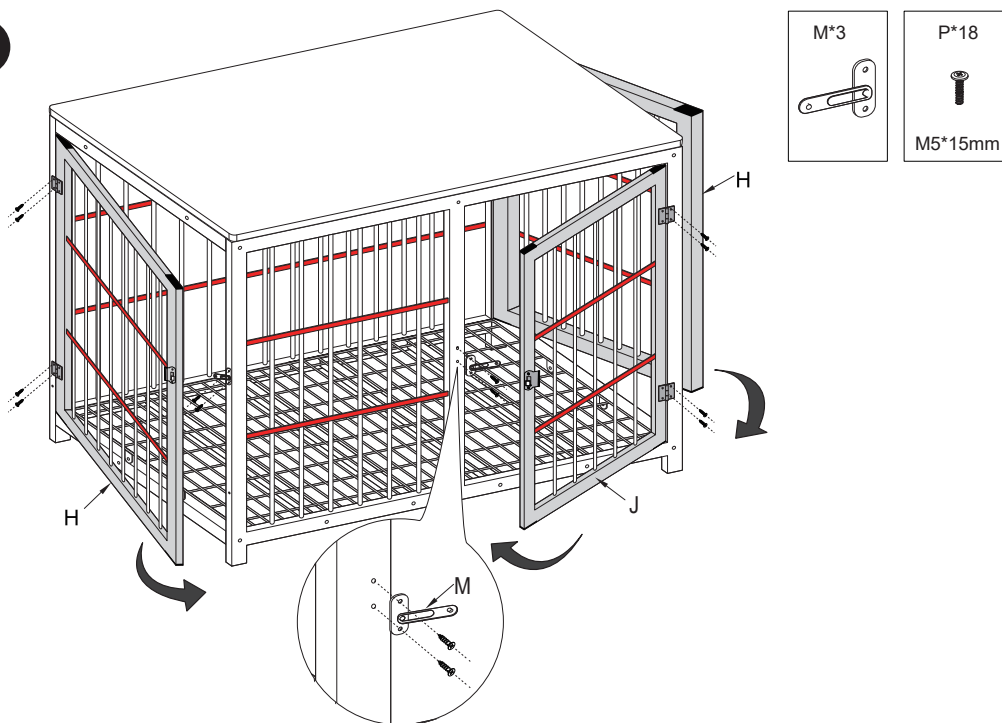

!!! Note: When assembling, the horizontal flat bar of part H and J should be facing outward
 Hinweis: Achten Sie beim Zusammenbau darauf, dass die Querstreben der Teile H und J nach außen zeigen.

注意: 組み立てる時、部品Hも部品Jも横バーのあった片面が外へ向いていることを確保

Remarque: Lors de l'assemblage, assurez-vous que le côté barre horizontale des pièces H et J est dirigé vers l'extérieur.

주의: 조립시, 부품H와 J에 있는 가로 막대기는 밖으로 향하게 하고

Suggerimento: Durante l'assemblaggio, i montanti dei componenti H e J devono essere rivolti verso l'esterno.

Sugerencia: Durante el ensamblaje, los montantes de los componentes H y J deben estar orientados hacia el exterior.

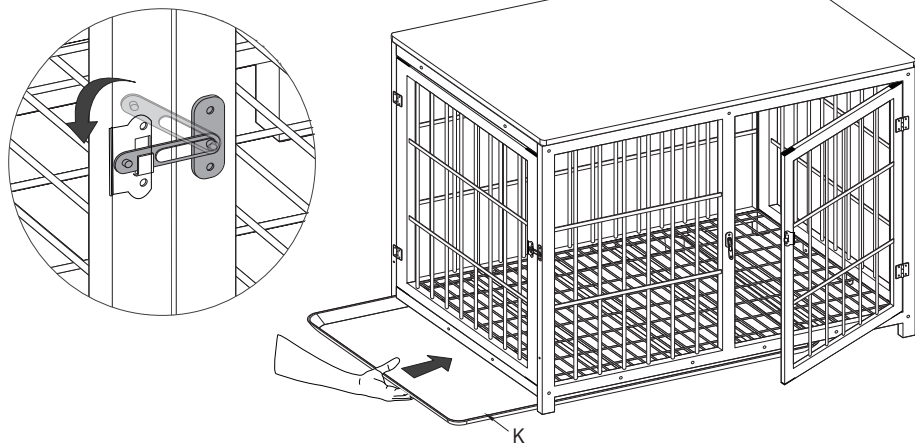

6



*Two people for assembly
 *Instalieren zwei Personen zusammen
 *2人作業が必要です
 *Deux personnes pour l'assemblage
 *조립을 위해 두 사람 필요
 *Due persone per il montaggio
 *Dos personas para el montaje



Uses when two dog cages combined
 Verwendet, wenn zwei Hundekäfige kombiniert werden
 連結用
 S'utiliser lorsque deux cages pour chiens sont combinées
 連結용
 Utilizzare quando due gabbie per cani sono unite.
 Utilizar cuando dos jaulas para perros están unidas.

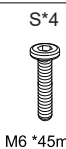

M6 *45mm

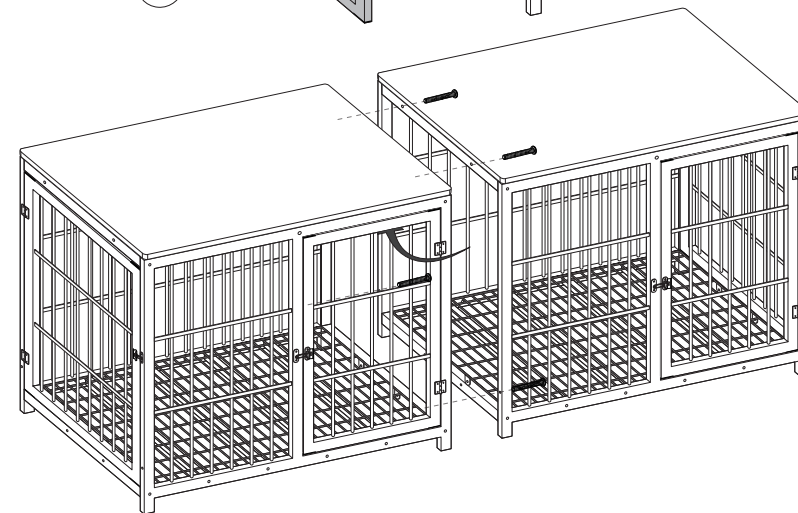
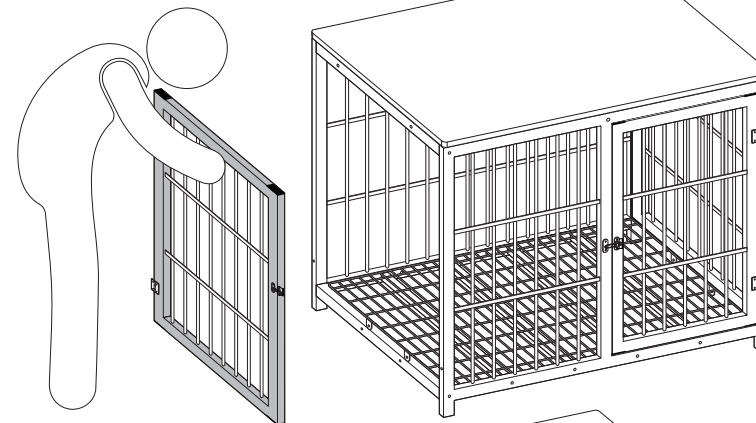

6.no need to assembled the side doors, just using screws S to joint together if you purchase two dog cages.

6.Wenn Sie möchten, dass zwei Käfige kombiniert werden, anstatt die Seitentüren zu installieren, verwenden Sie zum Kombinieren S-Schrauben.

6.もし2つのケージを合わせて使いたい場合には、側板を外してからネジ-Sで繋いでください。

6.Si vous souhaitez combiner deux cages au lieu d'installer les portes latérales, utilisez des boulons en S pour combiner.

6.제품 두 개를 구매하시면 양쪽 사이드 도어를 설치할 필요 없이 나사 S로 연결하시면 됩니다.

6.Se hai acquistato due gabbie per cani, non è necessario assemblare la porta laterale, basta collegarle insieme con le viti S.

6.Si ha comprado dos jaulas para perros, no es necesario ensamblar la puerta lateral, simplemente conéctelas juntas con los tornillos S.