

# Installation Instructions: Fire Exit push Pad or Push Bar (internal) with Blank External

1



Use the spindle to align the template to the inside of the door.  
(This will be removed later before installation of the hardware as is not required for a blank external door.)

Ensure level and square, & apply masking tape to secure.

Locate the 2 x 1mm pilot holes on the bottom section of the template (shown in red).  
Drill with 8mm bit.

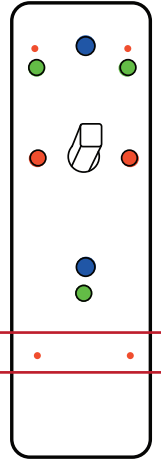

2

Once drilled, remove the spindle & sashlock from the door.  
These are not required for this type of door installation.

Replace with the opening on the end of the door with a cover plate with the 2 screws as shown.

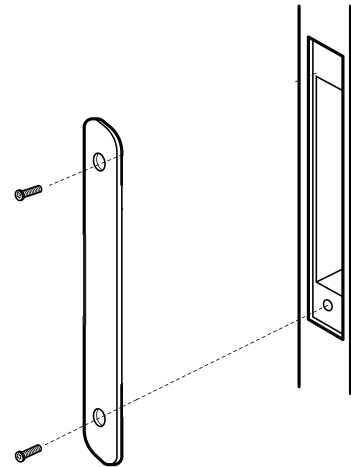

3

Attach the sleeves to the rear of the blanking plate & tighten by hand (be careful not to overtighten as this can damage the blanking plate)

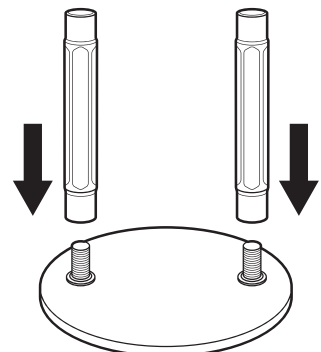

# Installation Instructions: Fire Exit push Pad or Push Bar (internal) with Blank External

**4**

Align & Insert into the door pre-drilled holes from the outside of the door. Repeat for both top and/or bottom holes.

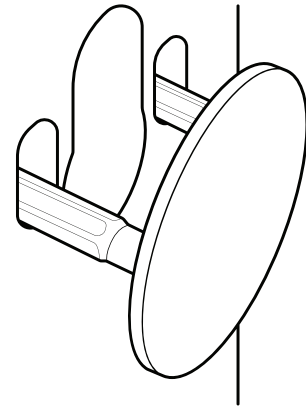
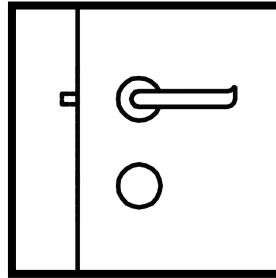

**5**

Fix the top blank in place with qty 2 of x 5mm x 35mm machine screws supplied to through the template by hand (ENSURE metal template remains in position internally & is secured by screws).

DO NOT screw the lower blank at this stage.

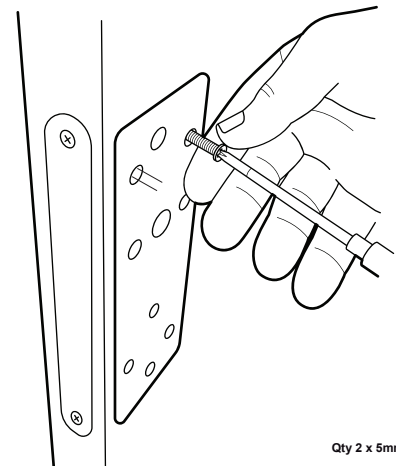

Qty 2 x 5mm x 35mm

**6**

SET THE HANDING

1. Remove follower
2. Swap latchbolt to opposite site of case
3. Re-fit Latchbolt Spring over stud marked 'L' or 'R'

SEE BRITON INSTRUCTIONS FOR FULL DETAILS ON SWAPPING THE ORIENTATION

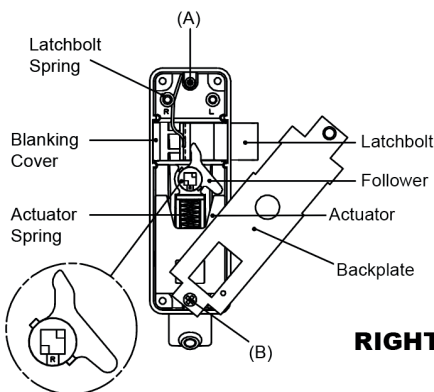

**RIGHT HAND**

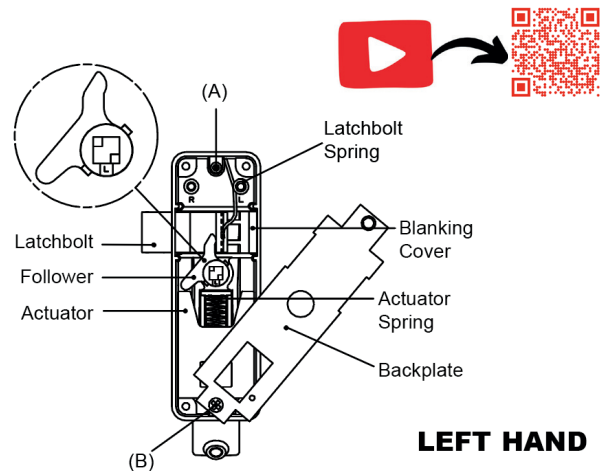

**LEFT HAND**

# Installation Instructions: Fire Exit push Pad or Push Bar (internal) with Blank External

7

Once satisfied, secure the bottom 2 holes, use 2 of the 5mm x 49 screws provided to screw through the push pad/bar into the back of the lower door blank from step 4.

Then, use 2 of the 4mm x 45mm self drilling screws to secure the push pad into position using the top holes.  
Note, Do not over tighten.

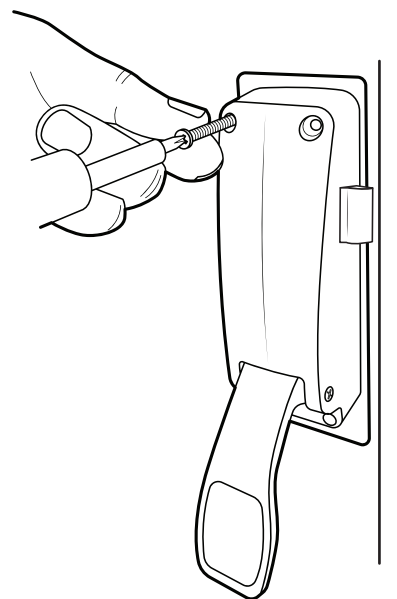

8

OPTIONAL: If using a Push Bar instead, the push bar will need to be cut to suit the door leaf width (42mm smaller than door leaf).

Once cut, level & mark the 2nd lever ensuring minimum 15mm gap from to the door frame. Ensuring level, fix the 2nd lever in position using 4 x 45mm self drilling screws.

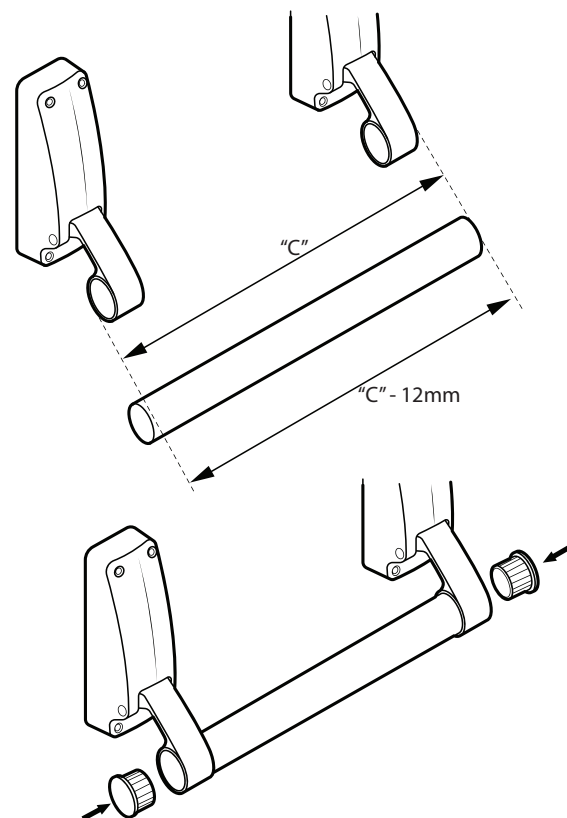

# Installation Instructions: Fire Exit push Pad or Push Bar (internal) with Blank External

9

Close the door 2 and mark where the latchplate meets the frame with a pencil.

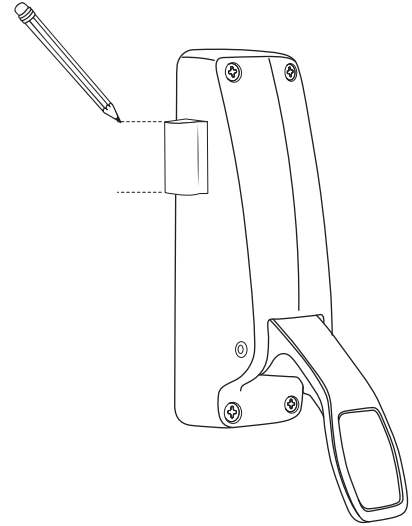

10

Cut out the centred black section from the A4 template page, fold along the dashed line & place it over the pencil marks from step 9 along the edge of the framing, making note of the gasket location.

Facefix the strikeframe into position by with self drilling screws in the marked hole position on the template.

NOTE - ensure the flat face of the strikeframe with the bevelled strike us facing outwards to enable the door to latch. Holes can be counter-sunk with a drill bit if required.

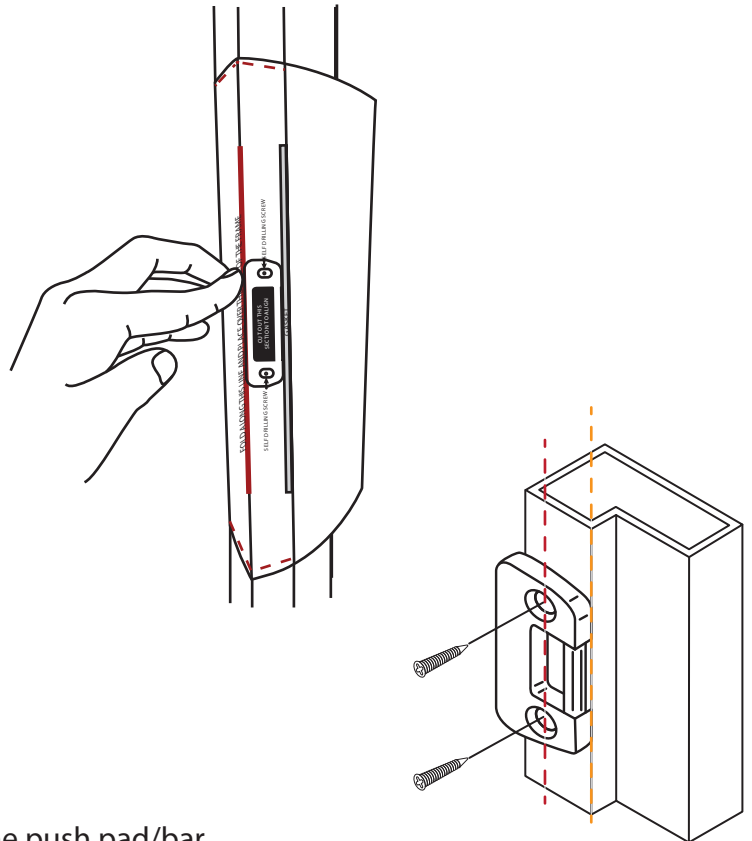

Test several times by closing and fully engaging the push pad/bar to release. Apply vinyl signage as necessary (sold separately).

**TEMPLATE COVER PLATE FOR INSTALLATION OF FIRE EXIT PUSH PAD / OUTSIDE ACCESS DEVICE / EXTERNAL BLANKING PLATES**

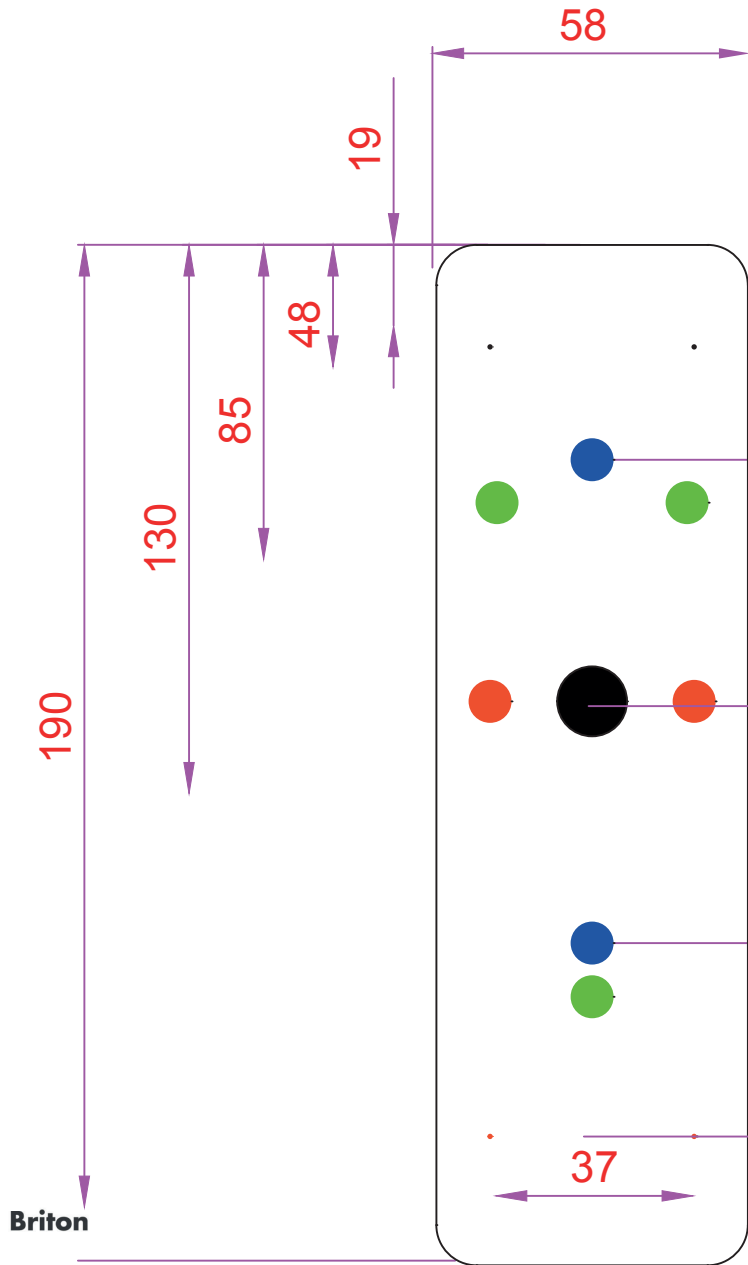

1MM GUIDE HOLE FOR SELF DRILLING SCREWS (ONLY IF OUTSIDE ACCESS DEVICE IS FITTED)

8MM HOLE TO SECURE BRITON1413 OUTSIDE ACCESS DEVICE (requires drilling of door with 8mm drill bit)

8MM HOLE TO FOR HANDLE/ESCUTCHEON OR EXTERNAL DOOR BLANK

8MM HOLE TO SECURE BRITON1413 OUTSIDE ACCESS DEVICE (requires drilling of door with 8mm drill bit)

1MM GUIDE HOLE FOR SELF DRILLING SCREWS (ONLY IF OUTSIDE ACCESS DEVICE IS FITTED)

OR

DRILL TO MAKE 8MM HOLE IF FITTING AN EXTERNAL BLANK



Optional External Outside Access Device - Lockable

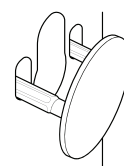

# Steel Security Door – Operations & Maintenance Manual

The door assemblies consist of various components, each presenting unique maintenance considerations. We recommend performing maintenance on the doors and associated hardware every two months. This schedule can be adjusted after the initial visit, based on actual usage.

Proper maintenance of all components is crucial; neglecting any part can lead to premature wear or malfunction. For example, a door blade may appear undamaged, but if the panic hardware is untested, it could pose a safety risk.

Please note that all doors come with a manufacturer's warranty (see terms and conditions for details). This warranty may be voided if maintenance is not performed as outlined in this manual.

## Door Maintenance

Inspect door alignment every 6 months to ensure the door and frame are true. Doors should be free of dents and scratches and should operate smoothly. Regularly check door seals for proper fit and signs of damage.

Ensure doorways are free from obstructions to allow unimpeded operation. Daily visual inspections should be conducted to promptly identify any damage. Report any issues to the designated responsible person for timely resolution.

Locks and panic hardware must be checked for proper operation, and adjustments made as necessary. For any malfunctioning ironmongery, please contact us for assistance.

## Latches & Hinges

Hinges should be installed accurately for optimal performance, with all hinge pins aligned vertically. Periodic inspections are necessary to check for wear that could hinder movement or cause the door to sag.

All screws should be tightened to prevent loosening, which is often caused by misalignment or improper screw choice. Loose screws should be addressed, either through tightening, realignment, or by using more suitable screws.

Lubricate hinges with light machine oil periodically. Squeaking indicates a need for lubrication, but frequent squeaks may suggest misalignment issues. For stainless steel hinges, dust regularly, wash with warm soapy water, and avoid abrasive cleaners. A light grease coating is recommended post-cleaning.

Correctly fitted locks and latches may still malfunction due to door or frame movement caused by environmental factors. Adjust the latch and deadbolt positioning if needed.

Regularly check for debris in the mortise and ensure that frame holes behind striking plates are clear to facilitate smooth bolt movement. Lubricate latch bolts, avoiding grease on internal mechanisms to prevent dust attraction.

### Cylinders

Avoid oil lubricants on cylinders, as they attract dust. Use powdered graphite periodically for maintenance.

### Lever Handles

Check backplate and rose fixings for tightness. Poorly maintained hardware can impede lock function. Ensure spindle grub screws are secure.

### Pull Handles

Inspect pull handles for tight fixings. Loose handles can damage the door.

### Emergency and Panic Exit Hardware

Regular inspections are vital for safety. Ensure ease of operation and adjust for any door or frame movement. Keep floor sockets clean to allow free movement of bolts. Light machine oil can be applied to pivot points.

Outside access devices (OADs) on fire exit doors should only be used for limited access to maintain their functionality.

### Paintwork

Steel doors typically feature a powder coat or stainless steel finish. Clean as follows:

- General dirt: Use a non-abrasive cleaning solution diluted in hot water. Wipe with a wrung cloth to avoid soaking.
- Specific issues: Seek specialized advice for specific stains or problems.
- Surface damage: Touch up scratches with a compatible paint system

### Care of Finishes

Corrosion often results from dirt and moisture on metal surfaces. In harsh environments, acidic or alkaline deposits can deteriorate finishes. Proper maintenance is essential for longevity.

Regularly dust surfaces with a soft, dry cloth, and occasionally clean with warm soapy water. Follow up with a quality wax polish to protect finishes. Avoid chemical sprays, abrasive cleaners, and materials that could damage surfaces.

- Electro-Plated Finishes - Clean with soapy water and a soft cloth, then dry.
- Powder Coating and 2-Pack Paint Finishes - Use a soft cloth and household furniture polish for cleaning; avoid industrial solvents.

### Refinishing and On-Site Repairs

Remove all hardware before repainting. Never paint over hinges or locks. For minor dents, use car body filler and weatherproof paint.

# Installation Instructions: Fire Exit push Pad or Push Bar (internal) with Blank External

## FINAL CHECKS

Panic exit devices must be fitted to comply with the requirements of EN 1125 which states that the device should be easily operated by hand or body pressure in a panic situation. We suggest the following checks be made on all panic and emergency exit hardware:

- Check that the door has not become distorted in any way. If the door does not meet the frame stops and cannot be pulled in by the door closer the door may need to be replaced.
- Check that the door hinges are operating smoothly and lubricate if necessary.
- Check that the latches are operating freely. If necessary remove the end box covers and/or pullman latch covers and lubricate if necessary.
- Check that all fixings are tight.

## MONTHLY CHECKS

Inspect and operate the device to ensure all the components are in satisfactory working condition and operate as follows:

- a. After being pushed the 'Push bar' or 'Push Pad' should return automatically to its initial position.
- b. When pushed from the end casing side (hinge side of door) the latchbolt(s) should completely withdraw from their strikes as if it were pushed from the main casing side.

**IMMEDIATE EXIT MUST BE PERMITTED.**

- c. With the door closed, the latchbolts should be fully engaged into their strikers. They should not withdraw if pushed but should only withdraw if operated by the 'Push bar'.

Test several times by closing and fully engaging the push pad to release. Apply vinyl signage as necessary (sold separately).

# Installation Instructions: Fire Exit push Pad or Push Bar (internal) with Blank External

## STRIKEPLATE TEMPLATE

1. Cut out
2. Fold
3. 2 x Self-drilling screws

