

Cat House  
Maison pour Chat

**PV10053**

USA office: Fontana   AUS office: Truganina   GBR office: Ipswich   FRA office: Saint Vigor d'Ymonville

If you're having difficulty, our friendly customer team is always here to help.



USA:cs.us@costway.com  
AUS:cs.au@costway.com  
GBR:cs.uk@costway.com  
FRA:cs.fr@costway.com

THIS INSTRUCTION BOOKLET CONTAINS **IMPORTANT** SAFETY INFORMATION. PLEASE READ AND KEEP FOR FUTURE REFERENCE.

EN



### Before You Start

- ⚠ Please read all instructions carefully.
- ⚠ Retain instructions for future reference.
- ⚠ Separate and count all parts and hardware.
- ⚠ Read through each step carefully and follow the proper order.
- ⚠ We recommend that, where possible, all items are assembled near to the area in which they will be placed in use, to avoid moving the product unnecessarily once assembled.
- ⚠ Always place the product on a flat, steady and stable surface.
- ⚠ Keep all small parts and packaging materials for this product away from babies and children as they potentially pose a serious choking hazard.



FR







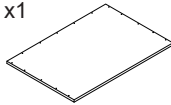
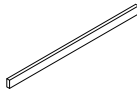
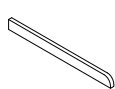
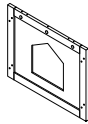
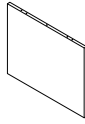
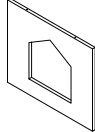
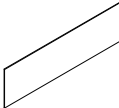
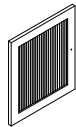
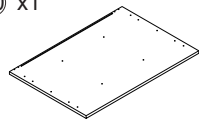
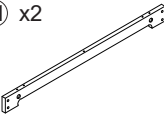
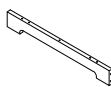
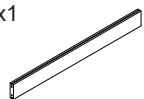



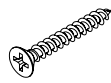

### Avant de Commencer

- ⚠ Veuillez lire attentivement toutes les instructions.
- ⚠ Conservez les instructions pour vous y référer ultérieurement.
- ⚠ Vérifiez toutes les pièces et les accessoires.
- ⚠ Lisez attentivement chaque étape et suivez l'ordre correct.
- ⚠ Nous recommandons que, dans la mesure du possible, tous les produits soient assemblés à proximité de la zone où ils seront utilisés, afin d'éviter tout déplacement inutile du produit une fois assemblé.
- ⚠ Placez toujours le produit sur une surface plane et stable.
- ⚠ Conservez toutes les petites pièces de ce produit et les matériaux d'emballage hors de portée des bébés et des enfants, car ils pourraient présenter un risque d'étouffement.

## Parts and Operation Elements / Liste des Pièces

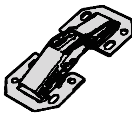
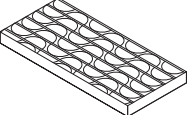
<p>① x1</p>  <p>Top Board / Panneau supérieur</p>	<p>② x1</p>  <p>Top Long Trim / Garniture longue supérieure</p>	<p>③ x2</p>  <p>Top Short Trim / Garniture courte supérieure</p>
<p>④ x1</p>  <p>Left/Right Side Board / Panneau latéral gauche/droit</p>	<p>⑤ x1</p>  <p>Left/Right Side Board / Panneau latéral gauche/droit</p>	<p>⑥ x1</p>  <p>Middle Vertical Board / Panneau vertical central</p>
<p>⑦ x2</p>  <p>Back Board / Panneau arrière</p>	<p>⑧ x2</p>  <p>Door / Porte</p>	<p>⑩ x1</p>  <p>Bottom Board / Panneau inférieur</p>
<p>⑪ x2</p>  <p>Bottom Long Support Board / Panneau de support long inférieur</p>	<p>⑫ x2</p>  <p>Bottom Short Support Board / Panneau de support court inférieur</p>	<p>⑬ x1</p>  <p>Back Horizontal Support Board / Panneau de support horizontal arrière</p>
<p>⑭ x1</p>  <p>Right Back Support Board / Panneau de support arrière droit</p>	<p>⑮ x1</p>  <p>Left Back Support Board / Panneau de support arrière gauche</p>	

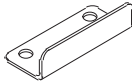
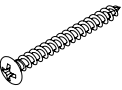
## Hardware / Liste des Accessoires

<p>(A) x24</p>  <p>Cam Bolt / Boulon à came</p>	<p>(B) x24</p>  <p>Cam Lock / Serrure à came</p>	<p>(C) x37</p>  <p>Dowel / Cheville</p>
<p>(D) x18</p>  <p>4x30 Screw / Vis 4x30</p>	<p>(E) x1</p>  <p>Dual Using Screw Driver / Tournevis à double utilisation</p>	<p>(F) x2</p>  <p>4x20mm bolt / Boulon 4x20mm</p>
<p>(G) x2</p>  <p>Handle / Poignée</p>	<p>(H) x24</p>  <p>Round Slicker For Cam Lock Hole / Autocollant rond pour trou de serrure à came</p>	<p>(I) x4</p>  <p>Hinge / Charnière</p>
<p>(J) x1</p>  <p>Cat Scratching Board / Planche à Gratter Pour Chat</p>	<p>(K) x32</p>  <p>3x14 Screw / Vis 3x14</p>	<p>(L) x1</p>  <p>Doorstop/Butée de porte</p>
<p>(M) x2</p>  <p>4x40 Screw / Vis 4x40</p>	<p>(N) x2</p>  <p>3x12 Screw / Vis 3x12</p>	

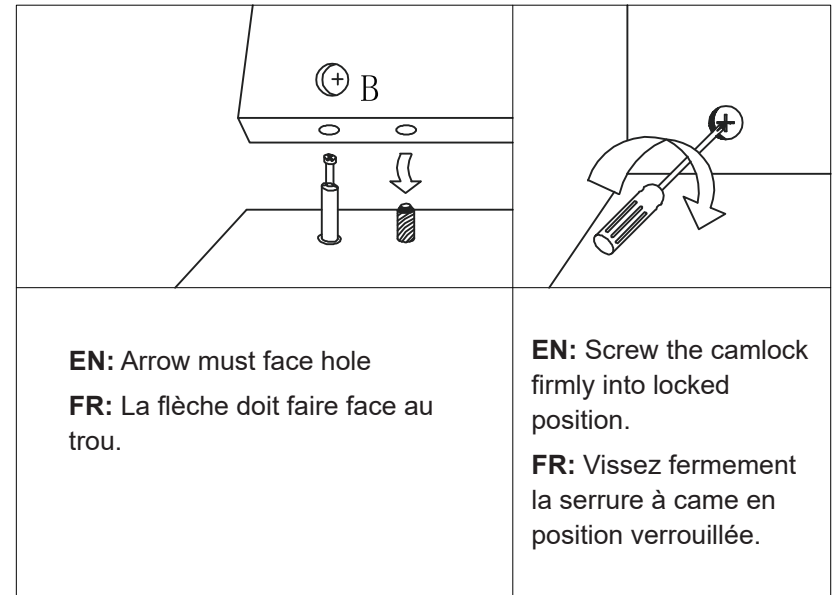
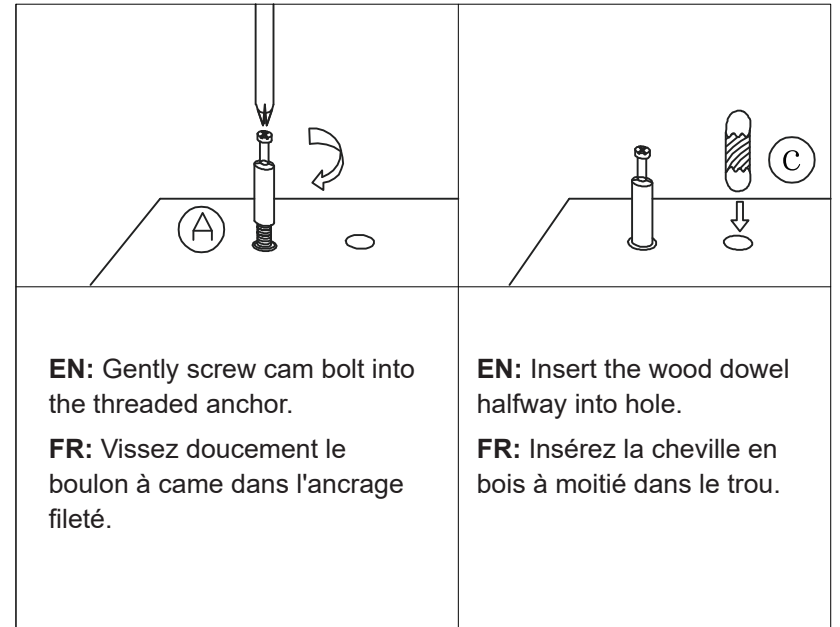

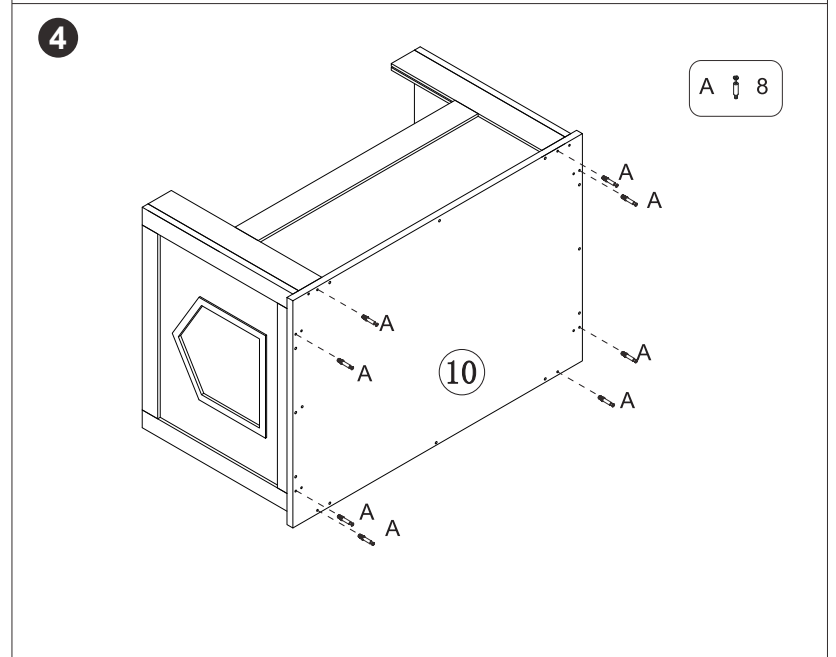
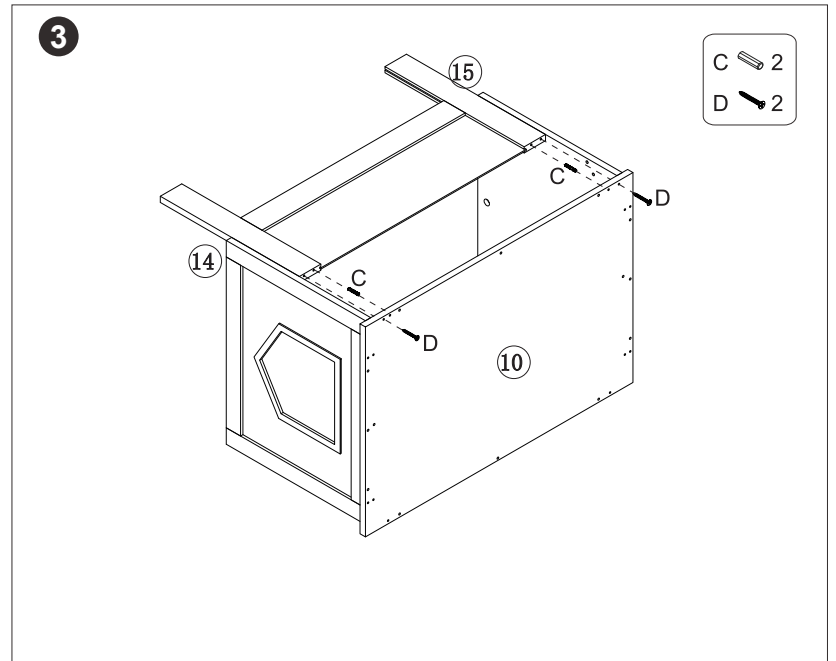
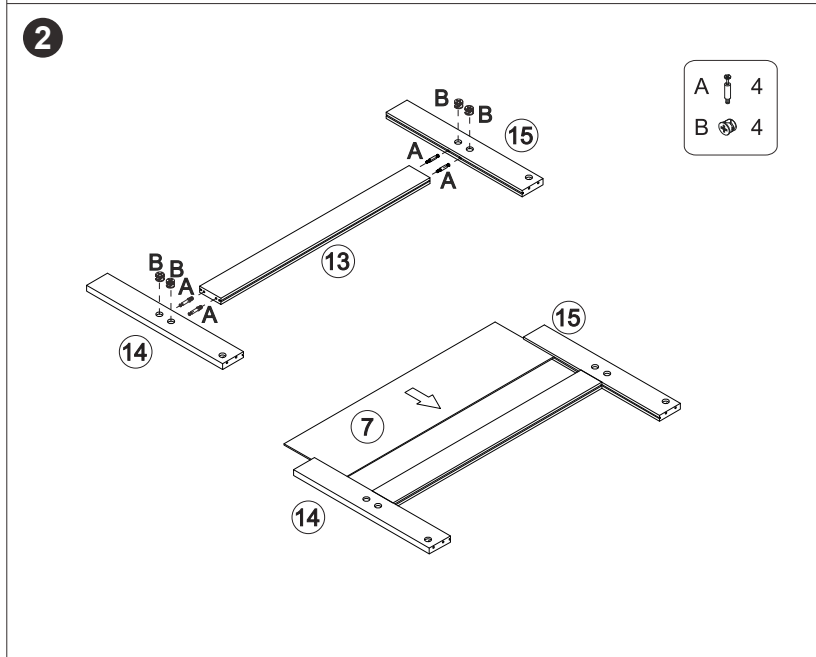
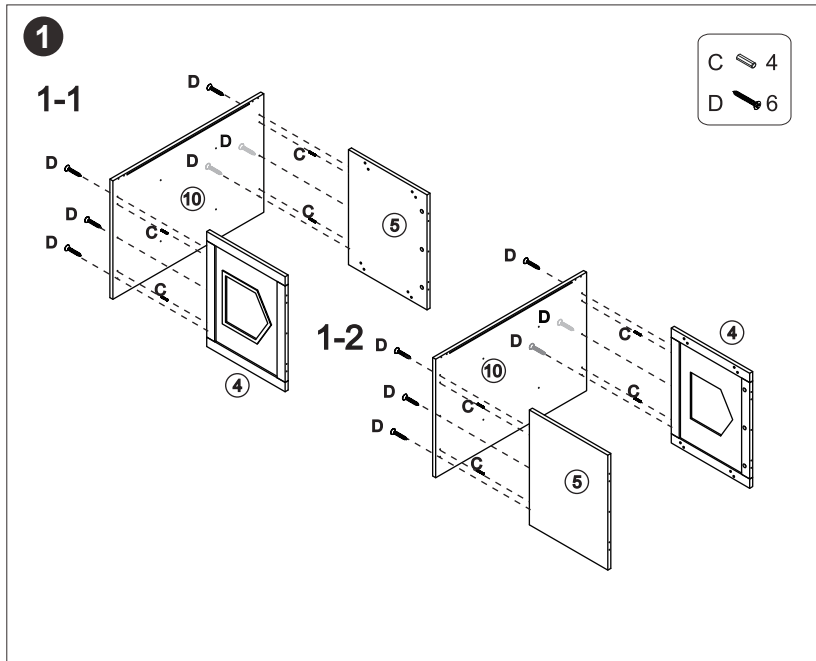

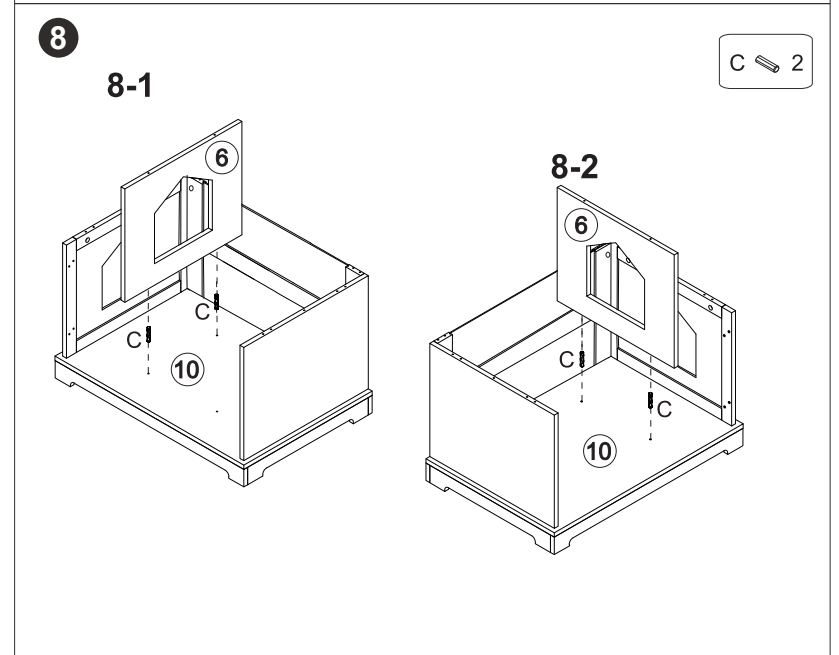
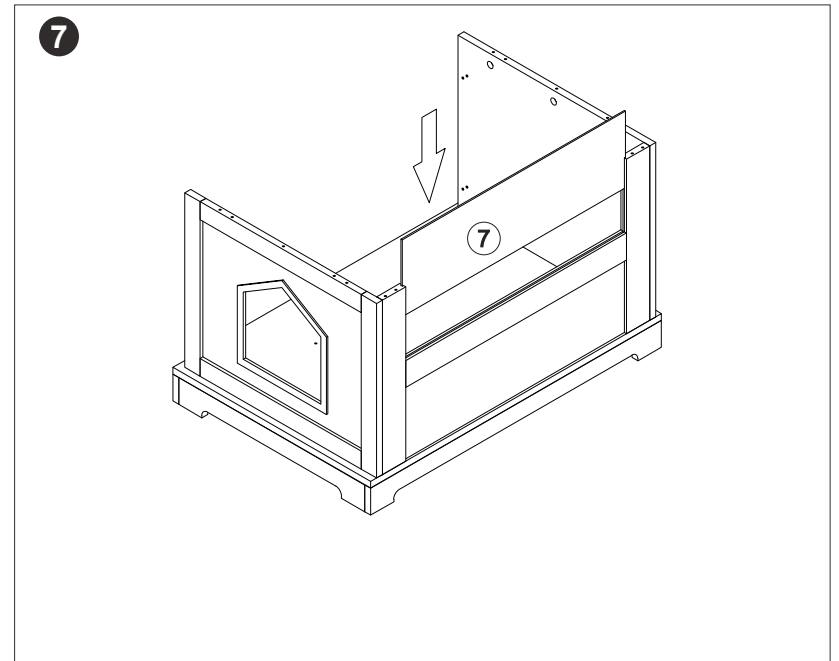
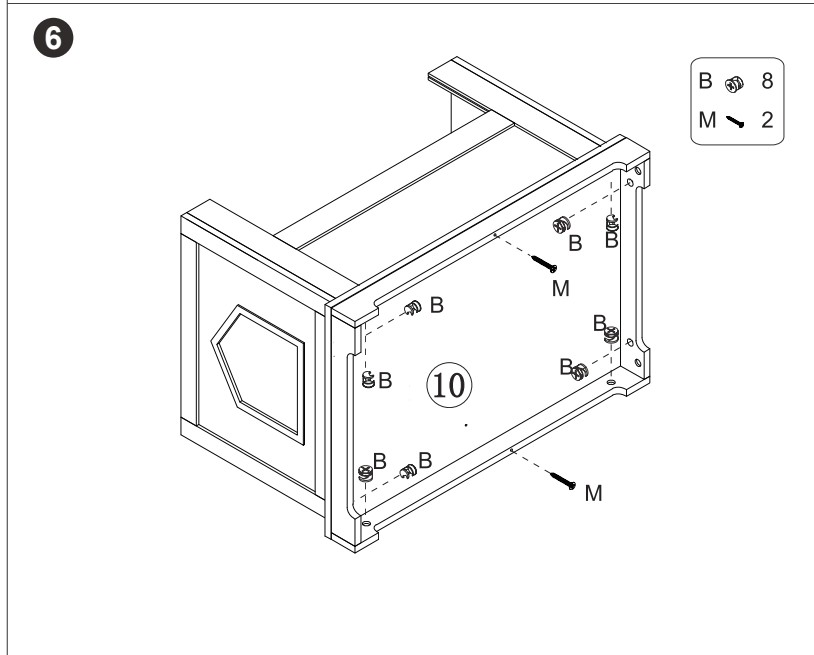
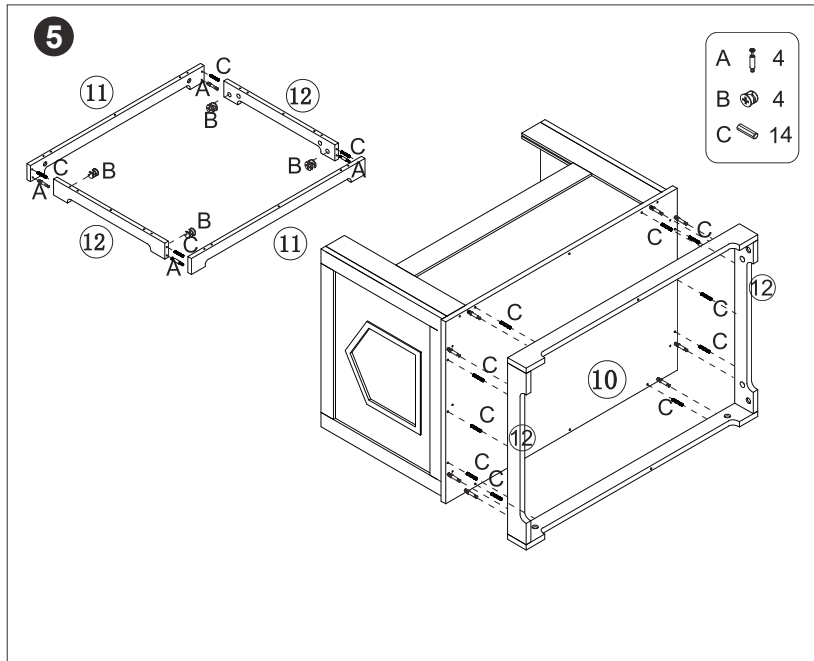

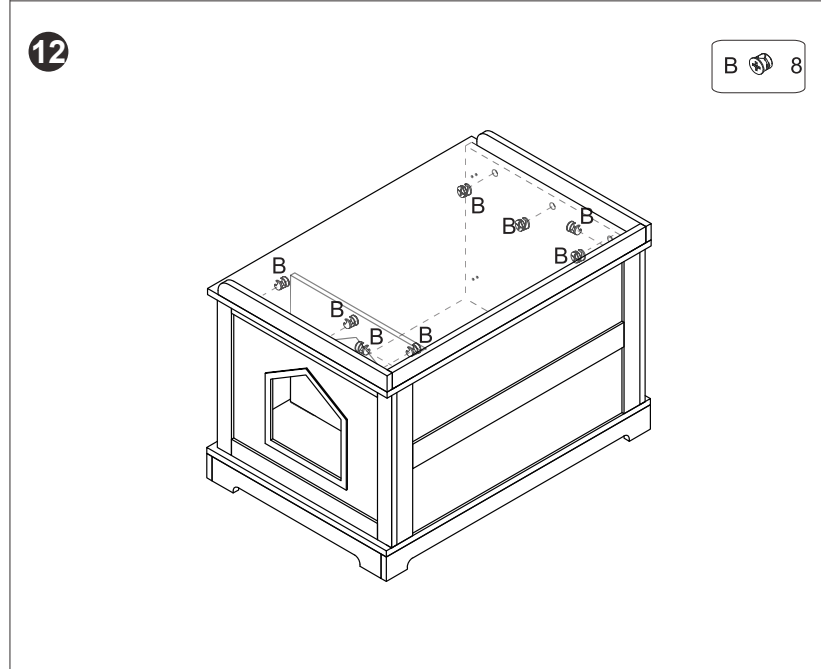
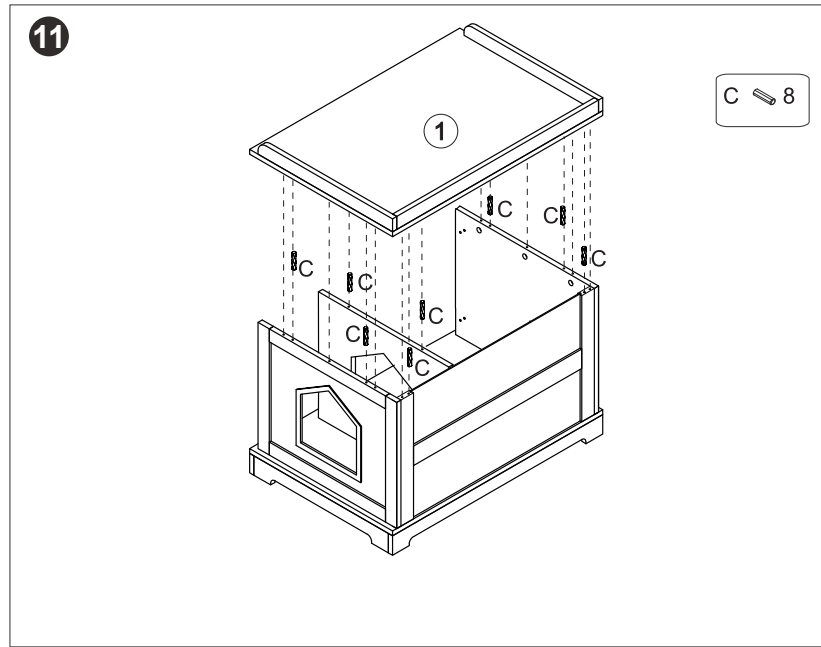
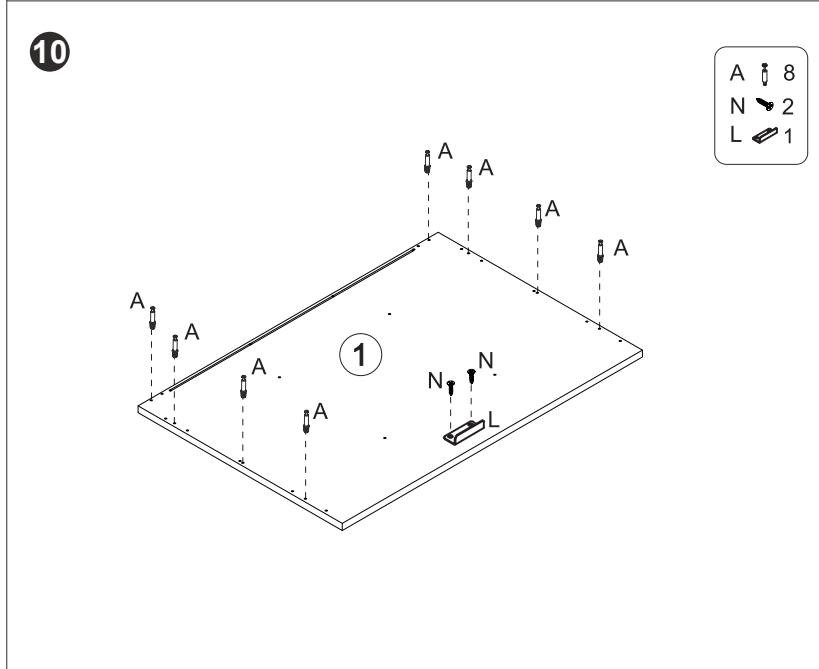
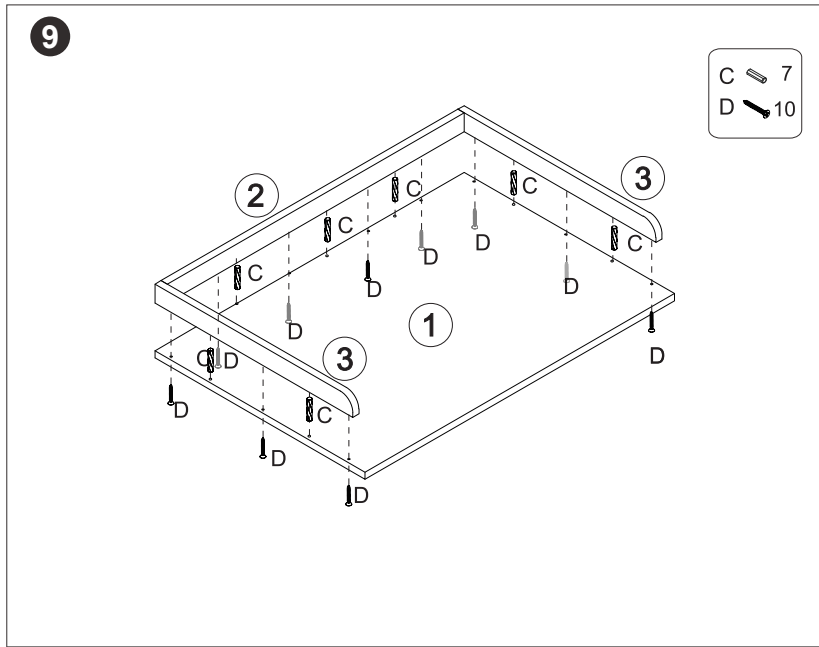

13

**EN:** Advised to leave each screw a little loose in oval hole

**FR:** Conseillé de laisser chaque vis un peu lâche dans le trou ovale.

N	4
F	2
G	2
I	4
K	8

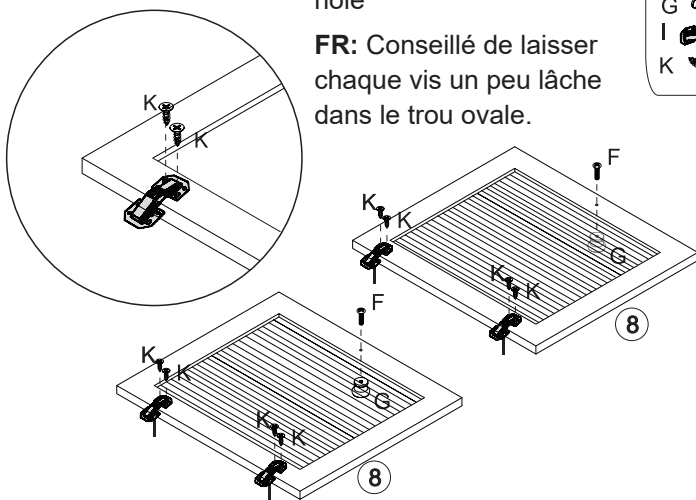

14

**EN: Assemble Left Door** Advised to leave each screw a little loose in oval hole

**FR: Assembler la Porte Gauche** Conseillé de laisser chaque vis un peu lâche dans le trou ovale.

K 4

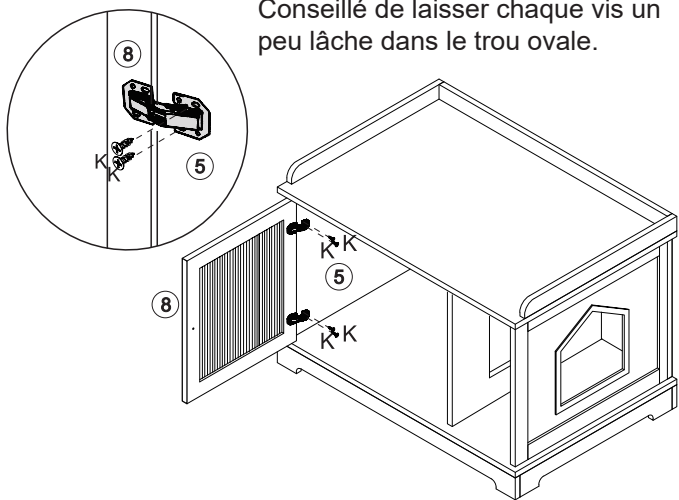

15

**EN: Assemble Right Door**

Advised to leave each screw a little loose in oval hole

**FR: Assembler la Porte Droite**

Conseillé de laisser chaque vis un peu lâche dans le trou ovale.

K 4

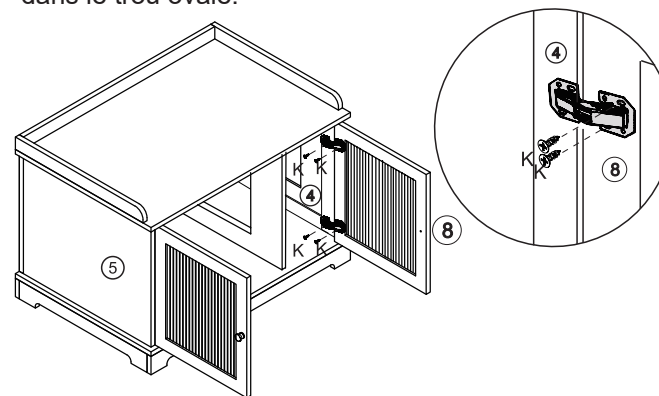

16

**EN:** Don't tighten each screw at the beginning, check the gap between the door and the cabinet, and tighten all of them when they are all coordinate. (If your need to steady this chain hinge, you can drill the two circular holes by yourself)

**FR:** Ne serrez pas chaque vis au début, vérifiez l'écart entre la porte et l'armoire et serrez-les toutes lorsqu'elles sont toutes coordonnées. (Si vous avez besoin de stabiliser cette charnière à chaîne, vous pouvez percer vous-même les deux trous circulaires)

K 8

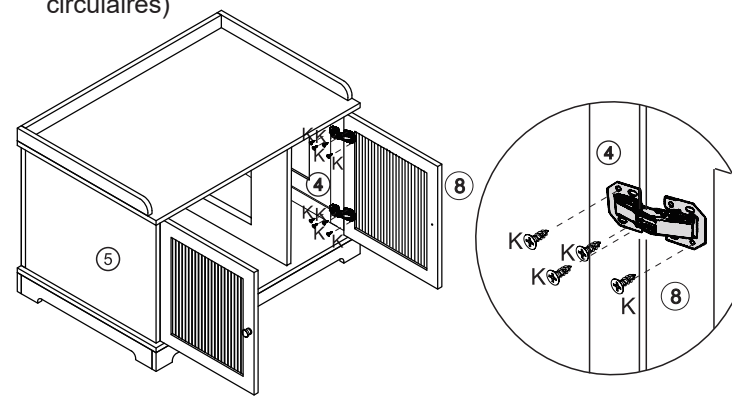

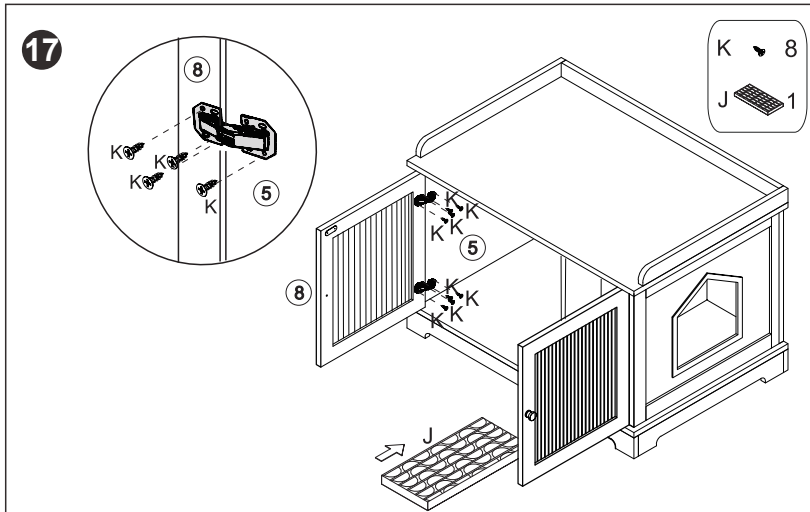

**EN:** Don't tighten each screw at the beginning, check the gap between the door and the cabinet, and tighten all of them when they are all coordinate. (If your need to steady this chain hinge, you can drill the two circular holes by yourself)

**FR:** Ne serrez pas chaque vis au début, vérifiez l'écart entre la porte et l'armoire et serrez-les toutes lorsqu'elles sont toutes coordonnées. (Si vous avez besoin de stabiliser cette charnière à chaîne, vous pouvez percer vous-même les deux trous circulaires)

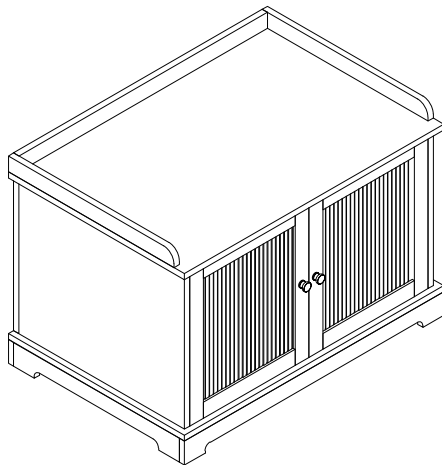

EN



### Return / Damage Claim Instructions

- ⚠ **DO NOT discard the box / original packaging.**  
In case a return is required, the item must be returned in original box. Without this your return will not be accepted.
- ⚠ **Take a photo of the box markings.**  
A photo of the markings (text) on the side of the box is required in case a part is needed for replacement. This helps our staff identify your product number to ensure you receive the correct parts.
- ⚠ **Take a photo of the damaged part (if applicable).**  
A photo of the damage is always required to file a claim and get your replacement or refund processed quickly. Please make sure you have the box even if it is damaged.
- ⚠ **Send us an email with the images requested.**  
Email us directly from marketplace where your item was purchased with the attached images and a description of your claim.

FR



### Instructions De Retour / Réclamation De Dommages

- ⚠ **NE PAS jeter la boîte/l'emballage d'origine.**  
Dans le cas où un retour est requis, l'article doit être retourné dans sa boîte d'origine. Sans cela, votre retour ne sera pas accepté.
- ⚠ **Prenez une photo des marquages de la boîte.**  
Une photo des marquages (texte) sur le côté de la boîte est requise au cas où une pièce serait nécessaire pour le remplacement. Cela aide notre personnel à identifier votre numéro de produit pour s'assurer que vous recevez les bonnes pièces.
- ⚠ **Prenez une photo des dommages (le cas échéant).**  
Une photo des dommages est toujours requise pour déposer une réclamation et obtenir rapidement votre remplacement ou votre remboursement. Assurez-vous d'avoir la boîte même si elle est endommagée.
- ⚠ **Envoyez-nous un e-mail avec les images demandées.**  
Envoyez-nous un e-mail directement depuis le marché où votre article a été acheté avec les images ci-jointes et une description de votre réclamation.