

Table

JV12545





THIS INSTRUCTION BOOKLET CONTAINS **IMPORTANT** SAFETY INFORMATION.
PLEASE READ AND KEEP FOR FUTURE REFERENCE.



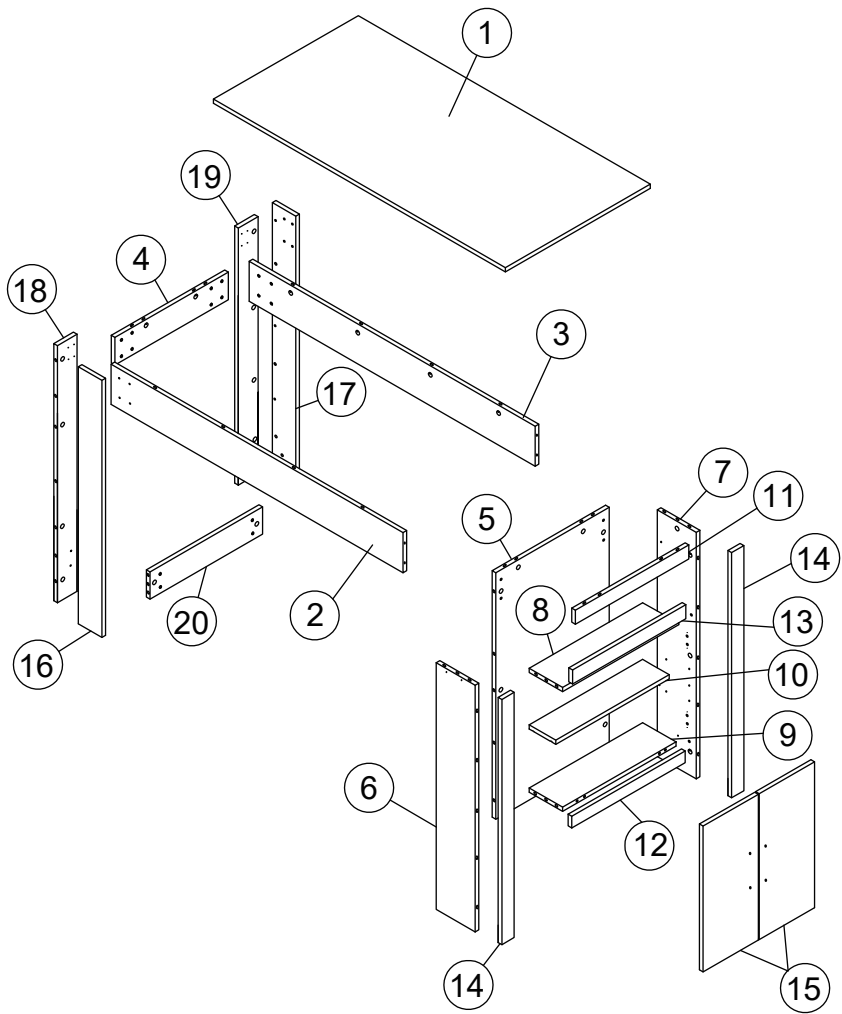

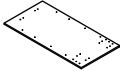
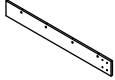
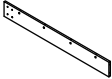

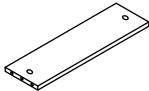
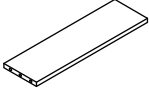
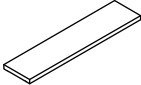
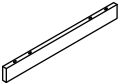
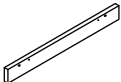

Before You Start

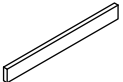
- ⚠ Please read all instructions carefully.
- ⚠ Retain instructions for future reference.
- ⚠ Separate and count all parts and hardware.
- ⚠ Read through each step carefully and follow the proper order.
- ⚠ We recommend that, where possible, all items are assembled near to the area in which they will be placed in use, to avoid moving the product unnecessarily once assembled.
- ⚠ Always place the product on a flat, steady and stable surface.
- ⚠ Keep all small parts and packaging materials for this product away from babies and children as they potentially pose a serious choking hazard.



NO	PART LIST	QTY
1	Table Top 	1
2	Top Support - Front 	1
3	Top Support - Back 	1
4	Top Support - Side 	1
5	Centre Panel 	1
6	Side Panel - Left 	1
7	Side Panel - Right 	1
8	Middle Panel Upper 	1
9	Middle Panel - Lower 	1
10	Shelf Panel 	1
11	Frame - Top Panel 	1
12	Frame - Bottom Panel 	1

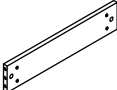











NO	PART LIST	QTY
13	Frame - Middle Panel 	1
14	Frame - Side Panel 	2
15	Door Panel 	2
16	Front Leg - Left 	1
17	Back Leg - Left 	1
18	Front Leg - Right 	1
19	Back Leg - Right 	1
20	Leg Support 	1



Read this instruction carefully. Remove all wrapping material, staples and straps from the carton. See hardware and furniture part list for guidance. Be sure you have all wooden furniture part on a clean and a flat surface, such as carpet or rug, to prevent from being scratched.

CAUTION :



1. Do not Full Tighten the nut or screw until all ready to assemble.
2. Do not Over Tighten the nut or screw to avoid causing damages to the thread.
3. Keep all hardware part of reach of children.

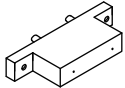

NO	HARDWARE LIST	QTY
A	Plastic U shape Handle 	2
B	Truss Head m4 x 20mm Blk 	4
C	Flat Head Chipboard m3.5 x 12mm Rbw 	15 (+1)
D	Flat Head Chipboard m3.5 x 16mm Rbw 	16 (+1)
E	Flat Head Chipboard Screw m4 x 25mm Rbw 	20 (+1)
F	Flat Head Chipboard Screw m4 x 38mm Rbw 	4
G	Chrome Nickel Hinge 	4
H	Cam Lock D15mm x 9.8mm 	46+(1)
I	Cam Bolt Length 33mm 	46+(1)
J	Hook 	7
K	m5 x 16mm Shelf Support 	4
L	Wood Dowel 6mm x 30mm 	28+(2)

NO	HARDWARE LIST	QTY
M	PVC Block Black 	4
N	Wood Dowel 8mm x 30mm 	12+(1)

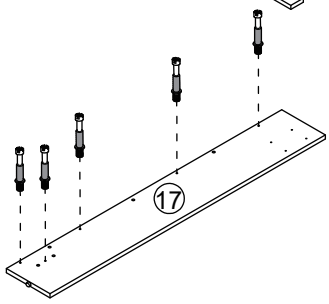
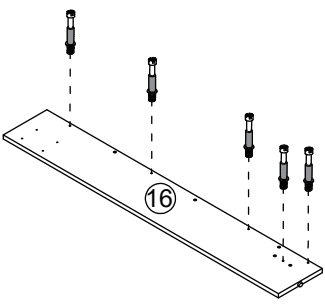
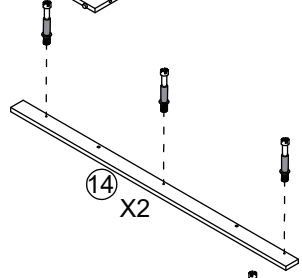
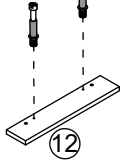
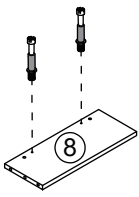
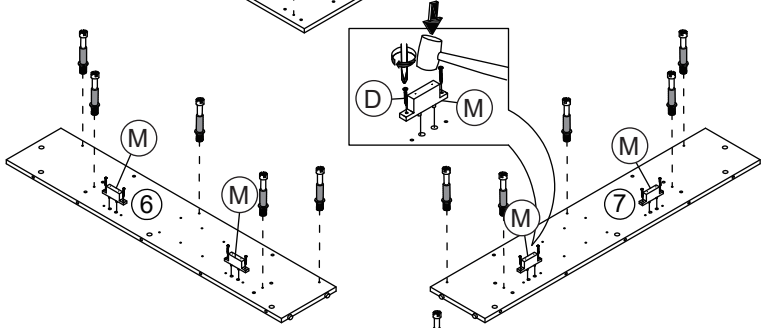
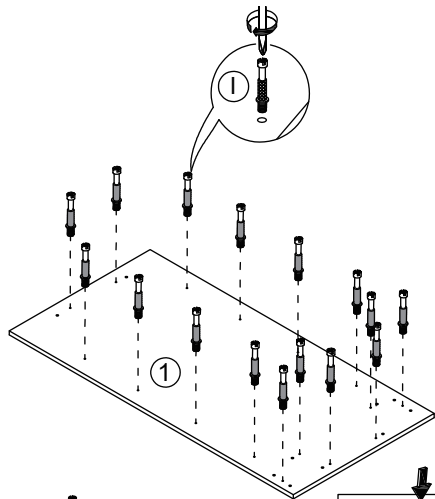

1

(I)		X 46
(D)		X 8
(M)		X 4



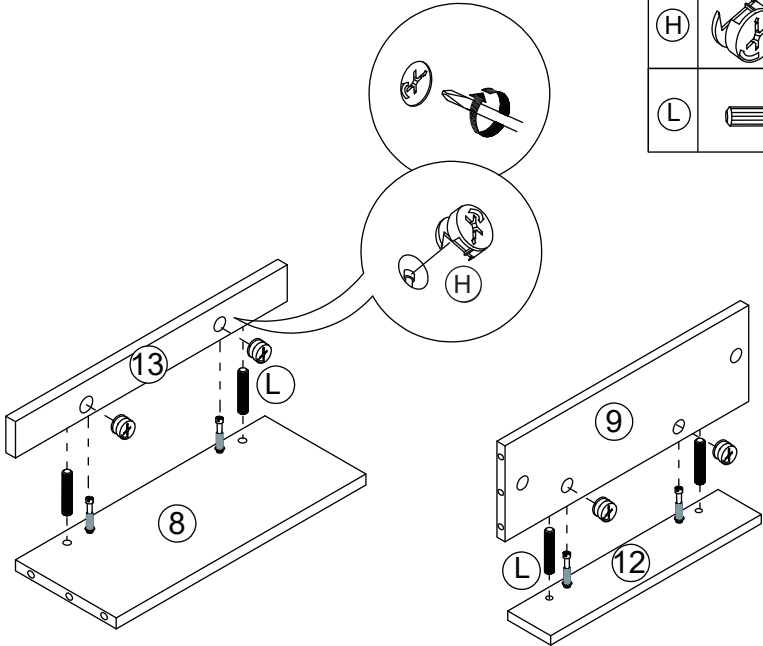

2



(H)	 X 4
(L)	 X 4

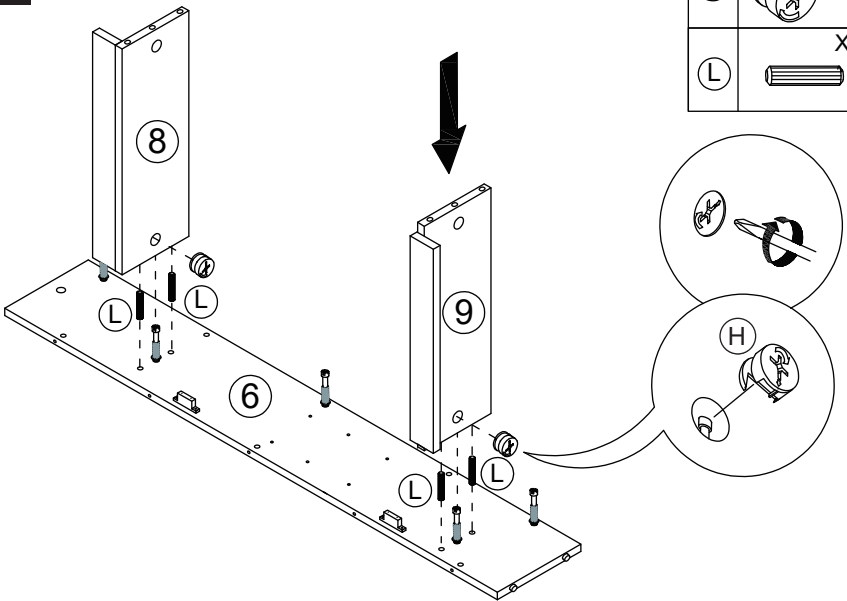

3

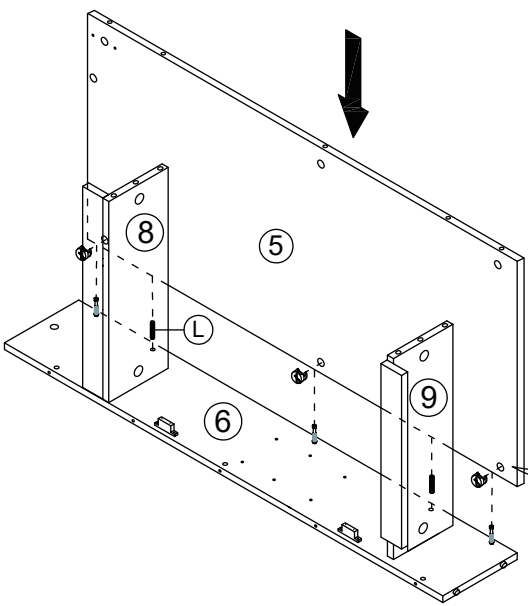

(H)	 X 2
(L)	 X 4

4



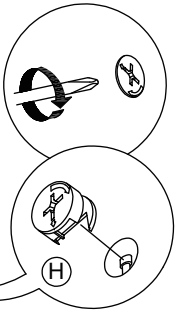

(H)		X 3
(L)		X 2



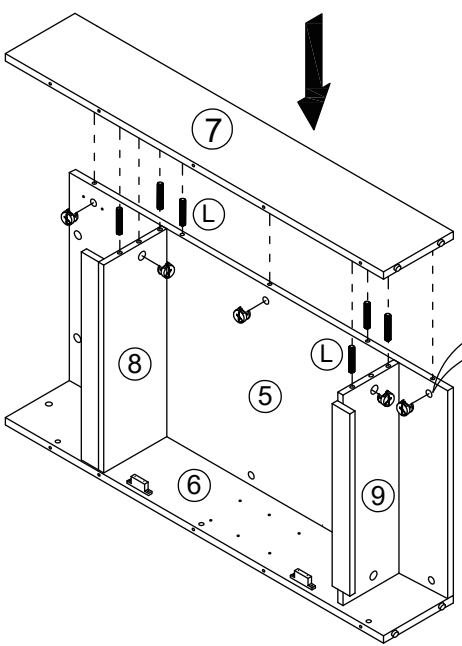

5



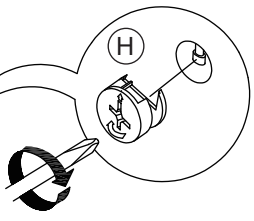

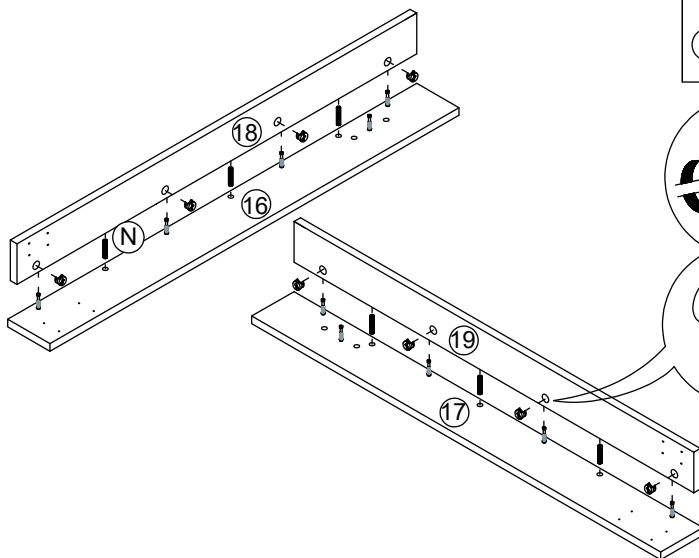

(H)		X 5
(L)		X 6

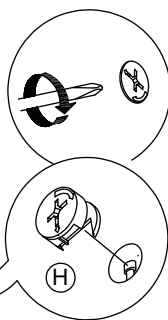
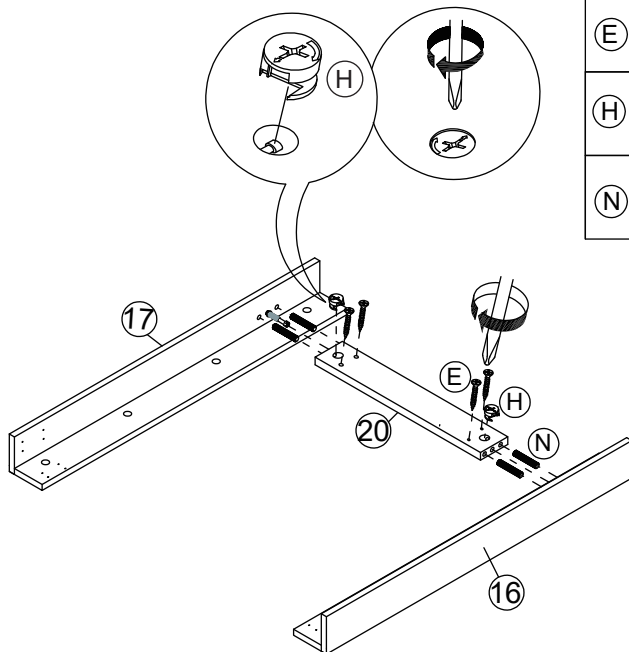

6

(H)	 X 8
(N)	 X 6

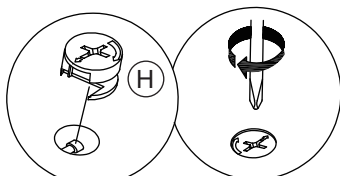

**7**

(E)	 X 4
(H)	 X 2
(N)	 X 4



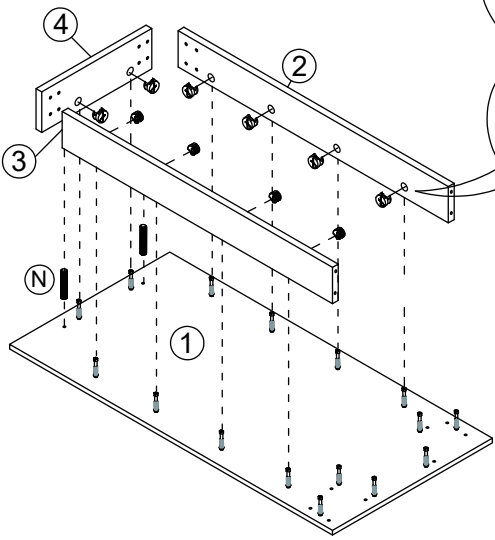

8





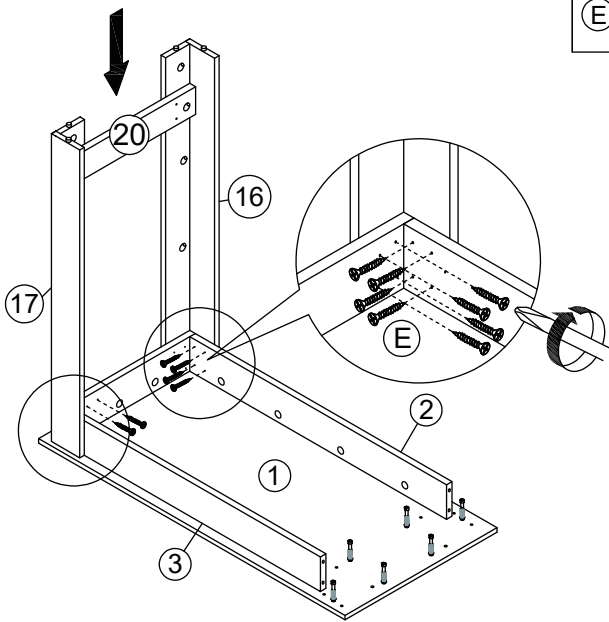

Ⓜ H	 X 10
Ⓜ N	 X 2

9

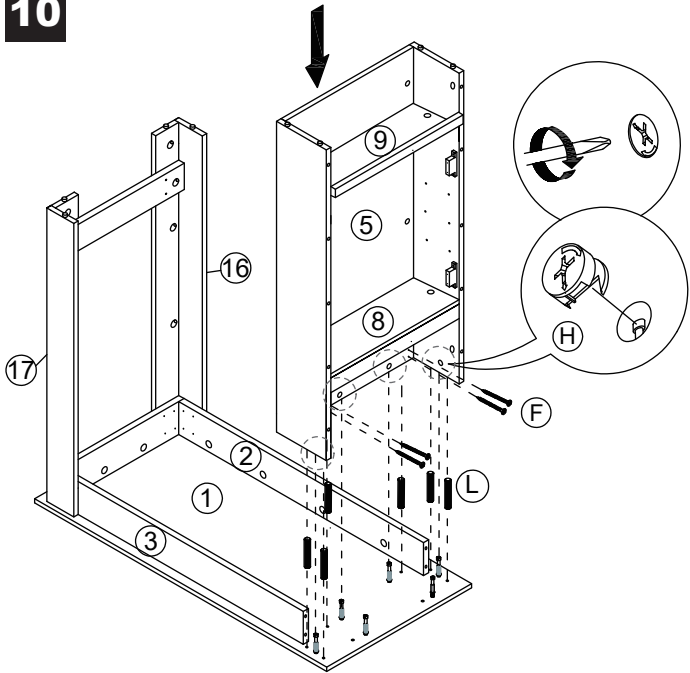



Ⓜ E	 X 16
-----	--

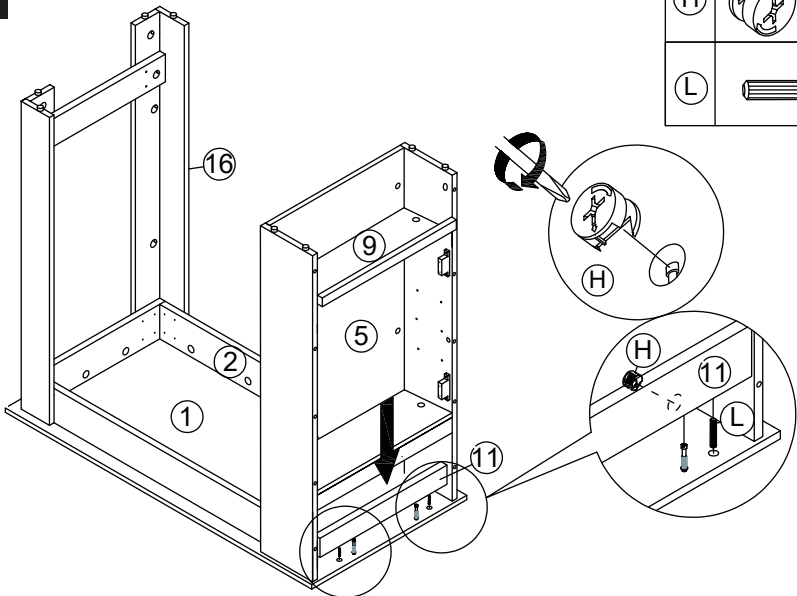

10

(H)		X 4
(L)		X 6
(F)		X 4

11

(H)		X 2
(L)		X 2

12



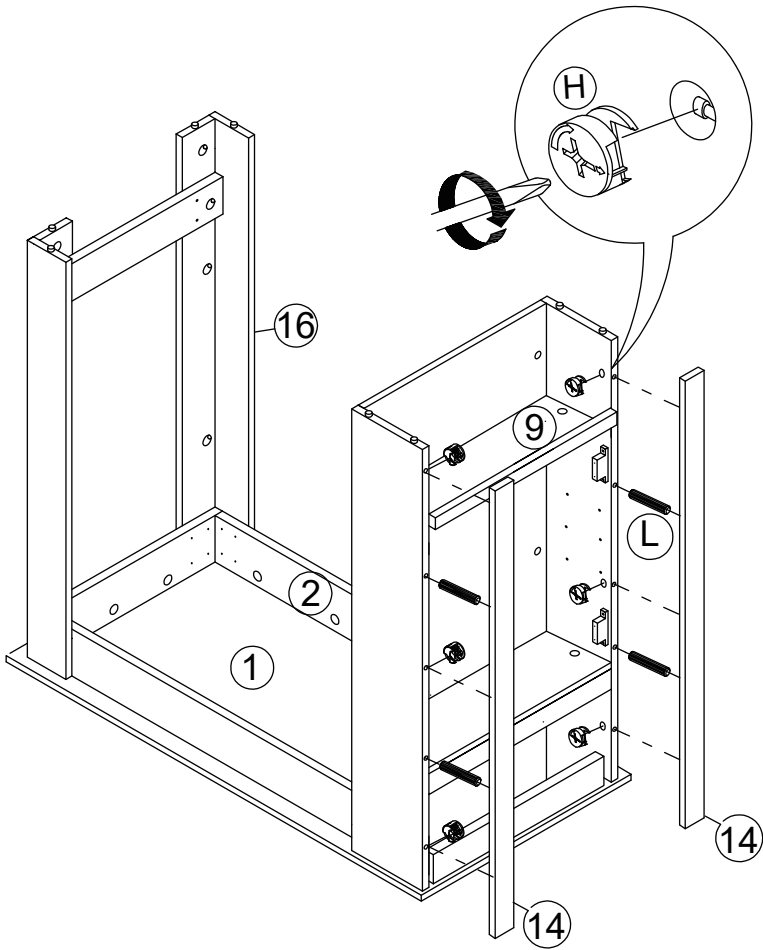

(H)		X 6
(L)		X 4

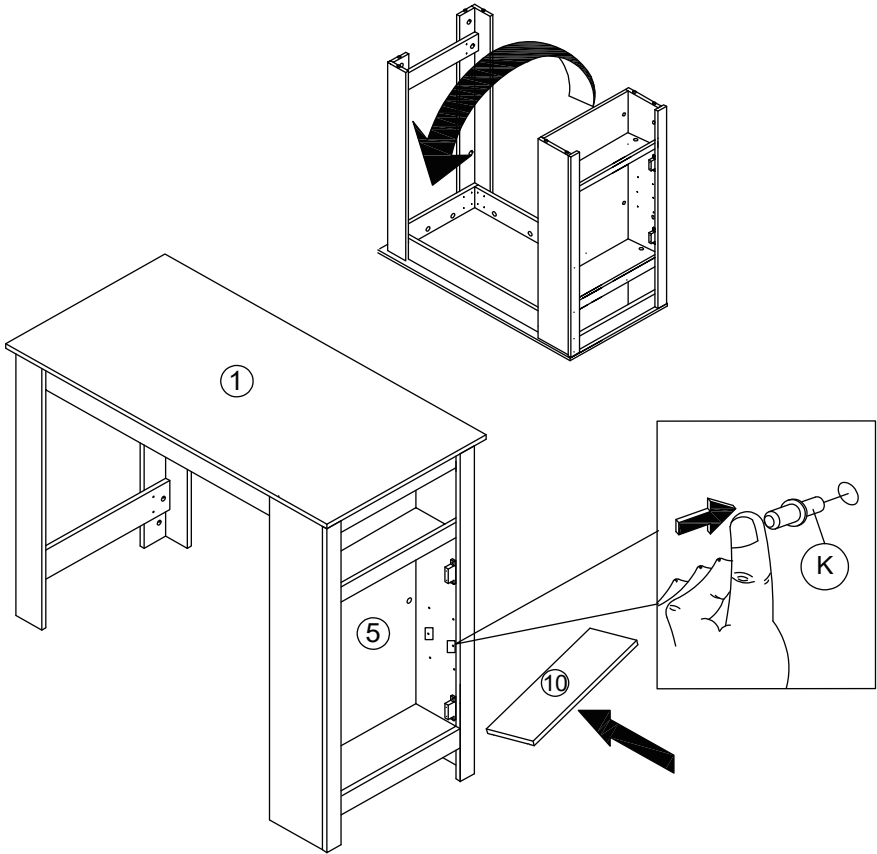

13

(K)	 X 4
-----	---



(A)	 X 2	(C)	 X 8
(B)	 X 4	(G)	 X 4

X2

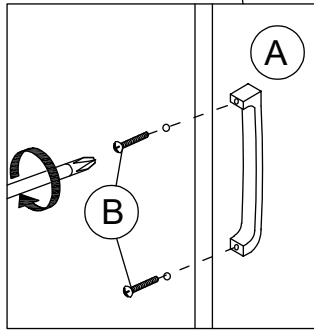
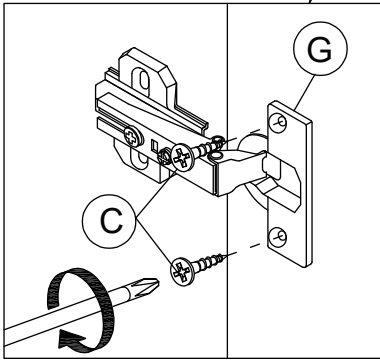
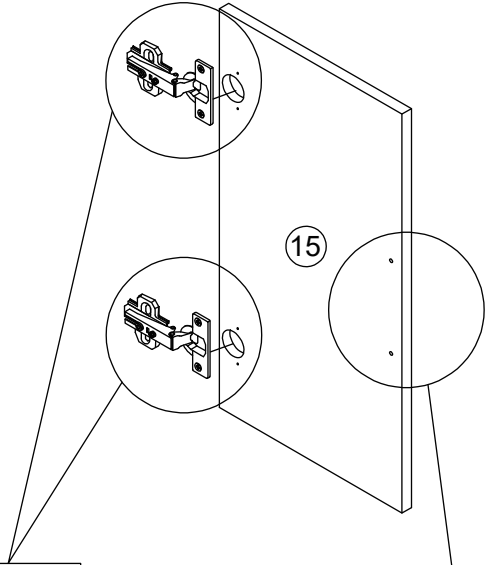

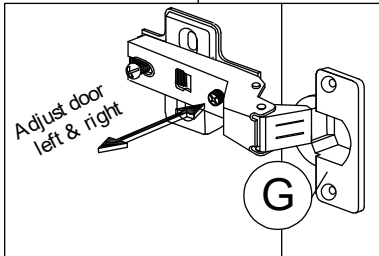
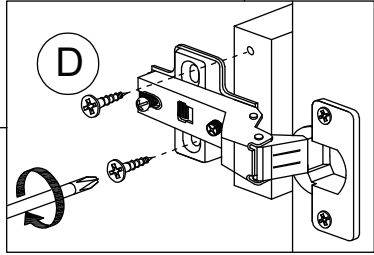
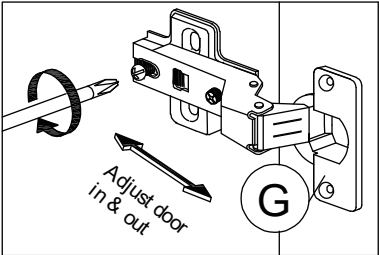
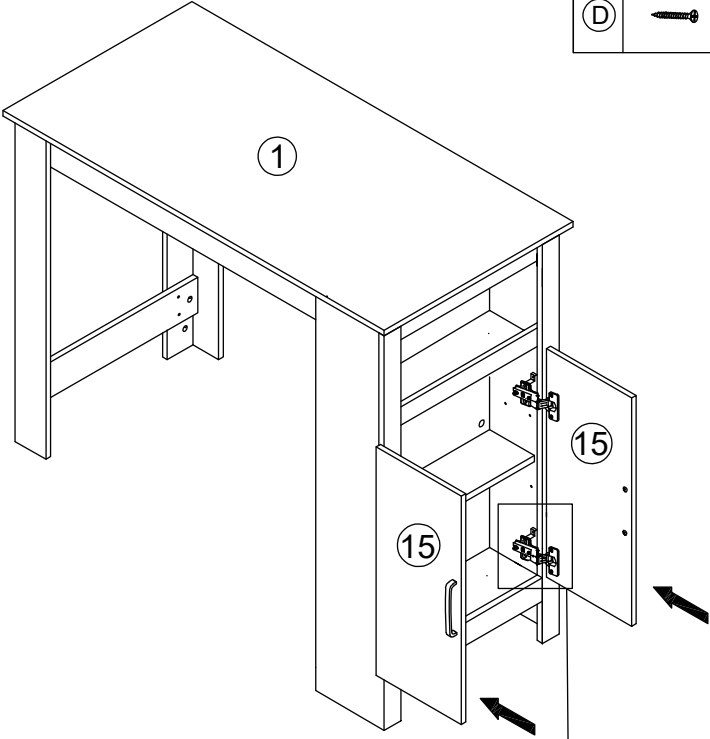

15

(D)		X 8
-----	---	-----



16

(C)		X7
(J)		X7

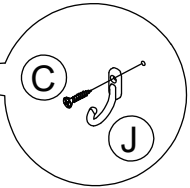
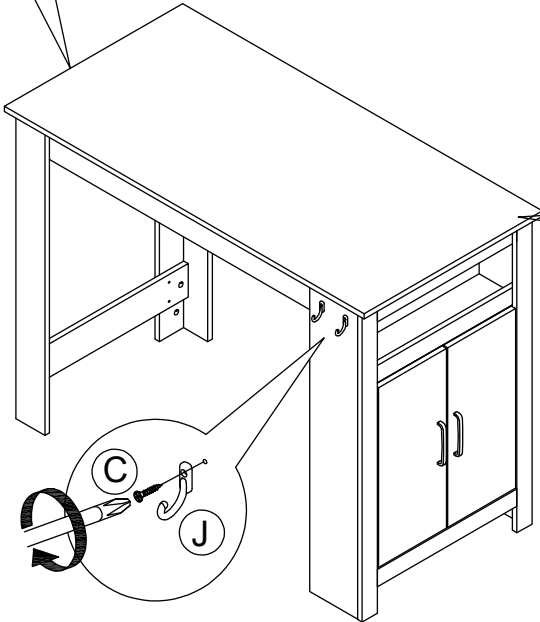
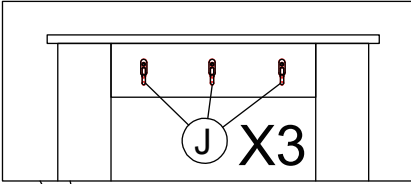

X2

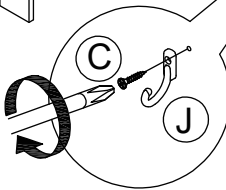

17

COMPLETE ASSEMBLY

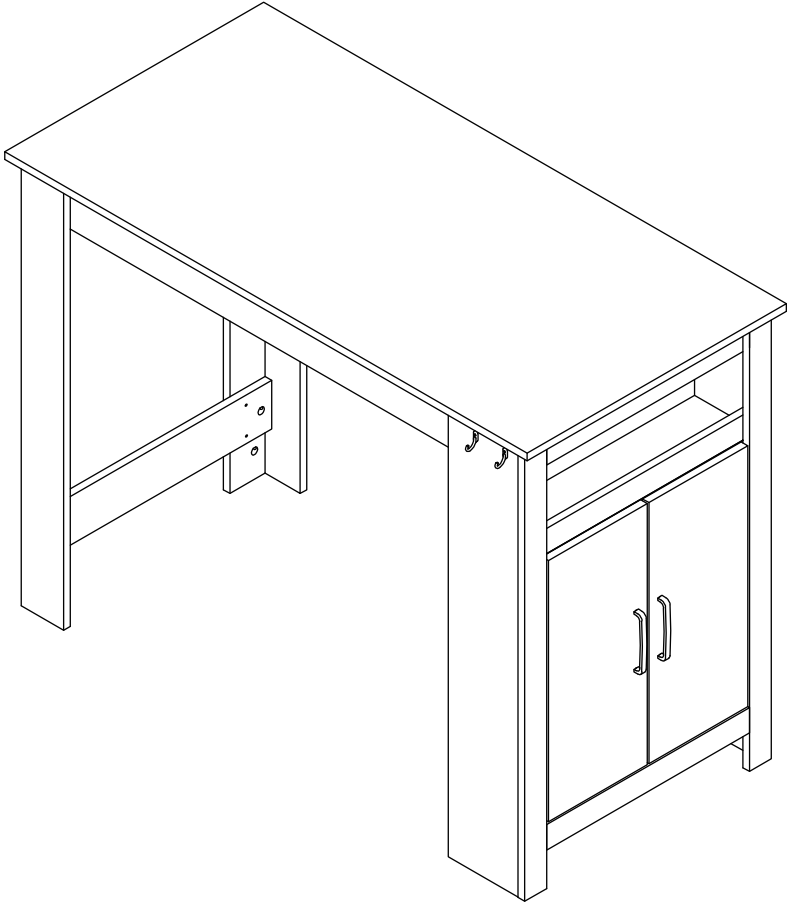

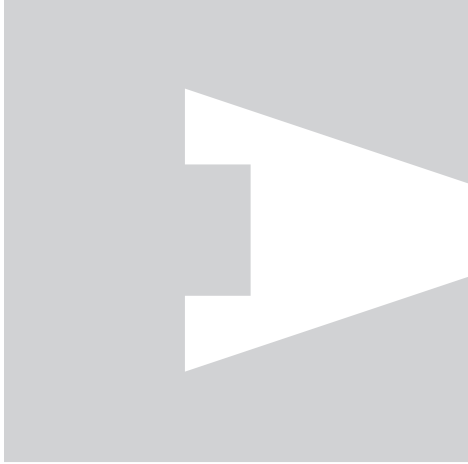

USA office: Fontana **AUS** office: Truganina
GBR office: FDS Corporation Limited, Unit 4, Blackacre
Road, Great Blakenham, Ipswich, IP6 0FL, United Kingdom