

Shoe Storage Cabinet
Armoire de Rangement pour Chaussures

JV13235

THIS INSTRUCTION BOOKLET CONTAINS **IMPORTANT** SAFETY INFORMATION.
PLEASE READ AND KEEP FOR FUTURE REFERENCE.

EN



Before You Start

- ⚠ Please read all instructions carefully.
- ⚠ Retain instructions for future reference.
- ⚠ Separate and count all parts and hardware.
- ⚠ Read through each step carefully and follow the proper order.
- ⚠ We recommend that, where possible, all items are assembled near to the area in which they will be placed in use, to avoid moving the product unnecessarily once assembled.
- ⚠ Always place the product on a flat, steady and stable surface.
- ⚠ Keep all small parts and packaging materials for this product away from babies and children as they potentially pose a serious choking hazard.

FR



Avant de Commencer

- ⚠ Veuillez lire attentivement toutes les instructions.
- ⚠ Conservez les instructions pour vous y référer ultérieurement.
- ⚠ Vérifiez toutes les pièces et les accessoires.
- ⚠ Lisez attentivement chaque étape et suivez l'ordre correct.
- ⚠ Nous recommandons que, dans la mesure du possible, tous les produits soient assemblés à proximité de la zone où ils seront utilisés, afin d'éviter tout déplacement inutile du produit une fois assemblé.
- ⚠ Placez toujours le produit sur une surface plane et stable.
- ⚠ Conservez toutes les petites pièces de ce produit et les matériaux d'emballage hors de portée des bébés et des enfants, car ils pourraient présenter un risque d'étouffement.

HARDWARE LIST / LISTE DE QUINCAILLERIE

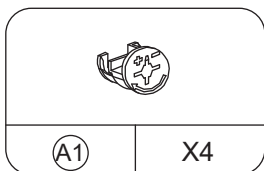

MINIFIX 5654+5546
/MINIFIX 5654+5546

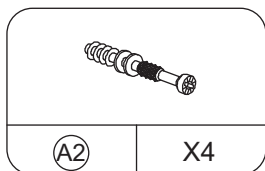

QUICK-FIT CAP
/CAPUCHON À FIXATION RAPIDE

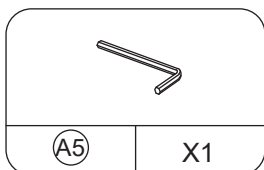
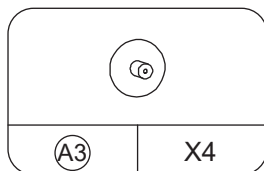

ALLEN KEY
/CLÉ ALLEN

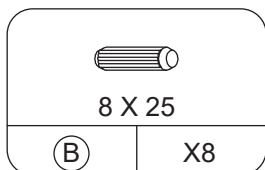

WOOD DOWEL
/GOUPILLE EN BOIS

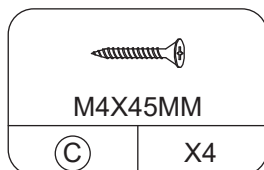

CB SCREW
/CB VIS

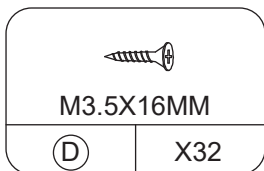

CB SCREW
/CB VIS

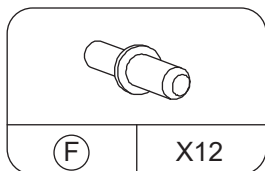

SHELF SUPPORT
/SUPPORT D'ÉTAGÈRE

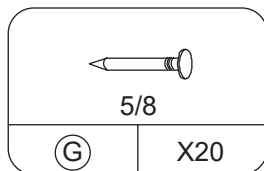

NAIL
/CLOU

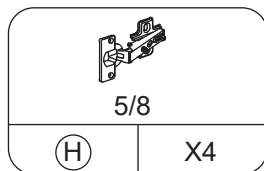

HINGE
/CHARNIÈRES

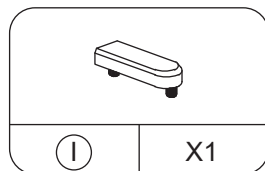

2 PIN STOPPER
/BUTÉE À 2 BROCHES

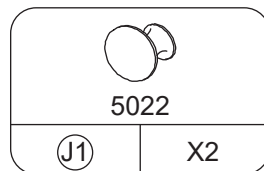

METAL HANDLE
/POIGNÉE MÉTALLIQUE

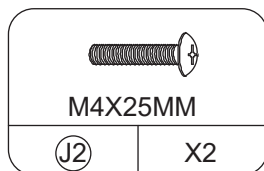

HANDLE SCREW
/VIS DE LA POIGNÉE

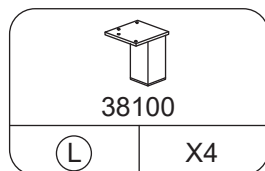

PVC LEG
/PIED EN PVC

PARTS LIST / LISTE DES PIÈCES

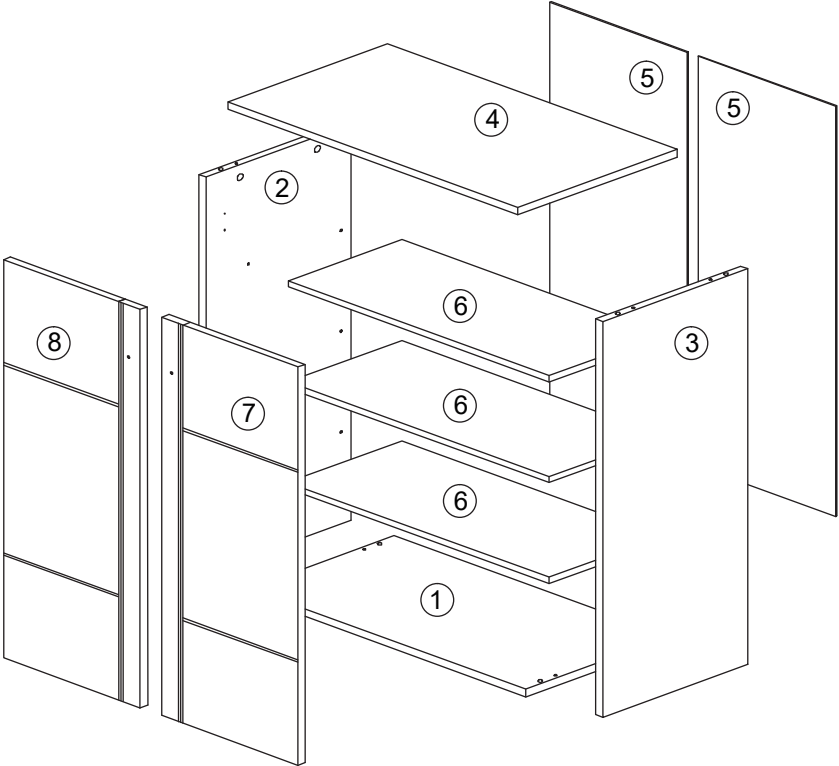

1

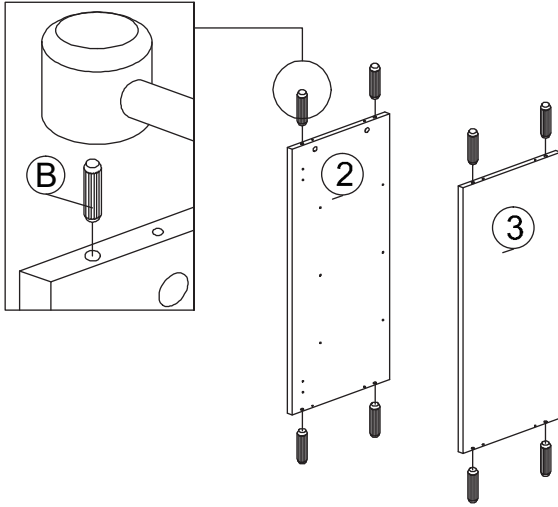

2

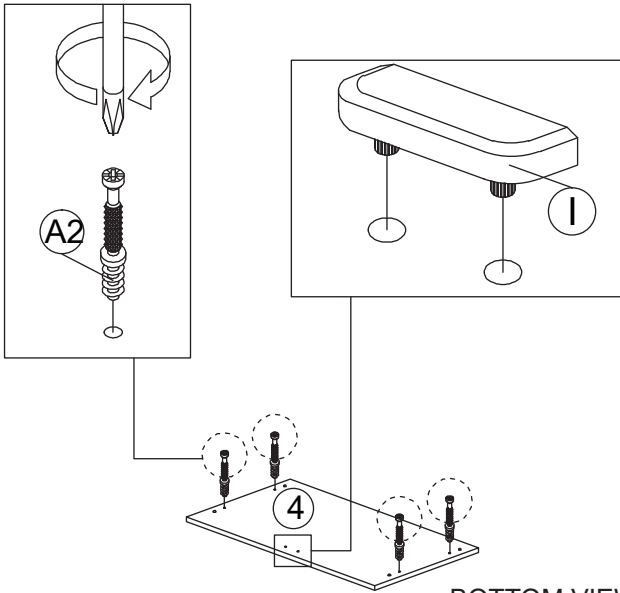

BOTTOM VIEW
/VUE DE DESSOUS

3

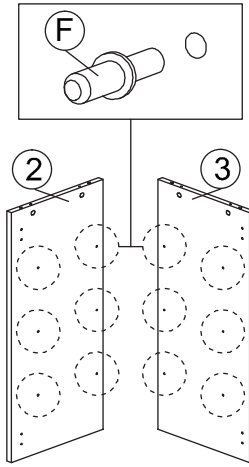

4

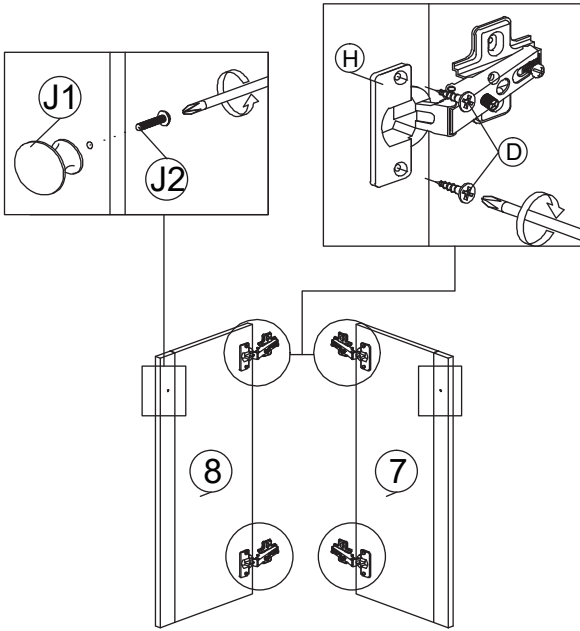

BACK VIEW
VUE ARRIÈRE

5

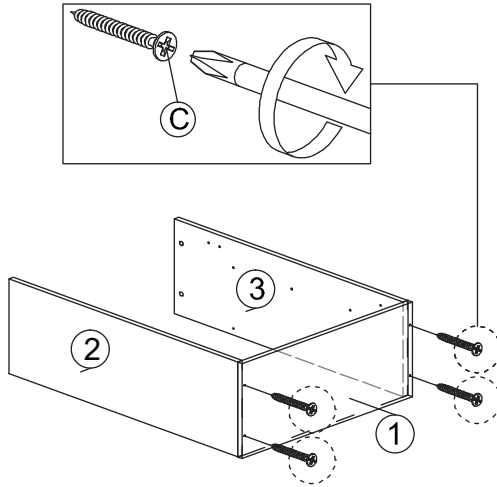

BOTTOM VIEW
/VUE DE DESSOUS

6

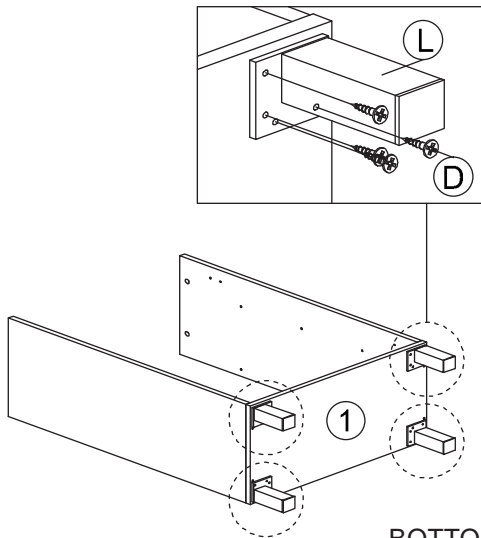

BOTTOM VIEW
/VUE DE DESSOUS

7

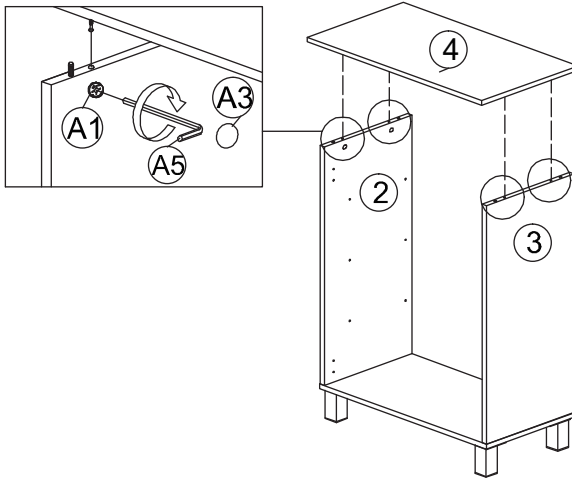

8

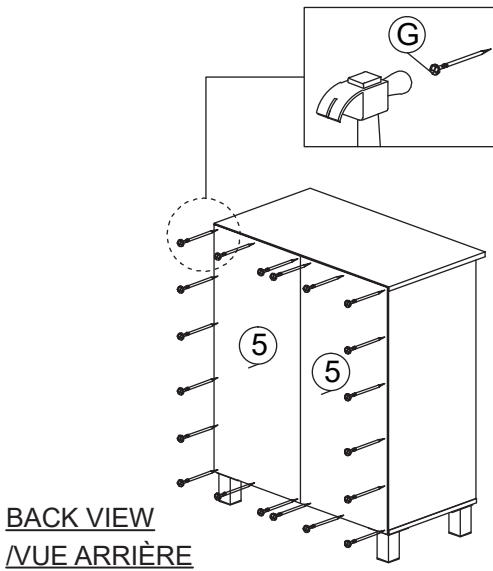

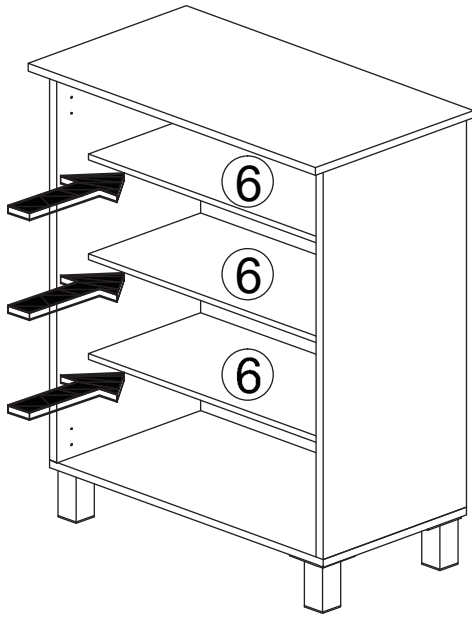

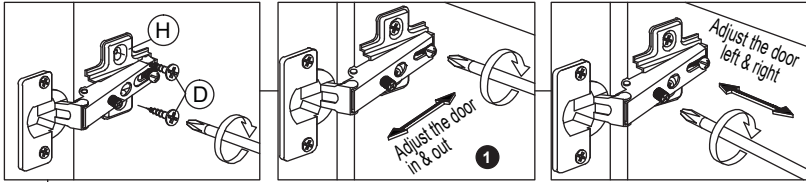

1 Adjust the door panel inward or outward /Réglez le panneau de porte vers l'intérieur ou l'extérieur

2 Adjust the door panel left or right /Réglez le panneau de porte vers la gauche ou la droite

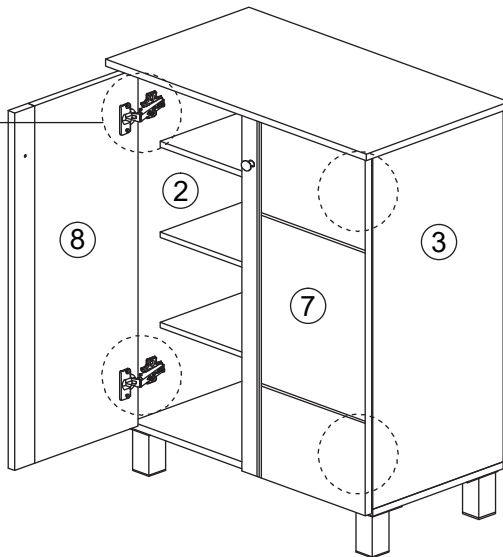

COMPLETE /TERMINÉ

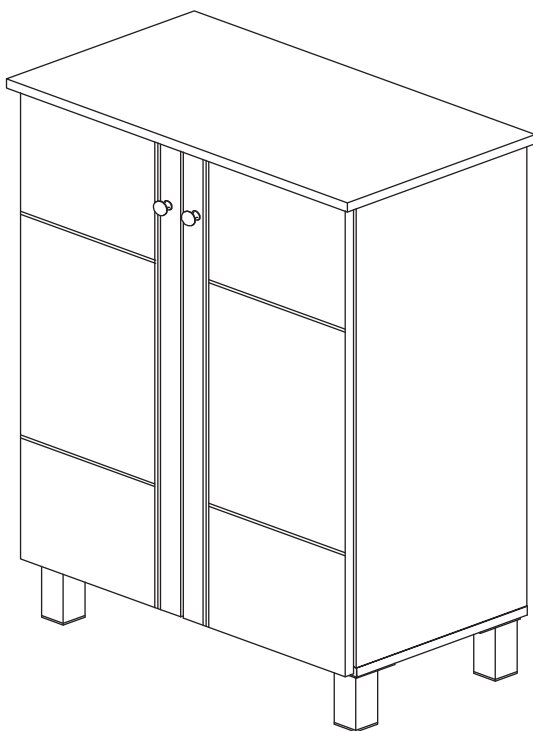

Installation of Anti-Tip Restraint

Kit includes:

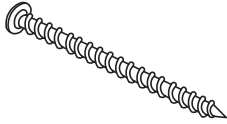

A (x1)
Long screw

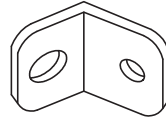

B (x2)
Mounting bracket

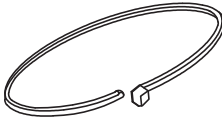

C (x1)
Restraint strap



D (x1)
Short screw



WARNING



Serious or fatal crushing injuries can occur from furniture tip - over. To help prevent tip - over:

- Install tip - over restraint provided
- Place heaviest items in the lower drawers
- Do not set TVs or other heavy objects on top of this product
- Never allow children to climb or hang on drawers, doors or shelves
- Never open more than one drawer at a time
- Do not defeat or remove the drawer interlock system

Using tip - over restraints may only reduce but not eliminate the risk of tip - over.

IMPORTANT: Use of this safety kit is mandatory. This restraint is not a substitute for proper adult supervision. Failure to detach this restraint before moving furniture may result in injury and damage.

FITTING OF ANTI-TIP SAFETY STRAP

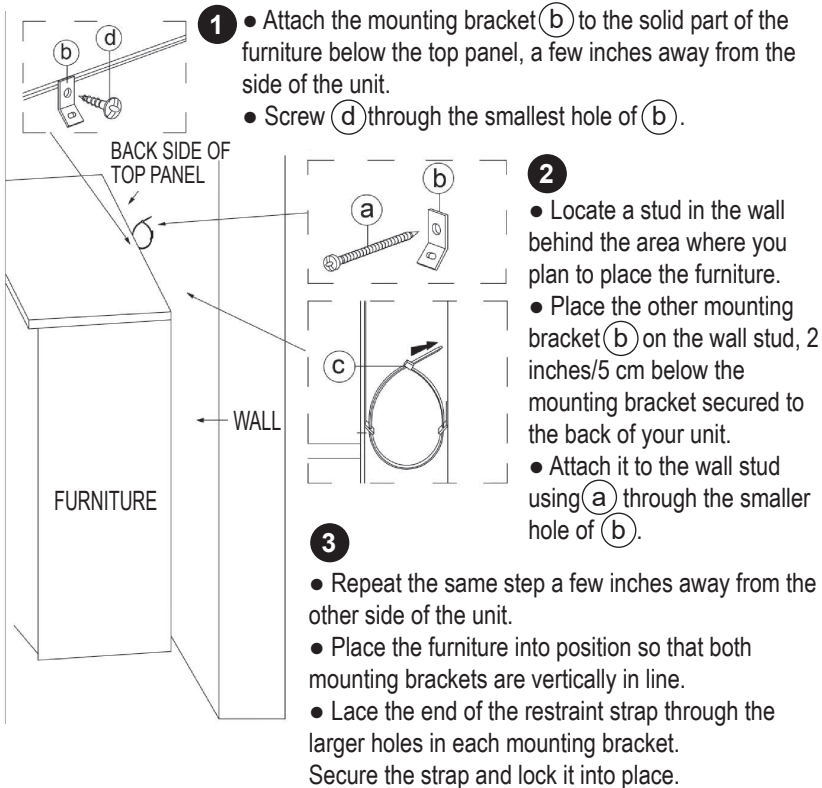

(a) X1



TP 8#x2"
Screw

(b) X2

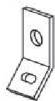

Mounting
bracket

(c) X1



Restraint
strap

(d) X1



TP 6#x5/8"
Screw

Installation du Dispositif Anti-basculement

Le kit comprend:

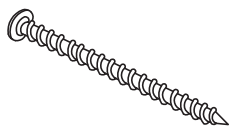

A (x1)
Vis longue

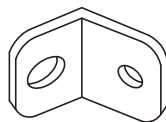

B (x2)
Support de montage

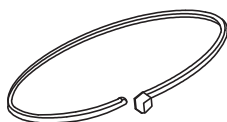

C (x1)
Sangle de sécurité



D (x1)
Vis courte



AVERTISSEMENT



Le renversement d'un meuble peut entraîner des blessures graves, voire mortelles. Pour éviter que le meuble ne se renverse:

- Installez le dispositif anti-basculement fourni
- Placez les objets les plus lourds dans les tiroirs inférieurs
- Ne placez pas de téléviseurs ou d'autres objets lourds sur ce produit
- Ne laissez jamais les enfants grimper ou s'accrocher aux tiroirs, aux portes ou aux étagères
- N'ouvrez jamais plus d'un tiroir à la fois
- Ne désactivez pas et ne retirez pas le système de verrouillage des tiroirs

L'utilisation de dispositifs anti-basculement ne peut que réduire, mais pas éliminer, le risque de basculement.

IMPORTANT: L'utilisation de ce kit de sécurité est obligatoire. Ce système de retenue ne remplace pas la surveillance d'un adulte. Si ce système de retenue n'est pas retiré avant de déplacer le meuble, des blessures et des dommages peuvent survenir.

INSTALLATION DE LA SANGLE DE SÉCURITÉ ANTI-RENVERSEMENT

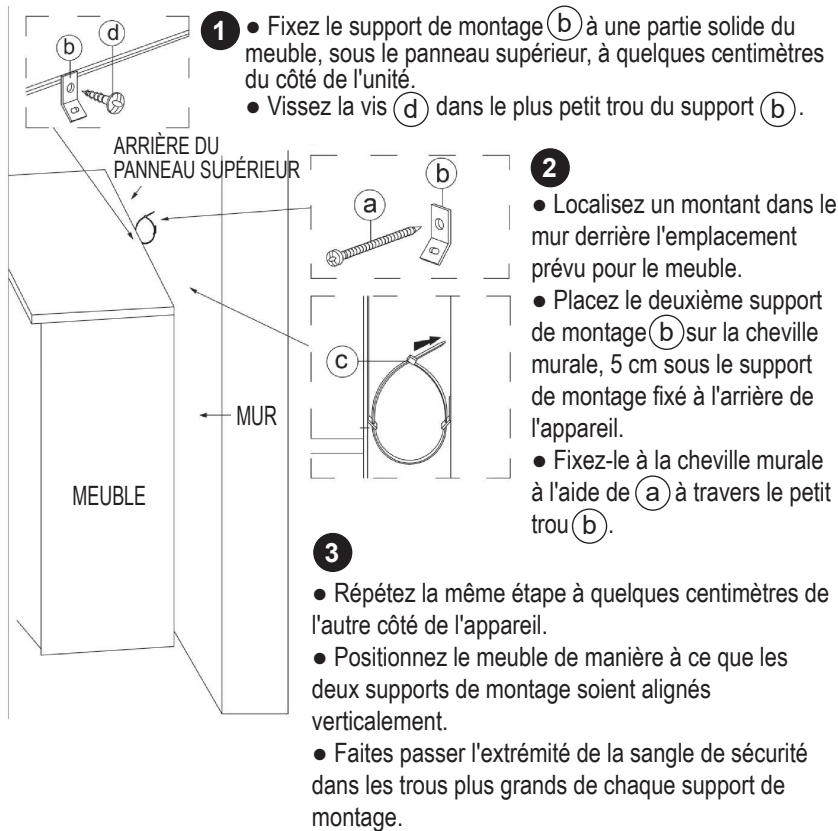

(a) X1



TP 8#x2"
Vis

(b) X2



Support de
montage

(c) X1



Sangle de
sécurité

(d) X1



TP 6#x5/8"
Vis

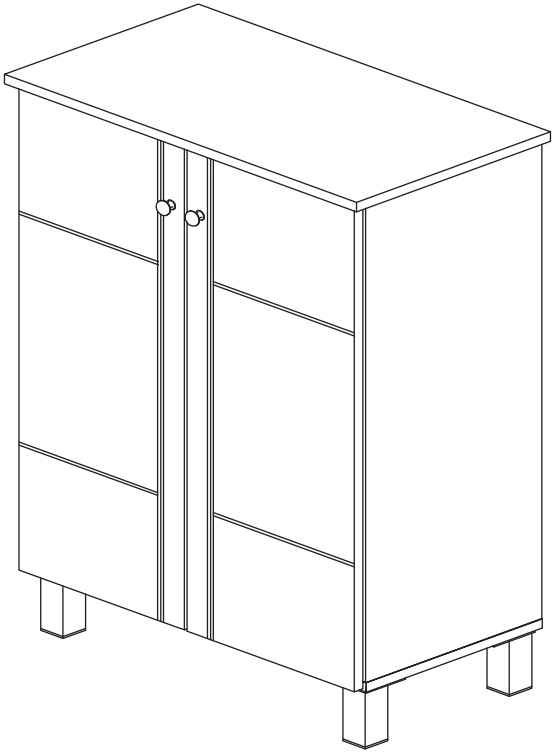



Return / Damage Claim Instructions

⚠ DO NOT discard the box / original packaging.

In case a return is required, the item must be returned in original box. Without this your return will not be accepted.

⚠ Take a photo of the box markings.

A photo of the markings (text) on the side of the box is required in case a part is needed for replacement. This helps our staff identify your product number to ensure you receive the correct parts.

⚠ Take a photo of the damaged part (if applicable).

A photo of the damage is always required to file a claim and get your replacement or refund processed quickly. Please make sure you have the box even if it is damaged.

⚠ Send us an email with the images requested.

Email us directly from marketplace where your item was purchased with the attached images and a description of your claim.



Instructions De Retour / Réclamation De Dommages

⚠ NE PAS jeter la boîte/l'emballage d'origine.

Dans le cas où un retour est requis, l'article doit être retourné dans sa boîte d'origine. Sans cela, votre retour ne sera pas accepté.

⚠ Prenez une photo des marquages de la boîte.

Une photo des marquages (texte) sur le côté de la boîte est requise au cas où une pièce serait nécessaire pour le remplacement. Cela aide notre personnel à identifier votre numéro de produit pour s'assurer que vous recevez les bonnes pièces.

⚠ Prenez une photo des dommages (le cas échéant).

Une photo des dommages est toujours requise pour déposer une réclamation et obtenir rapidement votre remplacement ou votre remboursement. Assurez-vous d'avoir la boîte même si elle est endommagée.

⚠ Envoyez-nous un e-mail avec les images demandées.

Envoyez-nous un e-mail directement depuis le marché où votre article a été acheté avec les images ci-jointes et une description de votre réclamation.

USA office: Fontana **AUS** office: Truganina **FRA** office: Saint Vigor d'Ymonville
GBR office: FDS Corporation Limited, Unit 4, Blackacre Road, Great Blakenham,
Ipswich, IP6 0FL, United Kingdom

If you're having difficulty, our friendly
customer team is always here to help.



USA:cs.us@costway.com
AUS:cs.au@costway.com
GBR:cs.uk@costway.com
FRA:cs.fr@costway.com