

4PCS WOODEN ARM SOFA SET
HW71628

THIS INSTRUCTION BOOKLET CONTAINS **IMPORTANT** SAFETY INFORMATION.
PLEASE READ AND KEEP FOR FUTURE REFERENCE.



Before You Start

- ⚠ Please read all instructions carefully.
- ⚠ Retain instructions for future reference.
- ⚠ Separate and count all parts and hardware.
- ⚠ Read through each step carefully and follow the proper order.
- ⚠ We recommend that, where possible, all items are assembled near to the area in which they will be placed in use, to avoid moving the product unnecessarily once assembled.
- ⚠ Always place the product on a flat, steady and stable surface.
- ⚠ Keep all small parts and packaging materials for this product away from babies and children as they potentially pose a serious choking hazard.

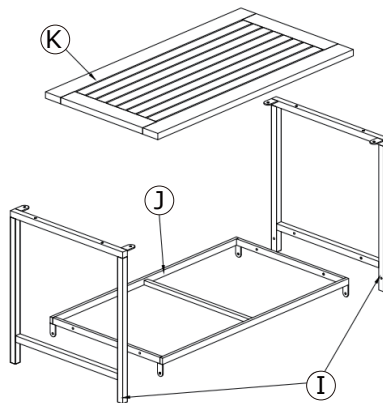
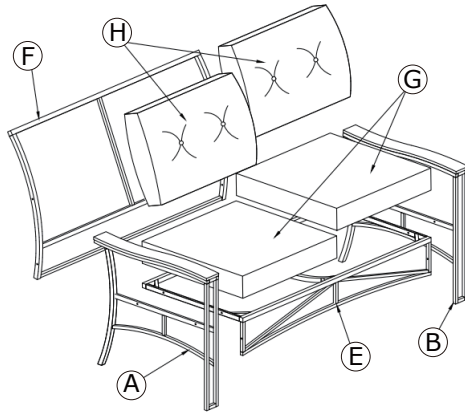
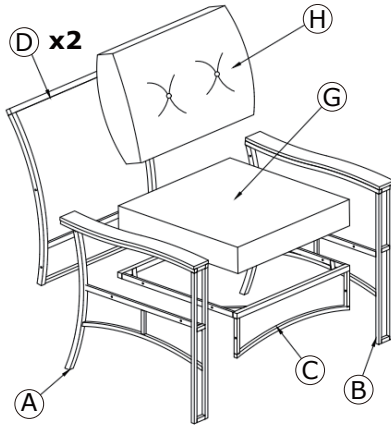

Notice:

1. 50% Tighten before fixing all screws, Allen wrench is recommended instead of an electric drill.
2. Place the item on a flat ground to adjust and make sure it remains stable.
3. Tighten up all screws with tools gradually.
4. If the screws are not aligned with holes during assembly, please loosen all the other screws to 50% and continue the assembly process.
5. If the item is not stable, please loosen all the screws, adjust it on a flat ground and tighten up all screws again.
6. **Note:** If one or some screws are fully tightened during assembly, the others may not be aligned with holes. In addition, all the holes are designed to be relatively larger to provide more space for the adjustment of the screws.

Part & Hardware List



Right frame

(A) x3



Left frame

(B) x3



Seat frame

(C) x2



Back frame

(D) x2

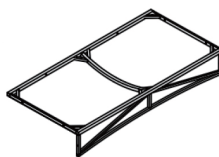

Bench seat frame

(E) x1

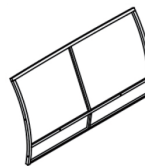

Bench back frame

(F) x1

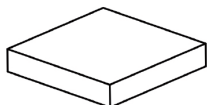

Seat cushion

(G) x4



Back cushion

(H) x4

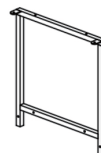

Table leg frame

(I) x2

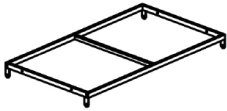
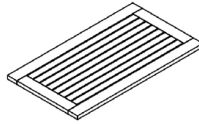

Table bottom frame

ⓐ x1



Wooden table top

ⓑ x1



Bolt
M6x40mm

ⓒ x16



Bolt
M6x35mm

ⓓ x8



Bolt
M6x25mm

ⓔ x16



Bolt
M6x15mm

ⓕ x4



M6x1 Washers

ⓖ x44



Screw
M6x25mm

ⓗ x4



Screw
M6x15mm

ⓘ x4

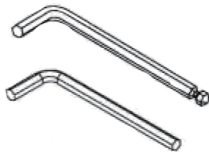

Allen key M4

ⓙ x2

1

(2x Chair assembly)
Connect Back frame (D)
to Seat frame (C) with
Bolt (2) & Washer (5)

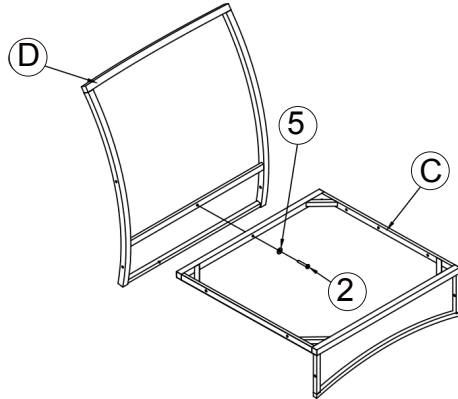

2

Connect part from Step
1 to Right arm (A) with
Bolt (1), Bolt (2), Bolt (3)
& Washers (5)

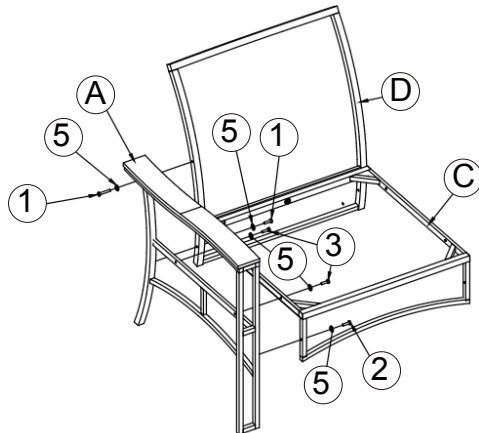

3

Connect part from Step2 to Left arm (B) with Bolt (1), Bolt (2), Bolt (3) & Washers (5)

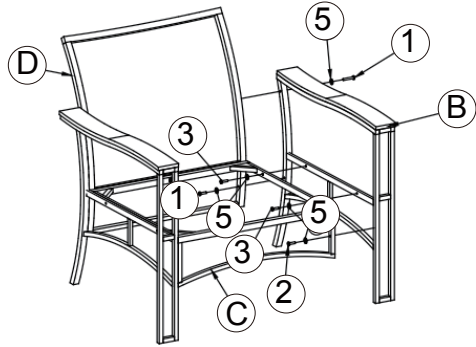

4

Put on Seat cushion (G) and Back cushion (H) to complete single chair

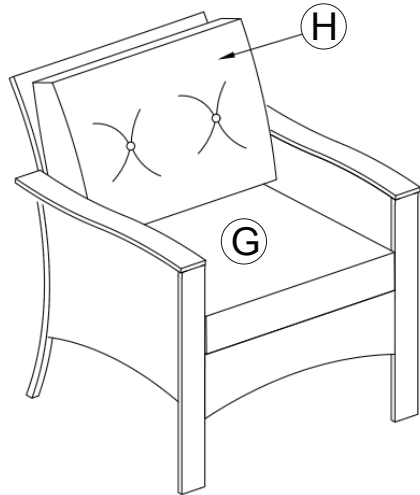

5

(Bench assembly)
Connect Bench back
frame (F) to Bench seat
frame (E) with Bolt (1) &
Washer (5)

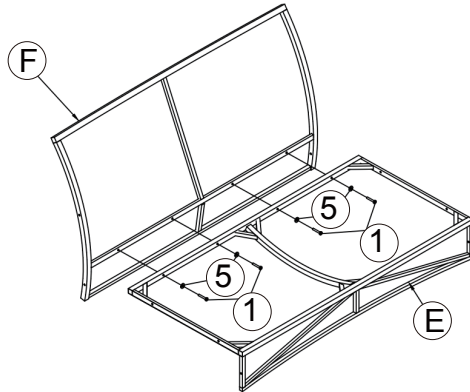

6

Connect part from Step
5 to Right arm (A) with
Bolt (1), Bolt (2), Bolt (3)
& Washers (5)

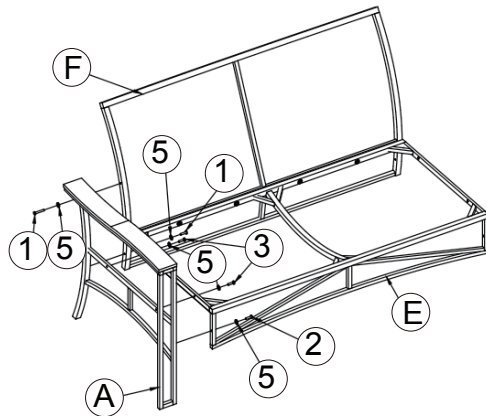

7

Connect part from Step 6 to Left arm (B) with Bolt (1), Bolt (2), Bolt (3) & Washers (5)

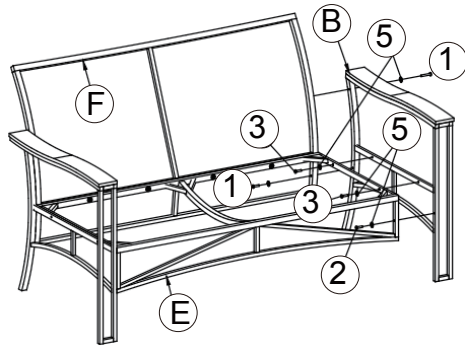

8

Put on Seat cushion (G) and Back cushion (H) to complete bench

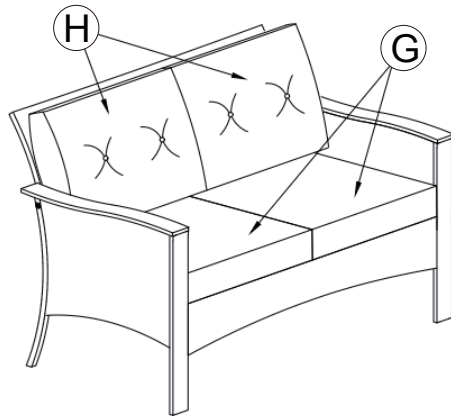

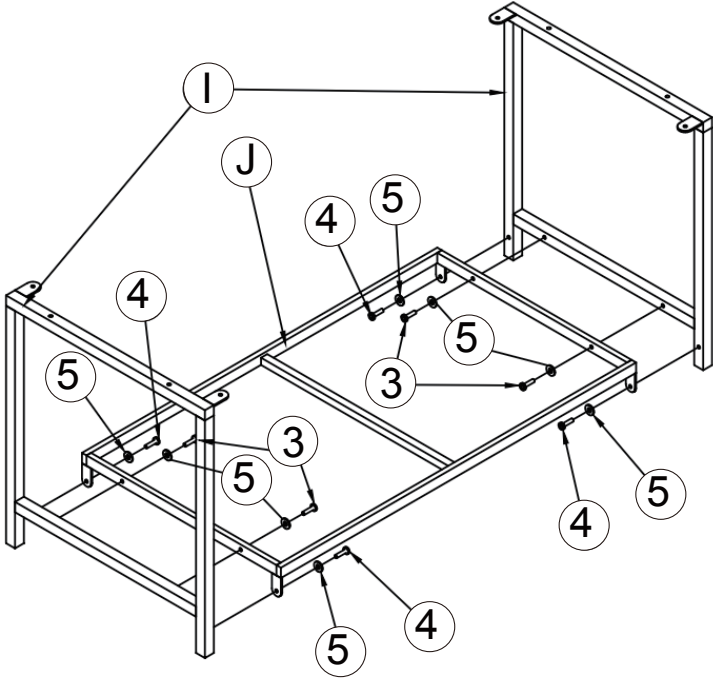

(Table assembly)
Connect table leg frame (I) to Table bottom frame (J) with Bolt (3), Bolt (4) & Washers (5)

10

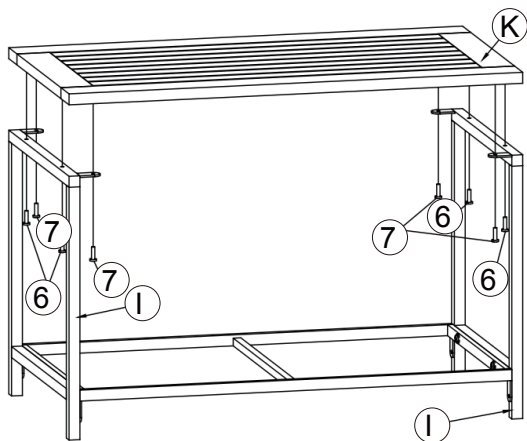

Connect part from step 9 to Wooden table top (K) with Screw (6),
Screw (7)

11

Complete the table

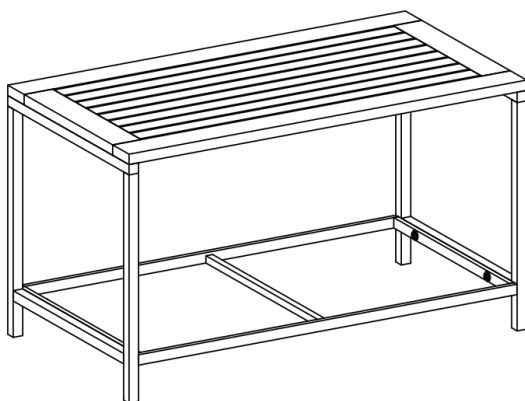

FINISHED

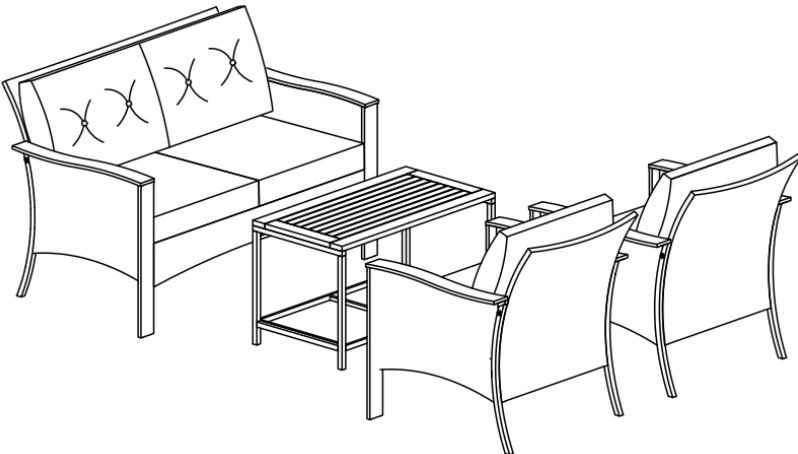



Return / Damage Claim Instructions

- ⚠ **DO NOT discard the box / original packaging.**
In case a return is required, the item must be returned in original box. Without this your return will not be accepted.
- ⚠ **Take a photo of the box markings.**
A photo of the markings (text) on the side of the box is required in case a part is needed for replacement. This helps our staff identify your product number to ensure you receive the correct parts.
- ⚠ **Take a photo of the damaged part (if applicable).**
A photo of the damage is always required to file a claim and get your replacement or refund processed quickly. Please make sure you have the box even if it is damaged.
- ⚠ **Send us an email with the images requested.**
Email us directly from marketplace where your item was purchased with the attached images and a description of your claim.

USA office: Fontana **AUS** office: Truganina

GBR office: FDS Corporation Limited, Unit 4, Blackacre Road, Great Blakenham, Ipswich, Ip6 0FL, United Kingdom

If you're having difficulty, our friendly customer team is always here to help.



USA: cs.us@costway.com
AUS: cs.au@costway.com
GBR: cs.uk@costway.com