

Beside Table / Beistelltisch
Bureau avec Tiroirs / Escritorio con Cajones
Scrivania con Cassetti / Biurko

CB10691

THIS INSTRUCTION BOOKLET CONTAINS **IMPORTANT** SAFETY INFORMATION.
PLEASE READ AND KEEP FOR FUTURE REFERENCE.

EN



Before You Start

- ⚠ Please read all instructions carefully.
- ⚠ Retain instructions for future reference.
- ⚠ Separate and count all parts and hardware.
- ⚠ Read through each step carefully and follow the proper order.
- ⚠ We recommend that, where possible, all items are assembled near to the area in which they will be placed in use, to avoid moving the product unnecessarily once assembled.
- ⚠ Always place the product on a flat, steady and stable surface.
- ⚠ Keep all small parts and packaging materials for this product away from babies and children as they potentially pose a serious choking hazard.

DE



Vor dem Beginnen

- ⚠ Bitte lesen Sie alle Anweisungen sorgfältig durch.
- ⚠ Bewahren Sie die Anweisungen zum zukünftigen Verwendung auf.
- ⚠ Überprüfen Sie, ob alle Teile und Zubehörteile vorhanden sind.
- ⚠ Lesen Sie jeden Schritt sorgfältig durch und befolgen Sie die richtige Reihenfolge.
- ⚠ Wir empfehlen, alle Teile möglichst in der Nähe des Aufstellungsortes zu montieren, um unnötige Bewegungen nach der Montage zu vermeiden.
- ⚠ Stellen Sie den Artikel immer auf eine ebene, feste und stabile Fläche.
- ⚠ Halten Sie alle kleinen Teile und Verpackungsmaterialien fern von Babys und Kindern, ansonsten besteht Erstickungsgefahr.

FR



Avant de Commencer

- ⚠ Veuillez lire attentivement toutes les instructions.
- ⚠ Conservez les instructions pour vous y référer ultérieurement.
- ⚠ Vérifiez toutes les pièces et les accessoires.
- ⚠ Lisez attentivement chaque étape et suivez l'ordre correct.
- ⚠ Nous recommandons que, dans la mesure du possible, tous les produits soient assemblés à proximité de la zone où ils seront utilisés, afin d'éviter tout déplacement inutile du produit une fois assemblé.
- ⚠ Placez toujours le produit sur une surface plane et stable.
- ⚠ Conservez toutes les petites pièces de ce produit et les matériaux d'emballage hors de portée des bébés et des enfants, car ils pourraient présenter un risque d'étouffement.

ES



Antes de Empezar

- ⚠ Lea atentamente todas las instrucciones.
- ⚠ Conserve las instrucciones para futuras consultas.
- ⚠ Separe y cuente todas las piezas y los accesorios.
- ⚠ Lea detenidamente cada paso y siga el orden correcto.
- ⚠ Recomendamos que, siempre que sea posible, todos los elementos se monten cerca de la zona en la que se van a utilizar, para evitar mover el producto innecesariamente una vez montado.
- ⚠ Coloque siempre el producto sobre una superficie plana, estable y firme.
- ⚠ Mantenga todas las piezas pequeñas y los materiales de embalaje de este producto lejos de los bebés y los niños, ya que pueden representar un grave riesgo de asfixia.

IT



Prima di Iniziare

- ⚠ Si prega di leggere attentamente tutte le istruzioni.
- ⚠ Conservare le istruzioni per riferimento futuro.
- ⚠ Separare e contare tutte le parti e gli accessori.
- ⚠ Leggere attentamente ogni passo e seguire l'ordine corretto.
- ⚠ Si consiglia, ove possibile, di assemblare tutti gli articoli vicino alla zona in cui verranno posti in uso, per evitare di spostare inutilmente il prodotto una volta assemblato.
- ⚠ Posizionare sempre il prodotto su una superficie piana, stabile.
- ⚠ Tenere tutte le piccole parti e i materiali di imballaggio di questo prodotto lontano dalla portata di neonati e bambini, in quanto possono costituire un serio pericolo di soffocamento.

PL



Zanim Zaczniez

- ⚠ Zapoznaj się z instrukcją.
- ⚠ Zachowaj instrukcję do wglądu.
- ⚠ Posortuj części i upewnij się, że zestaw jest kompletny.
- ⚠ Zapoznaj się ze sposobem montażu i postępuj zgodnie z instrukcją.
- ⚠ Zalecamy, aby montaż odbywał się możliwie najbliżej miejsca docelowego położenia produktu, aby uniknąć niepotrzebnego przesuwania.
- ⚠ Upewnij się, że produkt znajdzie się na płaskiej i stabilnej powierzchni.
- ⚠ Upewnij się, że materiały wykorzystane podczas pakowania produktu oraz jego elementy znajdują się poza zasięgiem dzieci, gdyż stwarzają potencjalne ryzyko zadławienia.

EN: THIS ITEM IS MADE OF LAMINATED PARTICLE BOARD AND MEDIUM-DENSITY FIBRE BOARD. TO BE ASSEMBLED ON A DRY, SOFT SMOOTH, AND CLEAN SURFACE. DO NOT USE DETERGENT OR CHEMICAL. AVOID DAMP AND SUNLIGHT.

DE: DIESER ARTIKEL IST AUS LAMINIERTEN SPANPLATTEN UND MITTELDICHTEN FASERPLATTEN HERGESTELLT. AUF EINER TROCKENEN, WEICHEN, GLATTEN UND SAUBEREN OBERFLÄCHE MONTIERT WERDEN. KEINE REINIGUNGSMITTEL ODER CHEMIKALIEN VERWENDEN. VERMEIDEN SIE FEUCHTIGKEIT UND SONNENLICHT.

FR: ATTENTION: CET ARTICLE EST FABRIQUÉ À PARTIR DE PANNEAUX DE PARTICULES STRATIFIÉS ET DE PANNEAUX DE FIBRES À DENSITÉ MOYENNE. IL DOIT ÊTRE MONTÉ SUR UNE SURFACE SÈCHE, SOUPLE, LISSE ET PROPRE. NE PAS UTILISER DE DÉTERGENTS OU DE PRODUITS CHIMIQUES. ÉVITER L'HUMIDITÉ ET LA LUMIÈRE DU SOLEIL.

ES: PRECAUCIÓN: ESTE ARTÍCULO ESTÁ FABRICADO CON TABLEROS DE PARTÍCULAS LAMINADAS Y TABLEROS DE FIBRAS DE DENSIDAD MEDIA. DEBE MONTARSE SOBRE UNA SUPERFICIE SECA, SUAVE, LISA Y LIMPIA. NO UTILICE DETERGENTES NI PRODUCTOS QUÍMICOS. EVITE LA HUMEDAD Y LA LUZ SOLAR.

IT: NOTA: QUESTO ARTICOLO È REALIZZATO CON PANNELLI DI PARTICELLE LAMINATE E PANNELLI DI FIBRA A MEDIA DENSITÀ. DA ASSEMBLARE SU UNA SUPERFICIE ASCIUTTA, MORBIDA, LISCIA E PULITA. NON UTILIZZARE DETERGENTI O PRODOTTI CHIMICI. EVITARE L'UMIDITÀ E LA LUCE DEL SOLE.

PL: UWAGA: PRODUKT JEST WYKONANY Z LAMINOWANEJ PŁYTY WIÓROWEJ ORAZ PŁYTY WŁÓKNOWEJ ŚREDNIEJ GĘSTOŚCI I MUSI BYĆ MONTOWANY NA SUCHEJ, MIĘKKIEJ, GŁADKIEJ I CZYSTEJ POWIERZCHNI. NIE UŻYWAJ DETERGENTÓW ANI ŚRODKÓW CHEMICZNYCH. UNIKAJ WILGOCI I BEZPOŚREDNIEGO ŚWIATŁA SŁONECZNEGO.

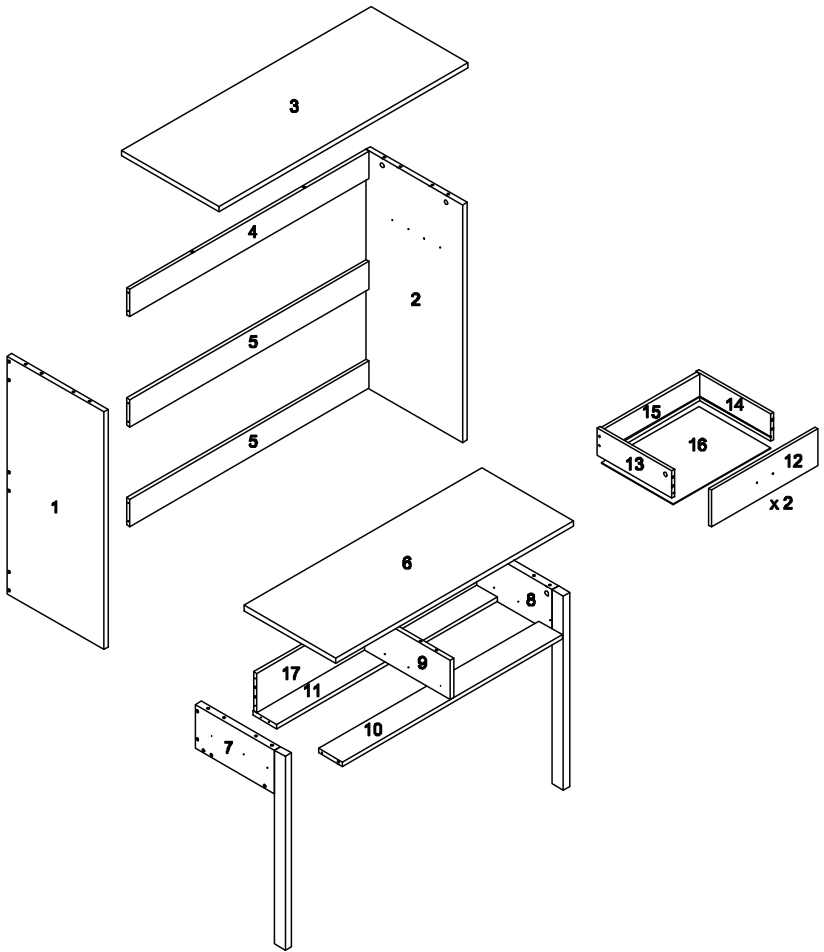

PANEL / PANEL / PANNEAU / PANEL / PANNELLO/ PANEL

① X1

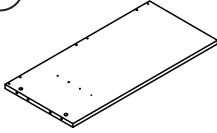

② X1

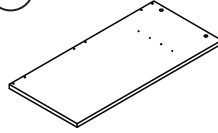

③ X1

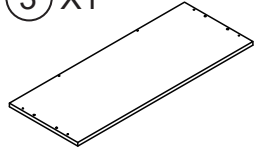

④ X1

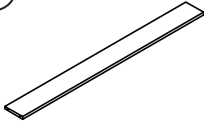

⑤ X2

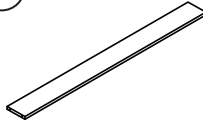

⑥ X1

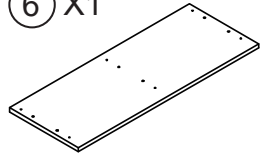

⑦ X1

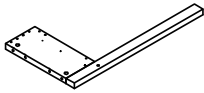

⑧ X1

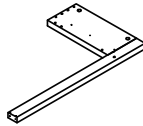

⑨ X1

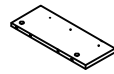

⑩ X1

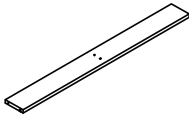

⑪ X1

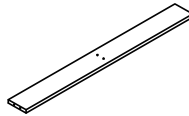

⑫ X2

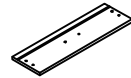

⑬ X2



⑭ X2



⑮ X2





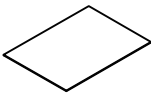



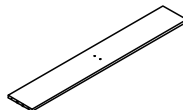









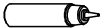

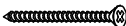



⑯ X2



⑰ X1



















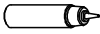

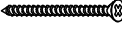
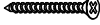

CHECK YOUR HARDWARE

A		SCREW PAN HEAD M3.5 X 12	x5
B		WEBBING	x1
C		WASHER	x2
D		WALL PLUG	x1
E		SCREW #6 X 1 1/4"	x1
F		STICKER	x22
G		GLUE	x1
H		EURO BOLT	x14
I		SCREW #9 X2"	x10
J		SCREW #9 X1 1/2"	x24
K		CAM LOCK D12 X 9.5MM	x4
L		CAM LOCK D15 X 12.5MM	x10
M		WOOD DOWEL M6 X 25	x10
N		WOOD DOWEL M8 X 25	x14
O		LEG STUD	x4
P		ROLLER	x2
Q		HANDLE	x2
R		SCREW PAN HEAD #6 X 20	x4
S		METAL RUNNER	2 SETS
T		BALL BEARING	1 SET
U		SCREW M4 X14	x8
V		SCREW M4 X 12	x30

TOOLS REQUIRED:

	SCREW DRIVER		HAMMER
---	--------------	---	--------























ÜBERPRÜFEN SIE IHRE HARDWARE

A		SCHRAUBEN-SCHWENKKOPF M3,5 X 12	x5
B		GURTBAND	x1
C		UNTERLEGSCHIEBE	x2
D		DÜBEL	x1
E		SCHRAUBE #6 X 1 1/4"	x1
F		AUFKLEBER	x22
G		KLEBSTOFF	x1
H		EURO-BOLZEN	x14
I		SCHRAUBE #9 X 2"	x10
J		SCHRAUBE #9 X 1 1/2"	x24
K		CAM-SCHLOSS D12 X 9,5MM	x4
L		CAM-SCHLOSS D15 X 12,5MM	x10
M		HOLZDÜBEL M6 X 25	x10
N		HOLZDÜBEL M8 X 25	x14
O		BEINSCHRAUBE	x4
P		ROLLEN	x2
Q		HANDGRIFF	x2
R		SCHRAUBEN-SCHWENKKOPF #6 X 20	x4
S		METALL LÄUFER	2 SÄTZE
T		KUGELLAGER	1 SATZ
U		SCHRAUBE M4 X 14	x8
V		SCHRAUBE M4 X 12	x30



BENÖTIGTES WERKZEUG:

	SCHRAUBENZIEHER		HAMMER
---	-----------------	---	--------



VÉRIFICATION DES ACCESSOIRES

A		VIS À TÊTE PLATE M3,5 X 12	x5
B		KIT ANTI-ROUILLE	x1
C		RONDELLE	x2
D		BOUCHON MURAL	x1
E		VIS #6 X 1 1/4"	x1
F		COLLE	x22
G		GLUE	x1
H		VIS EURO	x14
I		VIS #9 X 2"	x10
J		VIS #9 X 1 1/2"	x24
K		VERROU DE CAME D12 X 9,5MM	x4
L		SERRURE À CAME D15 X 12,5MM	x10
M		CHEVILLE EN BOIS M6 X 25	x10
N		CHEVILLE EN BOIS M8 X 25	x14
O		SUPPORT DE JAMBE	x4
P		ROULEAU	x2
Q		POIGNÉE	x2
R		VIS À TÊTE PLATE #6 X 20	x4
S		GLISSIÈRE EN MÉTAL	2 lots
T		ROULEMENT À BILLES	1 lot
U		VIS M4 X 14	x8
V		VIS M4 X 12	x30

OUTILS NÉCESSAIRES:

	TOURNE VIS		MARTEAU
---	------------	---	---------

















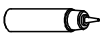

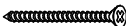



COMPROBAR SUS ACCESORIOS

A		TORNILLO CABEZA PLANA M3,5 X 12	x5
B		KIT ANTIVUELCO	x1
C		ARANDELA	x2
D		ENCHUFE DE PARED	x1
E		TORNILLO #6 X 1 1/4"	x1
F		ADHESIVO	x22
G		PEGAMENTO	x1
H		TORNILLO EURO	x14
I		TORNILLO #9 X 2"	x10
J		TORNILLO #9 X 1 1/2"	x24
K		CERRADURA DE LEVA D12 X 9,5MM	x4
L		CERRADURA DE LEVA D15 X 12,5MM	x10
M		TACO DE MADERA M6 X 25	x10
N		TACO DE MADERA M8 X 25	x14
O		SOPORTE DE PATA	x4
P		RODILLO	x2
Q		MANGO	x2
R		TORNILLO CABEZA PLANA #6 X 20	x4
S		CORREDERA DE METAL	2 juegos
T		RODAMIENTO DE BOLAS	1 juego
U		TORNILLO M4 X 14	x8
V		TORNILLO M4 X 12	x30

HERRAMIENTAS NECESARIAS:

	DESTORNILLADOR		MARTILLO
---	----------------	---	----------

















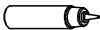





CONTROLLARE GLI ACCESSORI

A		VITE A TESTA CILINDRICA M3,5X 12	x5
B		FOGLIA	x1
C		RONDELLA	x2
D		TAPPO A MURO	x1
E		VITE #6X 1 1/4"	x1
F		ADESIVO	x22
G		COLLA	x1
H		BULLONE EURO	x14
I		VITE #9X 2"	x10
J		VITE #9X1 1/2"	x24
K		BLOCCO A CAMMA D12 X 9,5 MM	x4
L		BLOCCO A CAMMA D15 X 12,5 MM	x10
M		TASSELLO PER LEGNO M6 X 25	x10
N		TASSELLO PER LEGNO M8 X 25	x14
O		PERNO DI GAMBA	x4
P		RULLO	x2
Q		MANIGLIA	x2
R		VITE A TESTA CILINDRICA #6 X 20	x4
S		CORRIDOIO METALLICO	x2
T		CUSCINETTO A SFERA	x1
U		VITE M4X 14	x8
V		VITE M4 X 12	x30



STRUMENTI NECESSARI

	VITE A GUADAGNO		MARTELLO
---	-----------------	---	----------

SPRAWDŹ CZĘŚCI PRZED MONTAŻEM

A		WKREŃT M3,5X12	x5
B		PASEK MOCUJĄCY	x1
C		PODKŁADKA	x2
D		KOŁEK ROZPOROWY	x1
E		WKREŃT #6X1 1/4"	x1
F		ZAŚLEPKA	x22
G		KLEJ	x1
H		TRZPIEŃ	x14
I		WKREŃT #9X2"	x10
J		WKREŃT #9X1 1/2"	x24
K		MIMOŚRÓD D12X9,5MM	x4
L		MIMOŚRÓD D15X12,5MM	x10
M		DREWNIANY KOŁEK M6X25	x10
N		DREWNIANY KOŁEK M8X25	x14
O		STOPKA	x4
P		ROLKA PROWADNICY	x2
Q		UCHWYT	x2
R		ŚRUBA #6X20	x4
S		METALOWA PROWADNICA	x2
T		ŁOŻYSKO KULKOWE	x1
U		WKREŃT M4X14	x8
V		WKREŃT M4X12	x30

POTRZEBNE NARZĘDZIA

	ŚRUBOKREŃT		MŁOTEK
---	------------	---	--------

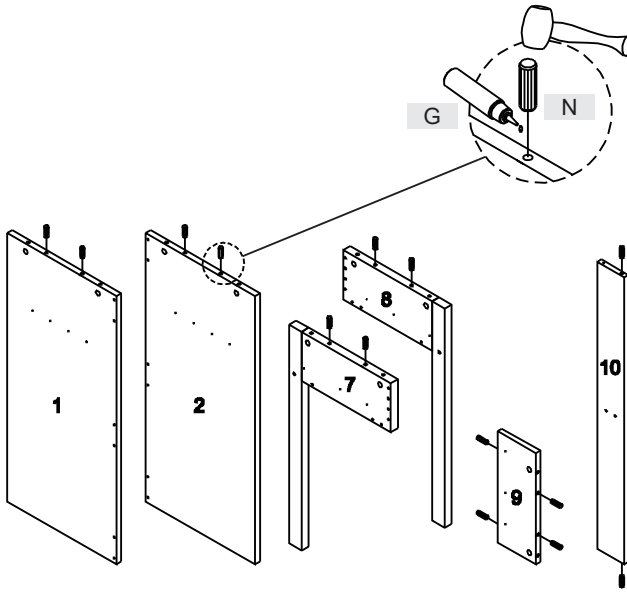
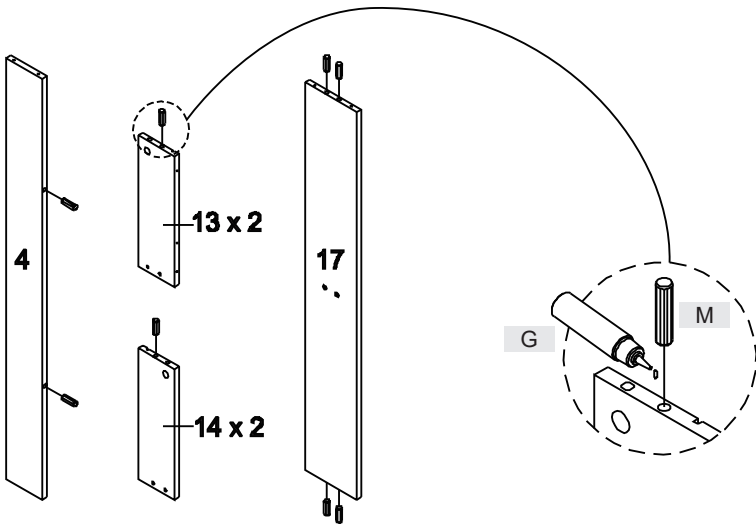
1**2**

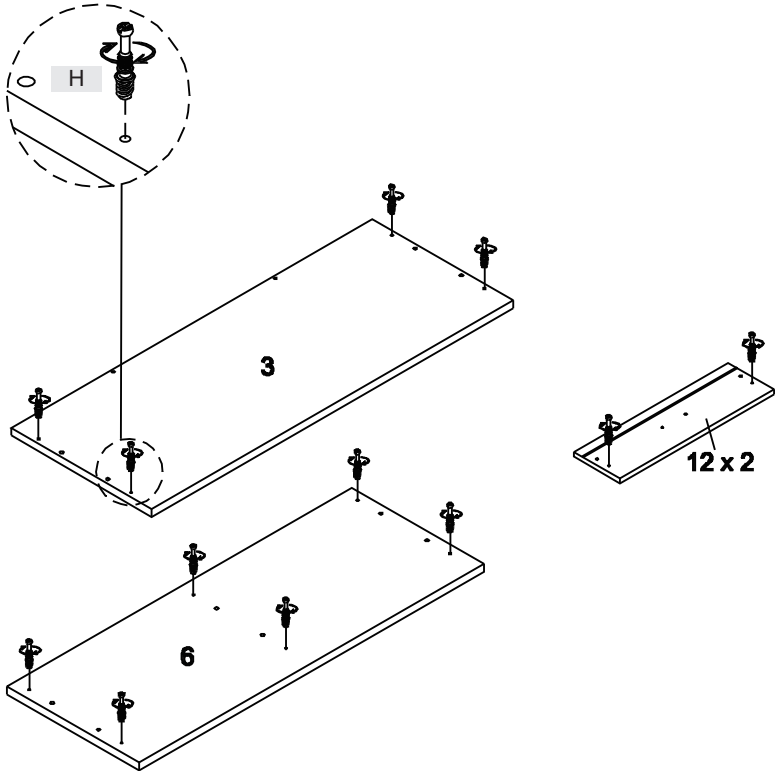

4

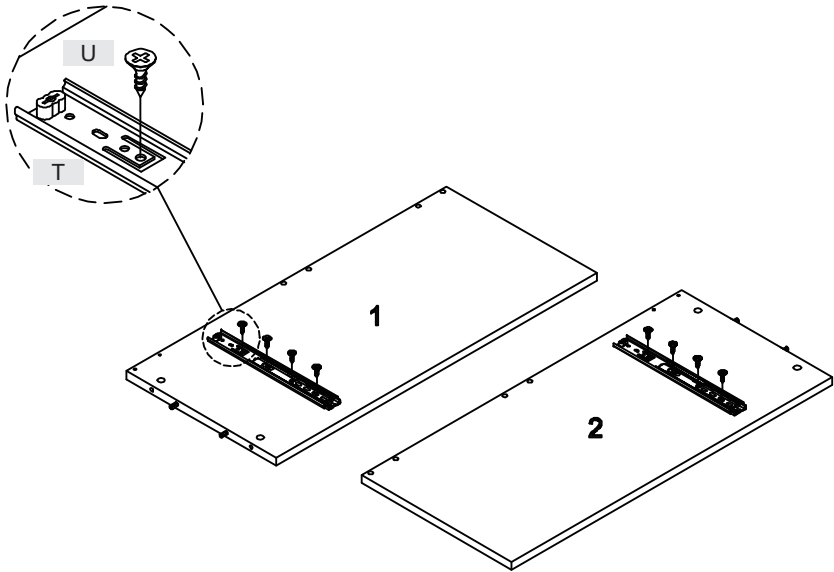
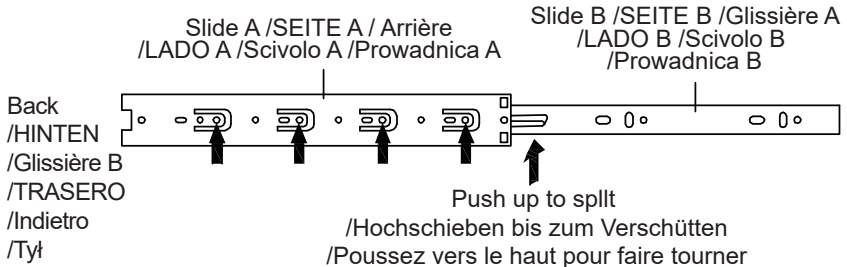

5

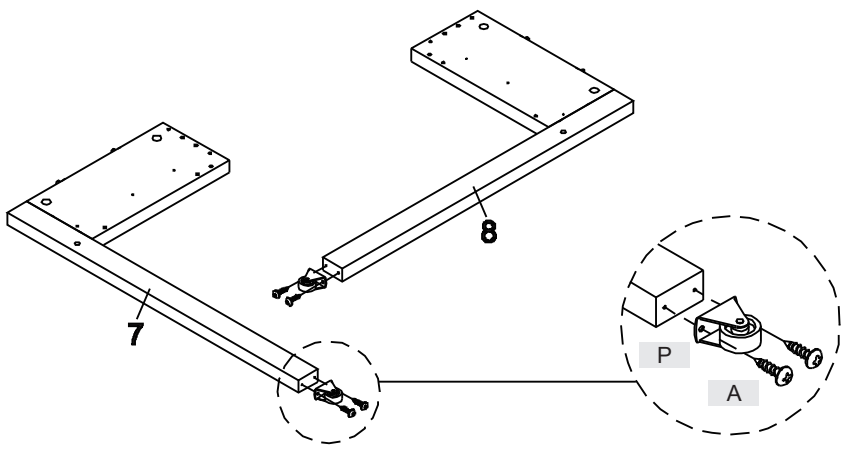

**RIGHT VIEW /RECHTE ANSICHT /VUE DE DROITE
/VISTA DERECHA /VISTA DESTRA /WIDOK OD PRAWEJ STRONY**

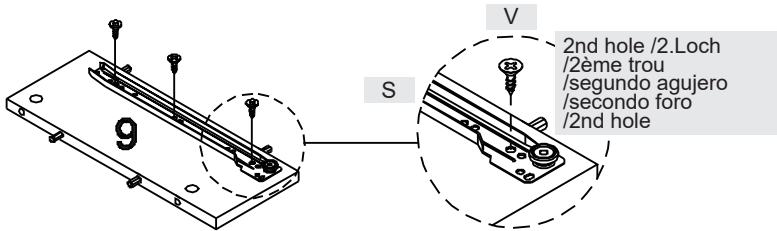

**LEFT VIEW /LINKS ANSICHT / VUE GAUCHE
/VISTA IZQUIERDA /VISTA SINISTRA /WIDOK OD LEWEJ STRONY**

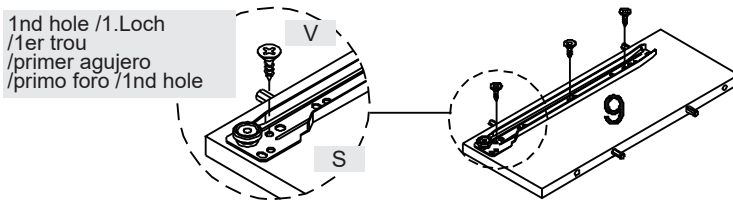

**INNER VIEW /INNERE ANSICHT
/VUE INTÉRIEURE /VISTA
INTERIOR /VISTA INTERNA
/WIDOK OD WEWNĄTRZ**

**INNER VIEW /INNERE ANSICHT
/VUE INTÉRIEURE /VISTA
INTERIOR /VISTA INTERNA
/WIDOK OD WEWNĄTRZ**

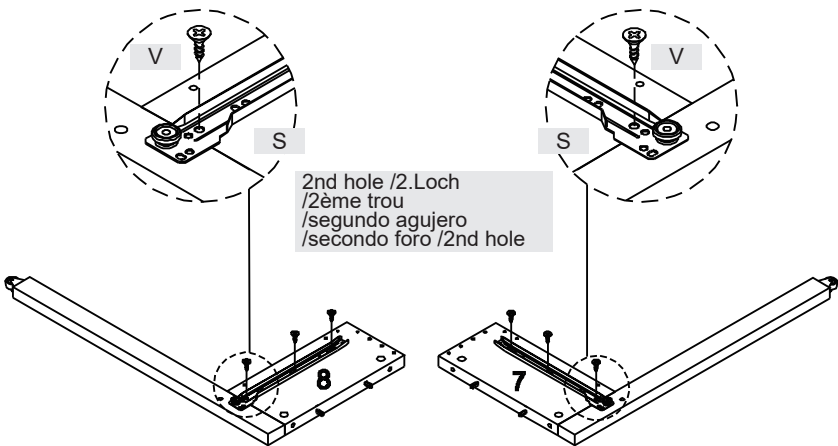

7

**OUTER VIEW /ÄUSSERE ANSICHT
/VUE EXTÉRIEURE /VISTA EXTERIOR
/VISTA ESTERNA /WIDOK OD
ZEWNAŹRZ**

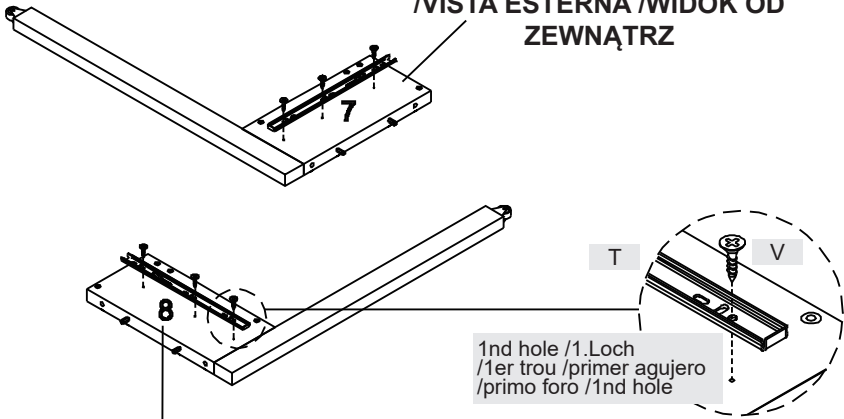

**OUTER VIEW /ÄUSSERE ANSICHT /VUE
EXTÉRIEURE /VISTA EXTERIOR /VISTA
ESTERNA / WIDOK OD ZEWNAŹRZ**

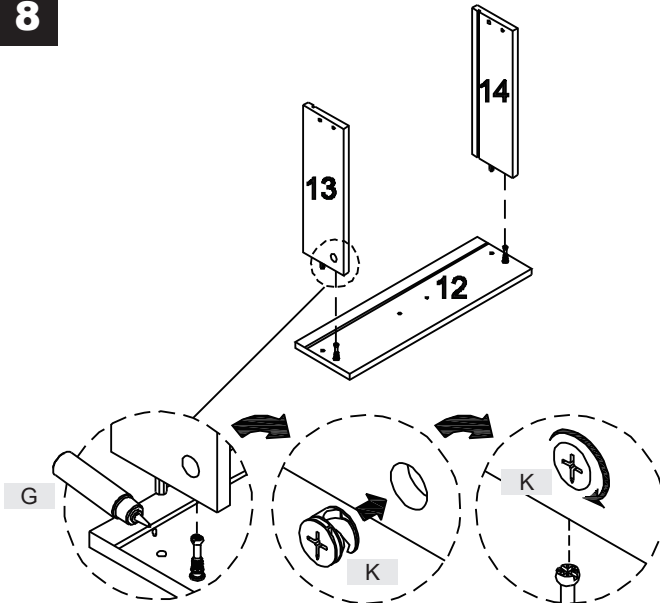
8**X2**

**TURN TO LOCK /DREHEN ZUM SCHLOSS /TOURNER POUR
VERROUILLER /GIRAR PARA BLOQUEAR/RUOTARE PER
BLOCCARE /DOKRĘĆ, ABY ZABLOKOWAĆ**

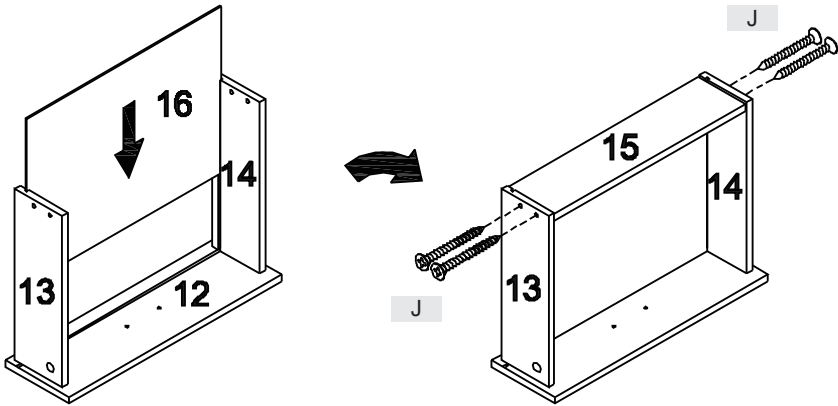
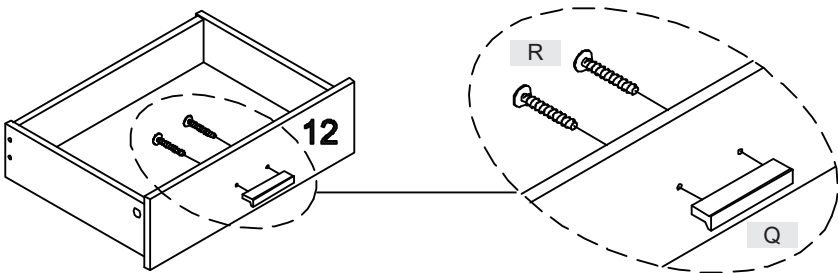
9**X2****10****X2**

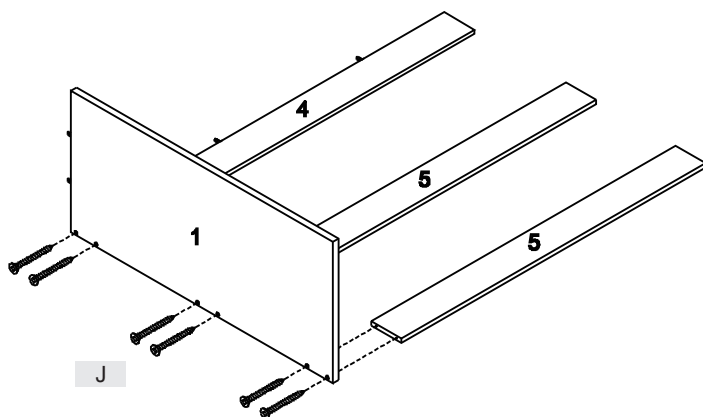
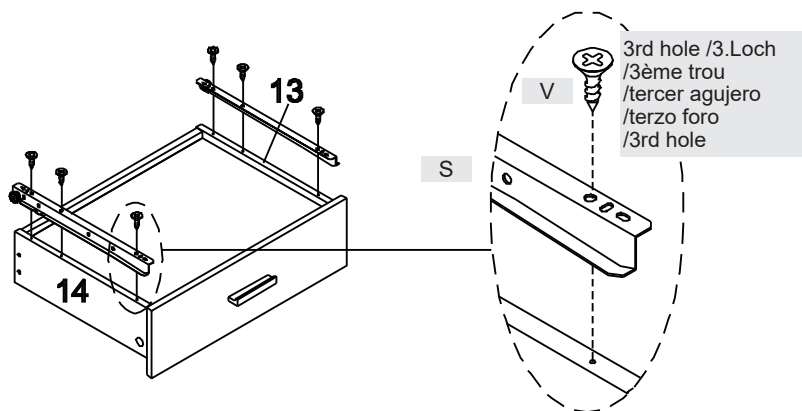

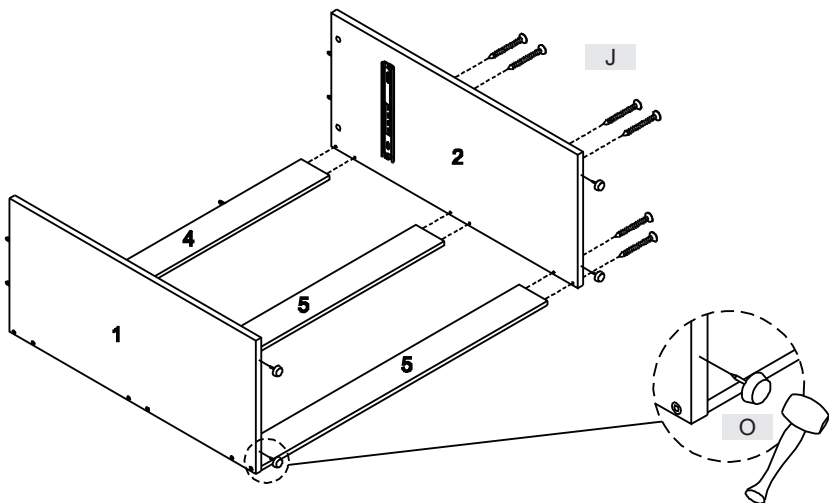

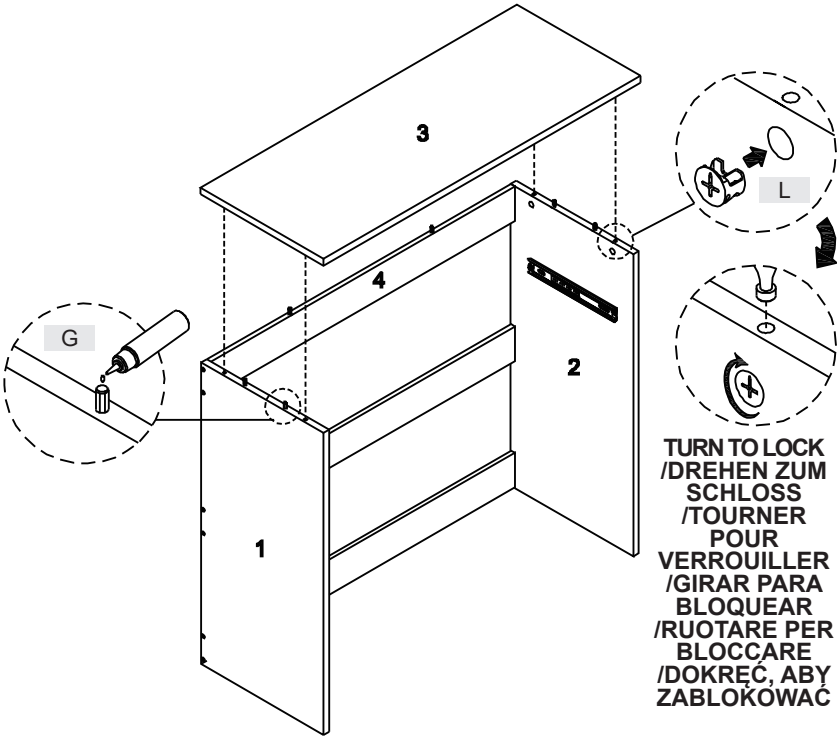

15

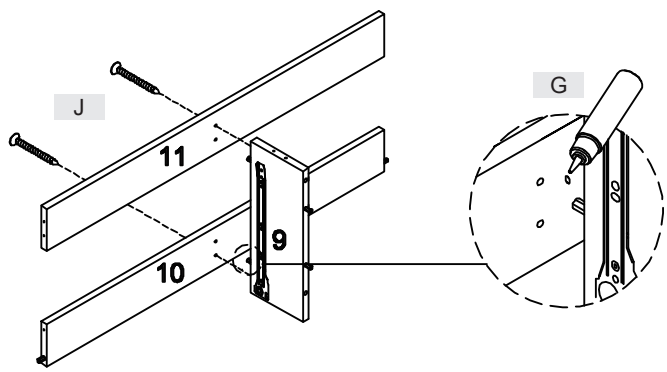

16

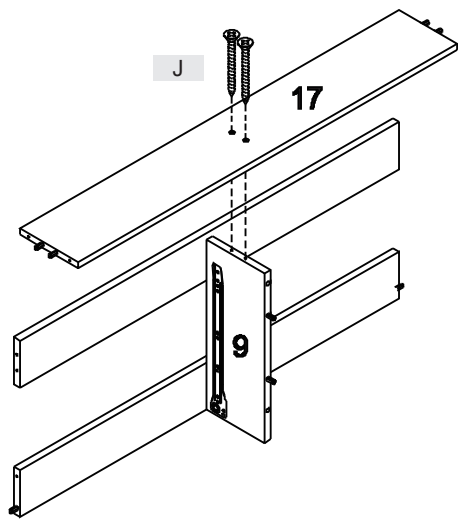

17

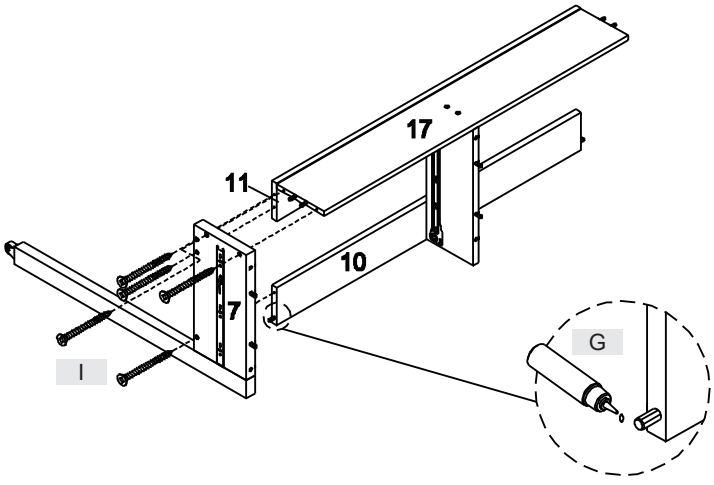

18

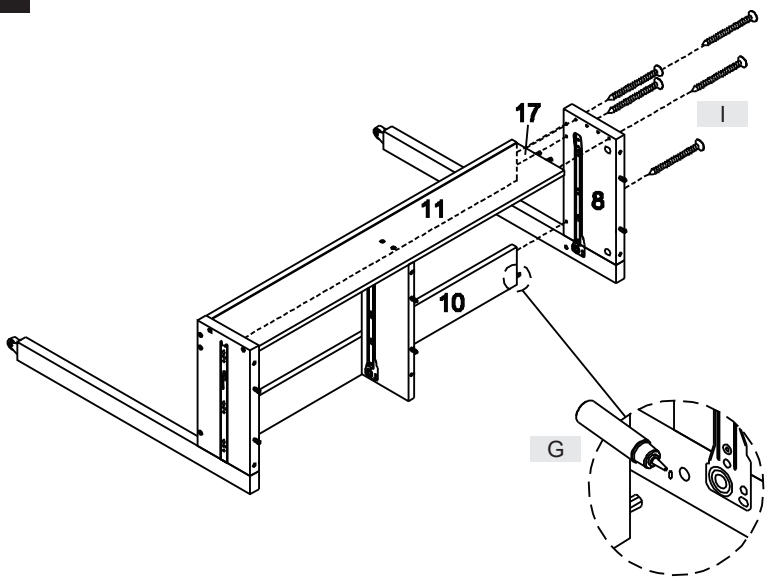

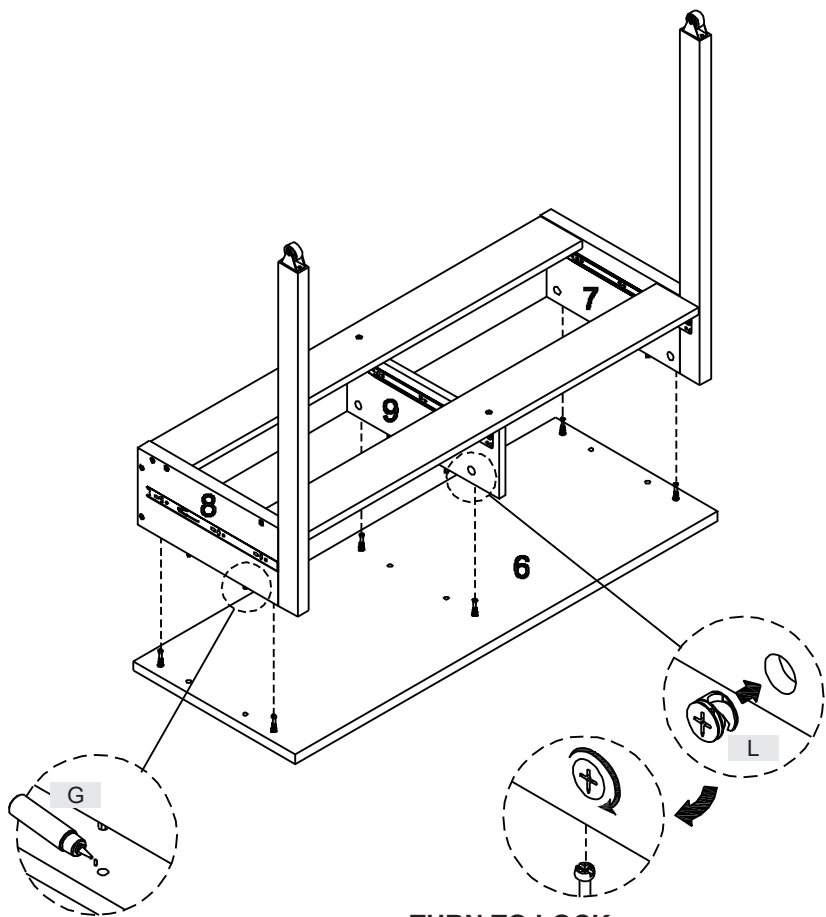

TURN TO LOCK
/DREHEN ZUM SCHLOSS
/TOURNER POUR VERROUILLER
/GIRAR PARA BLOQUEAR
/RUOTARE PER BLOCCARE
/DOKRĘĆ, ABY ZABLOKOWAĆ

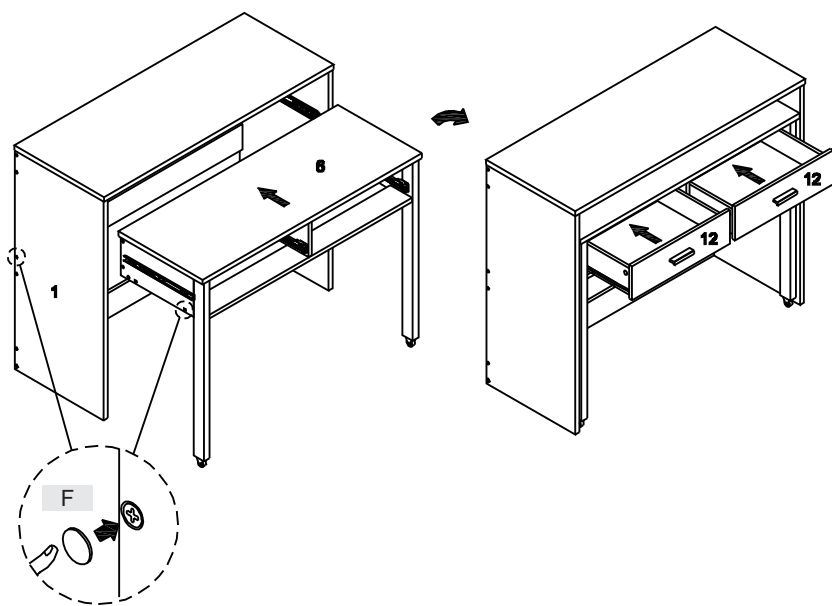

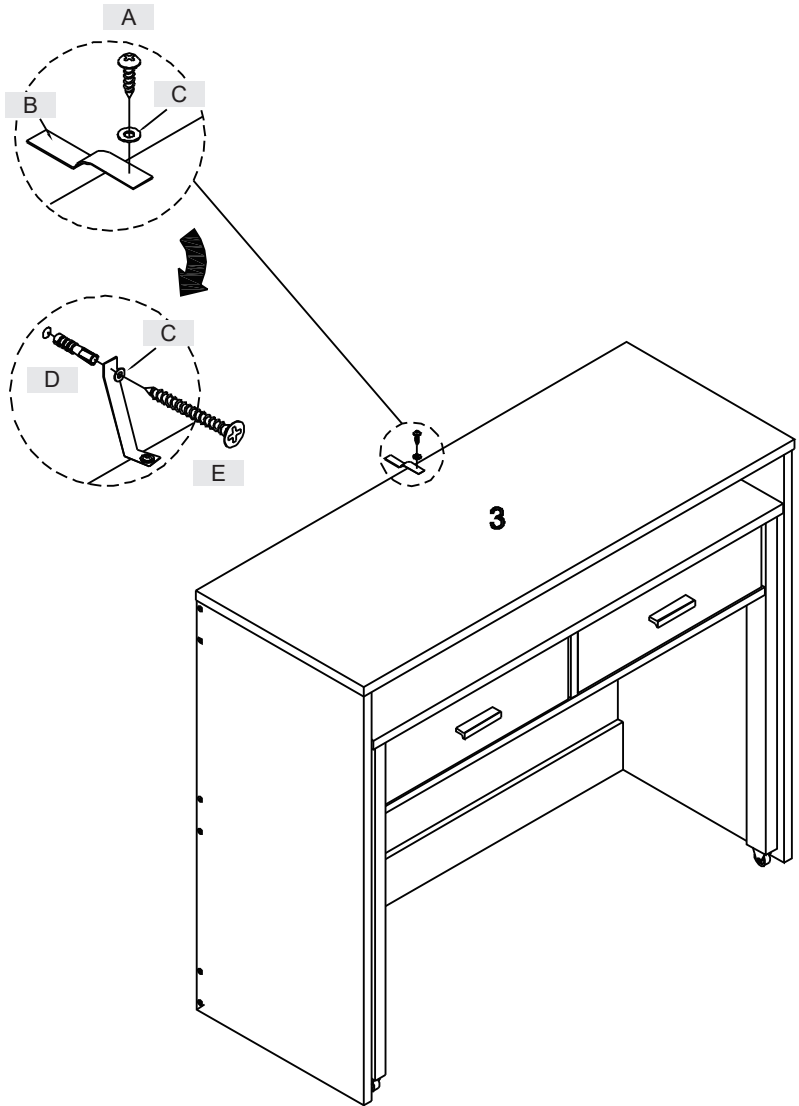





EN





Return / Damage Claim Instructions

-  **DO NOT discard the box / original packaging.**
In case a return is required, the item must be returned in original box. Without this your return will not be accepted.
-  **Take a photo of the box markings.**
A photo of the markings (text) on the side of the box is required in case a part is needed for replacement. This helps our staff identify your product number to ensure you receive the correct parts.
-  **Take a photo of the damaged part (if applicable).**
A photo of the damage is always required to file a claim and get your replacement or refund processed quickly. Please make sure you have the box even if it is damaged.
-  **Send us an email with the images requested.**
Email us directly from marketplace where your item was purchased with the attached images and a description of your claim.

DE



Rücksendung / Beschädigung Anweisungen

-  **Werfen Sie den Karton / die Originalverpackung NICHT weg.**
Falls eine Rücksendung erforderlich ist, muss der Artikel in der Originalverpackung zurückgeschickt werden. Andernfalls wird Ihre Rücksendung nicht angenommen.
-  **Machen Sie ein Foto von der Beschriftung des Kartons.**
Für den Fall, dass ein Ersatzteil benötigt wird, benötigen wir ein Foto der Beschriftung (Text) auf der Seite des Kartons. So können unsere Mitarbeiter Ihre Artikelnummer identifizieren und sicherstellen, dass Sie die richtigen Teile erhalten.
-  **Machen Sie ein Foto des beschädigten Teils (falls zutreffend).**
Ein Foto des beschädigten Teils ist immer erforderlich, um eine Reklamation einzureichen und eine schnelle Bearbeitung Ihres Ersatzteils oder Ihrer Rückerstattung zu gewährleisten. Bitte stellen Sie sicher, dass Sie den Karton haben, auch wenn er beschädigt ist.
-  **Schicken Sie uns eine E-Mail mit dem gewünschten Foto.**
Schicken Sie uns eine E-Mail direkt vom Marktplatz, auf dem Sie den Artikel gekauft haben, mit den angehängten Fotos und einer Beschreibung Ihrer Reklamation.

FR



Instructions De Retour / Réclamation De Dommages

- ⚠ **NE PAS jeter la boîte/l'emballage d'origine.**
Dans le cas où un retour est requis, l'article doit être retourné dans sa boîte d'origine. Sans cela, votre retour ne sera pas accepté.
- ⚠ **Prenez une photo des marquages de la boîte.**
Une photo des marquages (texte) sur le côté de la boîte est requise au cas où une pièce serait nécessaire pour le remplacement. Cela aide notre personnel à identifier votre numéro de produit pour s'assurer que vous recevez les bonnes pièces.
- ⚠ **Prenez une photo des dommages (le cas échéant).**
Une photo des dommages est toujours requise pour déposer une réclamation et obtenir rapidement votre remplacement ou votre remboursement. Assurez-vous d'avoir la boîte même si elle est endommagée.
- ⚠ **Envoyez-nous un e-mail avec les images demandées.**
Envoyez-nous un e-mail directement depuis le marché où votre article a été acheté avec les images ci-jointes et une description de votre réclamation.

ES







Instrucciones de Devolución / Reclamación de Daños

- ⚠ **NO deseche la caja/embalaje original.**
En caso de que se requiera una devolución, el artículo debe ser devuelto en la caja original. Sin esto su devolución no será aceptada.
- ⚠ **Tome una foto de las marcas de la caja.**
Se requiere una foto de las marcas (texto) en el lado de la caja en caso de que se necesite una pieza para reemplazarla. Esto ayuda a nuestro personal a identificar su número de producto para asegurarse de que recibe las piezas correctas.
- ⚠ **Tome una foto de las piezas dañadas (si procede).**
Una foto de los daños es siempre necesaria para presentar una reclamación y conseguir que su reemplazo o reembolso sea procesado rápidamente. Por favor, asegúrese de tener la caja aunque esté dañada.
- ⚠ **Envíenos un correo electrónico con las imágenes solicitadas.**
Envíenos un correo electrónico directamente desde el mercado donde se compró su artículo con las imágenes adjuntas y una descripción de su reclamación.

IT







Istruzioni Per La Restituzione / Reclamo Per Danni

-  **NON scartare la scatola / confezione originale.**
Nel caso in cui sia richiesto un reso, l'articolo deve essere restituito nella scatola originale. Senza la scatola originale il tuo reso non sarà accettato.
-  **Fare una foto dei contrassegni sulla scatola.**
È necessaria una foto dei contrassegni (testo) sul lato della scatola nel caso in cui la parte debba essere sostituita. Questo aiuta il nostro staff a identificare il numero del tuo prodotto per assicurarti di ricevere le parti corrette.
-  **Fare una foto di Danno (se è applicabile).**
Una foto del danno è sempre necessaria per presentare un reclamo e ottenere rapidamente la sostituzione o il rimborso. Assicurati di avere la scatola anche se è danneggiata.
-  **Inviarci una mail con le immagini richieste.**
Inviarci un'e-mail direttamente dal mercato in cui è stato acquistato il tuo articolo con le immagini allegare e una descrizione del tuo reclamo.

PL



Zwroty i reklamacje

-  **Nie wyrzucaj oryginalnego opakowania.**
Jeśli chcesz zwrócić produkt, musi znajdować się on w oryginalnym opakowaniu. Towar zwrócony w nieoryginalnym opakowaniu nie zostanie przyjęty.
-  **Zrób zdjęcie oznaczeń na opakowaniu.**
Jeśli jakkolwiek część wymaga wymiany, zrób zdjęcie oznaczeń kodu produktu, który znajduje się na opakowaniu. Pozwoli nam to zidentyfikować produkt i dostarczyć ci właściwą część.
-  **Zrób zdjęcie uszkodzonej części (jeśli dotyczy).**
Jeśli chcesz złożyć reklamację, zrób zdjęcie uszkodzonej części. Pozwoli nam to zatwierdzić reklamację i zlecić zwrot środków na twoje konto. Do złożenia reklamacji potrzebne będzie oryginalne opakowanie.
-  **Skontaktuj się z nami.**
Skontaktuj się z nami telefonicznie, mailowo lub poprzez formularz kontaktowy. Załącz zdjęcia produktu i opis roszczenia.

USA office: Fontana

AUS office: Truganina

ITA office: Milano

POL office: Gdańsk

DEU office: FDS GmbH, Neuer Höltigbaum 36, 22143 Hamburg, Deutschland

FRA office: Saint Vigor d'Ymonville

GBR office: FDS Corporation Limited, Unit 4, Blackacre Road, Great Blakenham, Ipswich, Ip6 0FL, United Kingdom

If you're having difficulty, our friendly customer team is always here to help.



USA:cs.us@costway.com

AUS:cs.au@costway.com

GBR:cs.uk@costway.com

ITA:cs.it@costway.com

POL:sklep@costway.com

DEU:cs.de@costway.com

FRA:cs.fr@costway.com

ESP:cs.es@costway.com