

Daybed with Trundle

**HV10583**

THIS INSTRUCTION BOOKLET CONTAINS **IMPORTANT** SAFETY INFORMATION.  
PLEASE READ AND KEEP FOR FUTURE REFERENCE.



## Before You Start

- ⚠ Please read all instructions carefully.
- ⚠ Retain instructions for future reference.
- ⚠ Separate and count all parts and hardware.
- ⚠ Read through each step carefully and follow the proper order.
- ⚠ We recommend that, where possible, all items are assembled near to the area in which they will be placed in use, to avoid moving the product unnecessarily once assembled.
- ⚠ Always place the product on a flat, steady and stable surface.
- ⚠ Keep all small parts and packaging materials for this product away from babies and children as they potentially pose a serious choking hazard.

# PARTS LIST

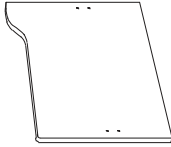

Headboard

(A) x1

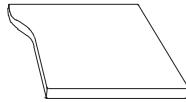

Footboard

(B) x1



Foot

(J) x4



Bed Rail

(C) x2

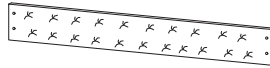

Backboard

(D) x1

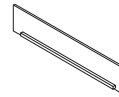

Front panel of under bed

(F) x1

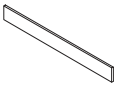

Back panel of under bed

(G) x1



Bed Slats

(E) x1



Slats of under bed with wood block

(H) x1

## Hardware List / Liste des Accessoires

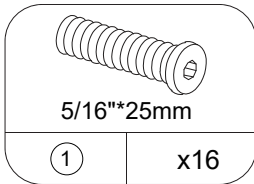

Hang Bolt

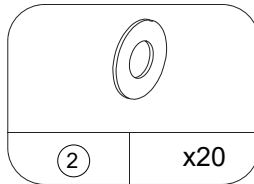

Flat Washer

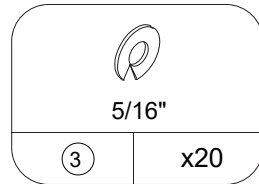

Spring Washer

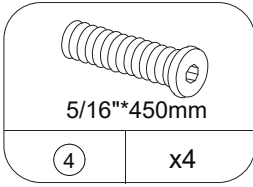

Bolt

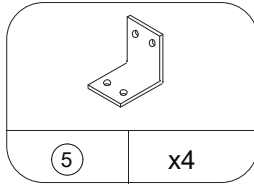

L Metal Connector

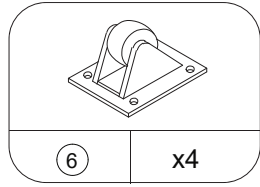

Wheel

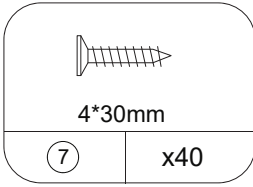

Wood Screw

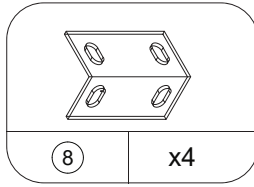

L Metal Connector

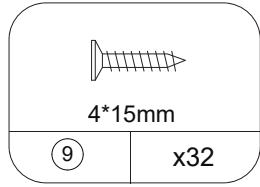

Wood Screw

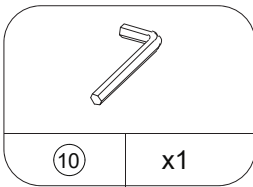

Allen Wrench

ASSEMBLY TOOLS REQUIRED (NOT INCLUDED)

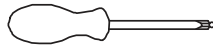

PLEASE BE CAREFUL DO NOT DAMAGE THE HOLE POSITION WHEN YOU USE POWER TOOLS!

# Detail View

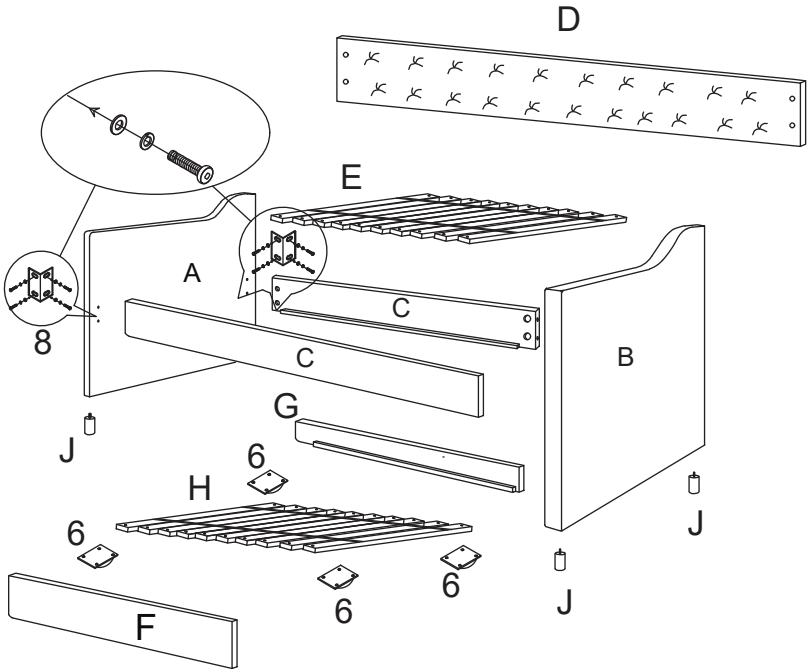

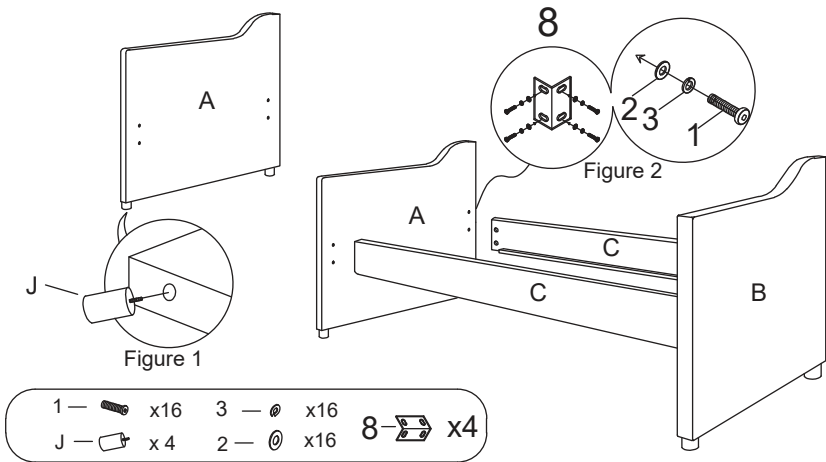

1. Screw four feet into the bottom of Headboard (A) and Footboard (B), as shown in Figure 1.
2. Screw Hang Bolts (1) into Headboard (A) and Bed Rail (C) through L Metal Connector (8) as shown in Figure 2.
3. Repeat the steps 2 for Footboard (B).

## 2

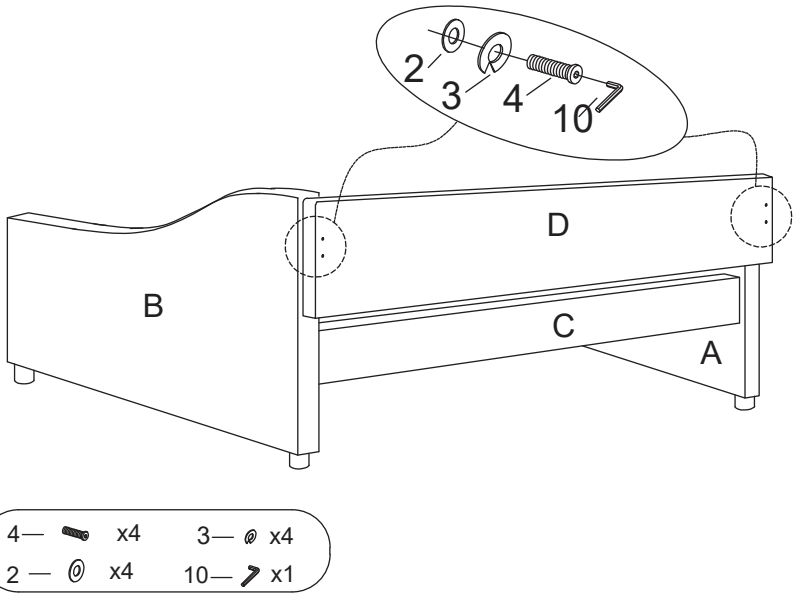

1. Attach Backboard (D) to Headboard (A) and Footboard (B) by using 4 pieces of Bolts (4), 4 pieces of Flat Washer (2), and 4 pieces of Spring Washers (3) as shown in the picture.
2. Use Allen Wrench (10) to tighten all Bolts (4) clockwise as shown.

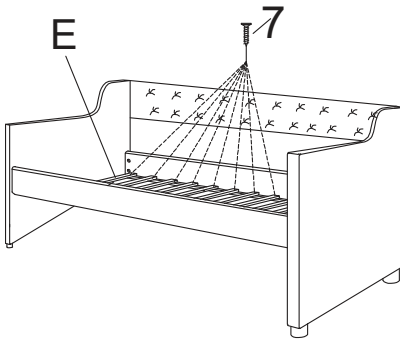

7 —  x20

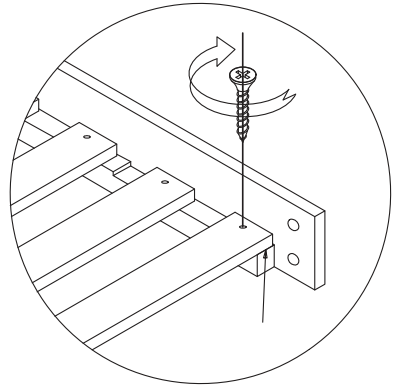
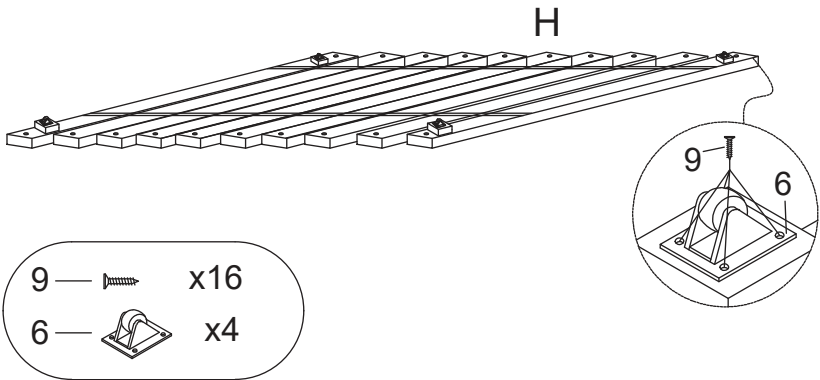
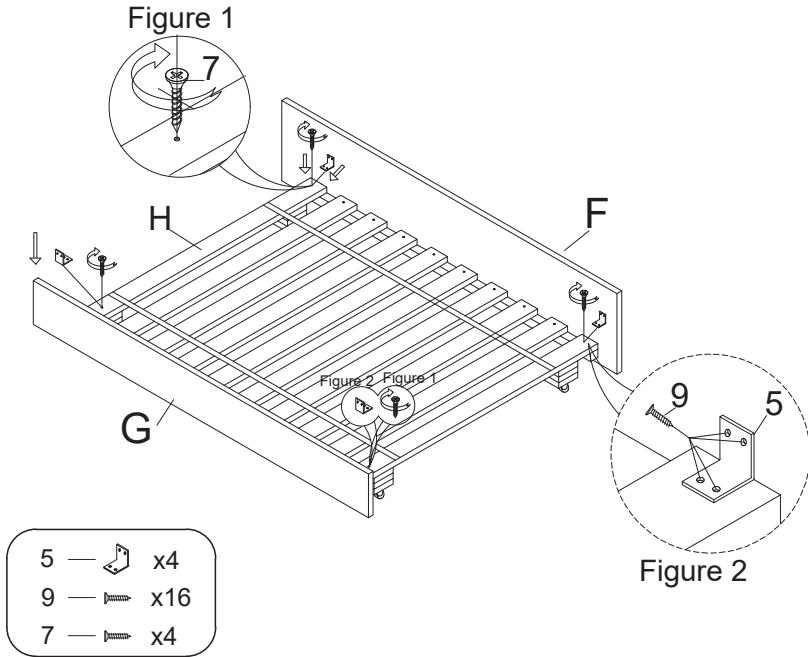

Figure 1  
Flush

1. Put 10 pieces of Bed Slats (E) on the Bed Rails (C).
2. Install Slat Pack with slats starting and ending flush with the end of the support cleat attached to your bed rails in Figure 1.
3. Using Screwdriver to tighten 20 Pieces of Wood Screws (7) clockwise as shown.



1. Attach 4 pieces of Wheels (6) to the Slats of under bed (H) with 16 pieces of Wood Screws (9) as shown in the picture.
2. Use Screwdriver to tighten Wood Screws (9) clockwise as shown in the picture.



1. Use Screwdriver to tighten 4 pieces of Wood Screws (7) to slats of under bed (H) as Figure 1.
2. Attach both outside 2 pieces Slats of under bed (H) to Front panel of under bed (F) and Back panel of under bed (G) by 4 pieces of L metal connector (5), as Figure 2.
3. Use Screwdriver to tighten 16 pieces of Wood Screws (9), as shown.

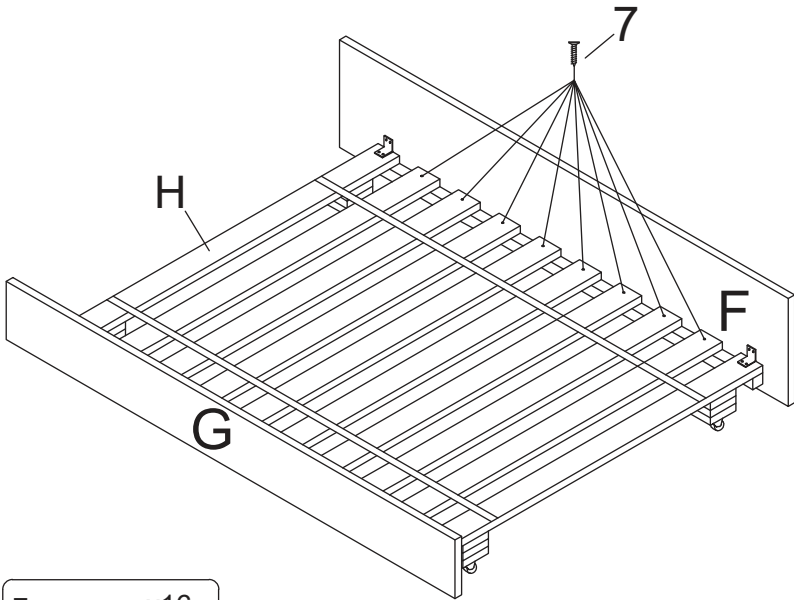

7 —  x16

1. Put Slats of under bed (H) between the Bed Box of Headboard and Bed Box of Headboard as shown.
2. Using Screwdriver to tighten 16 Pieces of Wood Screws (7) clockwise as shown.

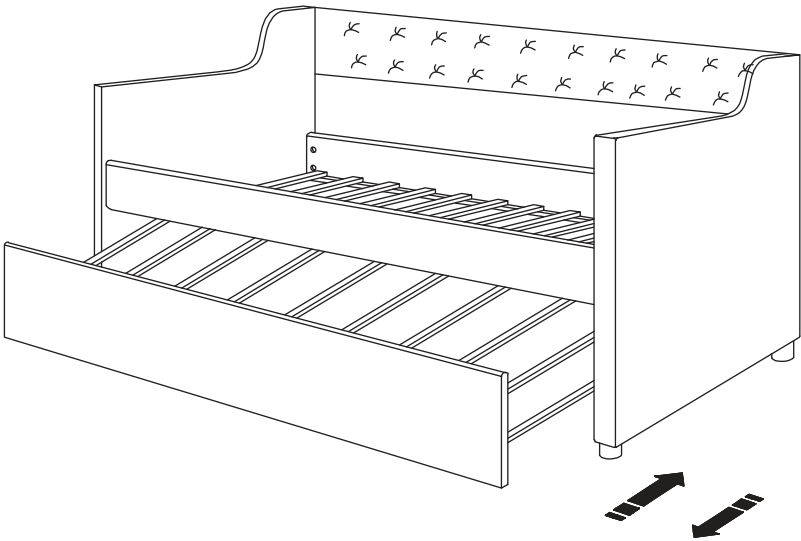

Push the trundle into the Daybed.



## Return / Damage Claim Instructions

- ⚠ DO NOT discard the box / original packaging.**  
In case a return is required, the item must be returned in original box. Without this your return will not be accepted.
- ⚠ Take a photo of the box markings.**  
A photo of the markings (text) on the side of the box is required in case a part is needed for replacement. This helps our staff identify your product number to ensure you receive the correct parts.
- ⚠ Take a photo of the damaged part (if applicable).**  
A photo of the damage is always required to file a claim and get your replacement or refund processed quickly. Please make sure you have the box even if it is damaged.
- ⚠ Send us an email with the images requested.**  
Email us directly from marketplace where your item was purchased with the attached images and a description of your claim.

**USA** office: Fontana

**AUS** office: Truganina

**GBR** office: FDS Corporation Limited, Unit 4, Blackacre Road, Great Blakenham, Ipswich, Ip6 0FL, United Kingdom

---

If you're having difficulty, our friendly customer team is always here to help.



USA: [cs.us@costway.com](mailto:cs.us@costway.com)

AUS: [cs.au@costway.com](mailto:cs.au@costway.com)

GBR: [cs.uk@costway.com](mailto:cs.uk@costway.com)