

3PCS Patio Rattan Furniture Set
HW71539

THIS INSTRUCTION BOOKLET CONTAINS **IMPORTANT** SAFETY INFORMATION.
PLEASE READ AND KEEP FOR FUTURE REFERENCE.



Before You Start

- ⚠ Please read all instructions carefully.
- ⚠ Retain instructions for future reference.
- ⚠ Separate and count all parts and hardware.
- ⚠ Read through each step carefully and follow the proper order.
- ⚠ We recommend that, where possible, all items are assembled near to the area in which they will be placed in use, to avoid moving the product unnecessarily once assembled.
- ⚠ Always place the product on a flat, steady and stable surface.
- ⚠ Keep all small parts and packaging materials for this product away from babies and children as they potentially pose a serious choking hazard.

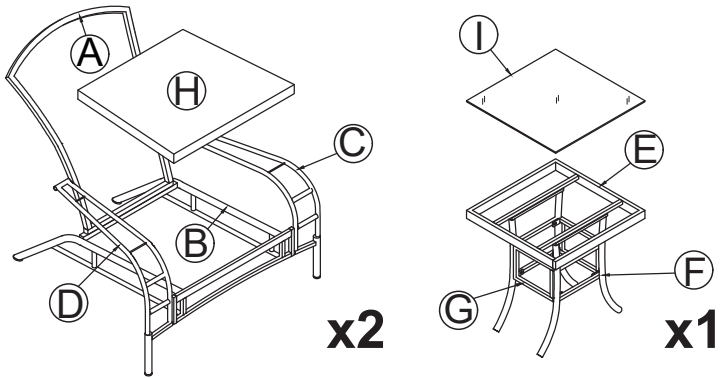

PARTS LIST

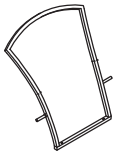

Chair Back

(A) x2

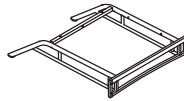

Chair Seat

(B) x2

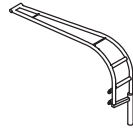

Left Armrest

(C) x2

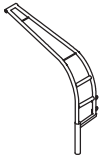

Right Armrest

(D) x2

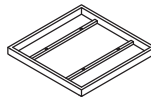

Table Top

(E) x1



Table Leg

(F) x2

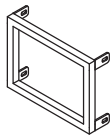
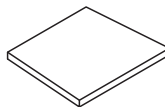

Table Frame

(G) x2



Seat Cushion

(H) x2

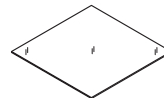

450*450*5mm

Table glass

(I) x1

HARDWARE LIST

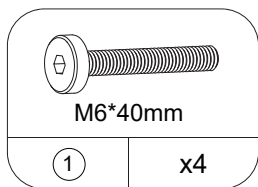

Bolt

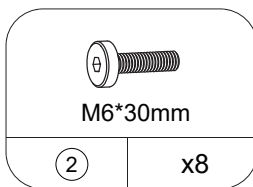

Bolt

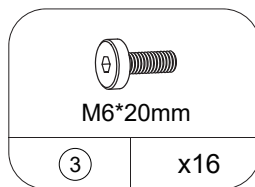

Bolt

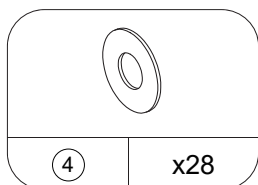

Washer

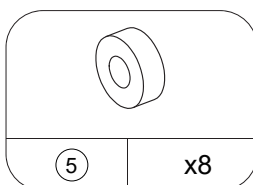

Washer

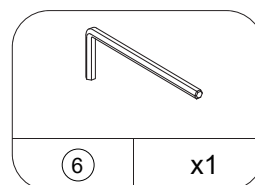

Allen Key

1 x2

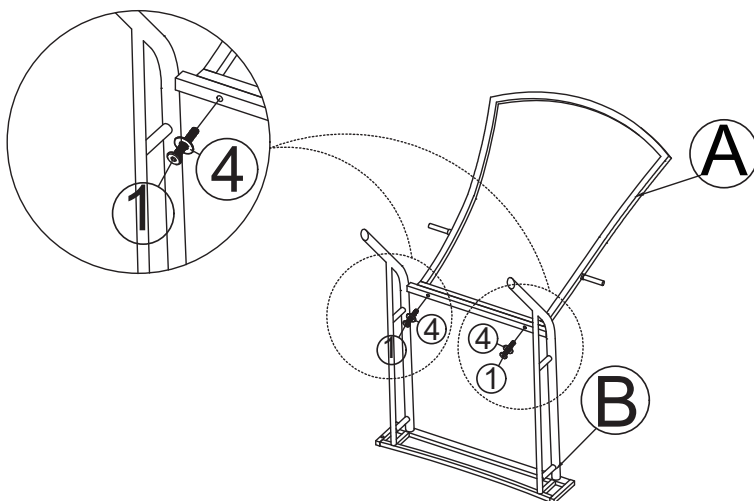
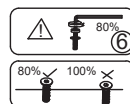

2 x2

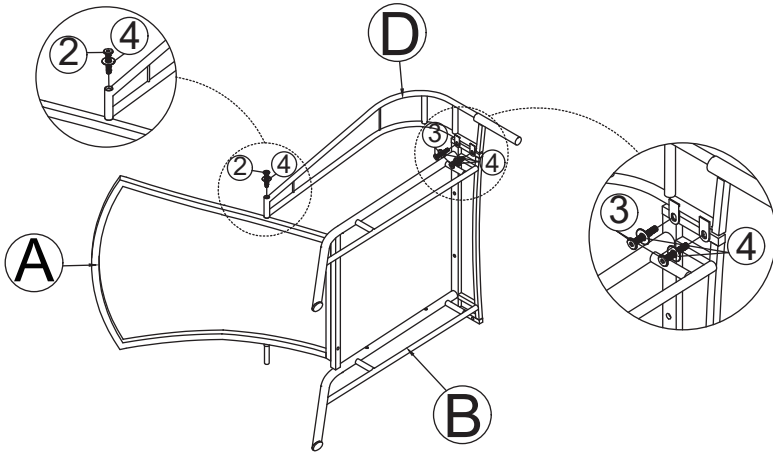
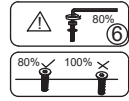

3 x2

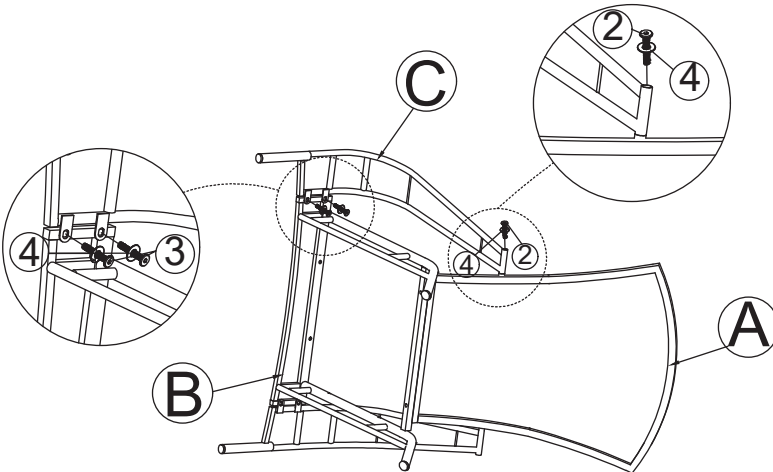
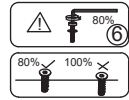

4 x2

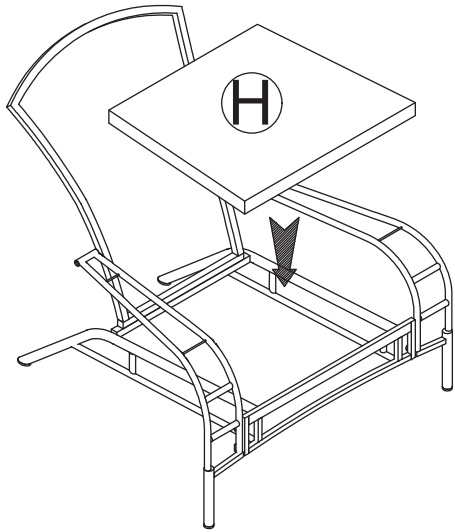

5

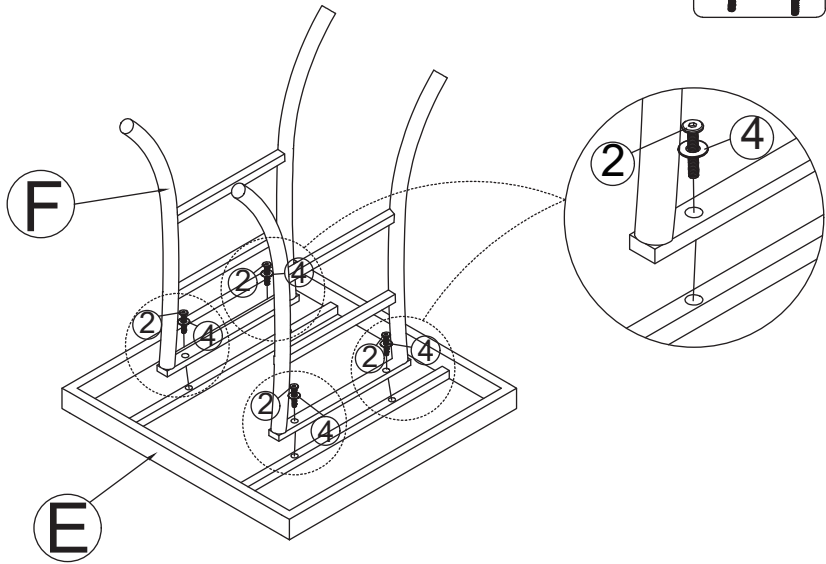
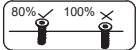

6

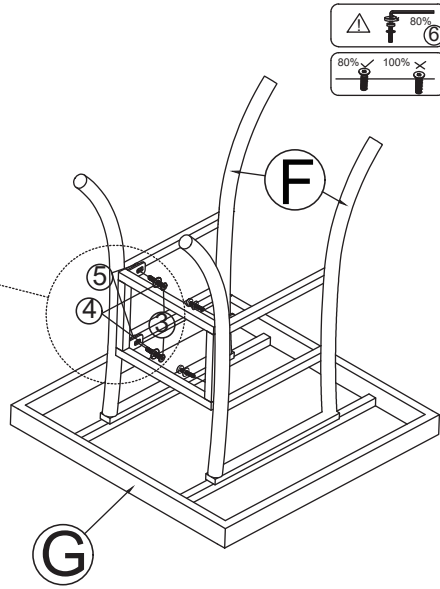
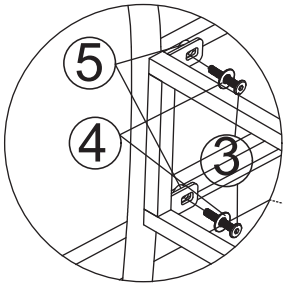

80%

6

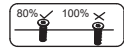

7

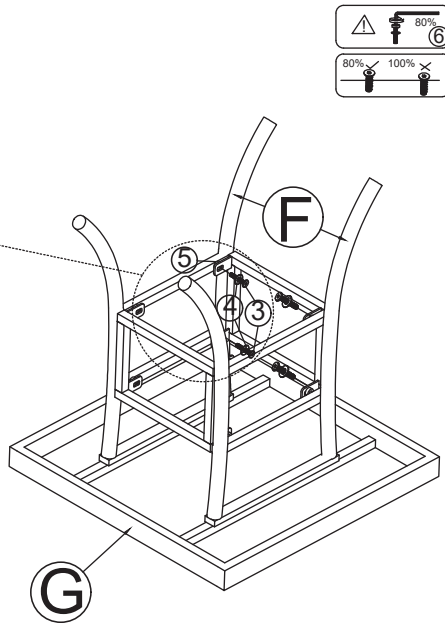
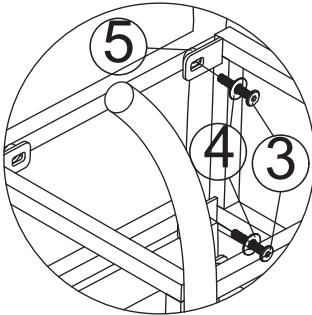

80%

6

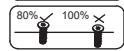

8

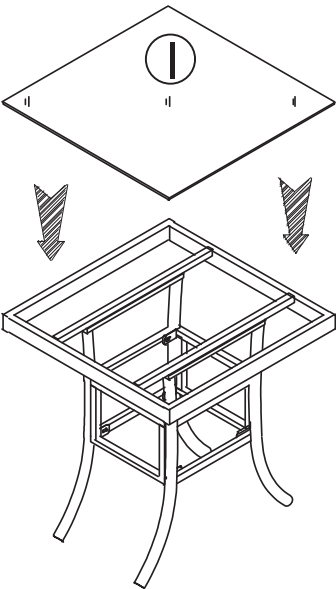

9

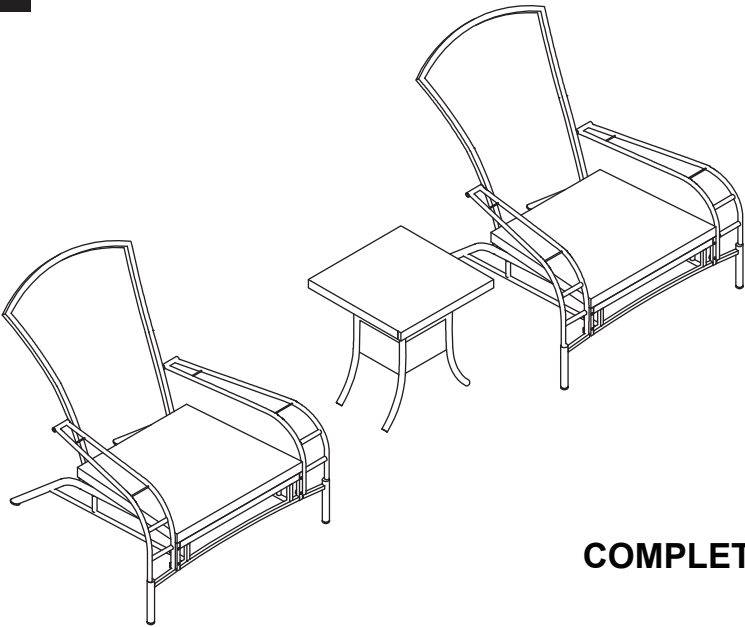

COMPLETE



Return / Damage Claim Instructions

- ⚠ **DO NOT discard the box / original packaging.**
In case a return is required, the item must be returned in original box. Without this your return will not be accepted.
- ⚠ **Take a photo of the box markings.**
A photo of the markings (text) on the side of the box is required in case a part is needed for replacement. This helps our staff identify your product number to ensure you receive the correct parts.
- ⚠ **Take a photo of the damaged part (if applicable).**
A photo of the damage is always required to file a claim and get your replacement or refund processed quickly. Please make sure you have the box even if it is damaged.
- ⚠ **Send us an email with the images requested.**
Email us directly from marketplace where your item was purchased with the attached images and a description of your claim.

USA office: Fontana **AUS** office: Truganina

GBR office: FDS Corporation Limited, Unit 4, Blackacre Road, Great Blakenham, Ipswich, Ip6 0FL, United Kingdom

If you're having difficulty, our friendly customer team is always here to help.



USA: cs.us@costway.com
AUS: cs.au@costway.com
GBR: cs.uk@costway.com